

## ADVANCE OF MARGINAL OSCILLATOR

B. Makarov, V. Ryzhov, Federal State Unitary Enterprise "The Moscow Radio Institute of the Russian Academy of Sciences", Moscow, Russia

### INTRODUCTION

The marginal oscillator is used for detecting nuclear magnetic resonance (NMR) signals. This scheme is convenient for search of resonant absorption of energy by atomic nuclei so it is prevalent in the NMR magnetometers. At present the valve and the transistor oscillators are developed [1 - 5].

In this article is briefly considered the theory of operation and concrete schemes of the marginal on basis of a field-effect transistor (FET).

### BASES OF THEORY

A sample containing nuclear spins is placed in the coil of an oscillatory circuit of the marginal. In this case inductance of the coil is equal

$$L = \mu L_0 = L_0(1 + 4\pi\chi\xi), \quad (1)$$

where  $L_0$  - self inductance of the coil,  $\mu$  - magnetic permeability of substance of the sample,  $\chi$  - dynamic nuclear susceptibility,  $\xi$  - factor of filling of the coil [2].

The impedance of the circuit is changed at the moment of the resonant absorption of the high-frequency energy by spins. The real component of the impedance of the parallel circuit is

$$\frac{\Delta R}{R} = 1 - \frac{1}{(1 + 4\pi\chi' \xi)(1 - 4\pi Q \chi'' \xi)}, \quad (2)$$

and the phase angle is

$$\operatorname{tg} \varphi = - \frac{4\pi Q \chi' \xi}{1 + 4\pi Q \chi'' \xi}. \quad (3)$$

Here  $Q$  is the quality of the oscillatory circuit,  $\chi'$ ,  $\chi''$  are the real and the imaginary parts of dynamic nuclear susceptibility  $\chi = \chi' - j\chi''$ .

The contribution to (2) by real part of the magnetic susceptibility approximately in  $Q$  times is less than the one of its imaginary part. Therefore only as a first approximation it is possible to consider that in the case amplitude detecting the marginal oscillators develop the signal proportional to the absorption. Simultaneously according to (3) the operating frequency is changed. Mainly this change is caused by the imaginary part of the dynamic susceptibility. Thereby the imaginary part of the nuclear susceptibility is responsible for absorption of energy of the radio-frequency circuit at the resonance, and phase and the frequency changes are caused by its real part.

Except the aforesaid staggering of the oscillatory circuit the phenomenon of frequency capturing is observed at changing (modulating) the invariable magnetic field through the resonant value analogous picking-up the oscillations in the tube or the transistor oscillator by exter-

nal force. In this case the system of the nuclear magnetic moments acts like the external force. It is possible to consider it as the high-Q resonant circuit which interacts with the marginal oscillatory circuit. However, in this case there is no the perfect analogy. This interaction differs from that of two connected oscillatory circuits. Therefore frequency deviation connected with magnetic field change allows comparing this phenomenon with frequency capturing instead of frequency pulling observed in two connected oscillatory systems [6].

The marginal is an oscillator operating under the scheme of "an induction three-point (Hartley oscillator)" or of "a capacitor three-point (Colpitts oscillator)" [1 - 5] theory which is well developed [7, 8]. According to the theory for generating the self-oscillation a two-pole net with negative differential resistance is necessary to be connected to the oscillatory circuit

$$I(u) = S_1 u + S_3 u^3 + \dots, \quad (4)$$

where  $S_1 < 0$ .

From this theory it also known that stable inherent oscillations arise at increase of factor of feedback  $\beta$  to some critical value  $\beta_{cr}$ , i.e. at

$$\beta > \beta_{cr} = \frac{R_0 C}{S_1 L_0} = \frac{1}{S_1 R}, \quad (5)$$

here  $R_0$  and  $C$  - parameters of the parallel oscillatory circuit,  $R_0$  - (real) resistance of the coil,  $R$  - entering (equivalent) resistance of the circuit at the resonance. (The expression (5) doesn't consider transistor influence.) As appears from (2) at the nuclear magnetic resonance equivalent resistance of the parallel circuit decreases. According to expression (5) it leads to increase in critical value of feedback factor  $\beta_{cr}$ . So for the value of feedback factor  $\beta_0$  established in the generator the amplitude of oscillations will decrease.

And under the influence of destabilizing factors the self-oscillations in oscillators are the oscillations with random amplitudes and phases

$$u(t) = A(t) \cos(\omega t + \varphi(t)), \quad (6)$$

where  $A(t)$  and  $\varphi(t)$  are time stochastic functions.

The marginal scheme feature is that its sensitivity increases when the oscillation amplitude reduces [2, 7]

$$E(t) \approx \frac{dA(t)}{dS_1} \propto \frac{1}{A(t)}. \quad (7)$$

As consequence there are fluctuations of the sensitivity and the NMR signal amplitude.

The feature of the marginal is that it generates voltage with small amplitude (therefore it is still named the oscillator of small oscillations). In this operating mode even very small changes of parameters of an oscillatory circuit

lead to considerable variations of voltage amplitude generated by the marginal.

The phase locked-loop (PLL) is tuning the frequency of the parallel oscillatory circuit to its resonance value and conductivity of the circuit at the resonance is

$$G \approx \frac{1}{R} (1 - 4\pi Q \chi'' \xi), \quad (8)$$

here  $R$  is a resonant resistance of the circuit without NMR sample

From this formula it is obvious that PLL allows to exclude influence of the real part of susceptibility  $\chi'$ , there-

fore there will be no impurity of a dispersion component in the output signal.

The phase and amplitude locked-loops are included with the purpose of increasing the stability of the scheme function and carrying out the precision magnetic measurements.

It is necessary to notice there is an optimum frequency of invariant magnetic field modulation for each HF oscillation level. Application also of higher frequency modulation (in the range 10 – 100 kHz) promotes suppression of noise of a kind 1/f [1 – 3, 6, 8].

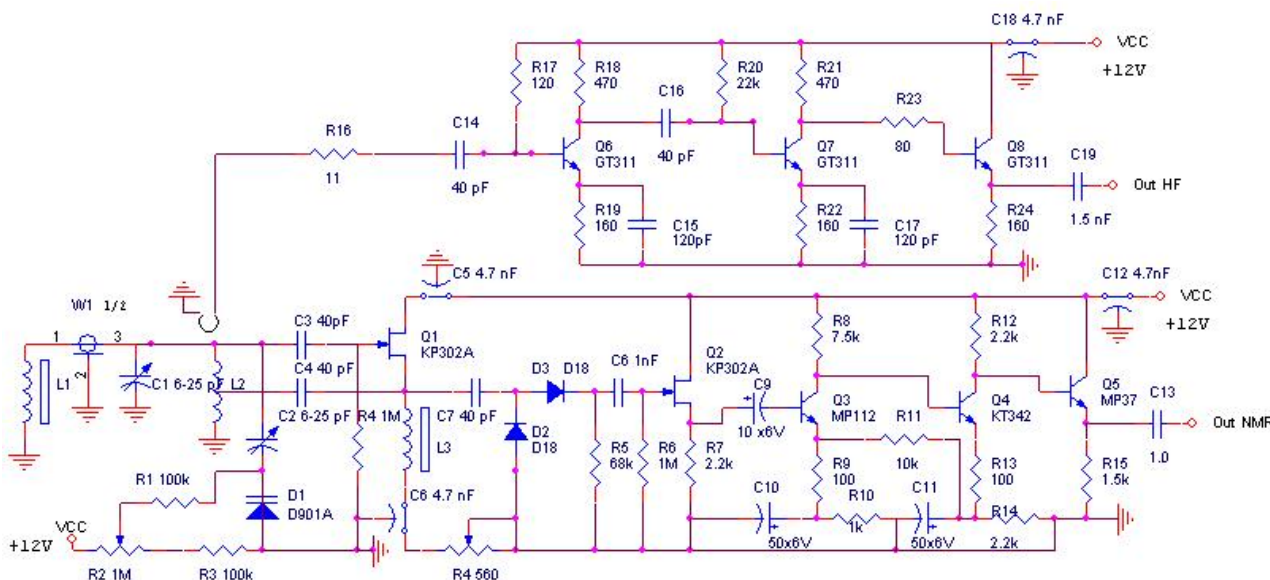

Figure1: The NMR magnetometer on the base the marginal oscillator with using FET.

### FET MARGINAL SCHEMES

The nuclear magnetic resonance magnetometer (Fig. 1) is one of the first magnetometers on a basis of the marginal with application field-effect transistors [10]. It is developed in 1973 for field control in the superconducting solenoid made for use in the proton polarized target which is applied to research of spin effects in the high energy physics. It is the classical scheme. Actually the marginal oscillator functions on the transistor Q1. The peak detector is assembled with application diodes D1 and D2, on transistors Q2 - Q5 the amplifier of low frequency is designed, on transistors Q6 - Q8 the high-frequency amplifier is built. The probe is connected to the device by cable RC-50 which length  $\lambda/2 = 2.5$  meters, operating frequency  $F = 30 - 40$  MHz. At increase in values of circuit elements it is possible to lower working frequency to  $\sim 5$  MHz. Further the transistors possessing the best characteristics (KP 303, KP 307) were applied. In this case at corresponding reduction of length of a cable operating frequency can be considerable above.

The signal of electron spin resonance (ESR) received by this scheme in  $\alpha$ -diphenyl- $\alpha$ -picriligidrazil (DPhPG) containing free radicals is shown on Fig. 2. The alternating magnetic field with frequency 50 Hz is created by the coil, the working frequency of the marginal is  $f = 30$  MHz, the signals ESR arise in the field  $\sim 10$  Gauss.

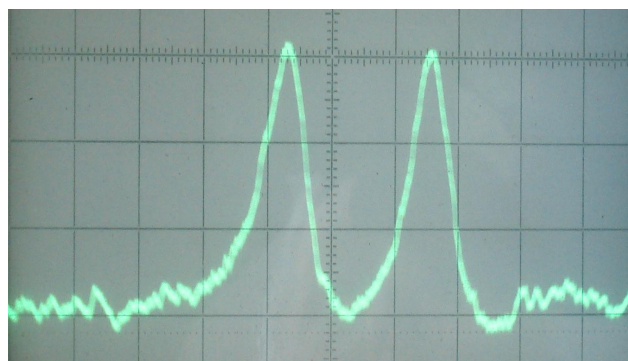

Figure 2: The signal of electron spin resonance in alternating magnetic field obtained by the scheme on fig. 1. Substance of the probe is  $\alpha$ -diphenyl- $\alpha$ -picriligidrazil (DPhPG).

Fig. 3 is presented the scheme of the simplest spin detector with operating frequency 150 MHz [11]. The resulted length ( $L = 0.32$  m) of the connecting cable of type RC-75 is equal to a quarter of the length wave ( $L = \lambda/4$ ) in it. The device distinguishes the minimum quantity of units.

On the basis of scheme Pound - Knight marginal is developed the device with the phase and amplitude locked-loops (Fig. 4). The Pound - Knight oscillator is collected on transistors Q1 - Q3. The amplitude locked-loop consists from the HF amplifier A1, the peak detector AD, the amplifier of direct current U1, Q2 - Q4 transistors. The phase locked-loop includes the HF amplifiers A1, A2, the phase detector PD, the stable (quartz) generator SF.

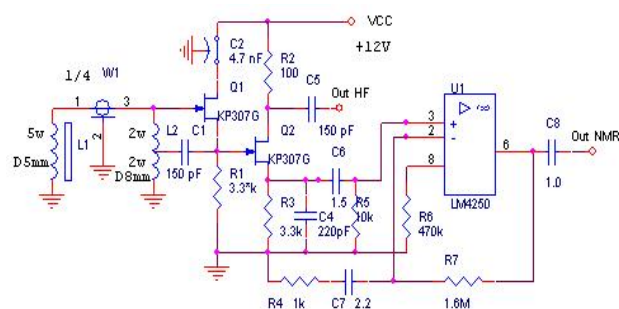

Figure 3: The elementary marginal detector.

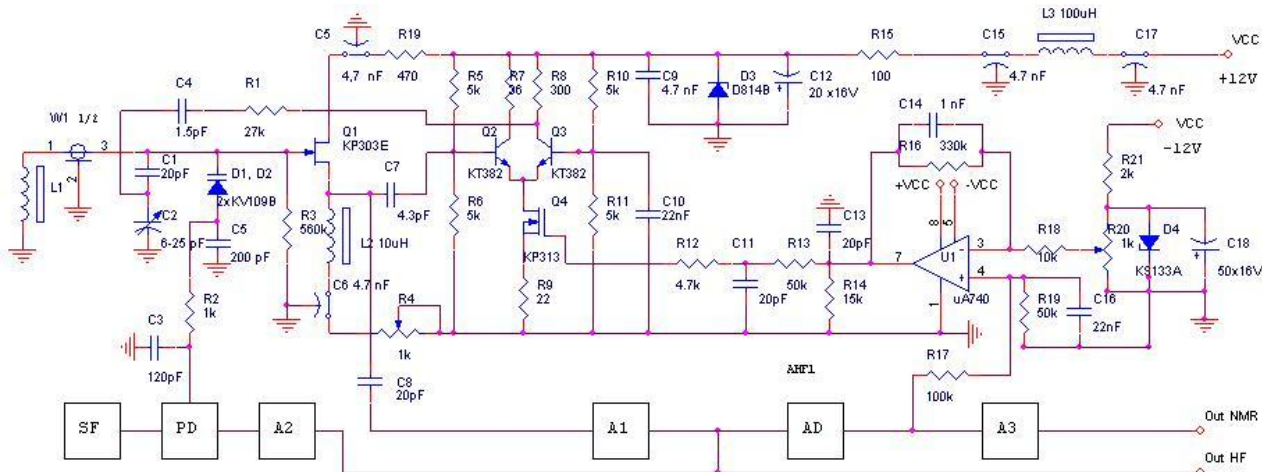

Figure 4: The NMR magnetometer on the base Pound - Knight marginal. A1 is HF amplifier, A2 - HF amplifier-terminator, AD - peak detector, PD - phase detector, SF - frequency synthesizer.

Operating frequencies range is 30 - 50 MHz, at replacement of inductance and capacity in the oscillatory circuit it is decreased to  $\sim 2$  MHz. Long-term ( $\sim 6 - 8$  hours) stability of frequency is better  $10^{-7}$  if the frequency synthesizer Ch6-31 is used. The generation minimum level is  $\sim 5$  mV.

## CONCLUSIONS

FET marginal facilities are the third generation of oscillators after tube schemes and bipolar transistor schemes.

Advantage of this scheme is high input resistance FET which as well as in case of tubes shunts an oscillatory loop a little and so its quality is reduced only a little. High quality oscillatory circuit causes the maximum modulation HF carrier.

PLL application of the oscillatory circuit allows to obtain the pure signal of the absorption which have been not deformed by dispersion. The amplitude locked-loop raises the relation of a signal to noise. It allows to increase accuracy of magnetic induction measurements.

The further improvement of device characteristics is connected with application of methods: synchronous de-

tecting, digital accumulation and averaging of signals, improvement of processing algorithms.

## REFERENCES

- [1] Andrew E.R., "Nuclear magnetic resonance", Cambridge at the University Press, 1965.
- [2] Lösche A., "Kerninduction", Veb Deutscher Verlag Der Wissenschaften, Berlin, 1957.
- [3] Howling D.H., "Signal and noise characteristics of the PKW marginal oscillator spectrometer.", Rev. Sci. Instrum., 1965, v.36, No.5, p. 660-667.
- [4] Pierce W.L. and Hicks J.C., "Improved NMR prober for magnetic field measurements", Rev. Sci. Instrum., 1965, v. 36, No. 2, p.202-203.
- [5] Idoine John D., Brandenberger Jr. and J.R., "FET marginal oscillator circuit", Rev. Sci. Instrum., 1971, v.42, No.5, p. 715-717.
- [6] Pomerantsev N.M., Ryzhkov V.M., Scrotsky G.V., "Physical bases of quantum magnetometry.", (in Russia), "Science", Moscow, 1972, p.448.
- [7] Tietze U., Schenk Ch., "Halbleiter-Schaltungstechnik", Springer-Verlag, Berlin-Heidelberg-New York, 1980.
- [8] Zernov N.V. and Karpov V.G., "Theory of radio engineering networks", (in Russia), "Energy", Leningrad, 1972, p.816.
- [9] Adler M.S., Senturia S.D. and Hewes C.R., "Sensitivity of marginal oscillator spectrometers.", Rev. Sci. Instrum., 1971, v.42, No.5, p. 704-712.
- [10] Parphenov L.B., Ryzhov V.G., Unpublished data.
- [11] Maximov A.Yu., Ryzhov V.G., Unpublished data.