

A Bunch Lengthening RF Cavity for Aladdin

K. J. Kleman
Synchrotron Radiation Center, University of Wisconsin – Madison
3731 Schneider Drive, Stoughton WI 53589 USA

Abstract

A 202 MHz aluminum rf cavity has been constructed for the Aladdin synchrotron light source* at the University of Wisconsin – Madison. The cavity operates on the fourth harmonic of the ring rf frequency and will be used to lengthen the electron bunches in order to increase beam lifetime. The cavity body is machined from a thick aluminum plate with a single penetration for the coupling loop which operates in vacuum. A cover plate at the gap end contains an annular tuner that is moved concentric with the beam axis. The entire inner surface of the cavity is copper plated to increase shunt impedance. The cavity will be initially operated in the beam driven mode with the tuner adjusted by computer to provide optimum bunch lengthening as the beam decays. In the future, active rf drive may be employed to allow a constant bunch length to be maintained at all times. A beam derived rf reference is proposed along with use of rf feedback to avoid instabilities. Results of the first storage ring operation using the new cavity are presented.

I. INTRODUCTION

The Aladdin synchrotron light source is a 0.8 - 1 GeV electron storage ring with four 4 meter straight sections for insertion devices. It is desired to increase beam lifetime when operating at 0.8 GeV to improve the integrated flux delivered to the experiments. This can be accomplished by diluting the longitudinal phase space in order to reduce intrabeam scattering. A higher harmonic RF cavity can be used to flatten the potential in the main RF bucket causing an increase in the bunch length. This occurs without an increase in the transverse emittances. For the present the cavity will be operated in the beam driven mode, with the cavity detuned to make its voltage appear approximately 90 degrees out of phase with the bunch passage.

A. Choice of Frequency

Several considerations are important when choosing the desired harmonic for the cavity. First, the cavity must fit into the available space in the ring. Also its shunt impedance must be high enough to allow the beam to develop the necessary rf voltage. The lower limit on the shunt impedance is determined by the minimum beam current at which the cavity is expected to operate with optimum results. If the cavity impedance is not high enough the cavity will have to be tuned closer to resonance in order to develop the proper voltage. As the cavity is brought closer to resonance the beam will become unstable, thus limiting the available range of tuning angle.

The choice of harmonic also affects the voltage required to achieve a flat potential well. The relationship between the

two cavity voltages required to flatten the potential well for a particular harmonic number n is

where V_H and f_H are the harmonic cavity voltage and frequency, and V_F and f_F are the fundamental cavity voltage

$$\frac{1}{n} = \frac{V_H}{V_F} = \frac{f_F}{f_H},$$

and frequency. The required voltage is lower for a higher harmonic, but the width of the flat portion of the potential is narrower. A low harmonic is therefore desirable for optimal bunch lengthening.

Calculations indicated that the cavity should perform properly if the tuning angle is greater than 85 degrees [1,2]. The minimum beam current the cavity is expected to operate at is 100 mA. The fundamental rf system of Aladdin operates at 50.582 MHz with a nominal cavity voltage of 80 kV. The minimum shunt impedance is given by

$$R_{\min} = \frac{V_F \tan(\psi_{\min})}{2nI_0}$$

Operating the cavity at the third harmonic would have been our preferred choice but the cavity would then not fit in the space available in the ring if designed to have the required shunt impedance. This led us to choose the fourth harmonic (202.4 MHz) as an acceptable compromise between high shunt impedance, low field and good bunch lengthening. The minimum shunt impedance for $n=4$ and $I_b=100$ mA is 1.2 M Ω .

The low energy (108 MeV) injection mode of Aladdin imposes additional requirements on the tuning range of the cavity. The main rf cavity voltage at injection is quite low (~9 kV). This means that the fourth harmonic cavity must be detuned enough to keep its voltage lower than 2 kV. The tuner was designed for a tuning range of 2.5 MHz to satisfy this requirement.

II. CAVITY DESIGN

A. General

The cavity (Fig. 1) is a single ended design with an annular tuner in the cover plate that is concentric with the beam axis. It is constructed entirely from 6061 aluminum alloy. The body of the cavity was machined from a single piece of 25 cm thick plate. The cover was machined from 5 cm plate. The vacuum seal for the end cover is a 0.75 mm aluminum wire. The cover also contains the penetrations for pump ports and sampling loops. The pump ports are covered by grids machined into the inner surface of the cover plate. Pumping is provided by two miniature 60 l/s ion pumps. A single penetration is located in the rear wall of the cavity body to accommodate a coupling loop for use when the cavity is actively driven.

* Work supported by the NSF under contract DMR-92-12658

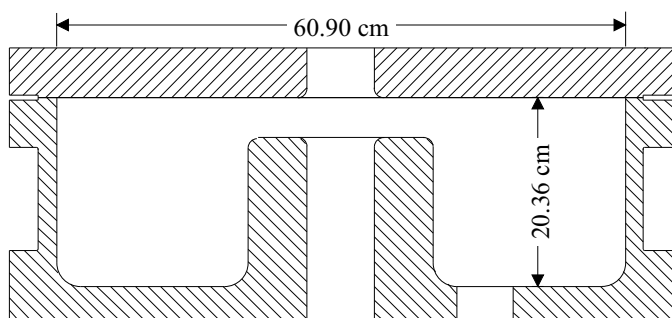

Fig. 1. 202 MHz Cavity Outline

Since the conductivity of 6061 alloy is only 40-45% that of copper, it was necessary to plate the entire inner surface of the cavity with copper to obtain sufficient shunt impedance. The plating was done by Industrial Plating Co. of Seattle, WA. The plating process used has been previously employed on accelerating cavities with excellent results [3,4].

Resonant Frequency	202 - 204.5 MHz
Q_u (calculated)	22000
Q_u (measured)	20250
R/Q	61.1
Shunt Impedance	1.24 M Ω as constructed

Table 1. Harmonic Cavity Parameters

B. Tuner

The tuner (Fig. 2) is a cylindrical copper slug centered on the beam axis through which the beam passes. The end of the tube is threaded onto the moving part of an actuating section of 304SS pipe that is part of the ring vacuum chamber. The pipe is allowed to move through the use of differential bellows. The return for tuner currents is via a ring of 18 flat U-shaped straps fabricated from silver plated 100 μm thick beryllium copper. The mechanical range of the tuner is about 2 cm with a sensitivity of about 1 MHz/cm.

The original design of the tuner used a spring ring as a sliding contact for the tuner return current. This approach was abandoned after it was found that the lifetime of the contact surfaces was very short, resulting in increased friction. The new design requires no maintenance and is much easier to align in the bore of the cover plate.

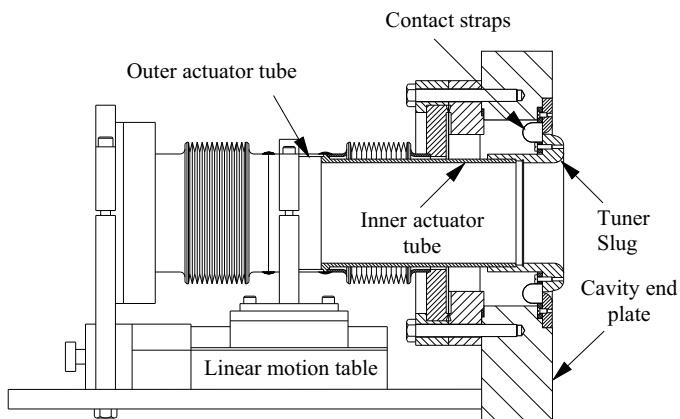

Fig. 2. Tuner Assembly

The cavity is tuned by moving the tuning slug in and out via a stepper motor driven table containing a fine pitch lead screw. The motor is controlled via an analog feedback loop. A conductive plastic linear potentiometer is used for the feedback element. The stepping motor drive contains a voltage controlled oscillator that allows the motor to be driven accurately at low speeds. The resolution of the feedback loop is limited only by the noise on the feedback voltage.

C. Anti-Multipactor Coating

The delicate nature of the stored beam at the injection energy caused some concern about multipacting at low cavity voltage. Since the cavity is passive we are unable to control the drive to the harmonic cavity to permit jumping through the first order multipactor level. In order to reduce any problems to manageable levels we coated the accelerating gap area with a layer of titanium. This was applied via sublimation from a pair of wires held in a fixture that was rotated about the beam axis. The pressure during sublimation was between 10^{-4} to 10^{-5} torr. The cavity was backfilled with nitrogen after sublimation to promote the formation of titanium nitride on the surface. Admittedly this is not an efficient process as the chamber contaminants will certainly form other titanium compounds before backfilling, but the coating formed performs its intended function quite well. The coated cavity was conditioned for about 12 hours. After conditioning, passing through the first order multipactor level during a slow power sweep caused only a small pressure rise without hysteresis effects.

III. OPERATION

A. Procedure

The cavity is set to a detuned condition at injection. After the beam has been stacked and ramped to the operating energy, the cavity is tuned to an approximate starting position and then stepped slowly toward resonance via computer control. The computer monitors the cavity voltage and adjusts the tuner in small steps as required to bring the voltage up to the operating value. The tuning process is stopped when the beam has decayed to the point where additional tuning would cause beam instability.

B. Operational Results

The cavity was installed in the storage ring for a brief period before being removed for the tuner modification mentioned above. The storage ring vacuum did not have much opportunity to recover during the test period. Beam lifetime with the cavity detuned had recovered to about 75% of its nominal value at the time of the test.

Injection proceeded well with the cavity detuned about one half of a revolution frequency (~ 1.6 MHz). Numerous higher order modes, resulting in both bunch lengthening and transverse emittance growth were observed as the cavity was tuned toward resonance, especially while operating at high energy. HOM induced disturbances were smaller at injection because the naturally long bunch (~ 2 ns) at injection does not excite the higher frequency modes effectively.

As the cavity was brought close to resonance the bunch began to lengthen smoothly. At the optimum tuning angle the bunch assumed a pseudo-trapezoidal shape (Fig. 3). Further tuning produced a bunch with a double peak, as expected. Shortly after this point the Robinson instability would set in, with further tuning resulting in beam loss.

The effectiveness of the cavity was impressive, considering the poor state of the storage ring vacuum. When the cavity was optimally tuned the 0.8 GeV lifetime was increased by 70% at 150 mA of beam current. The cavity was able to optimally lengthen the bunch down to currents of approximately 120 mA without instability. The lifetime at 100 mA was 90% of the value obtained at 120 mA when tuning was ceased at that current. These numbers agree well with the computed predictions.

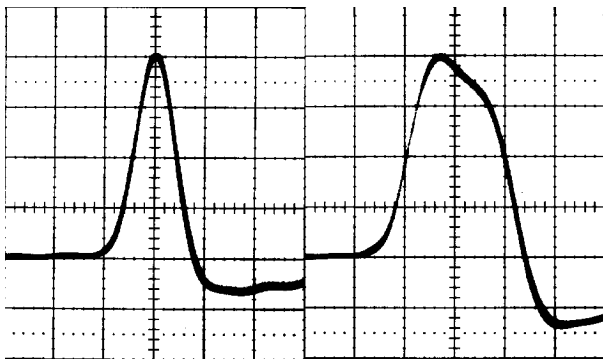

Fig. 3. Longitudinal bunch profiles (1 ns/div) with harmonic cavity detuned (left), and tune for optimal bunch lengthening (right). Droop is due to a capacitive pickup.

IV. ACTIVE OPERATION

It is envisioned that active operation of the cavity may be desirable at some time in the future. Problems caused by the equilibrium phase instability in actively driven bunch lengthening cavities are well documented [5,6]. When operating at lower currents the Robinson instability must also be avoided. To address these difficulties the proposed system will use two techniques to enhance stable operation.

The rf drive signal for the cavity will be obtained from a beam pickup. The pickup signal will be limited to eliminate amplitude variations. The limited signal contains beam phase information and therefore will act to make the harmonic cavity phase follow the beam phase, reducing the coupling between the beam and harmonic cavity. This can also be accomplished by phase locking the RF drive from a generator to a beam derived signal, although with more difficulty.

The phase tracking can be improved by the use of proportional rf feedback around the amplifier/cavity system. This will have the effect of lowering the apparent cavity Q and shunt impedance by a factor of $(1+Gain)$. This technique reduces beam coupling at frequencies up to the bandwidth of the feedback loop.

Steady state control of the harmonic cavity field will be provided by a conventional amplitude and phase control loops

operating off a cavity pickup signal. These loops do not have to be very fast because the rf feedback stabilizes the cavity fields at high frequencies.

Since a pure bunch lengthening cavity does not provide any net energy to the beam, the beam loading in the active case should be entirely reactive. It is easy to show this implies that the generator current vector will be perpendicular to the beam current vector and that the cavity appears as a constant resistive load when it is tuned correctly. The situation is similar to the that of an accelerating cavity in the reactively compensated condition at zero energy gain. The only differences are a 180 degree phase shift of the cavity voltage and a sign change in the tuning angle. Operating the cavity in this way also eliminates the equilibrium phase instability at high current because it approximates the passive case which is unconditionally stable in the high current limit.

To accomplish this a standard tuner control loop will be used with feedback being taken from a directional coupler in the cavity drive line. The forward signal from the coupler is phase compared with the signal from a cavity pickup and used to control the tuner drive. The tuner loop automatically compensates for the changing reactive load as beam current varies.

V. SUMMARY

A copper plated aluminum fourth harmonic cavity has been installed in the Aladdin light source. The cavity approximately doubles the bunch length and provides a greater than 70% increase in the 0.8 GeV beam lifetime. Passive operation of the cavity has begun and is effective for currents greater than 100 mA. Active operation of the cavity has been planned for in the future if necessary. The cavity has fulfilled all of our expectations in tests and should be a very useful addition to the Aladdin facility.

VI. REFERENCES

- [1] R. A. Bosch, "Modeling a Landau Cavity at the Synchrotron Radiation Center", Synchrotron Radiation Center Technical Note, *SRC-118* (1993).
- [2] R. A. Bosch, "Modeling a Landau Cavity at the Synchrotron Radiation Center, Part II", Synchrotron Radiation Center Technical Note, *SRC-137* (1994).
- [3] H. Mignardot and J. Uher, *Proc. of the 1991 IEEE Particle Accelerator Conf.*, (1991) 777-779.
- [4] A. M. Vetter et al., *Proc. of the 1993 Particle Accelerator Conf.*, (1993) 1075-1077.
- [5] Y. Miyahara et al., *Nucl. Instr. and Meth.*, A260 (1987) 518-528.
- [6] J. Keane et al., *Proc. of the 1989 IEEE Particle Accelerator Conf.*, (1989) 138-140.