

STATUS OF THE HIGH BRILLIANCE SYNCHROTRON RADIATION SOURCE BESSY-II *

E. Jaeschke, S. Khan, D. Krämer, D. Schirmer for the BESSY II project team,
BESSY II, Rudower Chaussee 5, Geb. 15.1, 12489 Berlin, Germany

Abstract

BESSY II is designed as a high brilliance synchrotron light source in the VUV/XUV region with 1.7 GeV nominal beam energy. Being under construction at Berlin-Adlershof, the machine is expected to start routine operation in 1998. An overview of the status of the project is given.

I. INTRODUCTION

The synchrotron radiation (SR) source BESSY II is based on a 240 m circumference storage ring of 8-fold symmetry. Sixteen DBA cells provide alternating dispersion-free straight sections of high and low horizontal beta function and no dispersion. Thus, high flexibility is achieved to install various types of undulators, wigglers and also superconducting wavelength shifters [1] in max. 14 places. Six undulators and wigglers and two wavelength shifters will be available within the first two years after commissioning of the new SR source.

The injection system consists of a 50 MeV racetrack microtron (RTM), and a 10 Hz booster synchrotron which ramps the electron beam to its final operation energy of max. 1.9 GeV.

Prototypes of the magnets for the synchrotron were built at The Budker Institute for Nuclear Physics, Novosibirsk and a complete unit cell was received and tested recently [2].

Prototypes of the storage ring magnets (32 dipole, 144 quadrupole and 112 combined function sextupole and correction magnets) are expected for mid of 1995. Delivery of all elements is scheduled for the 2nd half of 1996.

Major progress has been made concerning the storage ring vacuum system and a prototype section (1/16 of the whole system) will be available in July this year. The vacuum components for the injector have been ordered. Their installation will start in beginning of 1996 followed by the the storage ring approximately six month later.

II. BUILDINGS

The buildings activities have started in September 1994 and are progressing according to the time schedule. An experimental hall of 1000 m² for assembly and measurements been completed recently. The building is now, for example, used for magnetic measurements, rf tests and commissioning of the 50 MeV RTM. Previously existing buildings have been renovated and are in use since March 1994.

The main experimental hall of 120 m diameter with the storage ring tunnel and experimental area is under construction and casting of concrete is expected to be finished in July 1995. This will allow to start the installation of the machines on a large

scale by the end of this year. Final assembly of the storage ring is schedule for mid of 1997 allowing to start commissioning of the storage ring in late 1997. First light from an undulator is expected at the end of 1997.

III. THE STORAGE RING

A. Magnets

Prototypes of all storage ring magnets (dipoles, quadrupoles, sextupoles) were designed and all major orders were placed. Delivery of the pre-series bending magnets and multipole magnets is scheduled for mid of this year. After careful measurements and optimizations of the chamfers by BESSY, the series production will start in Autumn 1995. The storage ring magnet design and the expected magnetic performance is discussed in [3].

B. Storage Ring Injection System

The injection components, comprising 4 fast kicker magnets and the injection septa are located in one of the high beta sections ($\beta_x \approx 17$ m) of the storage ring. The kickers, driven by sine half wave pulsers, will displace the closed orbit by 17 mm. Two septum magnets will inject the beam coming from the synchrotron ($\epsilon = 1.7 \cdot 10^{-7}$ rad m). In order to increase the injection efficiency, detailed calculations were carried out to optimize the optics of transfer line and the injection parameters [4], [5]. The calculated efficiency for a matched beam is 98%. Table I summarizes the main magnet parameters of the injection elements and Figure 1 shows their geometrical arrangement. Since the injection system of ELETTRA is rather similar, it was agreed that Synchrotrone Trieste will manufacture the complete injection system (septa, kicker, pulser).

The layout of the transfer lines is finalized and the specifications of all components are ready for call for tender. A detailed description is given in [5].

	kicker 1-4	septum 1	septum 2
pulse length	5 μ s	40-50 μ s	40-50 μ s
magnetic field	0.24 T	0.750 T	0.761 T
deflection angle	20.9 mrad	65.8 mrad	66.8 mrad
peak current	8413 A	8962 A	9090 A
capacitor charging			
voltage	9.796 kV	1058 V	1073 V
core length	552 mm	555 mm	555 mm
overall length	595 mm	595 mm	595 mm

Table I
Parameters of the storage ring injection components.

*Funded by the Bundesministerium für Bildung, Wissenschaft, Forschung und Technologie and by the Land Berlin.

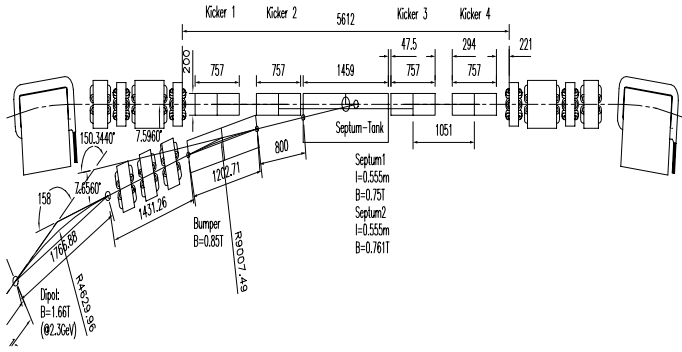

Figure 1. Storage ring injection region.

C. Vacuum Chamber and Girder Layout

Theoretical investigations and computer simulations concerning the beam lifetime and impedance-driven instabilities have helped to finalize the vacuum chamber layout. Being a major threat, transverse coupled bunch instabilities (resistive wall effect) have been investigated analytically and with numerical simulations. The beam lifetime, limited by the Touschek effect as well as residual gas scattering (Coulomb scattering and Bremsstrahlung) is expected to be at least 10h at 1.7 GeV, assuming a mean vacuum pressure of $2 \cdot 10^9$ mbar N_2 equivalent and a momentum acceptance of 3%. As a consequence of these investigations, the beam pipe aperture was chosen to be ± 35 mm horizontally and ± 17.5 mm vertically. The minimum vertical wiggler/undulator gap has been fixed to ± 8 mm which reduces the lifetime due to Coulomb scattering only little. Keeping the resistive wall effect in view [6], the ID chambers will be made of aluminium.

The different vacuum chamber profiles for the dipole, quadrupole and ID region are shown in Figure 2. A prototype vacuum section (1/16 of the whole system) has been ordered and will be available for testing mid of this year.

The proposed BESSY II vacuum chamber is made of stainless steel with a copper absorber all around the circumference

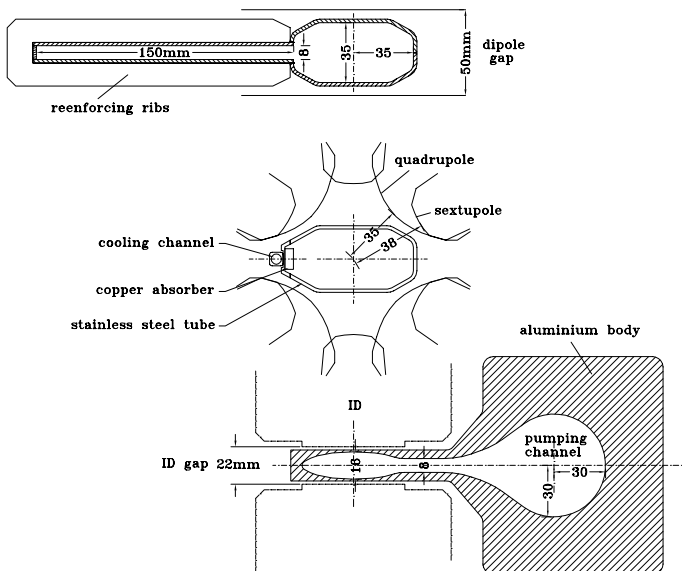

Figure 2. Cross sections of the different vacuum chambers in the dipole, quad and ID region.

to reduce the maximum temperature on the chamber due to SR power. The copper absorber will be brazed or explosively bonded to the chamber and indirectly cooled from the outside. Finite element calculations including the effect of scattered photons show that max. absorber temperature is 10° above the cooling water temperature. There will be no antechamber except in the ID region and in the dipole chamber. The mechanical stability of the dipole chamber has been checked by finite element simulations. With the inclusion of reinforcing ribs, the maximum distortion due to the atmospheric pressure is 0.1 mm for a chamber of 2 mm wall thickness. The pumping concept for BESSY II includes a 400 l/s ion getter pump for each crotch absorber, and three to five ion getter pumps of approximately 75 l/s in the straight sections outside of the IDs. The pumping scheme in the IDs depends on their respective design. NEG-cartridges and Ti sublimator pumps are considered as an option to be installed in the vicinity of the crotch absorbers.

The elements of each storage ring DBA-cell will be mounted on 3 girders made of concrete blocks, which are expected to damp vibrations more effectively than metallic structures. Extensive tolerance studies [7] were performed to optimize the girder scheme with respect to the sensitivity of the installed lattice elements to coherent movements of the assembly. The result is shown in Figure 3.

The magnetic elements will be mounted on the girders and aligned prior to their installation in the tunnel, where the final alignment of the complete girders will be done.

There are 3 SR beam lines emerging from the first dipole chamber, one for the respective ID and two for SR from the dipole, while the second dipole chamber is, for geometrical reasons, equipped with 1 SR outlet only. Seven BPMs per cell form an integral part of the vacuum system. Their positions coincide with the fixed points of the chambers which may undergo deformations due to the received heat load. They are mechanically decoupled from the magnets in order to avoid mechanical stress and displacements of the optical elements which would create closed orbit distortions.

D. RF system

Major progress has been made on the rf sector. It was decided to use four already available DORIS type single cell cavities which will be installed in one of the low beta straight sections. The pill box shaped resonators will be fed by individual 500 MHz generators making use of Thompson TH2123

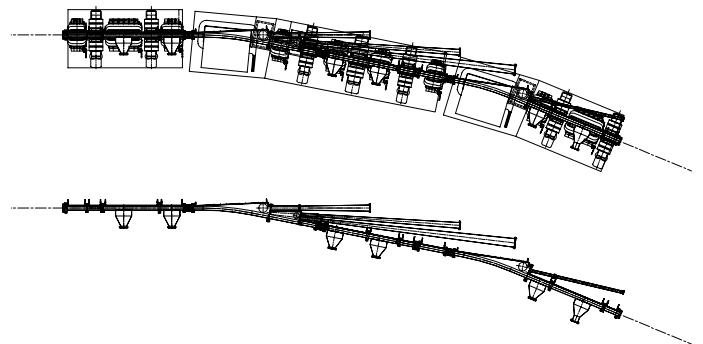

Figure 3. Top view of the girder scheme and the vacuum system.

klystrons with a power of 75 kW each. All rf generators are ordered and the first one is expected to be delivered in June 1995.

E. Diagnostics

The availability of suitable beam diagnostics is a crucial prerequisite for reliable and smooth operation of the machine. The relative accuracy of each of the 112 BMPs is $5 \mu\text{m}$, their absolute position error is 0.1 mm. For the first turn, a fast albeit less accurate mode of measuring is foreseen.

SR light monitors attached to one of the dipole radiation sources will allow to image the beam. For intensity measurement, a Bergoz PCT-175 is already being tested.

Foil monitors, scrapers and various striplines are foreseen in a separate straight section.

IV. MICROTRON AND BOOSTER

A. Booster Prototype Magnets

The dipoles and quadrupoles of the full energy booster are presently manufactured by the Budger Institute for Nuclear Physics (BINP), Novosibirsk. A prototype of a complete booster FODO cell has been delivered in April 1995. First magnetic measurements of the booster prototype magnets (2 quadrupoles and 1 dipole) gave excellent results with respect to mechanical tolerances, field homogeneities and higher order multipoles. A detailed description of the magnetic measurements is given in [2].

B. Microtron Recommissioning

A Scanditronix 50 MeV racetrack microtron will be used as a pre-injector to feed the 10 Hz booster synchrotron. This microtron was recommissioned in March 1995. Already at the first test run produced an electron beam pulse after 9 turns which was detected using a faraday cup (Figure 4). The data correspond to a beam energy of 50 MeV, a current of 9 mA and a pulse length of $1 \mu\text{s}$. Additional diagnostics to simplify its operation will be added to the machine, e.g. an internal video signal monitor and computer control. Work is in progress to upgrade the RTM with a triode gun to produce 1 ns pulses and with a 500 MHz subharmonic buncher to be able to operate the storage ring in single bunch mode. The main design parameters of the microtron are summarized in table II.

References

- [1] G. Wüstefeld, B. Kuske, V. Sajaev, D. Schirmer *Optimization and Tracking Studies for the 1.7 GeV Light Source BESSY II*, EPAC, 1994, London
- [2] I. Chertok, T. Knuth, D. Krämer, E. Weihrer, *The Magnetic Lattice of the BESSY-II Injector Synchrotron*, these proceedings
- [3] T. Becker, V. Korschuganov, D. Krämer, S. Küchler, N. Kuznetsov, E. Levichev, U. Strönisch, *Prototype Development of the BESSY-II Storage Ring Magnets*, these proceedings
- [4] D. Krämer, R. v. Hahn, *Injektion in den Speicherring*, Technical Note, TN9/BESSY II/03/95/RvH

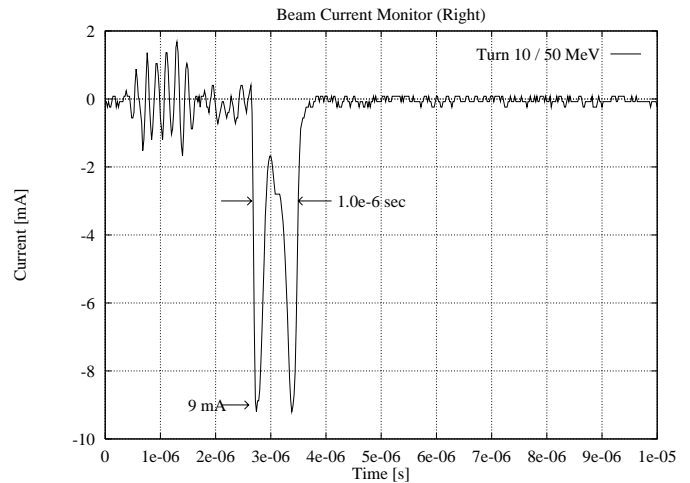

Figure 4. Electron beam pulse at the microtron exit.

Main RTM Parameters		
beam	max. energy	50 MeV
	max. current	28 mA
	energy width	0.5%
	emittance	$< 0.5 \text{ mm} \cdot \text{mrad}$
	pulse	$1 \mu\text{s}, 10 \text{ Hz}$
system	gun	100 kV, 600 mA
	RF	2998 MHz
	klystron (in/out)	100 kV, 140 A / 6 MW
	dipole	1.0479 T
	energy gain/turn	5 MeV
	no. of turns	10
tot. orbit length	$26 \text{ m} \hat{=} 72 \text{ ns}$	

Table II

Design parameters of the racetrack microtron.

- [5] D. Schirmer, M. v. Hartrott, S. Khan, D. Krämer, E. Weihrer, *Beam Transfer Lines at BESSY-II*, these proceedings
- [6] S. Khan, *Simulation of Transverse Coupled Bunch Instabilities*, these proceedings
- [7] G. Wüstefeld, *Estimate of the Closed Orbit Sensitivity of Different Girder Schemes for the BESSY II Storage Ring*, Technical Note, BESSY TB Nr.193/95