

VANE FABRICATION FOR THE PROOF-OF-PRINCIPLE RADIO-FREQUENCY QUADRUPOLE ACCELERATOR*

Steven W. Williams,** James M. Potter
Los Alamos National Laboratory, Los Alamos, New Mexico 87545

Summary

The electrodes for the Proof-of-Principle (POP) Radio-Frequency Quadrupole (RFQ) accelerator were machined on a numerically controlled, three-axis, vertical mill. These pole tips, or vanes, were prepared for, and used, in the successful demonstration of RFQ practicality at Los Alamos National Laboratory in February, 1980. The data set that described the vanes contained about 10 million bits of tool position data. The vanes were cut from OFHC copper blanks. The tolerances achieved were approximately ± 0.005 cm. The design and manufacturing procedures are described.

Introduction

The Los Alamos POP RFQ was the first such accelerator reported in the Western world.¹ Its operation culminated a two-year research and development

effort. The purpose was to enhance confidence in an RFQ design for the Fusion Materials Irradiation Test Facility (FMIT). As a result of this demonstration, many other programs have incorporated RFQ accelerators into their plans.

A cross section of the POP RFQ is shown in Fig. 1. It is basically an RF cavity with electrodes designed to focus, bunch, and accelerate a beam of protons. Correct vane shape is essential to obtain the proper field distribution required for acceptable performance.² This shape is described by an equipotential surface in the electrostatic solution for the structure. The quadrupolar symmetry produces focusing fields in the transverse plane. Longitudinal modulations create axial fields that provide the phase focusing and acceleration properties of the structure. Analytical description of the vanes is presented by Kapchinskii and Teplyakov. A representation of sections of the vane design is shown in Fig. 2.

The vane geometry is specified by three parameters: cell length (CL), modulation factor (m), and axis-to-electrode radius (a). These vary continuously down the length of the vane and are shown in Fig. 3. The values of a, m, and CL result from analysis that uses the beam dynamics code PARMILA. The pole-tip radius of curvature (R) is the fourth

*Work performed under the auspices of the US Department of Energy.
**Hanford Engineering Development Laboratory employee

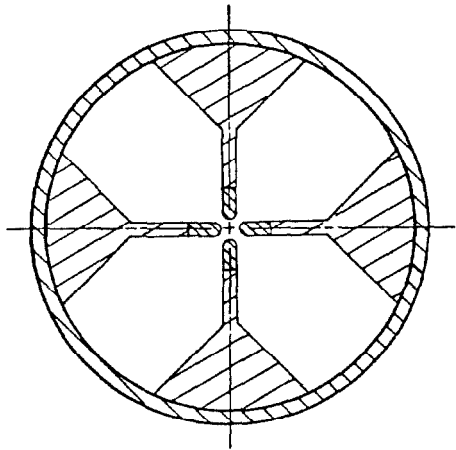

Fig. 1. POP RFQ cross-section.

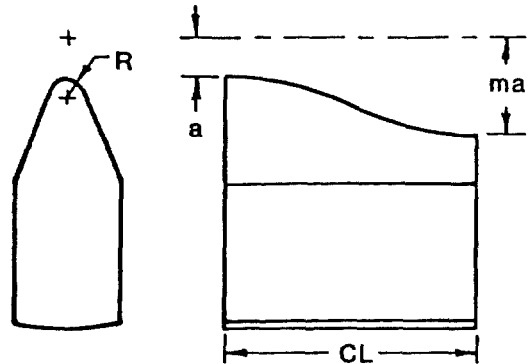

Fig. 3. Vane geometry parameters.

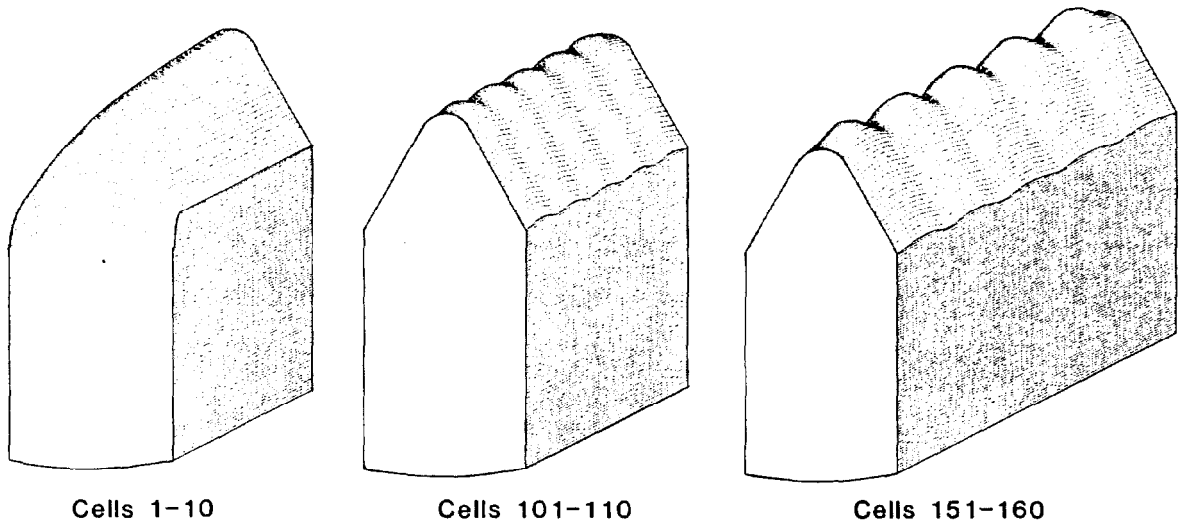

Fig. 2. Computer simulation of POP vanes.

important parameter, and is calculated using the values of the other three.

Criteria

The design of the POP vanes was based on the following parameters:

Table I
POP Vane Parameters

Ion	H ⁺
Frequency	425 MHz
Initial bore radius	0.200 cm
Final bore radius	0.126 cm
$\beta\lambda$ initial (0.10 MeV)	1.03 cm
$\beta\lambda$ final (0.64 MeV)	2.60 cm
Maximum modulation factor m	2.034
Vane length	110.8 cm
Number of cells	165

The values in Table I were primarily constraints associated with the beam-dynamics design. Other considerations were the fabrication tolerances that determined how closely the vanes approximated the analytical design, the surface texture required to stand off operating fields of 30 MV/m, and the vane-base contact that provided mechanical support and an RF electrical joint. Sensitivity studies showed the required fabrication tolerances to be about ± 0.008 cm. Cavity dimensions and breakdown data³ that indicated the microfinish required to withstand 30-MV/m fields was about ± 0.0001 -cm rms. The vane-base contact called for a secure, precise mechanical fit that created no discontinuities for the RF circuit.

Concept

The original idea (from J. M. Potter) for the fabrication scheme concept considered the vane as comprising a large number of transverse slices. These thin sections were to be machined sequentially down the length of each vane by a three-axis numerically controlled (NC) mill. A depiction of the travel path for a ball-end cutter is shown in Fig. 4. This pattern of tool travel was achieved by using only line segments and circular arcs.

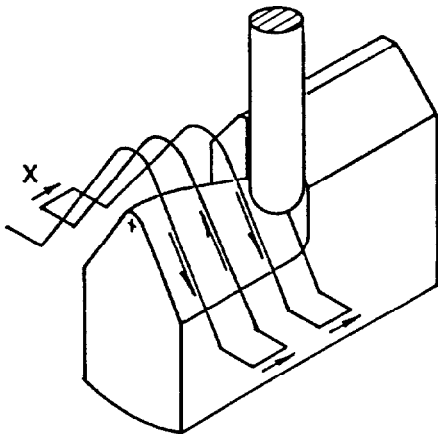

Fig. 4. Cutting path.

An EX-CEL-0 three-axis contouring machine was used because it was one of the most accurate NC machines in the Los Alamos shops and it was available for the RFQ project. An NC-type tool was called for because of the very close tolerances and the large

volume of data necessary for an adequate vane description. The tool controller required the cutter path to follow lines and arcs; thus, the convention of Fig. 4 was convenient.

The ideal shape at the pole tip is hyperbolic; therefore, the line/arc tool path provides only an approximation to the perfect contour. The deviation increases when a second source of error is considered.

The tool path would be identical to the cross section of the vane if the cutter had zero radius; however, the cutter must have positive radius. Figure 5 illustrates that the site of material removal does not generally lie in the plane of cutter travel. This error can be defeated to some degree by compensating the tool-position commands to create the proper profile and radius of curvature at the tip of the electrode.

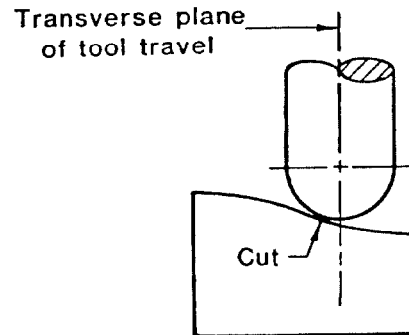

Fig. 5. Tool path error.

Engineering Development

The output from the PARMILA beam-dynamics analysis was a tabulation of values for a , m , and CL at the boundaries of the 165 cells. Because of the surface finish requirement for the electrode, the distance between slices (marked X in Fig. 4) was required to be about 0.025 cm. Thus, interpolation between the cell boundaries was necessary. The code CONFAB was written to perform the computations. This program also compensated the tool-position data for the path error of Fig. 5.

With the closely-spaced interpolations, 4453 lateral tool passes were necessary to describe one vane. Each pass comprised seven tool commands. Each command required about 25 characters of information in ASCII hexadecimal; thus, more than five million bits of tool data were required to cut one vane. Because there are two vane designs for any RFQ, the bit count was more than ten million.

The paper tape usually required to carry this much data is about 20 km. Instead, 14 cassette tapes performed this function. The interface between the cassettes and the paper tape reader was as follows.

First, the cassettes were written using a telephone link to the home computer of one of the authors. The data, as interpolated and corrected by CONFAB, were read from a file in the Los Alamos central computing facility and edited for use with the EX-CEL-0. The tapes were then transferred to a tape-reader-equipped keyboard which interacted with an Intel 8080 on board the NC mill controller. With correct prompting, the tape reader filled a buffer with tool commands and automatically refilled it as these commands were executed at the cutter.

Fabrication

OFHC copper was chosen as the vane material. Because copper is relatively tough and difficult to machine, and because tool wear was required to be minimal, a carbide cutter was used for the contouring. Six blanks were cut from 0.5 x 1.5 in. OFHC bar stock on a travelling-bed, template-controlled planer. The first operation on this machine cut the blanks to their final width of 1.199 cm. In the second operation, the vane-base radius of curvature was cut to the design value of 2.858 cm. The third and final operation removed metal from the blank's upper surface to produce slanted sides and a flat top for the envelope of the pole-tip contour. This envelope was longitudinally uniform and was everywhere at least 0.10 cm larger than the theoretical vane surface.

With the correct blank cross-section, the next step was to cut the vanes to length (110.84 cm) on a vertical mill. After that, twelve holes were drilled and tapped into the vane bases for mounting the blanks onto the milling fixture. Also, four holes were jig-bored into each vane to provide dowel-pin positioning and alignment.

For milling, the blanks were held in a fixture (Fig. 6). This device was made from 10 x 10 cm aluminum bar stock and cut to size on the EX-CEL-0 mill. It provided a clamping feature and a mounting surface for the curved vane bases. When measured with an indicator in the milling head, the total run-out for the fixture and machine bed was less than 0.0003 cm.

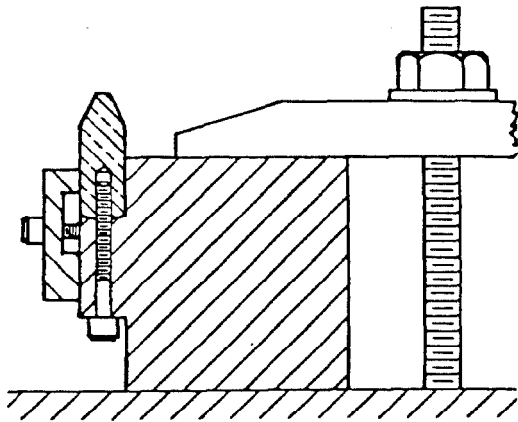

Fig. 6. Milling fixture cross-section.

The tool selected was a carbide-tip, ball-end cutter with a radius of 0.6350 cm. It was specially ground and inspected to be accurate within 0.0003 cm on the radius. The spindle speed was nominally 1000 RPM. As the cutter travelled its path, the tool center normally traversed at about 75 cm/min.

The vanes were cut in two longitudinal passes; one for roughing out the vane to a 0.03-cm envelope, and the other for finish cutting to the desired contour. The rough cut was required for bulk metal removal and used six transverse slices per cm for gross vane shaping. The finish cut was performed at forty slices per cm and resulted in a machined surface finish of 0.0005 cm.

After machining, the vanes were removed for inspection. Their dimensions were measured with an optical shadowgraph and a high-precision inspection mill. The fabrication error measured in the electrode surface was ± 0.004 cm.

In final preparation for use as RF high-voltage electrodes, the vanes were electropolished over the machined surfaces. The sides and bases were protected with masking during the process that removed approximately 0.0005 cm at the pole tips. After polishing and rinsing with ethanol, the vanes were wrapped in plastic and stored for installation in the RF cavity.

In Retrospect

At the time these vanes were made, there was no assurance any others would ever be required. Therefore, many of the details of their fabrication are not optimum solutions and most problems were handled with an expedient a get-it-done approach.

Having extra vane blanks proved useful. While cutting vane #3, a read error in the machine controller produced tool instructions which ruined the copper piece. The extra blank saved time and retooling effort. Including only direct fabrication expenses, the set of four vanes cost about \$16,000; but this does not include any of the expenses associated with the year-long development program preliminary to fabrication.

Acknowledgement

The authors would like to thank C. W. Fuller, L. S. Wampler, E. M. Riggs, A. J. Lopez, E. J. Andolsek, and O. A. Maier for their efforts and interest in this project.

References

1. R. W. Hamm, et al., "The RF Quadrupole Linac: A New-Low Energy Accelerator", Proceedings of the Intl. Conf. on Low-Energy Ion Beams 2, University of Bath, England (April 1980).
2. I. M. Kapchinskii and V. A. Teplyakov, "Linear Accelerator with Spatially Homogeneous Strong Focusing", Prib. Tekhn. Eksp., No. 2, 19-22, (1970).
3. S. W. Williams, R. F. DePaula, D. R. Keffeler, and G. W. Rodenz, "Voltage Breakdown at 420 MHz for an RFQ Structure", this conference.