

PERFORMANCE OPTIMIZATION OF A CUSP-FIELD ION SOURCE AND HIGH-PERVEANCE EXTRACTOR*

E. A. Meyer, D. D. Armstrong, and J. D. Schneider
Los Alamos National Laboratory, Los Alamos, New Mexico 87545

Summary

The injector for the Fusion Materials Irradiation Test (FMIT) Facility must deliver a 110-mA dc beam of deuterons or H_2^+ ions to the radio-frequency quadrupole (RFQ) accelerator at 75-keV energy. Operational parameters of a hydrogen-fed cusp-field ion source and a high-perveance extractor have been evaluated on a test stand and on the recently completed first stage of the prototype injector (Fig. 1).

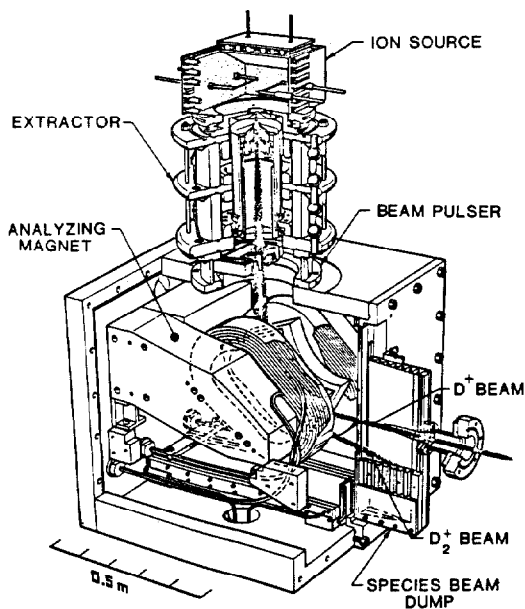

Fig. 1. First stage of the prototype injector.

Introduction

The injection-energy requirement for the RFQ accelerator was reduced from 100 keV to 75 keV to substantially reduce its length. Because the beam-current requirement was not changed, this reduced voltage required an extractor of even higher perveance. Electron-equivalent perveance is defined here as:

$$p = \sqrt{\frac{M_e}{e}} \frac{I}{\sqrt{V^{3/2}}}$$

where M_e = effective ion mass relative to electron mass
 e = number of electron charges/beam particle
 I = current in amperes
 V = particle energy in electron volts

The perveance of a 75-keV, 250-mA deuterium beam with a typical effective ion mass of 3×1836 is 0.90×10^{-6} amp/volt^{3/2}. This new requirement, as well as the poor beam quality obtained when scaling up the current achieved with an earlier version, necessitated a change in design.

All our previous extractor designs were based on a planar-Pierce geometry, with a 60% empirical correction factor applied to the Child-Langmuir space-charge limit.^{1,2} Electrodes designed by this technique² worked very well at 100 kV for apertures of 1 cm² and current densities of 100 mA/cm². However, poor quality beam resulted when we tried to double the current, either by doubling the current density or doubling the area. The limiting factor seemed to be the severe aberration in the highly divergent exit lens of the ground electrode.

Several designs were considered including an accel-decel system and multiaperture electrodes with subsequent convergence of the individual beamlets. The simplest method considered and subsequently adopted was a single-aperture, single-gap design that produced a spherically convergent beam. The larger area at the ion source plasma surface allows for low-emission current density. Beam convergence permits use of a small aperture at the ground electrode and provides compensation for normal beam divergence. The decision to switch to a spherically convergent Pierce geometry was strengthened by Brewer's³ report of success on high-perveance electron guns.

We made a series of computations to determine suitable electrode shapes to extract 240 mA of real current at 75 keV. Details of the spherical extraction design process will be described in a subsequent paper. Very simply, the method is that of determining the proper potential distribution along the beam edge and solving for the equipotential (electrode) shapes that can support the proper beam-edge potential distribution. A series expansion solving Laplace's equation using the spherical coordinates r and θ and Legendre polynomials given by

$$V(r, \theta) = \sum_{n=1}^{\infty} \left[A_n r^n + B_n r^{-(n+1)} \right] P_n(\cos \theta) ,$$

is used to fit the beam-edge potential. A similar technique was suggested by Mueller.⁴

Ion Source

The cusp-field ion source (Fig. 1) is a nearly cubical chamber (18 cm per side) with room for five rows of magnets along the sides and two square rings of magnets on the top plate. The source is cooled by water lines between the magnets and in the axial region on top. Two ac-heated filaments are used made of tightly wrapped 0.1-mm nickel gauze over a 1.0-mm tantalum wire and coated with a barium-strontium oxide.

Source efficiency tests were conducted varying the number of magnets on the sides, with and without flux return plates, and with single or double magnets. A two-dimensional analysis of the magnetic field in a cusp-field ion source, and the effect of this field on the ion motion in the plasma was developed. The analysis is based on an approach suggested by K. Halbach.⁵ The resultant equation relates the loss area for the ions and electrons to all the geometrical parameters that need to be considered in designing a cusp-field source. A few geometries have been calculated and compared to measurements of the performance of the ion source. The results can be

*Work performed under the auspices of the US Department of Energy.

summarized as follows. A source designed to have a long confinement time for the primary electrons that do most of the ionizing is characterized by high gas efficiency but has a rather poor H^+ species ratio. The poor species ratio is attributed to the fact that under these conditions, the thermal electrons that do most of the dissociation of the gas are confined to less than one-half the source volume; thus, the abundance of molecular gas increases the production of triatomic ions as was observed. Reducing the confinement time for the primary electrons and increasing the active volume for the thermal electrons by increasing the spacing between fewer magnets yielded a modest increase in the species ratio for the monoatomic and diatomic ions and reduced the gas efficiency as calculated. These tests proved that changing the magnet configuration can significantly alter the gas efficiency, power efficiency, and species ratio. This program of ion source optimization is continuing.

75-kV Extractor

The 75-kV single-gap extractor (Fig. 1) was originally designed for 100-kV operation and is described in a previous paper.² Only the electrode gap and electrode contours shown in Fig. 2 were changed when the requirement for injection into the RFQ was reduced to 75 keV. Voltage grading is provided by an adjacent water-resistive divider using the 4 megohm-cm deionized water that also is used to cool the ion source.

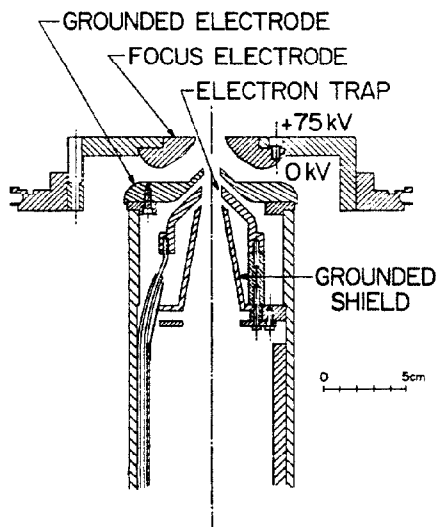

Fig. 2. Electrode geometry of the high perveance 75-kV extractor with spherically convergent beam.

The focus electrode at +75 kV is made of OFHC copper with a 1.95-cm-diam aperture, and the grounded molybdenum electrode has a 1.0-cm-diam aperture. There is a 1.84-cm spacing between apertures. The stainless steel electron trap, normally biased at -2 kV, is spaced 0.20 cm from both the grounded molybdenum electrode and the grounded stainless steel shield that is used to minimize electrical field penetration into the region below. The electron trap lead, insulated by a pyrex tube, passes between the ground electrode support tube and a heavy walled copper sleeve. The latter shields the lead from beam

impingement and the beam from the electric field of the lead that would reduce space-charge neutralization in this region. It is imperative that the electron trap be suitably biased at all times to prevent serious damage to the ion source or focus electrode. On one occasion when the electron trap lead shorted to ground, back-streaming electrons quickly melted a hole through the top of the copper ion source.

Vacuum System

Nearly all of the 0.1 torr ℓ/s hydrogen gas load from the ion source is pumped by a 10 000 ℓ/s oil diffusion pump backed by a 47- ℓ/s two-stage Roots blower and mechanical pump. No oil-contamination problems have been observed on any of the high-voltage insulators in 27 months of operation. Precautions against contamination from the diffusion pump include use of a Freon-refrigerated trap, low vapor pressure polyphenyl ether pumping fluid, and a fast-acting pressure-actuated valve on the foreline. The entire vacuum system, including automatic sequencing, is controlled by an industrial programmable controller.

Test Results

Species-ratio measurements are made by bending the beam with a double-focusing analyzing magnet and calorimetrically measuring the beam current at various locations. A pepper-pot device is available for measuring beam emittance after species separation. However, beam-quality measurements made at that point were dominated by aberrations from the bending magnet. A new bending magnet is now in use and improved pole faces are being designed. An overall hydrogen gas efficiency of 20% to 25% is typical.

One of the requirements for the FMIT ion source was that of having a source that could effectively produce both the monoatomic and diatomic species of a hydrogen isotope. The cusp source has proven to be reasonably adept at this, capable of optimizing on either H^+ or H_2^+ ions with less than 10% H_3^+ production.

The cusp-field source was operated briefly with deuterium rather than hydrogen as the feed gas. This test was run to verify that the source would run stably with deuterium and to quantify the neutron production rate. Neutrons (2.4 MeV) are produced by the D-D fusion between incident ions and deuterium atoms embedded in the copper beam dumps. The source operation was quite stable, with an observed species ratio of 54%, 31%, and 15% of D^+ , D_2^+ and D_3^+ respectively. The observed neutron production rate agreed within 15% with the formula reported by Kim, et al.⁶

$$F = 640 IV^2 \cdot 3^2$$

with I in mA
V in keV
F in neutrons/second .

The results of operation with the new spherical extractor have been extremely satisfying. More than 240 mA of beam current can be extracted at 75 keV. After a 110-cm drift length (no focusing), the visible beam diverged to only 2.3 cm in diameter. The calorimetrically measured current at this position represents about 92% of the total drain from the high-voltage power supply. This small degree of divergence would indicate an effective space-charge neutralization of greater than 99.5% and a normalized emittance no greater than 0.03π mrad-cm.

Acknowledgements

The authors wish to thank all those who participated in setting up the test stand and prototype injector. Special thanks go to T. A. Stephens for much of the detailed design and T. J. Zaugg for his work on the control system.

References

1. D. D. Armstrong, E. A. Meyer, J. D. Schneider and H. L. Rutkowski, "Progress Report on Testing of a 100-kV, 125-mA Deuteron Injector," Proc. 1979 Particle Accelerator Conf., March 12-14, 1979, San Francisco, California, IEEE Trans. on Nucl. Sci., NS-26 (3), 3009.
2. J. D. Schneider, et al., "Development of a High-Current Deuteron Injector for the FMIT Facility," Proc. 1979 Linear Accelerator Conf., September 9-14, 1979, Montauk, New York (Brookhaven Nat. Lab., Upton, NY) BNL-51134, 457.
3. G. R. Brewer, "High Intensity Electron Guns," 23-72, Albert Septier, Ed., Focusing of Charged Particles, (Academic Press, 1967, New York).
4. D. W. Mueller, Los Alamos Nat. Lab., private communication, October 1980.
5. K. Halbach,, Lawrence Berkeley Lab., private communication, June 1979.
6. J. Kim, "Calculations of Neutron Yields from $D(d,n)^3\text{He}$ and $T(d,n)^4\text{He}$ Reactions from Drive-In Targets," The Cyclotron Corp. internal report No. 3014 (September 1976).