



The combination of an active current transformer system (L/R integrator) with the magnetic modulator-demodulator circuit is absolutely essential, even if good high frequency performance is not required in certain applications. The L/R integrator protects the magnetic modulator from transient changes beyond its rather limited linear range, prevents hysteresis errors and rejects modulator noise either superimposed on the error correcting signal or induced in the feedback path, without introducing undesirable phase shift. This permits a high loop gain in the system (in excess of 180 dB at dc) which in turn guarantees high accuracy and linearity as a dc transformer. The ratio between primary beam and secondary feedback current is very accurately defined by  $n$ , the number of feedback turns. In practice, any ratio error at dc is less than 0.1 ppm (part per million).

The overall accuracy as a current measuring device depends ultimately on the stability and precision of the load resistor  $R_L$ . In the actual monitor system this resistor is composed of a number of precision resistors having a combined temperature coefficient of less than  $\pm 1$  ppm/ $^{\circ}$ C. Each individual resistor dissipates less than 60 mW at full scale reading thus limiting the temperature rise.

In order to obtain a high degree of immunity to electromagnetic interference (EMI) in the accelerator environment, all signal and feedback circuits in the actual monitor are strictly symmetrical, for example, there are two feedback windings on each transformer feeding into two load resistors  $R_L$  in a differential mode.

#### The Modulator

The modulator has to provide an excitation current of constant amplitude and frequency (250 Hz) for the modulator cores and the (500 Hz) phase reference signals, for the demodulator. All frequencies are obtained by division from a quartz controlled clock.

A band pass filter and a bridge connected power amplifier provide the sinusoidal drive which is almost free from second harmonic distortion. A control loop maintains a constant peak value of excitation current, independently of load impedance.

#### The Demodulator

The demodulator has to detect phase and amplitude of the 2nd harmonic signal output from the modulator cores. This signal is buried in a much higher level of unwanted frequency components (modulator noise) constituted by the fundamental drive frequency and its harmonics. The origin of this "modulator noise" is the mismatch caused by the residual difference in magnetic parameters of the modulator core pair.

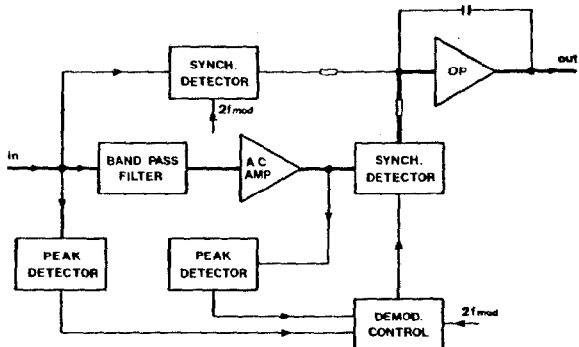

Fig. 2 - Demodulator

Shown in a simplified block diagram, fig. 2, the demodulator has two parallel channels for signal processing. The first is a synchronous detector designed for large amplitude signals and covering the full frequency range. The second channel consists of a selective, narrow band amplifier (band pass filter, ac amp.) followed again by a synchronous detector. Both channels feed into the same summing point of an active integrator with operational amplifier OP.

The narrow band amplifier is optimized for signal levels in the normal, balanced state of operation of the modulator (i.e. no dc error). This provides the high resolution in signal recovery which is necessary for minimum zero drift and low frequency noise in the monitor application. Due to higher gain, only this channel is active under normal operating conditions.

A large dc error (for example immediately after switching on), could easily saturate the high gain channel and may cause a latch-up of the monitor output. The input or output overload states of the amplifier are therefore supervised by two peak detectors which will inhibit the synchronous detector output of this channel via the demodulator control circuit. The first channel, in this case, takes over control and reduces the dc error in a short time to a value low enough to allow the high gain channel to be reactivated again.

#### The magnetic cores

All transformers in the system use the same type of core material - Ultraperm 10\* - a high permeability  $N_i$ - $Fe$  alloy. The core construction is a strip wound toroid (lamination thickness 50 $\mu$ m) embedded without mechanical constraint in a reinforced epoxy case.

Special precautions in the manufacturing process were arranged with the manufacturer (Vacuumschmelze AG, Hanau, W. Germany) to ensure a high product quality, especially with regards to reliable insulation between magnetic layers and a low spread in magnetic parameters.

A computerized test system was made to obtain repeatable precision measurements of relevant magnetic parameters for each core. Data was taken of the static B/H curve and of the permeability  $\mu$  as a function of frequency. Fifty cores of a single production batch were tested in this way and more than 200 data points were stored for each individual core on magnetic tape. From this data identical core pairs were selected for the magnetic modulator application.

#### The ISR Beam Current Monitor

The first application of the combined dc current transformer principle in 1970 was the circulating beam current monitor in the CERN Intersecting Storage Rings (ISR). An improved version, introduced in 1977, has the following performance:

Beam current range	-15A... 0...+80A
Resolution (200ms integration time)	$\pm 10\mu$ A
Linearity	$\pm 0.001\%$
Zero drift (24 h)	$\pm 50\mu$ A
Long term stability (full scale)	$\pm 0.0005\%$
Residual modulator ripple	10mA rms
Frequency range	dc .. 50MHz
Resolution of digital display	7 decimal digits
Free diameter for beam passage	150 mm

\*Trade mark, Vacuumschmelze AG

### High resolution systems

The antiproton projects in CERN required beam monitor systems with still higher resolution. Detailed improvements in modulator and demodulator circuit design, together with better fabrication and selection methods for the modulator cores resulted in a reduced dc drift and low frequency noise figures. As the methods previously described to eliminate residual modulator ripple in the output signal were reaching a practical limit, a second L/R integrator loop was added as shown in Fig. 3.

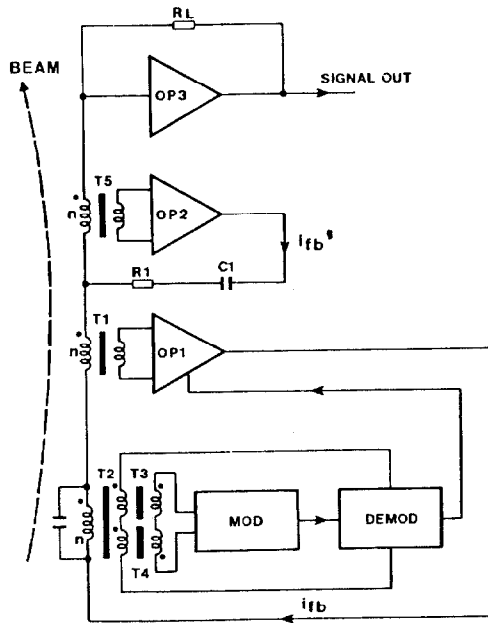

Fig. 3 - High resolution system

Modulator and demodulator, together with the first L/R integrator ( $T_1$ ,  $OP_1$ ) are in the configuration discussed previously. The feedback current now passes through the feedback winding  $n$  of an additional toroid transformer  $T_5$ . Any remaining difference between this current and the effective beam current (for example super-imposed modulator ripple) is sensed by operational amplifier  $OP_2$  and compensated with a current  $i_{fb}'$  via  $R_1$  and  $C_1$ .

Dynamic interaction between both feedback loops is avoided by making the  $R_L$  a virtual zero impedance load ( $R_L$  is in the feedback loop of operational amplifier  $OP_3$ ). The dynamic characteristics of amplifier  $OP_3$  will limit the high frequency response of this system.

The circulating beam current monitors in the CERN antiproton accumulator ring (AA) and in the CERN proton synchrotron (PS) represent this new design and satisfy the following specifications:

Beam Current Range (AA) : -500mA... 0 ... +500mA  
 - 50mA .. 0 ... + 50mA\*

Beam Current Range (PS) : - 2A ... 0 ... + 2A  
 - 20mA .. 0 ... + 20mA\*

\*Change of range obtained by switching the value of Load Resistance  $R_L$

Resolution	(200 ms integration time, any range)	1 $\mu$ A
Linearity		$\pm 0.001\%$
Zero drift (24 h)		$\pm 3\mu$ A
Long term stability (full scale)		$\pm 0.0005\%$ $\pm$ (zero drift)
Residual modulator ripple		5 $\mu$ A rms
Frequency range		dc ... 50 kHz

### Mechanical Design

The ISR and the AA beam current monitor form an integral part of an ultra-high vacuum system. They contain a stainless steel vacuum chamber with a ceramic insulation gap and heating elements for a bake-out at 300°C. Fig. 4 shows the AA beam transformer assembly. The main feature of this construction (Designer : A. Maurer, CERN) is a cantilever design, where all the mechanical supporting functions are linked to one single vacuum flange. This greatly facilitates mechanical and electrical assembly in the laboratory. Concentric on the outside of the cylindrical vacuum chamber (ID = 100 mm) is a heating element, a thermal insulation, and a water-cooled thermal screen to protect the toroids from excessive temperature rise during bake-out. Heat flow between the heated flange and the external support structure is reduced using as an interconnection four stainless steel elements designed to have a low thermal conductance.

The toroids are supported by four aluminium bars which are at the same time an electrical by-pass for wall currents in the vacuum chamber system. Circular, metalised discs of fibreglass reinforced epoxy board provide individually screened compartments for each core. The electrical connections pass through thin-walled brass tubes which are soldered to the metallisation of the screens and link the windings to two external connector boxes.

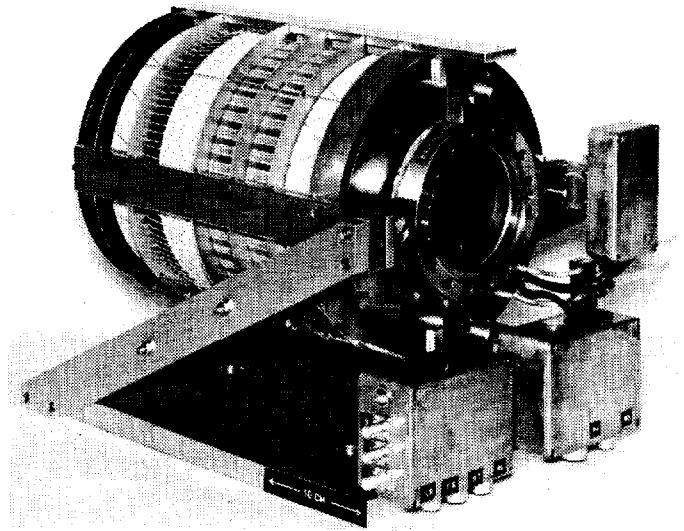

Fig. 4 - Transformer Assembly (magnetic shield removed)

### References

1. J.B. Sharp, "The Induction Type Beam Current Monitor for the PS" CERN MPS-CO/62-15.
2. K. Unser, "The Circulating Beam Current Monitor" CERN-MPS-CO/68-1.
3. K. Unser, "Beam Current Transformer with DC to 300 MHz Range", IEEE Trans. Nucl. Sci., June 1969.