

BETATRON TUNE MEASUREMENT AT THE ARGONNE RAPID CYCLING SYNCHROTRON\*

Antanas V. Rauchas, Franklin R. Brumwell, Yanglai Cho, Walter S. Czyz,  
Gary R. Gunderson, Martin J. Knott, Dale E. Suddeth, and Gerald J. Volk  
Argonne National Laboratory  
Argonne, Illinois 60439

Introduction

In the past, betatron tune measurements at the Rapid Cycling Synchrotron (RCS) were made using a spectrum analyzer for betatron frequency analysis and one of the extraction kicker magnets to induce the coherent betatron motion. This method had several severe limitations: poor signal-to-noise ratio, inability to extract the beam after the measurement and dependence on the horizontal "kick" coupling into the vertical plane for vertical tune measurements. A new system is presently being constructed which will eliminate these problems. The beam will be kicked by independent horizontal and vertical ferrite "pinger" magnets. The beam position data will be digitized and then analyzed by an array-processing computer using the Fast Fourier Transform (FFT). The control system will allow for additional improvements.

Background

When the RCS was commissioned in 1977,<sup>1</sup> the betatron tunes were measured to check the theoretical values, as well as to calibrate the effects of the correction quadrupole and sextupole magnets. This method used the RF knockout methods that had previously been used successfully on the Zero Gradient Synchrotron (ZGS).<sup>2</sup> The beam was driven by a frequency-sweeping RF power amplifier feeding an electrode. The beam motion was detected by monitoring the fast beam position with a spectrum analyzer. As the frequency was swept through the knockout frequency, this frequency was detected on the beam motion. However, this system was quite ineffective. The short acceleration cycle of the RCS meant that the rotational frequency changed rapidly and, therefore, so did the knockout frequency. Because of the poor signal-to-noise ratio of the fast position system, small oscillations were not easily detected and the beam had to be driven at the knockout frequency for a period of  $\approx 1$  ms. This required very precise adjustment of the frequency sweep and was difficult to achieve and reproduce.

The RF knockout method was quickly rejected and replaced by the "pinger" method. This method used one of the extraction kicker magnets to induce a small kick to the beam. This displacement decayed back to equilibrium at the betatron frequency. The fast beam position signal and spectrum analyzer were again used to detect the motion. However, this method also had its shortcomings. The initial betatron motion was larger than by the RF knockout method, but decayed rapidly and, because of the poor sensitivity of the fast position system, was not detectable after  $\sim 100$   $\mu$ s, the threshold of the spectrum analyzer's sensitivity. Since one of the extraction kicker magnets was used to induce the betatron oscillations, the beam could not be extracted from the RCS and was therefore lost in the accelerator and activated the accelerator components. Vertical betatron tunes were able to be measured only because the horizontal kick was coupling into the vertical plane because of midplane distortion.

The "pinger" method was used for most of the tune measurements on the RCS and, although limited in accuracy, providing betatron tune resolution of less than

$\pm 0.002$ , the method was adequate to adjust the correction quadrupoles and sextupoles for reasonably efficient operation. But as operating beam intensities and related instabilities increased<sup>3</sup> and betatron tune control capabilities were expanded,<sup>4</sup> the need for an improved betatron tune measurement system with resolution better than  $\pm 0.001$  became obvious.

System Description

Past experience had indicated that the existing beam position system was inadequate to provide the necessary resolution for betatron tune measurements. The beam position system was rebuilt for this as well as other reasons.<sup>5</sup> Beam motion would be induced by separate, programmable horizontal and vertical "pinger" magnets, and the new fast beam position signal from any of the six electrodes could be used to detect the betatron motion. The turn-to-turn beam position signal from one of the electrodes would be integrated by a high speed integrator and digitized by a digitizing oscilloscope. The data then would be transferred to an array-processing computer to be analyzed using an FFT. This FFT would yield the fractional component of the tune ( $0.0 \leq \nu' < 0.5$ ). The present working point of the RCS is limited to  $2.0 < \nu < 2.5$ , so the FFT is adequate at the present time without any additional measurements. If the working point is ever changed, the integer part of the tune would be measured by using the six fast position signals for a single turn. A block diagram of the system is shown in Fig. 1.

"Pinger" Magnets

Although horizontal and vertical "pinger" magnets were planned, budgetary and manpower limitations forced the delay of their implementation. For the present, the extraction kicker will be used again to induce the horizontal betatron motion. No direct means to induce the vertical motion will be provided but, again, orbit imperfections are expected to couple the horizontal motion into the vertical plane. The "pinger" magnet system will be built and installed as soon as possible.

As with any accelerator, straight section space is always at a premium. The room for "pinger" magnets did not exist until the extraction kicker magnet system was redesigned from two magnets in separate straight sections, into a single magnet.<sup>6</sup> This opened up approximately 70 cm for the "pinger" system. A specific design is not complete, but some conceptual thoughts are available.

Each "pinger" should be capable of inducing an orbit distortion of approximately 1 to 2 mm at any energy from the 50 MeV injection energy, to the extraction energy of 500 MeV. With the lattice of the RCS,<sup>7</sup> this distortion requires a kick  $\approx 1.0$  mrad. A 30 cm magnet would require a magnetic field of 35 gauss at injection and 120 gauss at full energy to produce the kick. The design of the original extraction kicker magnet system described in Ref. 8 could be scaled down considerably to satisfy these requirements with a minimum amount of problems since the system was designed for a maximum of 3600 A and the "pinger" requirements are less than 300 A. The only added complexity to the designed system would be the addition of a programmable power supply to dynamically vary the "pinger" field as a function of momentum.

\*Work supported by the U. S. Department of Energy.

## Data Acquisition

The betatron beam motion is detected by the fast beam position system (Ref. 5). This system provides dc restored and amplified outputs from each plate of the six horizontal and six vertical electrodes. Only the signal from a single plate is required to measure the tune, and the signal can be selected by the operator on a cable patch panel. Use of a single plate assures that the signal is unipolar and therefore simplifies the processing.

The measurement is initiated at an operator selectable time of the RCS acceleration cycle. The signal is integrated by two high-speed integrators operating alternately on a turn-to-turn basis for up to 1000 turns. Their outputs are selectively sampled by an Analog Device HTS-0025 high-speed sample and hold. This signal, in turn, is sampled by a Nicolet Explorer Digital Oscilloscope. The Nicolet, in the external trigger mode, can digitize data at a rate of up to 20 MHz and has a digital memory of 4096 eight-bit words. The timing for the integrators, sample and hold, and the Nicolet sample is derived from either of two sources: the beam signal itself, or the RF accelerating system's master oscillator.

## Data Analysis

The computer used is a Data General Eclipse AP-130 (identical to the Eclipse S-130 but with an array processor built in). It is capable of a wide variety of array-oriented operations including several signal-processing functions. Of interest to this task is the FFT which the AP-130 can perform in 9 ms on an array of 1000 data points. A dedicated high-speed memory, built-in sine-cosine tables, and pipelined arithmetic processor are part of the design.

The computer's main task is to function as the control and monitoring computer for the RCS. It performs this function in "foreground" while, during available time, it is able to perform a variety of off-line and on-line tasks, such as this tune calculation activity, in "background." It is equipped with the usual complement of peripheral devices such as disk memory, but pertinent to this task is a graphics output capability which allows it to present the machine tune results in graphic form.

The interface to the Nicolet digital oscilloscope consists of a 12-bit parallel, bidirectional bus and control signals. At the computer end, the data is handled by direct memory access so that a 1000-point array can be transferred in 0.8 ms without program intervention. This two-way link allows the computer to bring in waveforms, as well as to output processed results. The oscilloscope front-panel control settings can also be imbedded in the incoming data so that the program can compensate for changes in display settings.

The array processor is used to float and scale the input data and to transfer it to the high-speed memory. The FFT is then performed and the major frequency component information extracted with other array instructions so that no individual data point handling is necessary. Output results will initially be presented in numeric form. This will be followed by graphic presentation with the tune data plotted against computer-measured independent parameters, such as position and energy, under control of the operator. The computation procedure and speeds described above should enable a tune point to be calculated in about 11 ms. The ultimate procedure will be to have the computer control the independent parameters, thus allowing the entire tune function to be obtained without operator assistance.

## Conclusion

Preliminary tests of the new system have been completed using the extraction kicker as a "pinger" magnet. Data has been gathered, digitized, and the FFT calculated. The results are within expectations.

The new system expands the tune measurement capabilities tremendously. The computer allows for data processing which improves signal-to-noise ratio and further increases resolution. The system will also lend itself to study beam motion other than betatron.

## References

1. A. V. Rauchas, F. R. Brumwell, G. J. Volk, "Commissioning of the Argonne Intense Pulsed Neutron Source Accelerator," *IEEE Transactions on Nuclear Science* Vol. NS-26, No. 3, pp. 3006-3008 (June 1979).

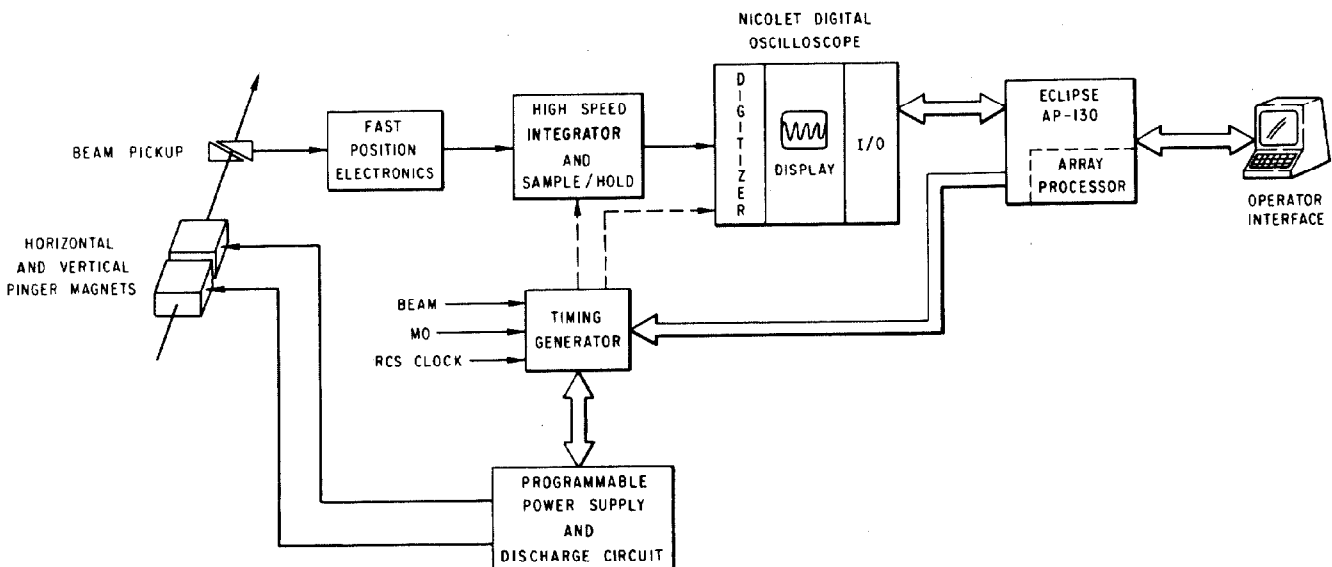

Fig. 1 Tune Measurement System Block Diagram

2. C. W. Potts, "An Instrument for Measuring Betatron Resonant Frequencies," IEEE Transactions on Nuclear Science Vol. NS-18, No. 3, pp. 382-386 (June 1971).
3. C. W. Potts et al., "Status Report on the Rapid Cycling Synchrotron" (proceedings of this conference).
4. C. W. Potts et al., "Tune Control Improvements on the Rapid Cycling Synchrotron" (proceedings of this conference).
5. A. V. Rauchas et al., "Beam Position Measurement System at the Argonne Rapid Cycling Synchrotron" (proceedings of this conference).
6. D. E. Suddeth and G. J. Volk, "Rapid Cycling Synchrotron (RCS) Single Stage Kicker Magnet," Presented 1980 14th Pulse Power Modulator Symposium, Electron Device Society of IEEE, Orlando, Florida, June 3-5, 1980.
7. E. Crosbie et al., "The Design of the Zero Gradient Synchrotron Booster II Lattice," IEEE Transactions on Nuclear Science Vol. NS-22, No. 3, pp. 1919-1921 (June 1975).
8. D. E. Suddeth and G. J. Volk, "Intense Pulsed Neutron Source (IPNS-I) Accelerator 500 MeV Fast Kicker," IEEE Transactions on Nuclear Science Vol. NS-26, No. 3, pp. 3024-3025 (June 1979).