

Andrew Browman
Los Alamos National Laboratory
P. O. Box 1663
Los Alamos, NM 87545

Summary

The average power in the LAMPF primary beam is now approximately 450 kW. At these power levels errant beams can quickly destroy accelerator or experimental area beam line components, while the long-term deposition of even a small fraction ($\ll 1\%$) of the beam energy in unintended locations can result in activation levels too high for "hands-on" maintenance. This paper describes the present status of the hardware beam transmission monitor, which is one of several evolving redundant protection systems. Beam currents are measured by toroids located at various places along the accelerator and in the experimental areas. Losses are determined by subtracting the signals from appropriate toroids. Long-term (\sim month) stabilities are sufficient to enable loss tolerances of $\pm 0.5 \mu\text{A}$ to be maintained with $500\text{-}\mu\text{A}$ average currents, while short-term (\sim hour) fluctuations are an order of magnitude smaller. The absolute accuracy of the beam measurements is believed to be $\pm 0.5\%$. These systems have provided reliable protection with little maintenance required for the past few years.

Introduction

Modern accelerators can produce beams capable of melting accelerator or beam-line components as well as quickly activating components to levels much too high for "hands-on" maintenance. Although remote maintenance of accelerator and experimental areas is possible the added cost and time for this type of operation makes it unattractive except where absolutely necessary (e.g. target cells, beam dumps, etc.). At LAMPF, the activation constraint implies average beam current losses of $< 10 \text{ nA/m}$ of accelerator length; the beams presently in use can cause damage in $< 100 \mu\text{s}$.¹

The ideal protection system would be sensitive enough to keep activation at low levels, fast enough to prevent burnup, and usable for both local and large area protection. The systems described here satisfy all the criteria above except local protection. It is not feasible, for example, to have enough current monitors to detect whether a given amount of beam is lost on a target or on nearby collimators. For this kind of protection different types of detectors are more suitable.

The present systems provide continuous transmission monitoring and protection from 70 MeV in the Alvarez Linac to the high-current beam stop in Area A by subtracting the beam currents (measured by toroids) at the entrance and exit of various sections along the accelerator. The transmission monitor (TM) system was installed in 1977 along the linac and extended in 1980 to include the switchyard and high-current experimental areas. Redundancy is provided by photomultiplier/scintillator detectors along the accelerator and by many different devices such as guard rings, beam-on-target monitors, etc., in the experimental areas.¹

*Work performed under the auspices of the U. S. Department of Energy.

Description and Performance

The toroids used to measure beam currents in the TM systems are of various sizes depending on their location. In addition, many toroids in the experimental area are in high radiation fields which change the permeability of the magnetic material used and hence the inductance. (Decreases of more than a factor of 10 in inductance have been observed in some cases after several years of operation.) Since a very precise subtraction of toroids is desired to provide activation protection, the time constants of the toroids must either be extremely long or very well matched.

Figure 1 is a simplified schematic of the preamplifier developed to minimize the effects of different input resistances (due mainly to varying cable lengths) and different inductances for the toroids used in the TM. In Fig. 1, R_{in} represents the total input resistance (including toroid winding resistance, cable resistance, op-amp input resistance, etc.). When the resistor values are chosen so that $R_{fb}/R_{in} = R_3/R_4$ then the effective resistance (R_{eff}) seen by the inductor is \sim zero and the time constant, L/R_{eff} , is very long. (This circuit creates a negative resistance equal in value to R_{in} and adds it in series with R_{in} to produce a very small R_{eff} .) The circuit is unstable so the dc restore circuit is used to hold the output at zero volts except when the beam is present. The speed of the zeroing circuitry is adjusted to minimize the effects of the inevitable 60-Hz noise picked up by the toroid. When the resistor ratio R_3/R_4 is adjusted by hand, perfect cancellation of R_{in} can be achieved but such circuits require periodic adjustment. The most satisfactory performance has been obtained by designing a circuit

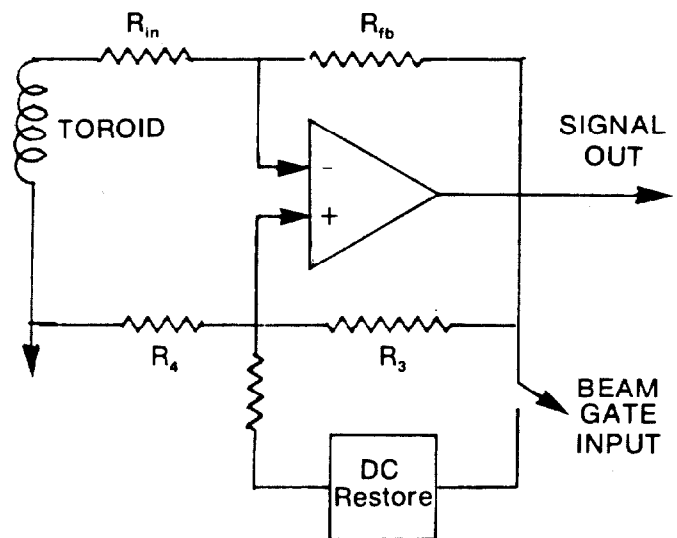

Fig. 1. Simplified toroid preamplifier schematic.

which continuously measures R_{in} and makes an adjustment to R_4 , which is a FET chosen to have the correct range of on resistance. Reduction of R_{in} by 50-100 times is typically achieved by these circuits leading to L/R_{eff} of order 5 s for the 100 turn toroids in use at LAMPF. High frequency response of the circuits is limited to about 15 kHz as a compromise between noise and the response time needed to avoid possible damage caused by large losses.

The signals from the preamplifiers upstream (I_{in}) and downstream (I_{out}) of the protected region are sent via shielded, twisted-pair cables to the central control room where they are subtracted to obtain the difference current, I_{diff} .

$$I_{diff} = I_{out} - fI_{in}$$

In this equation, f is a number between 0 and 1 that represents the "expected loss" in the region. For example, in the accelerator $f = 1.0$ but across a thick production target in the experimental area f might be as low as 0.8.

Figure 2 is a block diagram of the type of measurements made. H^- beams go down Line X and are measured by LXCMI, H^+ beams are time-shared between Line D and Line A and are measured by LDCMO and LACM3, respectively. In this case, then, the transmission measurement made is:

$$I_{diff} = (I_{LACM3} + I_{LDCMO} + I_{LXCMI}) - fI_{LACM2}$$

where the sign of an H^- current is negative and an H^+ current is positive. (Note that a loss of H^- current is the same as a gain of H^+ current and that therefore cancelling losses in the two beams are not detected by the TM.) Figure 3 is a chart recorder measurement of the short-term stability of the switchyard transmission measurements while the average current in the accelerator was about 500 μA . The "spikes" going down near zero μA represents times the beam was off. During a typical two-month running period, the tolerance on the switchyard loss is set at $\pm 0.5 \mu A$ to avoid spurious trips. This tolerance is typical of the tolerances needed along the accelerator. Loss tolerances in the experimental area must be much larger ($\sim 5 \mu A$)

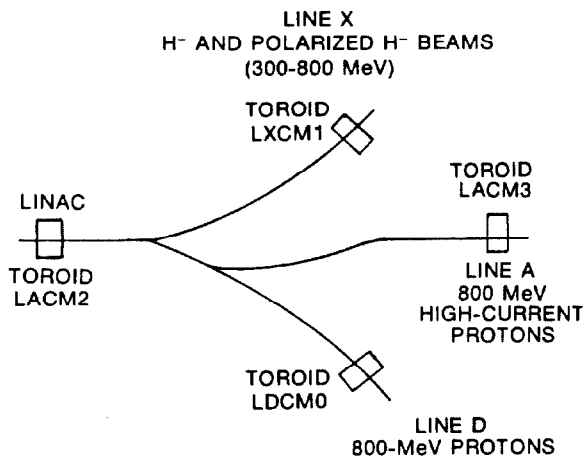

Fig. 2. Schematic diagram of switchyard showing switchyard toroids used in transmission protect system.

SWITCHYARD LOSS

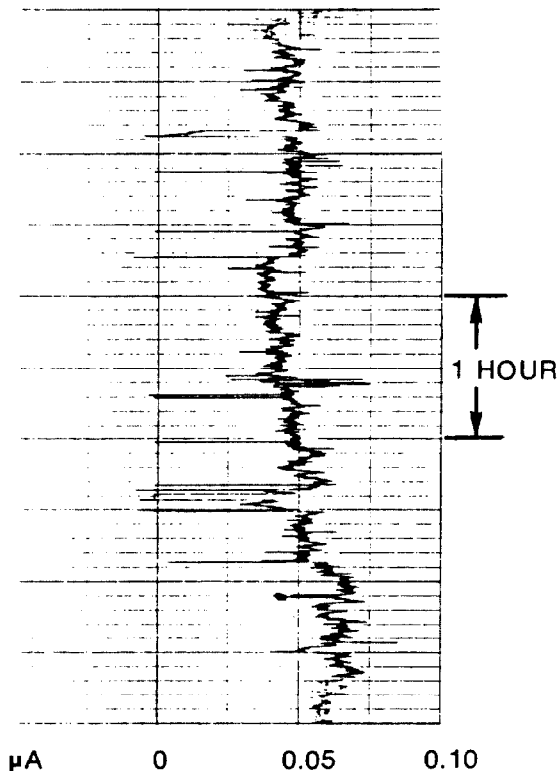

Fig. 3 Short-term transmission error signal in switchyard with approximately 500- μA -average current in linac.

due to target imperfections and beam motions causing "tails" to miss the targets.

The preamplifiers are located as close as practical to their toroids but all the rest of the TM system is in a single rack in the control room. Calibrated adjustments for the expected loss and tolerance are provided as well as visual indication of trips and diagnostic facilities. The entire experimental area TM is contained in one standard size NIM bin. Further, more detailed, information about the TM system (including schematics) can be found in Ref. 2.

Conclusion

The beam transmission monitor systems used at LAMPF have proven reliable, easy to maintain, and a valuable source of protection for the past several years. They are used to reduce activation levels as well as to provide fast protection against burnout in case of massive spills along the accelerator and in the experimental areas.

Acknowledgment

The original preamplifier used an RC circuit matched to cancel the L/R of the coil. I am indebted to Jan Studebaker for the negative resistance concept which considerably simplifies the input stage.

References

1. R. J. Macek, E. W. Hoffman, and O. B. van Dyck, "LAMPF Primary Beam Line Protection System," IEEE Trans. on Nuc. Sci., NS-26, No. 3 (June 1979).
2. A. A. Browman and D. G. Poelakker, "Experimental Area Hardware Transmission Monitor," unpublished MP Division report, February 15, 1980.