

NEGATIVE HYDROGEN ION INJECTION INTO THE ZERO GRADIENT SYNCHROTRON*

C. W. Potts
Argonne National Laboratory
Argonne, Illinois 60439

Summary

In October 1976 the Zero Gradient Synchrotron (ZGS) became the first high energy proton synchrotron to use charge exchange injection in routine operations. Conversion to H^- injection has been very successful, yielding record high beam intensities within the first month of use and normal (>90%) operating efficiencies within the second month. This report discusses briefly the history of H^- at the ZGS, the hardware uniquely associated with charge exchange injection and our operational experience during the first two months of H^- injection.

Introduction

The concept of charge exchange injection has been around for some time,¹ but the decision in 1969 by ANL to develop a small booster synchrotron for the ZGS using H^- injection² was the first application to an operational high energy synchrotron. The ZGS booster is a small aperture, small radius machine which requires an injector beam brightness much higher than that of the ZGS injector linac. This very serious problem is solved trivially (assuming an adequate H^- source and stripper) by charge exchange injection. The practical need of having an H^- beam available for the development of this booster dictated, however, that the ZGS must be converted to H^- injection also since there is only one injector available for both machines. There was also the additional motive that stemmed from the fact that the ZGS linac could accelerate only 40 mA and so more 50 MeV beam could be injected into the ZGS using a weaker H^- beam than the 40 mA H^+ beam.

The value of charge exchange injection is that it frees us from the limitations expressed by the Liouville's theorem. In the ZGS the physical manifestation of this newly found freedom is the replacement of the inflector magnet by a very thin stripping foil. Since the injected beam can recirculate through this foil, the circulating beam intensity, I_c , is dependent only upon the intensity of the injected I_{inj} beam, I_{inj} , and the injection time, i. e.,

$$I_c \propto I_{inj} \Delta R / \dot{B} \quad (1)$$

where ΔR is the radial aperture of the machine and \dot{B} is the rate of rise of the magnetic field at injection. It therefore becomes theoretically possible to fill any machine to its space charge limit regardless of the injected beam intensity by simply providing adequate injection time. There are, of course, some practical limitations associated with emittance growth due to scattering in the foil, foil life time, linac pulse length

restrictions and the betatron tune and tune control at extreme values of \dot{B} . These last two limitations are unique to each machine and for the ZGS are about 600 μs and 7 kG/s. Actually lower \dot{B} values can be used if a low \dot{B} is used for the entire cycle; however, this leads to a reduced repetition rate and increased power dissipation in the magnet and RF.

That charge exchange injection really works was demonstrated at ANL in 1972³ when brightness multiplication of over 100 was obtained using the Cornell 2.2 GeV electron synchrotron (installed at ANL after being decommissioned at Cornell). Subsequent demonstrations were made using the ZGS in 1974.

An operational H^- ion source and stripper were installed in September 1976 and after one week of machine tests and tune up, charge exchange injection became operational in the ZGS. The injector beam is a reasonably square 550 μs , 6.5 mA pulse. The foil is a 3200 A strip of poly-paraxylene. We started off with a \dot{B} of 5 kG/s, but shifted to 8 kG/s when we had difficulty with the betatron tune at the \dot{B} transition, i. e., where \dot{B} is raised from its injection value to its acceleration value (~ 18 kG/s). At 8 kG/s there is still adequate radial acceptance for a 550 μs pulse. Also, by spreading the 550 μs pulse over more of the radial aperture the charge density was reduced. Under these conditions, we promptly set new intensity records and ran into serious space charge problems. Using the programmable pole face windings⁴ of the ZGS to compensate for space charge effects, we accelerated a peak beam of 6.3×10^{12} protons per pulse (p/p) and had a monthly average of 5.0×10^{12} p/p compared to previous records of 5.4×10^{12} p/p and 4.3×10^{12} p/p respectively. We could capture over 10^{13} , but could carry it only for a few ms. The tune condition that gave the peak accelerated beam gave only 8.5×10^{12} p/p at capture. In the second month of operations we raised \dot{B} to 10 kG/s to reduce further the injection charge density, but were not as successful as at 8 kG/s. Although there may have been other "non-physics" related reasons for this poorer performance at 10 kG/s, the loss of effective RF voltage at the higher \dot{B} could have been a contributing factor. In the March 1977 run, we will use 7 kG/s and dilute the charge density by increasing the betatron amplitude.

A few of the subsystems peculiar to H^- operation will now be briefly discussed.

Ion Source

The H^- ion source from which the ZGS started⁶ operation in October is a tandem acceleration source in which positive ions are extracted from a hydrogen plasma at ground potential and accelerated to 20 keV. The accelerated beam enters into a charge exchange cell (Fig. 1) where it is converted into an equilibrium mixture of positive ions, negative ions and energetic neutrals. The particles are created as a result of

*Work supported by the U. S. Energy Research and Development Administration.

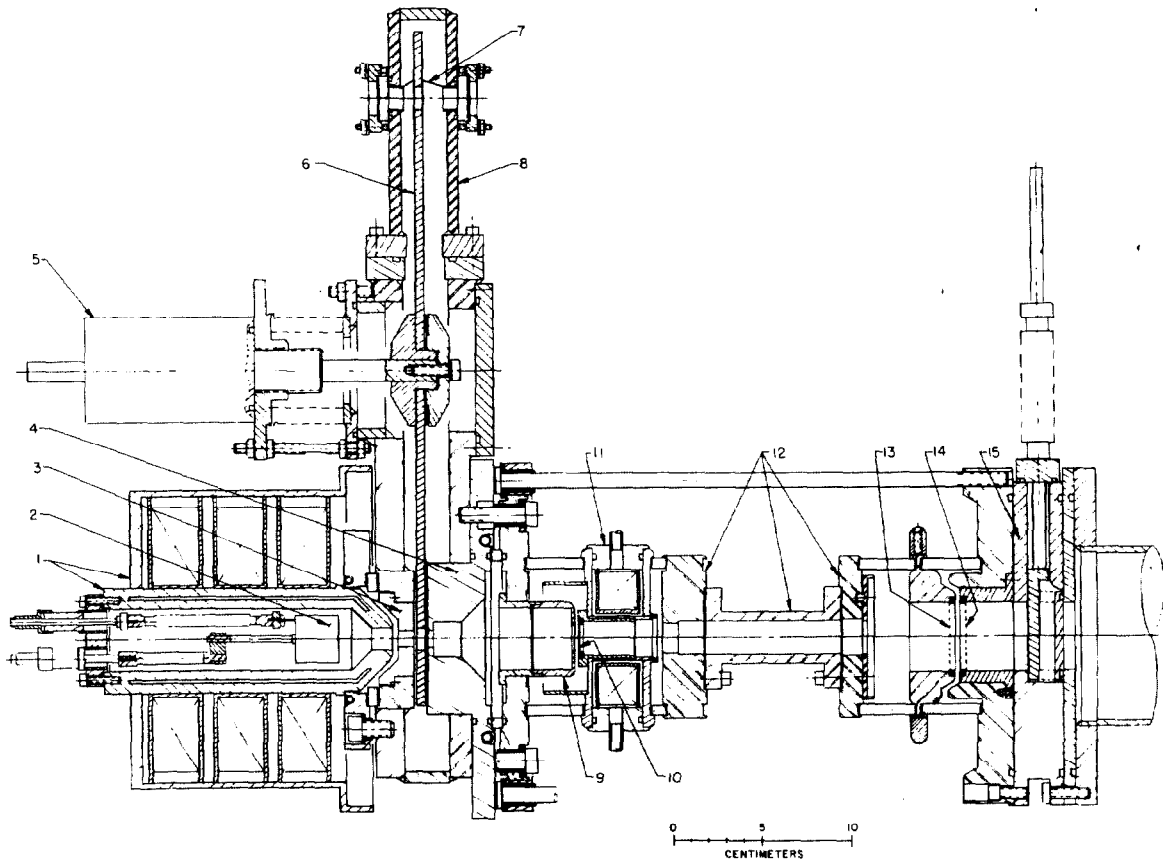

Fig. 1.

Operational 1 Hz H^- Source Assembly. (1) Intermediate Electrode and Flux Return. (2) Cathode. (3) Anode I. (4) Anode II. (5) Ferrofluidic Drive Unit. (6) 30 Hz Gas Shutter. (7) Brushes. (8) Valve Housing. (9) Source Grid. (10) Extractor Grid. (11) Field Shaping Magnet (M-2). (12) Charge Exchange Cell. (13) Suppressor Grid. (14) Grounded Grid. (15) Isolation Valve.

collision with the target gas which consists of the H_2 outflow from the plasma source. Gas flow into the source is continuous, but the outflow is pulsed at a 30 Hz rate by a rotating gas shutter valve. The space charge of the positive ion beam entering the charge exchange cell is neutralized by free electrons produced by ionizing collisions of beam particles with target gas molecules. H^- ions emerge from the charge exchange cell and are accelerated through a second gap. Some heavy negative ions are also created due to impurities in the arc plasma.

The source now in use is an improved version of the source used in the first test in 1974. In the interim, a continuous program of modifications have been carried out. Many trade-offs between grid transparency and grid life were explored. A significant improvement was made in the summer of 1975 by modifying the source anode to reduce interception of plasma and thus increasing the initial beam diameter. This change increased source current to 33 mA from 15 mA. About 70% of this was full energy H^- . As installed in the 750 keV terminal, with its slight aperture restriction and the necessary electron traps, the source has delivered 27 mA to the linac. As Fig. 2

shows, a nicely shaped 500 μs wide pulse with a 7 mA peak is carried through the linac to 50 MeV.

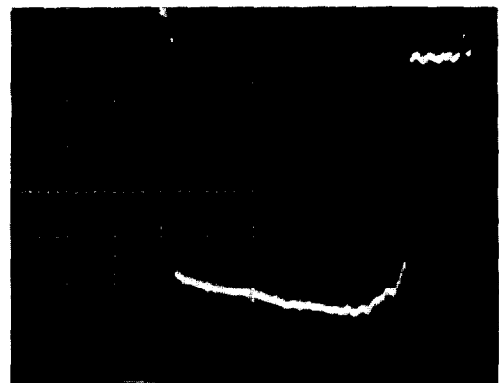

Fig. 2.
7 mA 50 MeV H^- pulse delivered to ZGS.
Time base 100 $\mu s/cm$.

The operational problems with the source have been less than expected. In the October run about twenty-four hours of unscheduled downtime was caused by the H⁻ source. Improved high voltage noise immunity in the arc modulator and extractor power supplies reduced this downtime to less than three hours in the January 1977 run. The current pulse shape and amplitude remains quite stable once the appropriate parameters are set.

The scheduled downtime, however, is increased with the H⁻ source. A rather heavy gas load of about 0.13 Torr-l/s is pumped with a titanium sublimation pumping system. The titanium slugs must be replaced every two weeks. This necessitates a twenty-four hour shutdown.

Foils and Foil Handling

The problem of foil making and remote exchange of broken foils has now become a new concern of accelerator operations.

The poly-paraxylene foils are made from a commercially available powder. This powder is vaporized, then vacuum deposited on a 6 in x 7 in glass plate. This plate must be very clean and treated with mold release before foil deposition. The foil maker watches its formation through a viewing port and determines the approximate thickness by the color of its reflected light. Finished foils are later checked with an interferometer for exact thickness. The "eyeball" treatment is usually correct to within 10%.

Removing the foils from the glass plate without tearing them is a tricky business. A high humidity atmosphere helps to make this procedure easier. Sometimes condensed breath on the foils or use of an ion gun helps by removing the static charge. The foils are attached to the foil holder with distilled water as the adhesive. A small amount of cleaning detergent is usually added to the water. Foils 2000 A

thick can be made and mounted with about a 50% success rate while the success rate for 3000 A foils rises to 90%.

A schematic of the foil exchange mechanism is shown in Fig. 3. The foil exchange process is controlled from the main control room and viewed via television. The exchange sequence begins with the new foil magazine moving into the center of the vacuum chamber from its retracted position. When it reaches the center it signals the arm to swing in an arc as shown. The arm is mounted on a spring loaded eccentric in such a way that when its circular motion is rigidly stopped by hitting the foil magazine carriage the spring tension is overcome and the eccentric revolves. The eccentric action creates a motion which is nearly perpendicular to the circular path it has previously followed. As the arm continues to move along this new axis, a clever arrangement of pins, springs and inclined planes disengages a set of pawls and drops the spent foil into a retaining basket. As the linear motion of the arm continues, a new holder is captured in the pawls and a signal from a limit switch is sent to reverse the arm drive motor and bring the arm with a new foil back to its operating position. Of course, the magazine is withdrawn from the beam path also. The time required to exchange a foil and resume operation is about five minutes. Figs. 4, 5 and 6 show various views of the foil and foil changing mechanism.

The foil holder is a 4-3/4 in x 6 in aluminum fork as shown in the inset of Fig. 3. The foil is 2 in wide while the beam at this point has a half width of about 3/4 in. When bombarded with beam the tension in the foil increases substantially. We have found it increases foil life to avoid rigid suspension at both ends. A 1 g captured weight is attached to the bottom of the foil, thus tending to keep tension constant and stretching to a minimum. Most of our operation has been with either 2600 A or 3200 A foils and there is no noticeable difference in lifetime between the two

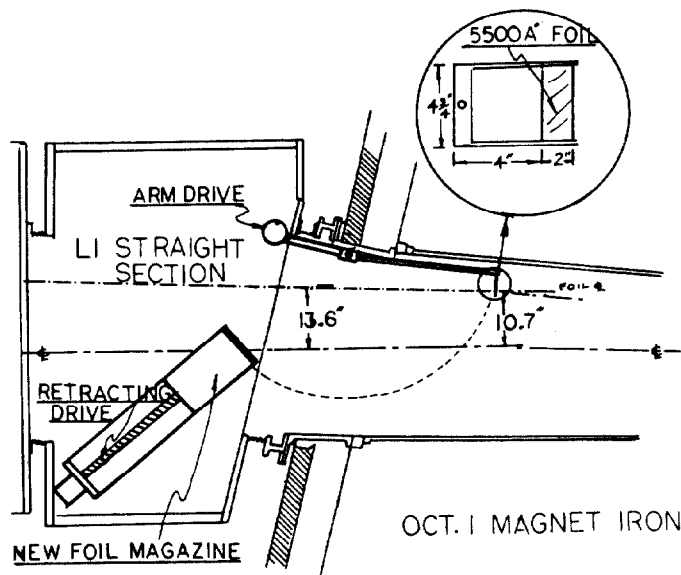

Fig. 3. Schematic of Stripping Foil Holder and Automatic Changing System.

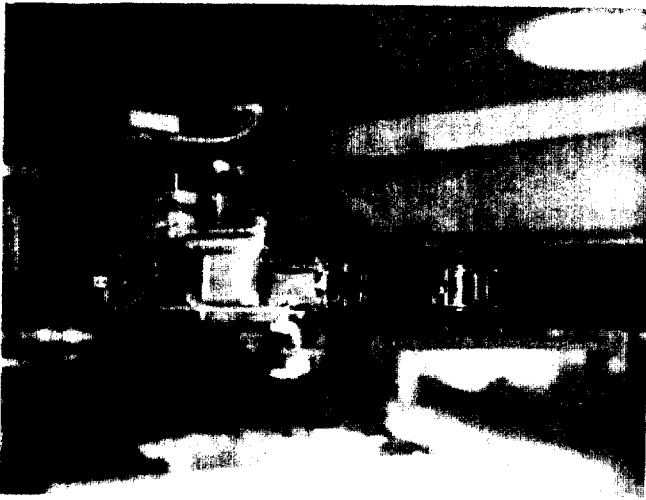

Fig. 4.
Foil in operating position.



Fig. 5.
Foil cartridge in exchange position.
Foil holding arm moving.

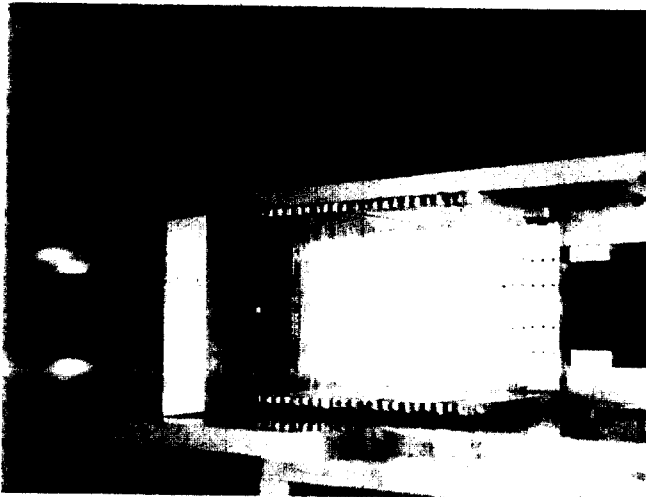

Fig. 6.
Close up of foils in exchange cartridge.

foils. The factors that affect foil life are clearly pulse repetition rate and injection \dot{B} . In October we operated with a 3.1 s repetition rate and a \dot{B} of 8 kG/s. The foil life averaged about five hours. In January, with a repetition rate of 4.2 s and a \dot{B} of 10 kG/s, the average life was twelve hours. Obviously, the trends are in the right direction but linear scaling doesn't apply. Other factors such as extraction orbits may have played a part. Beam handling during the acceleration cycle must be done very carefully because it is possible to break a foil in a few pulses when it is hit by high energy beam. Beam left over at the end of the machine flattop must not be allowed to recirculate through the foils.

A machine study on foil thickness versus stripping efficiency and multiple scattering was carried out. Foils of 1800, 2600, 3200, 4800, 7500 and 14,000 A were used in the study. The stripping studies yield useful data which indicated 100% stripping at 4800 A, 95% at 3200 A, 92% at 2600 A and 80% at 1800 A.

Machine studies of beam growth as a function of foil thickness have been attempted. The results were inconclusive. Acceptable operation has been carried out with foils as thick as 7500 A. Of course, the ZGS has a rather generous 5 in vertical aperture. The machine space charge limitation also tends to mask scattering effects. Since foil thickness is not tightly coupled to either foil life or acceleration efficiency, 3200 A was chosen as the standard thickness. This thickness has a high production yield and can be handled successfully during installation in the accelerator.

Conclusion

H^- operation has become the standard high intensity mode at the ZGS. Experimental trade-offs between injection time and space charge limitations are being explored during HEP operation in an attempt to maximize intensity. The potential benefits from H^- operation will vary with each accelerator. All gain

from filling phase space better, but a machine with a 40 mA limited linac such as the ZGS gets more benefit than most.

Acknowledgements

Some thirty people deserve mention for their contribution to this effort. Some have submitted publications on the new subsystems. Since the list is so lengthy, we will just thank them all as a group. They know who they are!

References

1. G. I. Dimov, et al., USSR National Conference on Particle Accelerators, Moscow, USSR, October 9-16, 1968.
 2. R. L. Martin, "The Argonne Zero Gradient Synchrotron Booster," IEEE Transactions on Nuclear Science (June, 1971), Vol. NS-18, No. 3, p. 953.
 3. J. D. Simpson, "Operating Results From the ANL Booster," IEEE Transactions on Nuclear Science (June, 1973), Vol. NS-20, No. 3, p. 198.
 4. E. Crosbie, et al., "Injection and Acceleration of Protons in the ZGS by Stripping H^- Ions," IEEE Transactions on Nuclear Science (June, 1975), Vol. NS-22, No. 3, p. 1056.
 5. A. V. Rauchas and A. J. Wright, "Betatron Tune Profile Control in the Zero Gradient Synchrotron Using the Main Magnet Pole Face Windings," to be published in IEEE Transactions on Nuclear Science this conference.
 6. J. A. Fasolo, " H^- Source Development at Argonne," to be published in IEEE Transactions on Nuclear Science this conference.
-