



# The ESS Accelerator Moving into Construction

J. G. Weisend II  
For the ACCSYS Collaboration  
October 2016

# Introduction to ESS



The goal of ESS is to provide a spallation based neutron source significantly more powerful than existing sources: 30 - 100 times brighter than ILL and 5 times more powerful than SNS

This facility will enable neutron based research in a wide range of fields including: materials science, condensed matter and biomedical studies

# ESS Is a European Project

## Financing includes cash and deliverables



### Host Countries of Sweden and Denmark

47,5% Construction

15% Operations

**In-kind Deliverables** ~ 3%

**Cash Investment** ~ 97%

### Non Host Member Countries

52,5% Construction

85% Operations

**In-kind Deliverables** ~ 70%

**Cash Investment** ~ 30%

Total Project: 1843 Million Euros

Accelerator: 519 Million Euros

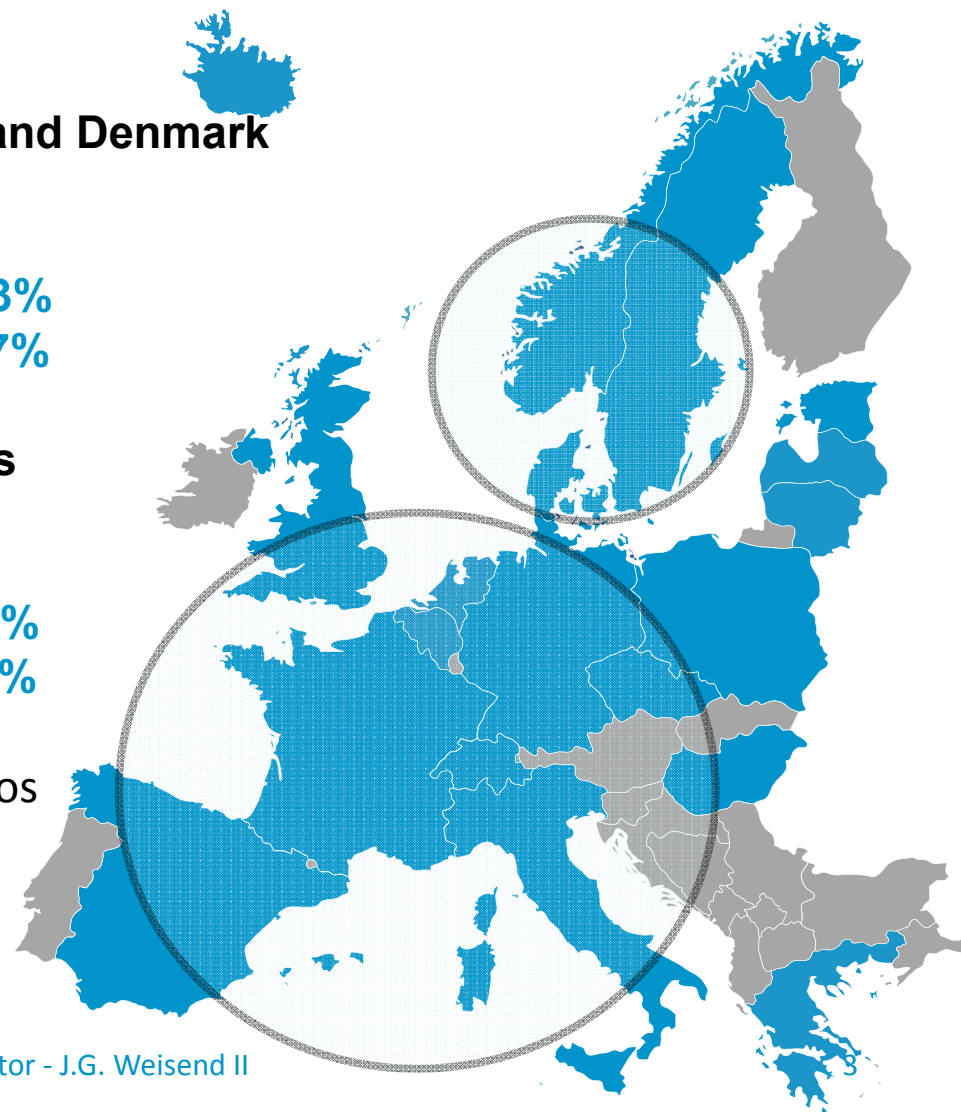

# ESS Overview



The ESS Accelerator - J.G. Weisend II

## Design Drivers:

High Average Beam Power

5 MW

High Peak Beam Power

125 MW

High Availability

> 95%

## Key parameters:

-2.86 ms pulses

-2 GeV

-62.5 mA

-14 Hz

-Protons (H<sup>+</sup>)

ESS is a pulsed facility the  
beam is “on” only 4 %

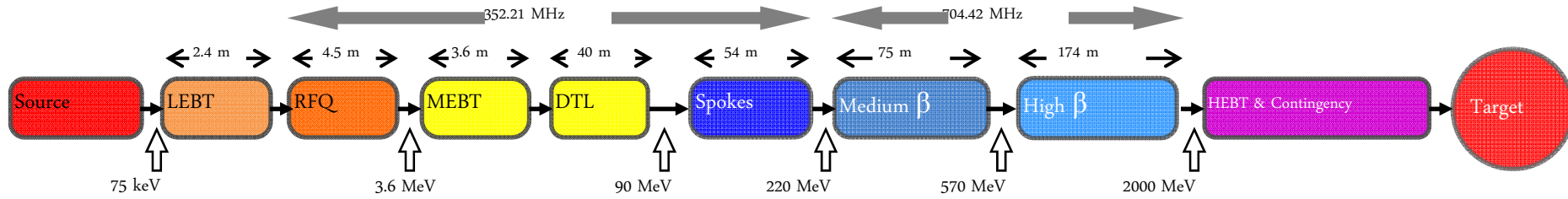

	Energy (MeV)	No. of Modules	No. of Cavities	$\beta_g$	Temp (K)	Cryo Length (m)
Source	0.075	1	0	—	~300	—
LEBT	0.075	—	0	—	~300	—
RFQ	3.6	1	1	—	~300	—
MEBT	3.6	—	3	—	~300	—
DTL	90	5	5	—	~300	—
Spoke	220	13	2 (2S) $\times$ 13	$0.5 \beta_{opt}$	~2	4.14
Medium $\beta$	570	9	4 (6C) $\times$ 9	0.67	~2	8.28
High $\beta$	2000	21	4 (5C) $\times$ 21	0.86	~2	8.28
HEBT	2000	—	0	—	~300	—

# More than 50% of the Accelerator Project, including almost 100% of the Linac components are provided by Partner Institutions

## In-kind (main contributions)

ATOMKI (RF-LPS)  
CEA (RFQ, SRF, Diagn)  
CNRS (SRF, Cryo)  
Cockcroft Inst (Diagn)  
Daresbury Lab (SRF, Vacuum)  
Elettra (RF, Magn, PS, Diagn)  
ESS-Bilbao (MEBT, RF)  
GSI (Diagn, Vacuum, Cryo)  
Huddersfield Univ (RF distrib)  
IFJ PAN (Installations)  
INFN Catania (Source, LEBT)  
INFN Legnaro (DTL)  
INFN Milan (SRF)

NCBJ (LLRF)  
Tallinn UT (RF)  
TU Lodz (LLRF)  
Univ Oslo (Diagn)  
Warsaw UT (LLRF)  
Wroclaw UT (Cryo)

## Paid contracts

Aarhus Univ (Beam del)  
DESY (Diagn)  
Lund Univ (LLRF, RF)  
PSI (Diagn)  
Uppsala Univ (Tests)

- Not yet signed
- Contract signed
- HoA signed
- IKC signed

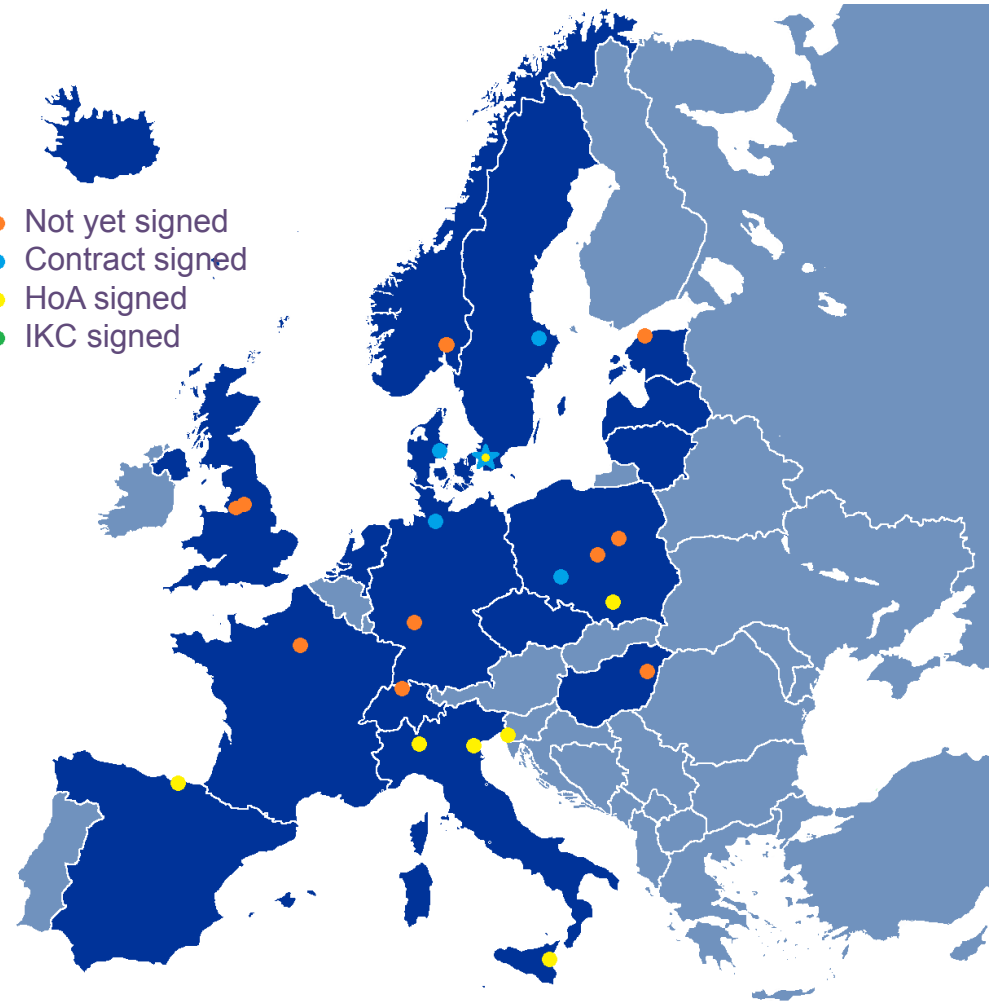

# The First Ion Source and LEBT is currently under construction & Commissioning at INFN Catania

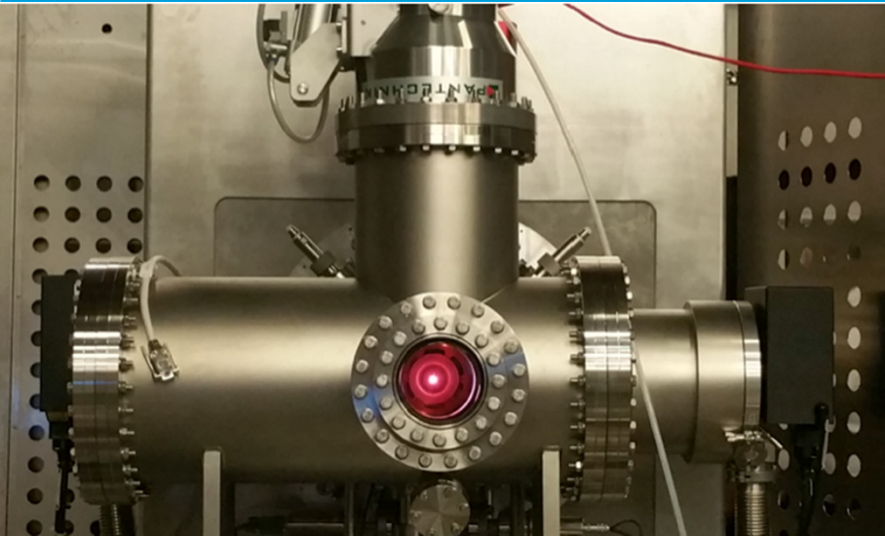

First Plasma in Ion Source

Installation in Catania  
LEBT including beam  
instrumentation and controls  
to be added  
Installation in ESS Tunnel : Q4  
2017



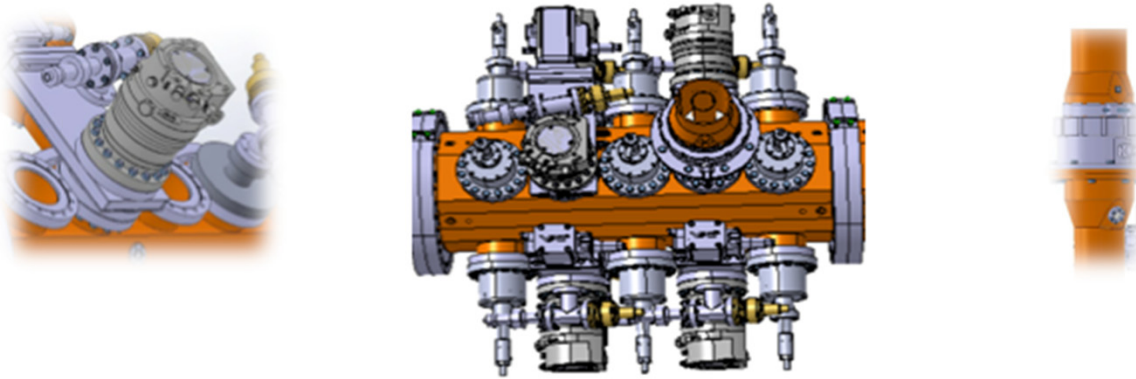

*RFQ mechanical assemblies showing the possibility to add gate valves if desired on the left, one fully equipped segment with gate valves (center) and the power coupler (right).*



Tuner  
prototype  
**under testing**

Critical Design Review has been completed  
Copper has been procured and HIP and is now at machining vendor

# MEBT September 2016 Status

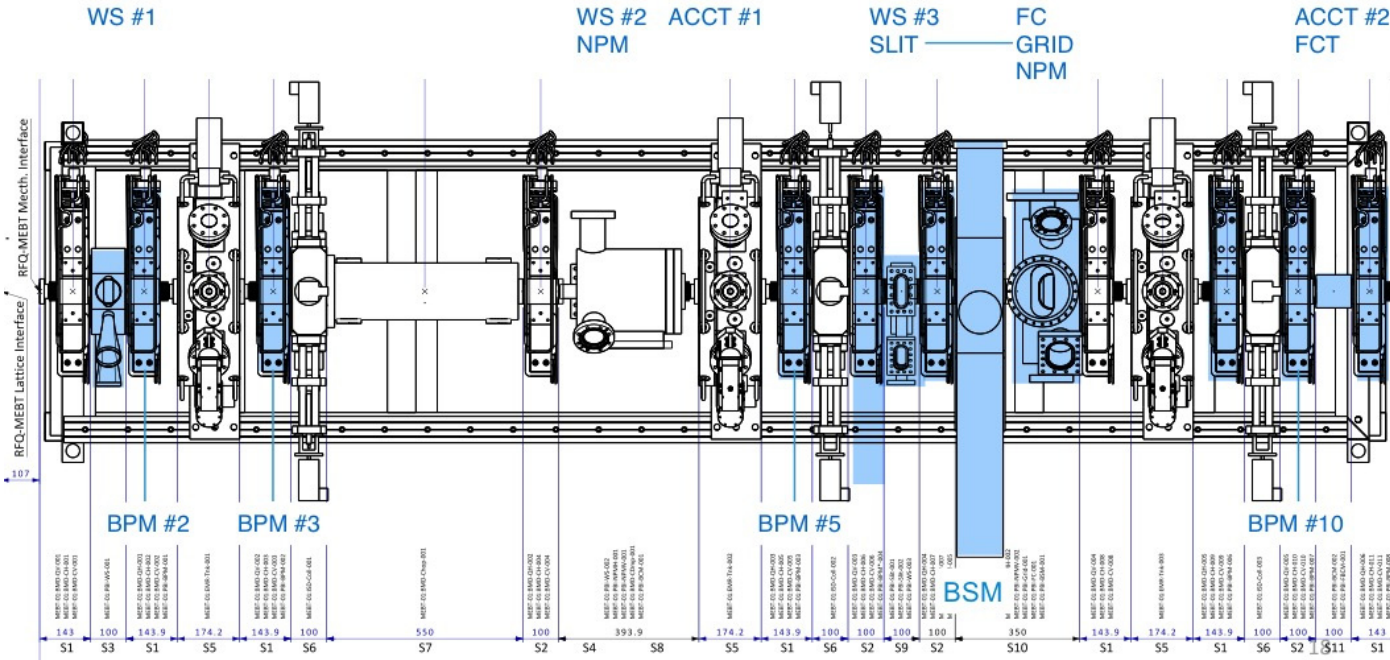

- Mechanical integration completed
- Prototype magnets and bunchers produced
- Diagnostics PDR completed

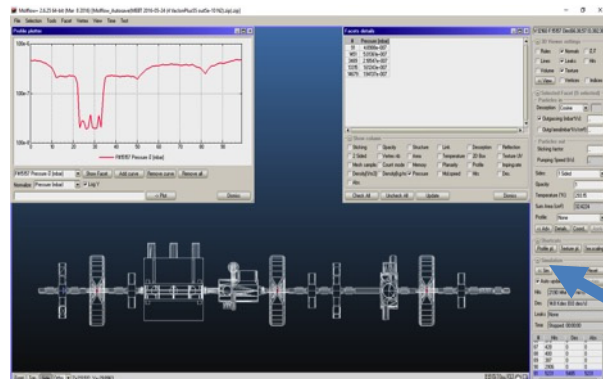

Integrated CDR planned for Q1 2017

Vacuum simulations

# DTL: provided by INFN Legnaro

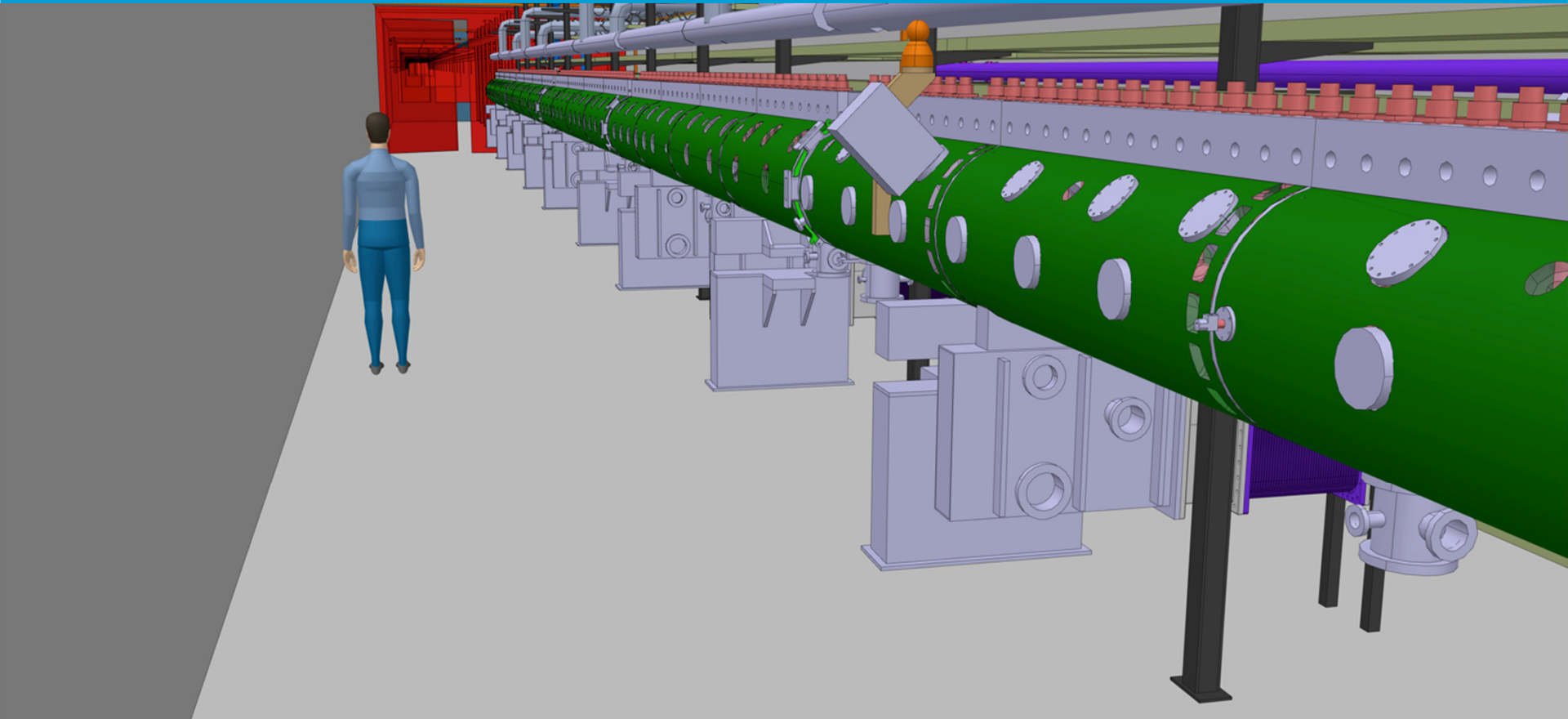



Prototype BPM parts

Prototype connector body

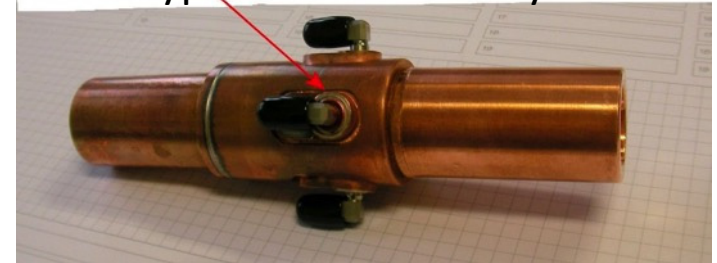

## Progress on:

- Finalizing DTL req. & interfaces
- TA contract (signed by INFN)
- Detailed dwg for DTL tanks
- Tendering for tank material started
- Tendering for machining started (#3 & #4)
- Prototyping on BPM's
- Thermal cycling

# ESS Double-Spoke prototype cavities

## ZA-01 Romea, ZA-02 Giulietta & SD-01 Germaine

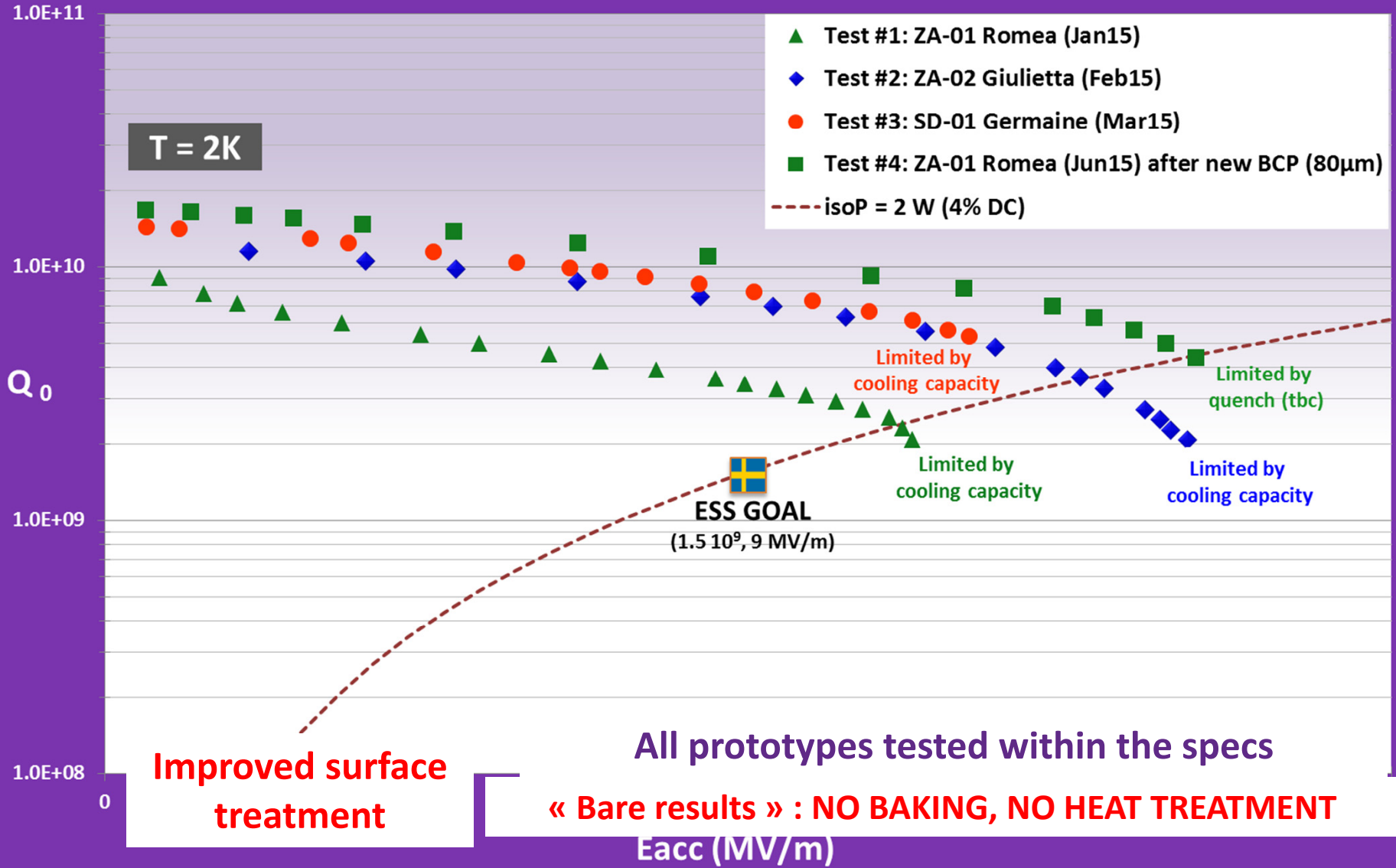

# ESS Double-Spoke prototype cavities

## ZA-01 Romea, ZA-02 Giulietta & SD-01 Germaine

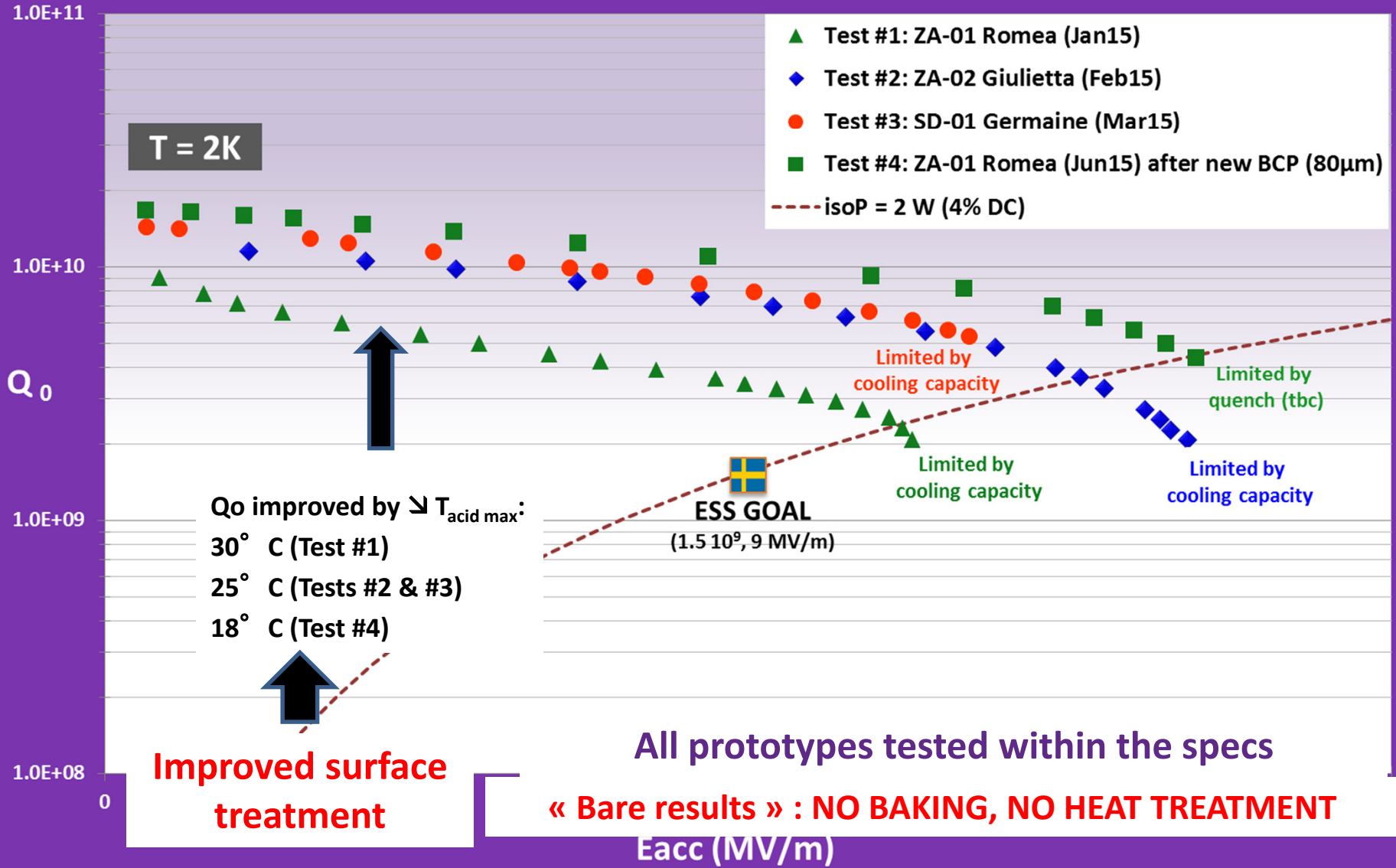

# Spoke cryomodules: design & prototype fabrication: IPNO & CEA Saclay

## Prototype cryomodule fabrication: all “big” parts fabricated

**Spoke cryomodule vacuum vessel:**  
Fabrication achieved (FAT done)

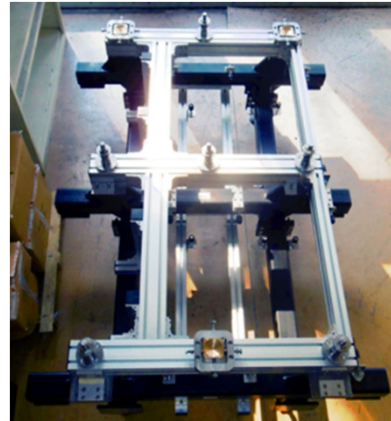

**Cryomodule support**

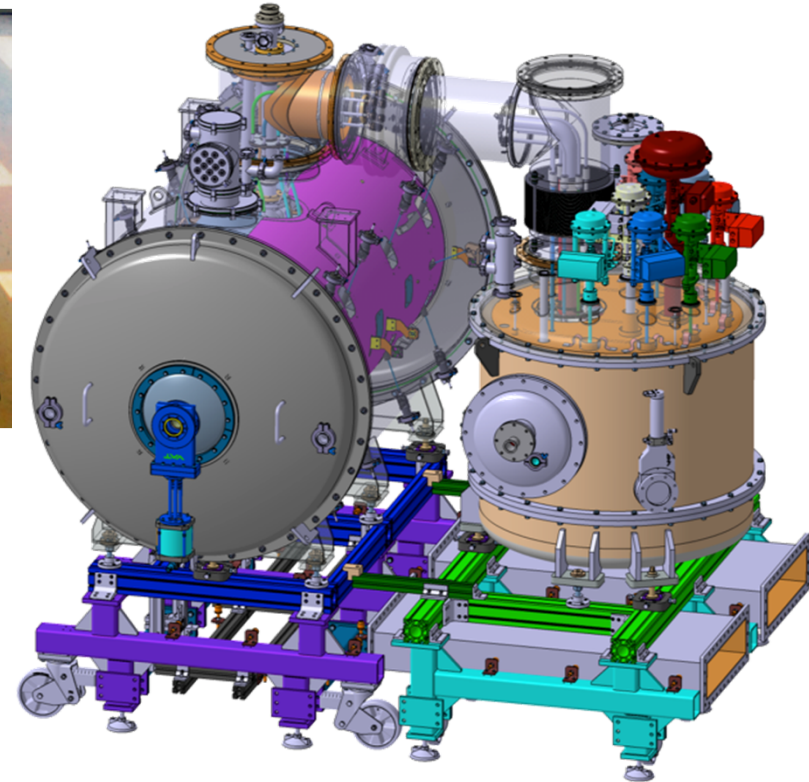

**Spoke valve box:** detailed design in progress, procurement for heat exchanger and cryo valves is ongoing



**Cold/warm transition**



**Inter-cavity  
belows**



**Gate valves**

# Medium Beta Cavities – First Prototype

Vertical test ESS medium beta prototype  
25th July 2016

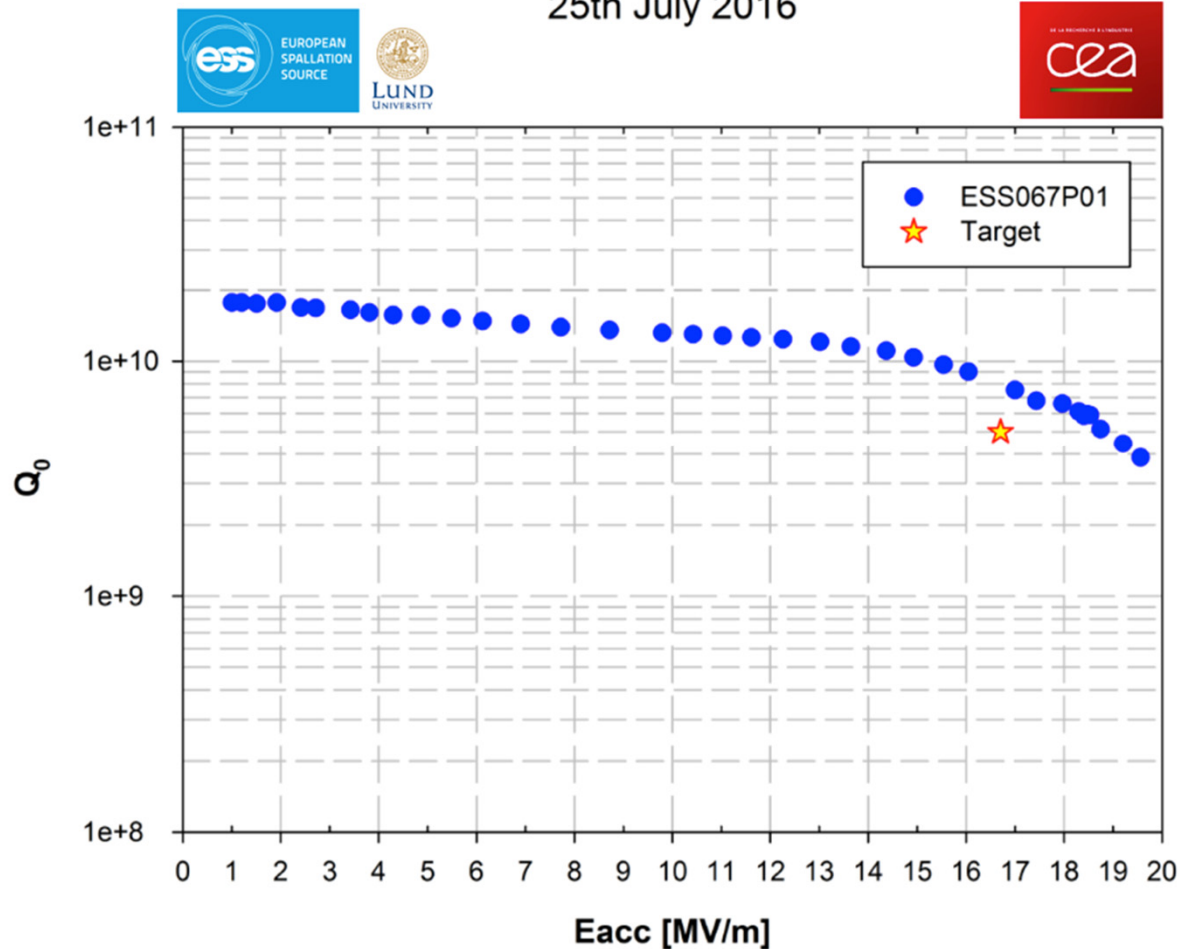

# High Beta Cavities – Before Heat Treatment

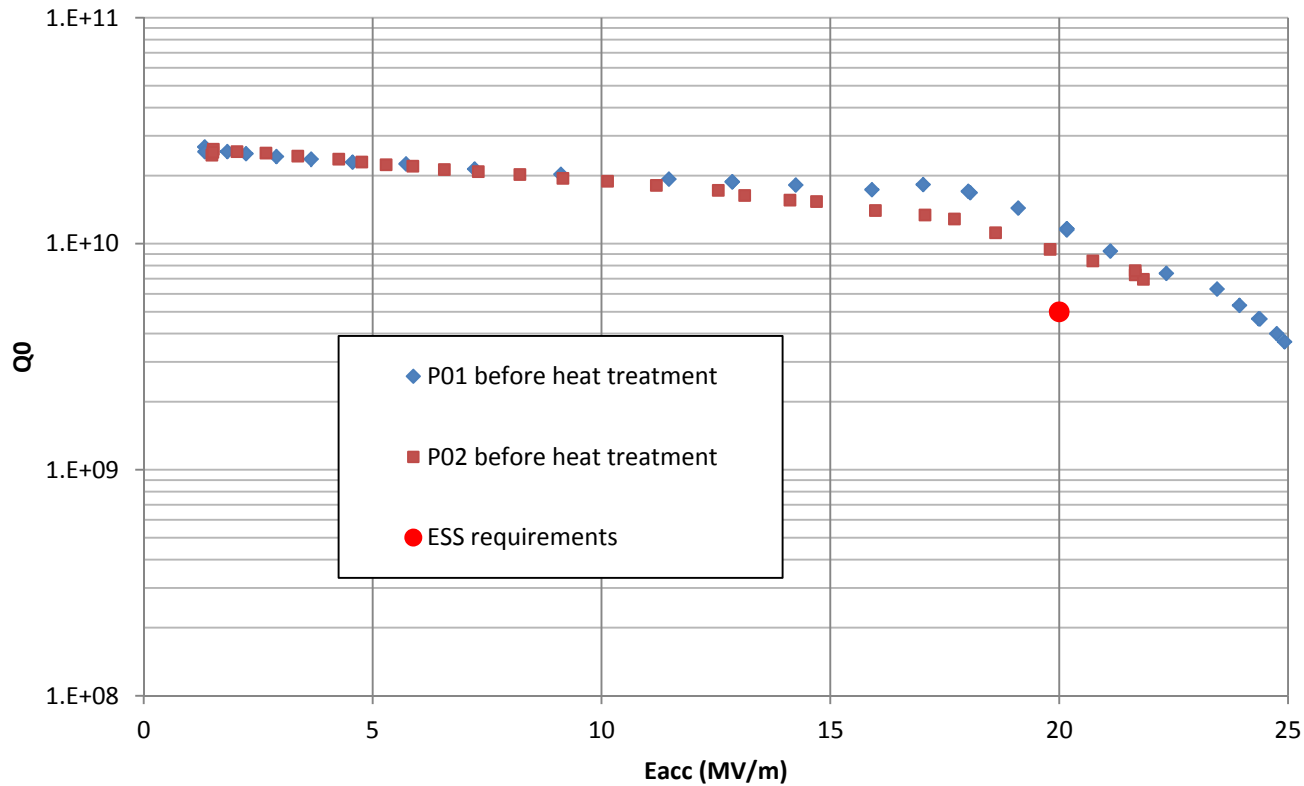

# Elliptical Cavity Cryomodules

- Similar to CEBAF/SNS cryomodule concept with 4 cavities per cryomodule
- Common design for medium (6 cells) and high beta (5 cells) cavities

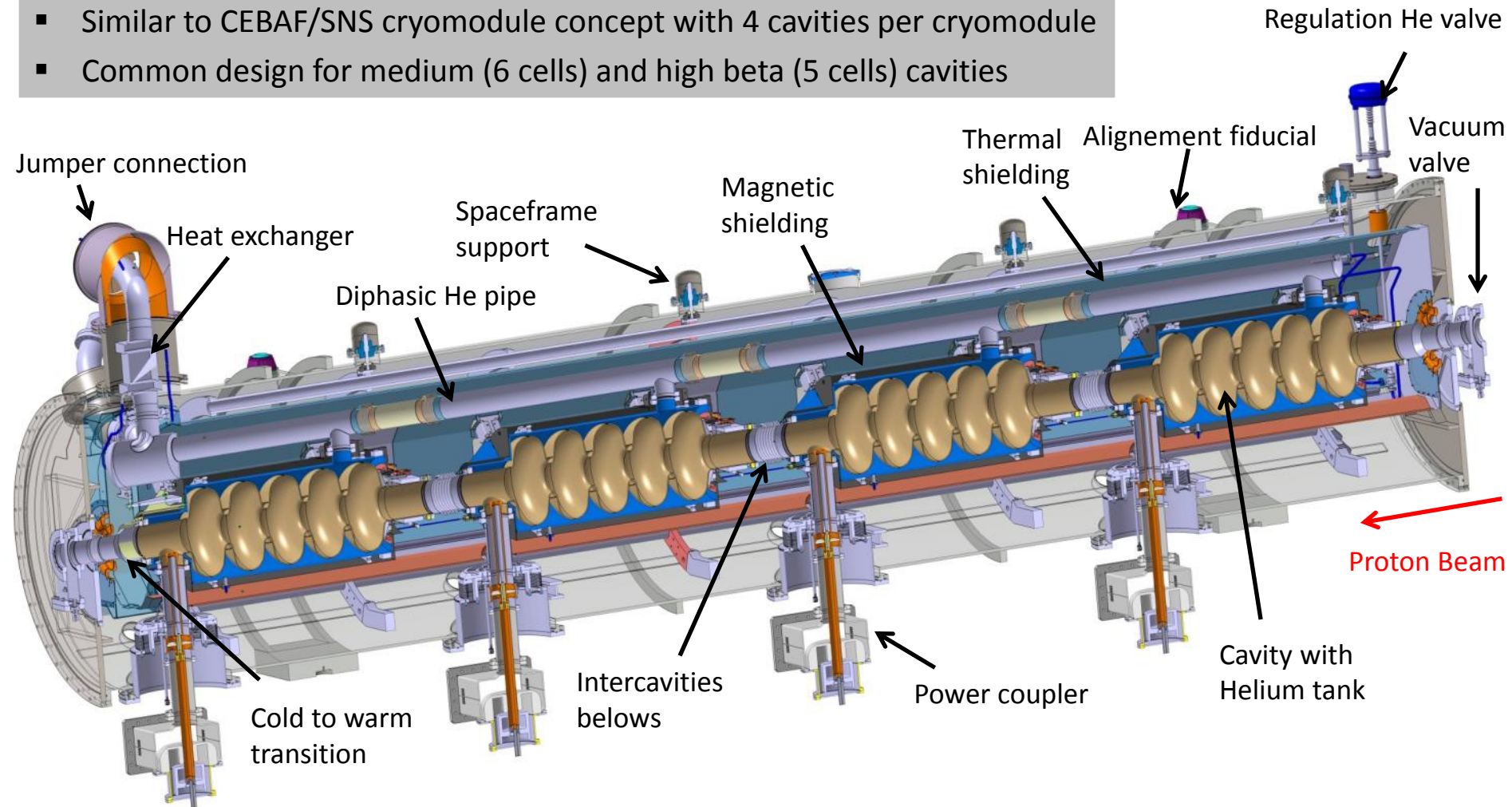

# M-ECCTD cryostat components, toolings and assembly infrastructure



Production of the main components and the toolings is in progress

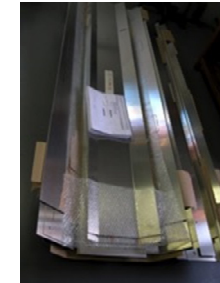
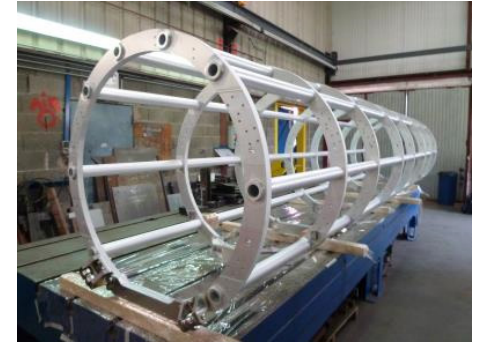

.....



The ESS BÔTH is being equipped (cryomodule assembling outside the cleanroom)



The vacuum chamber, space frame should be installed with assembling toolings before the end of february

Alignment of the rails used for the insertion of the cavity string inside the vacuum tank.



# Linac Warm Unit

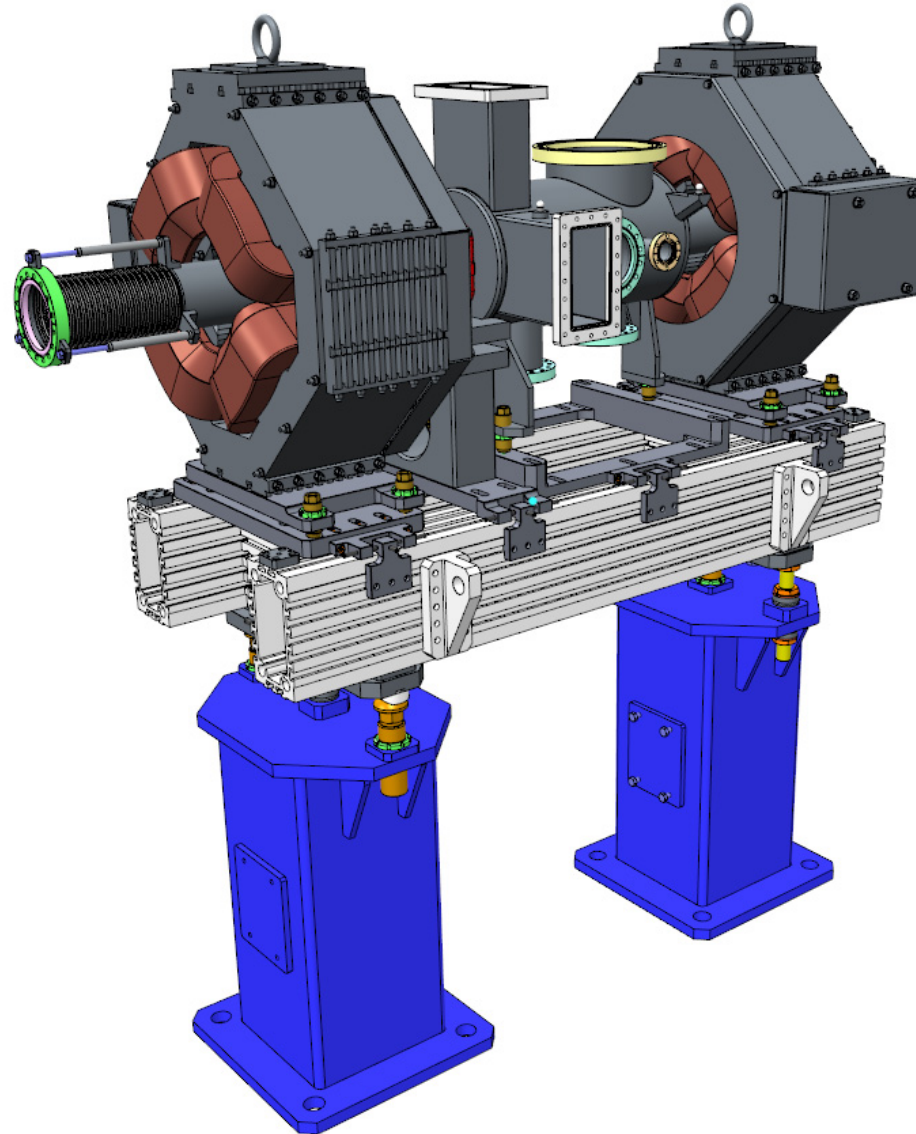

# First LWU Prototype Delivered to ESS



# Beam Delivery System: Aarhus University

Profile monitor (wires + non-invasive)

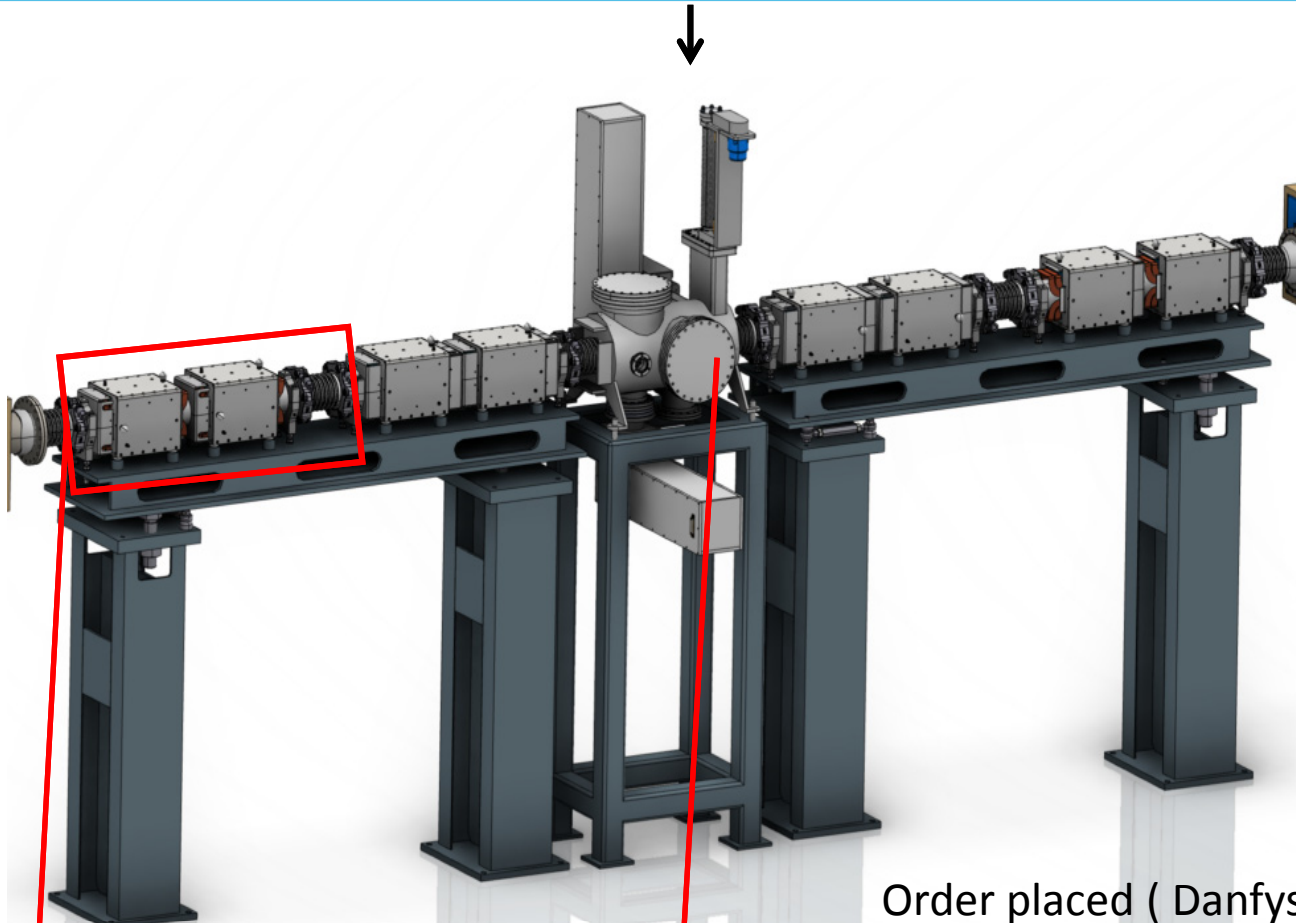

Order placed ( Danfysik)  
and first article construction underway

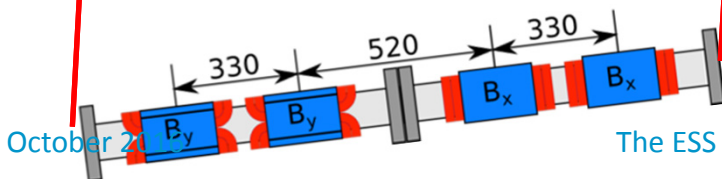

# Accelerator Cryplant (Linde)

*Detailed Solid Model of Cold Box - Final CDR held in September 2016*

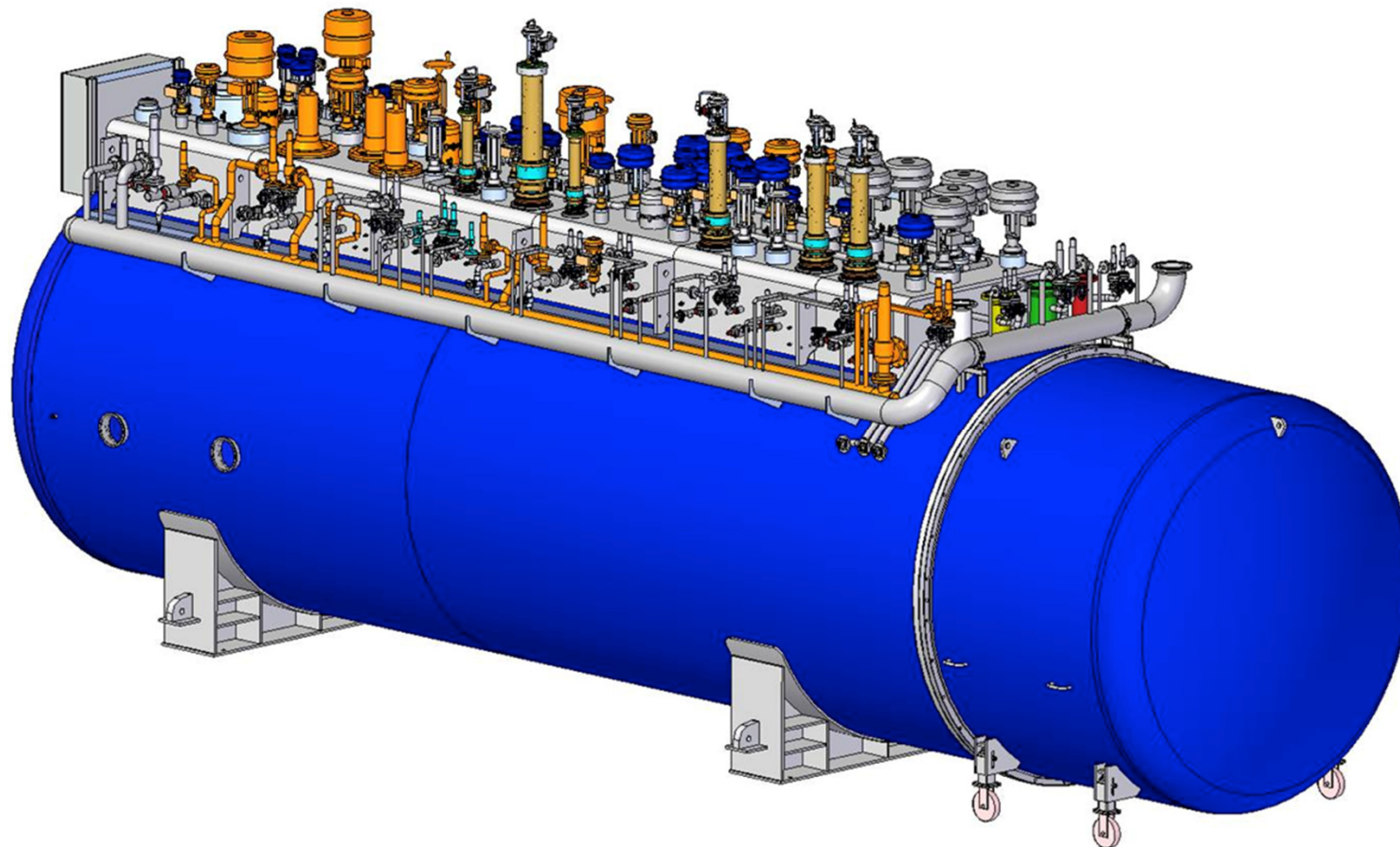

# Construction of Accelerator Cryoplant is well underway

## Cold Box Valve Plate



Successful FAT of all Aerzen screw compressors for the ACCP took place in Germany this July.

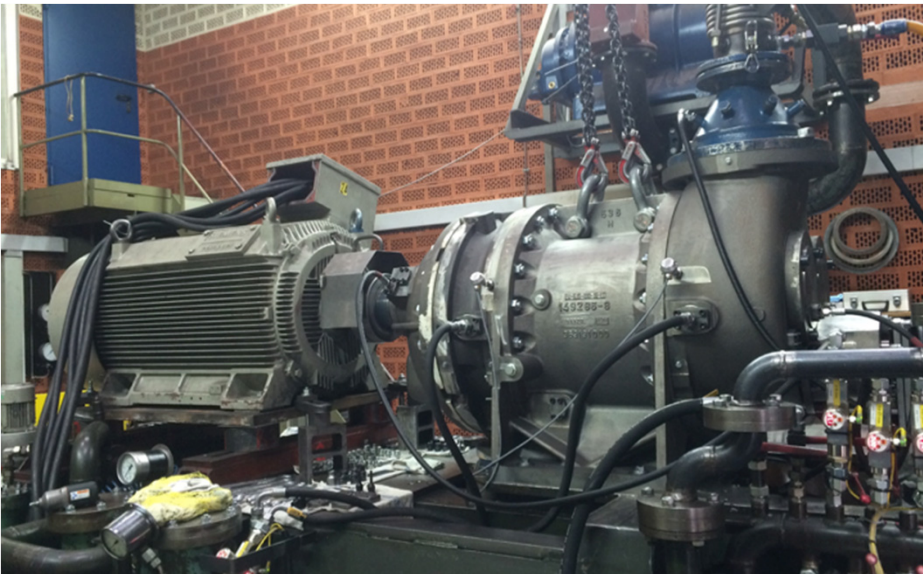

# Cryogenic Distribution System

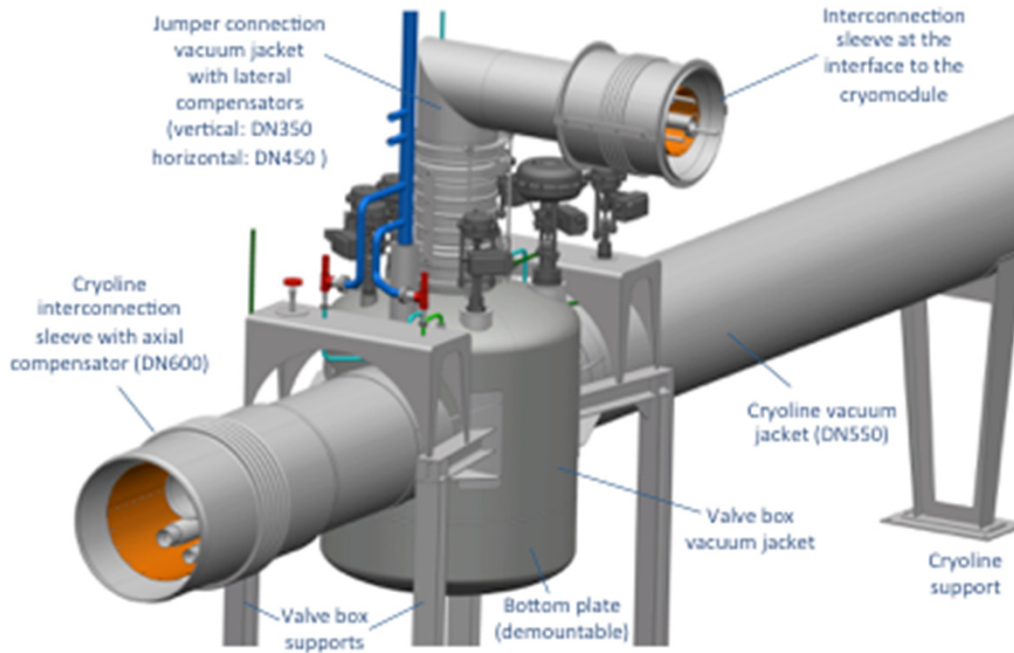

Detailed Design of Elliptical CM Cryogenic Distribution System  
IK contribution by WUST (Poland)  
Currently in procurement and construction



Top Plate of Prototype →  
Valve box for Spoke CM cryodistribution system  
IK contribution by IPN Orsay CDR planned for Q1 2017

# WP 17 - Reduced Scale modulator prototype ( SML topology status on August 2016 )

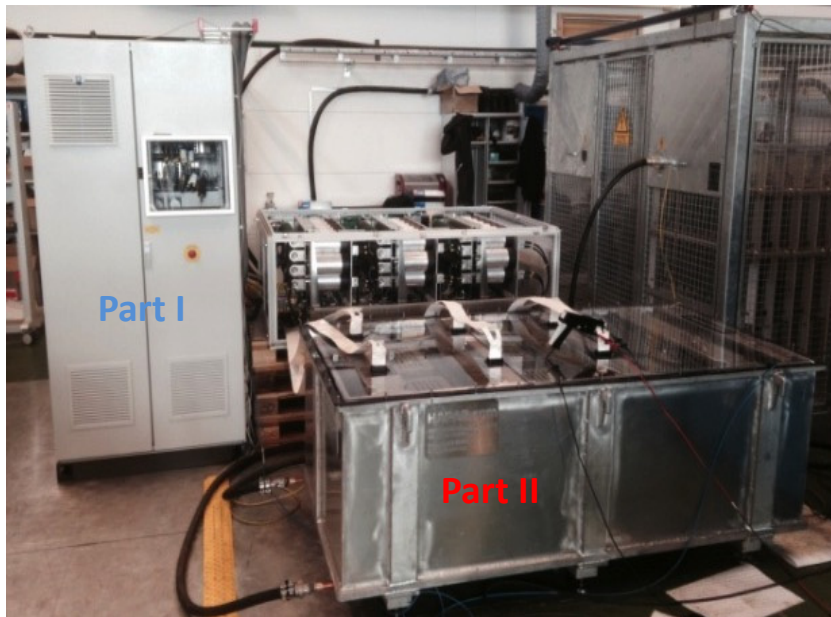

- Integrated test of complete system, Part I + Part II:

**Type of oil was changed from MIDEL 7131 to SHELL DIALA**

→ Heat run test successfully performed at nominal operating point (115kV, 20A, 3.5ms/14Hz) for 12 hours consecutively;

- no voltage breakdowns observed;
- slight increase of the oil temperature up-to 60 ° C (should stay below 50 ° C);
- Cooling was improved by adding an oil pumping system for continuous oil circulation via oil/water heat exchanger

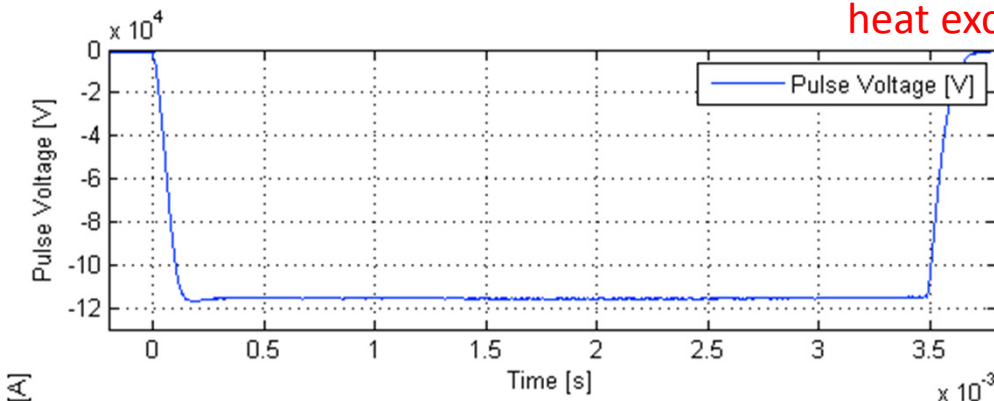

# 660kVA modulator design

( SML topology – Supply of 4 704MHz klystrons in parallel)

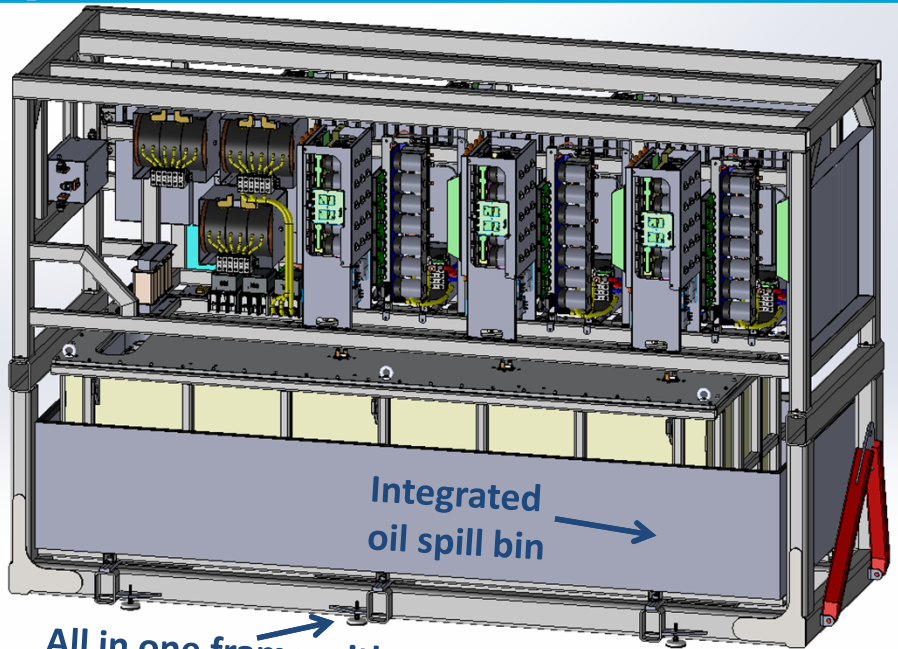

All in one frame with permanently mounted wheels for easy transportation

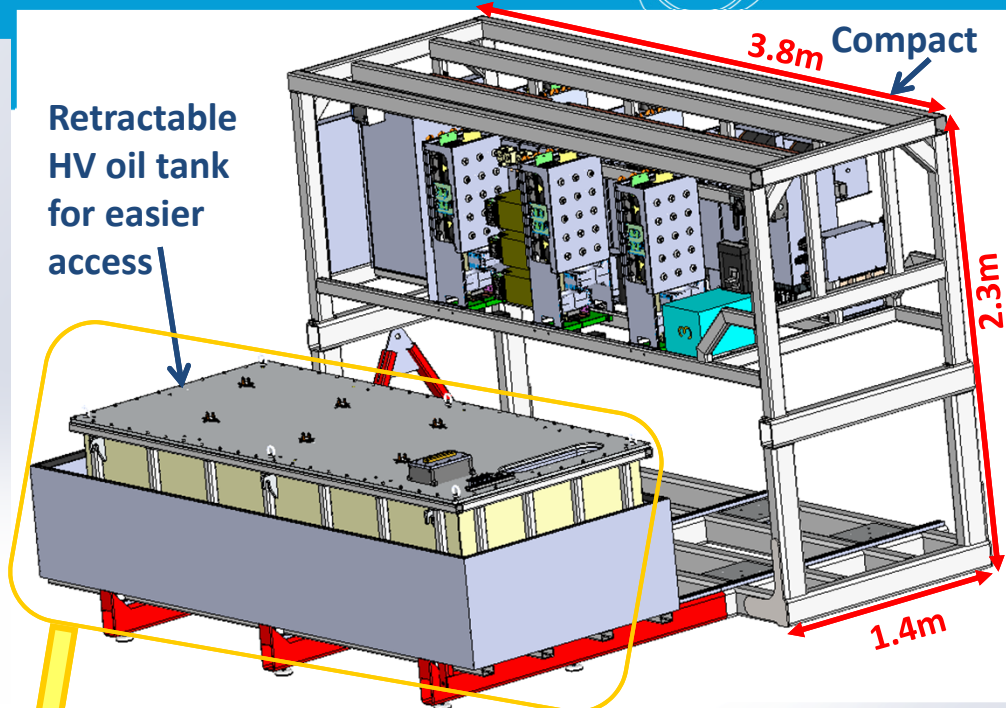

- Total footprint: 3.8m x 1.4m (planned was 5.5m x 1.6m, i.e. 40% less);
- Total weight: < 4 tons (without oil);
- Total volume of oil: ~ 2200 liters;

• Preparation of “Build to Print” documentation for tendering:

**Completed:** → Detailed Electrical Schematic; → 3D CAD drawings; → Bill Of Materials (BOM);

**Ongoing:** → Technical Specification writing; → PDR is foreseen for early October

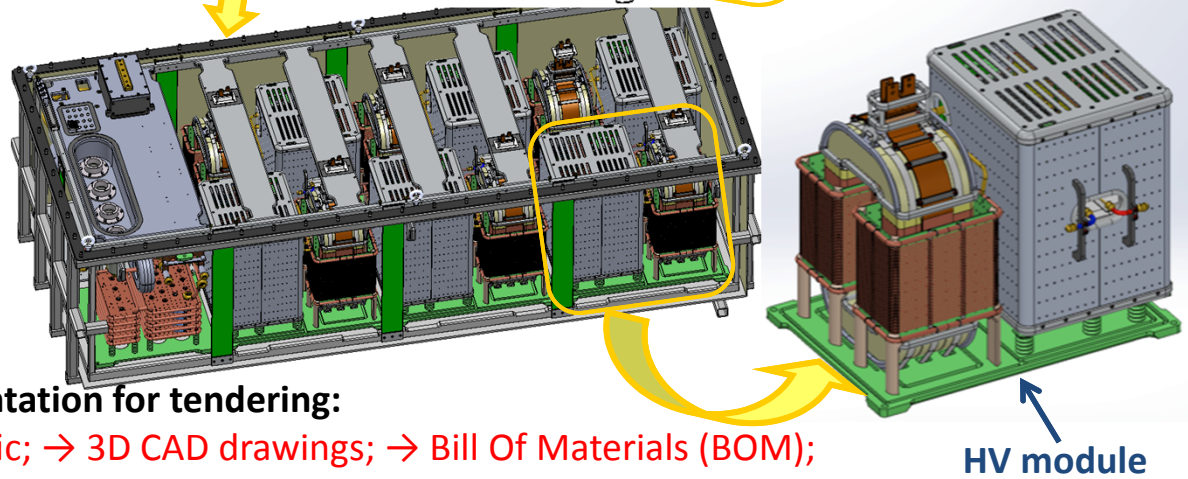

# RF System Summary

Frequency	Component	Solution	In Kind?	Comments
352 MHz	RFQ/DTL	Klystron	Yes (ESS Bilbao)	
352 MHz	MEBT Bunchers	Solid State	Yes (ESS Bilbao)	
352 MHz	Spoke Cavity CM	Tetrodes	Yes (Elettra)	
704 MHz	Medium beta Cavity CM	Klystrons	No	
704 MHz	High beta Cavity CM	Klystrons or IOTs	possible	Technology choice made in Mid 2018

# Significant Progress in Site Construction in Lund

**AUGUST 2016**

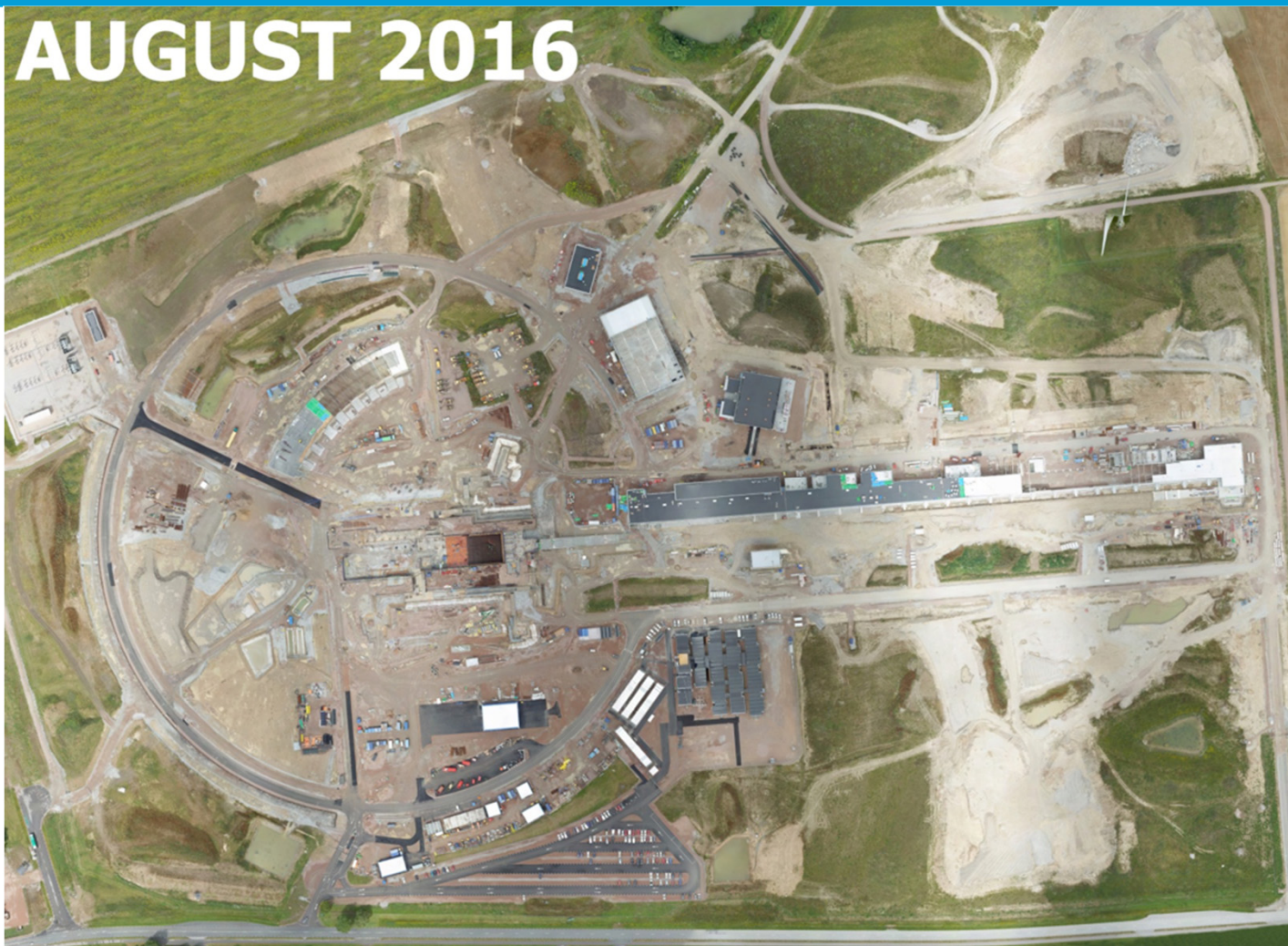



Tunnel

## Klystron Gallery, Stubs and Tunnel Roof



## Cold Box Building



## Klystron Gallery



- The ESS accelerator will be the world's most powerful proton linac
- In Kind Contributors will provide more than 50% of all accelerator systems and almost 100% of beam line components
- The ESS accelerator is well underway with most systems entering series production by the end of 2016. Initial technical installations will start in November of 2016
- The project is on track to having first beam on target in June 2019

# ACKNOWLEDGEMENT



This work describes the efforts of more than 200 people working at ESS, in partner institutions and in industry. It is the talent and hard work of these people that will make the ESS accelerator a success.