

Optics and mechanics of mirror benders

Josep Nicolas
Claude Ruget
Carles Colldelram

SLAC NATIONAL
ACCELERATOR
LABORATORY



MEDSI 2016

MECHANICAL ENGINEERING DESIGN OF SYNCHROTRON
RADIATION EQUIPMENT AND INSTRUMENTATION



- 1. Basics of x-ray mirror optics**
- 2. Characteristics of elliptic mirrors**
- 3. Mirror bender calculations and metrology**
- 4. Mechanical design of mirror benders**



1. Basics of x-ray mirror optics

- *Focusing with reflective optics*
- *Surface error, aberration*

Refractive index of x-rays

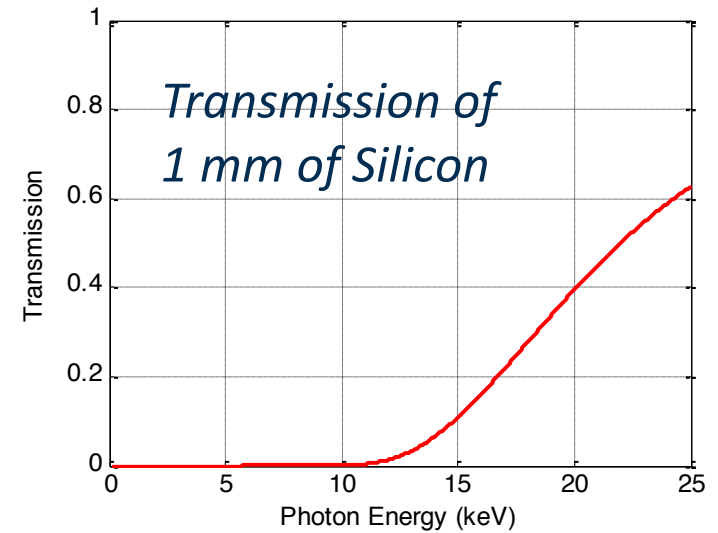
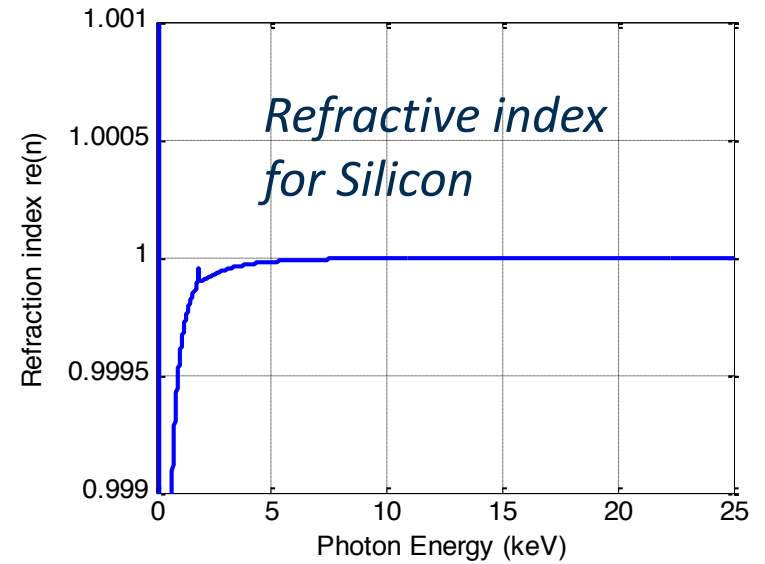
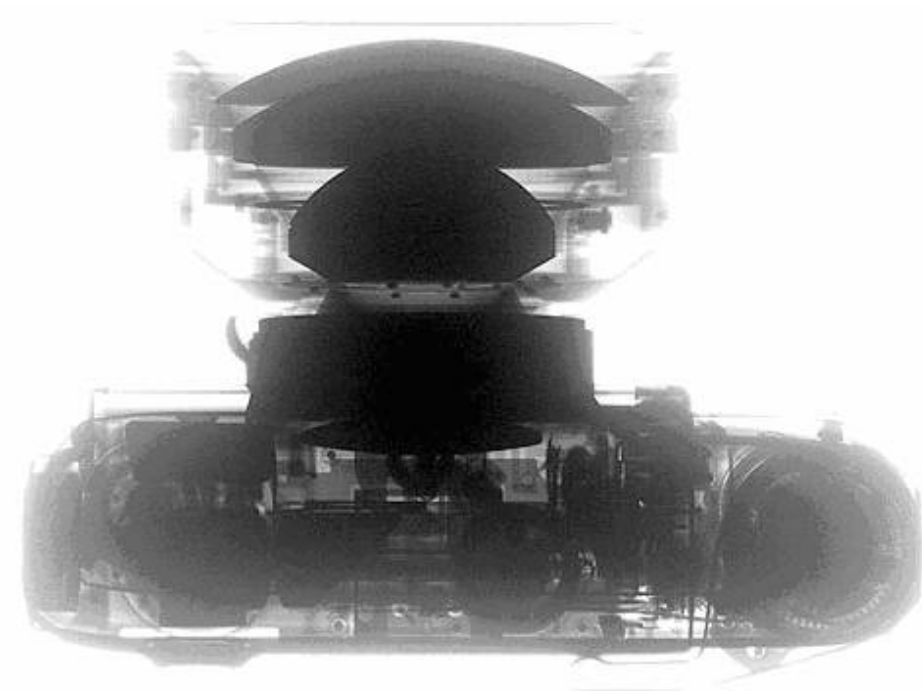

Total reflection

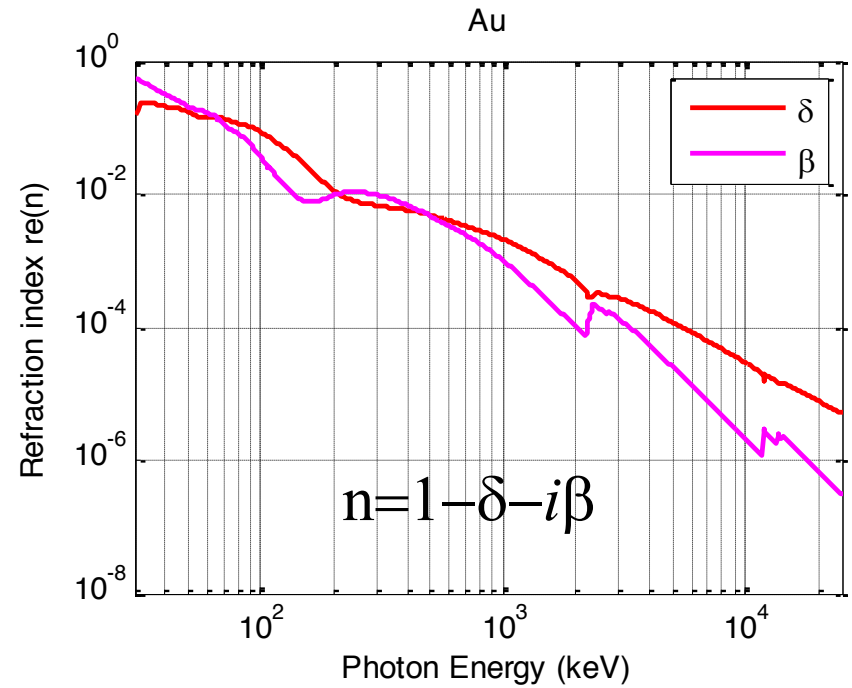
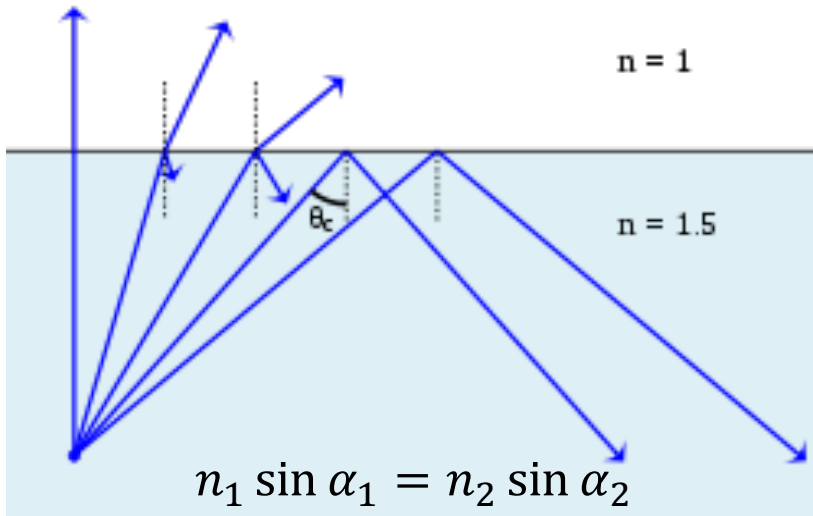

$$\theta_c = \sqrt{2\delta}$$



Mirror 400 mm (toroidal)

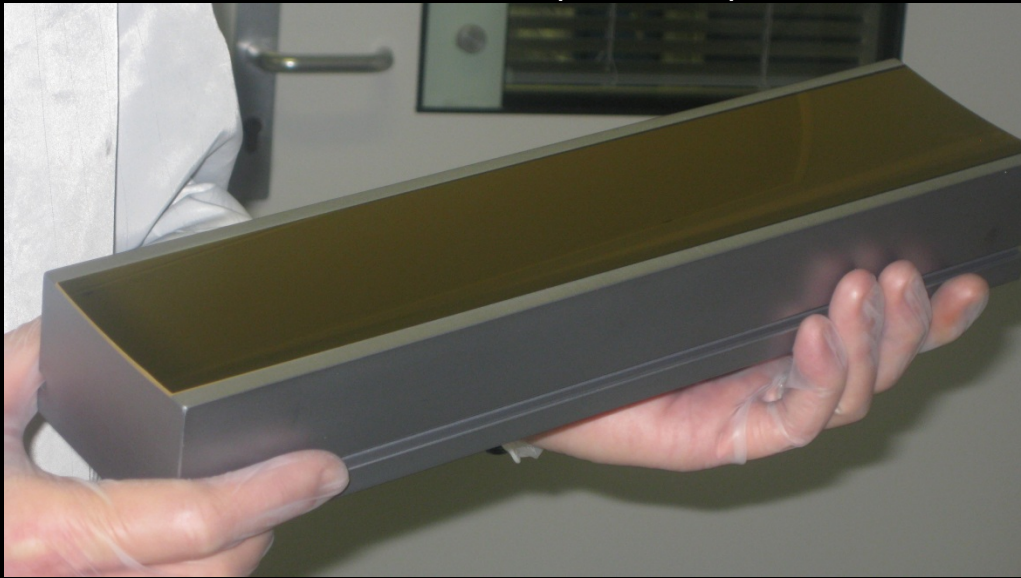

Mirror 1200 mm (plane elliptic)

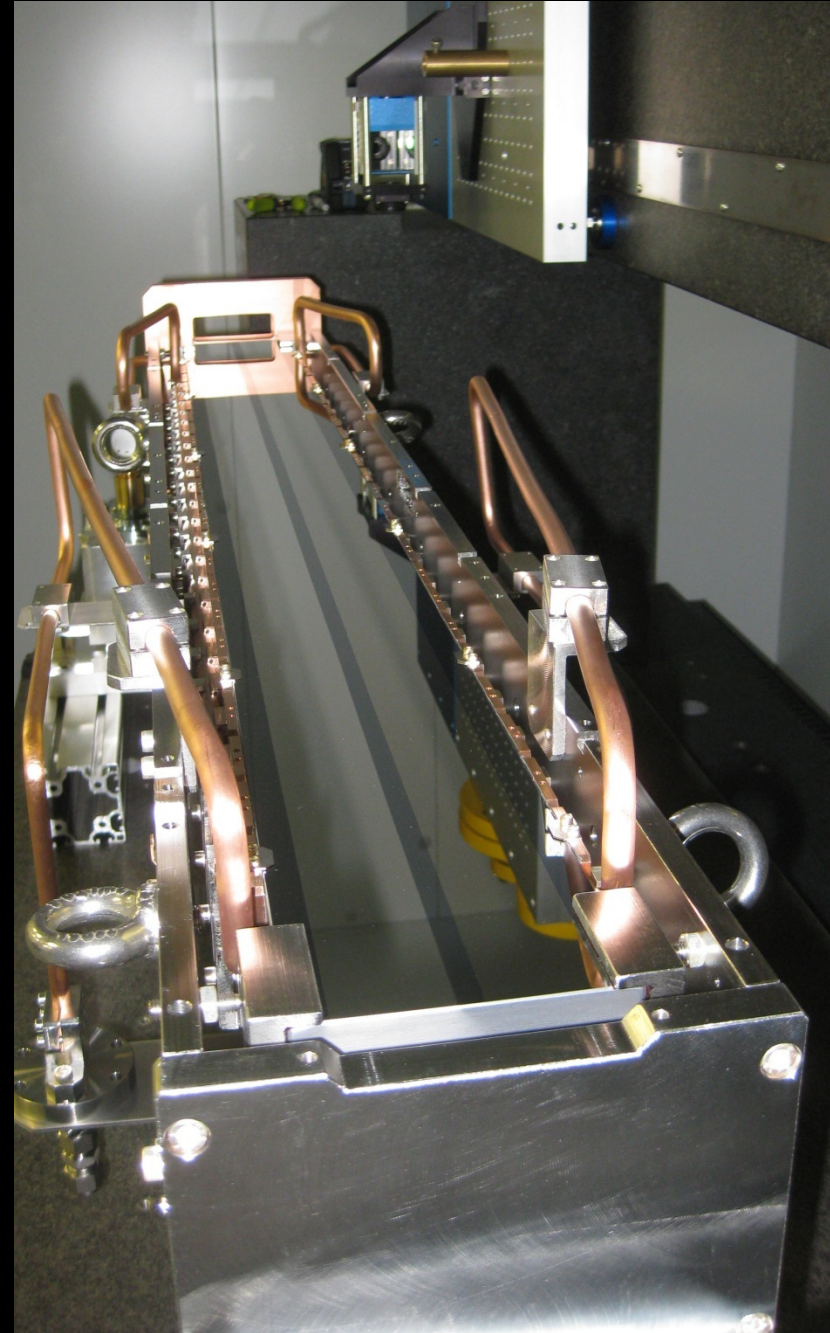

A mirror in its vessel

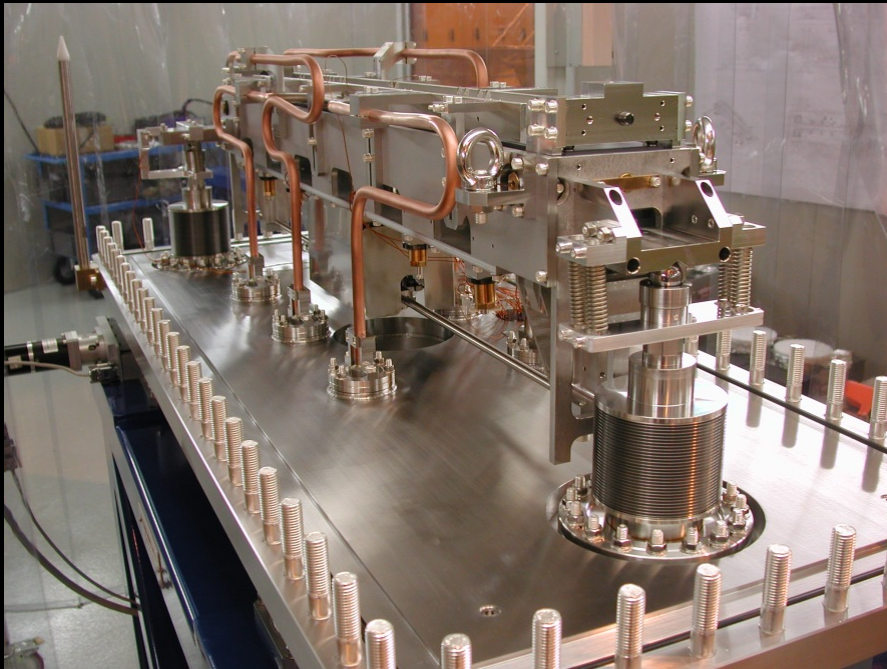

To focus (v.)

An **optical system** images (stigmatically) an **object point A**, onto an **image point A'** if all the rays that depart from A, and reach the optical system, gather at A', independently of their direction.

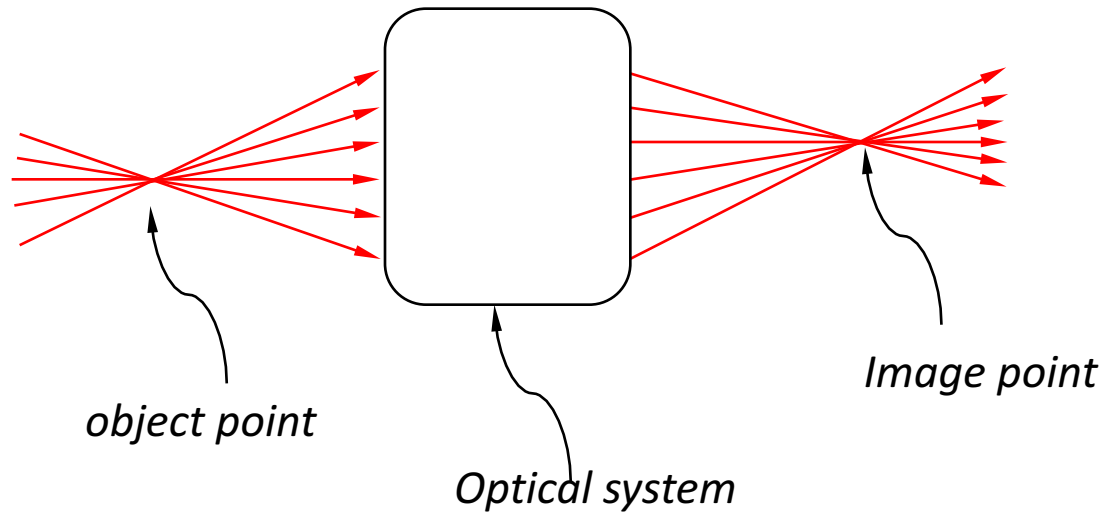

Examples of focusing systems are:

A pinhole, lenses (refraction), mirrors (reflection), Fresnel lenses (diffraction). In (almost) all the cases the focusing element deviates the direction of the incoming rays.



Rays vs Waves

*X-Rays are waves (and photons are their quanta), and to be precise one should do **wavefront** propagation.*

*Geometrical optics, is an approximation, based on propagation of **rays**.*

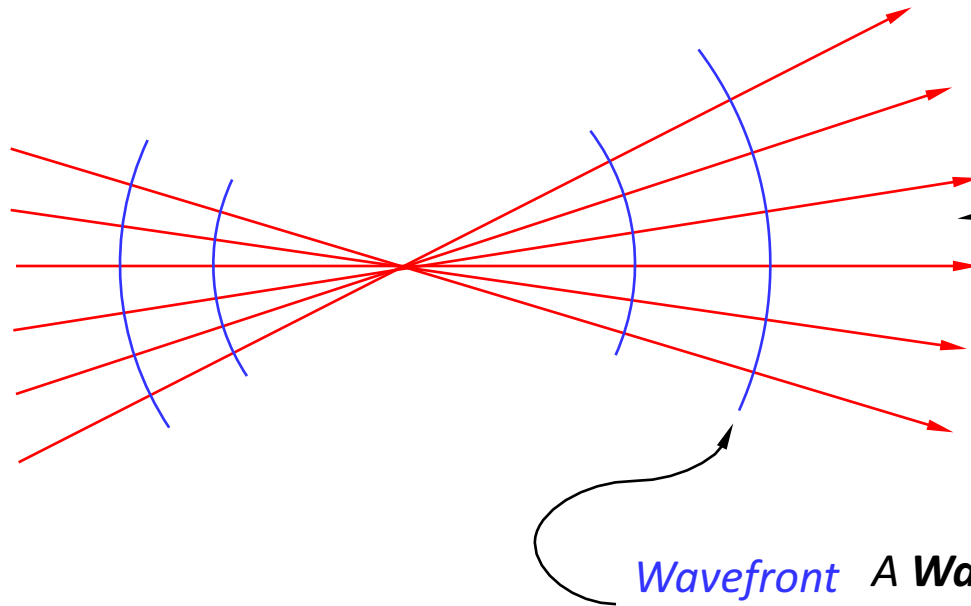

Rays

Rays are the lines that indicate the direction of propagation of energy, direction of variation of phase

Wavefront

A **Wavefront** is the surface of points at the same **optical path distance** from the emission point. (for us, at the same distance), *i.e. phase is constant across a surface*

“Rays are perpendicular to wavefronts”



Ray tracing vs wavefront propagation

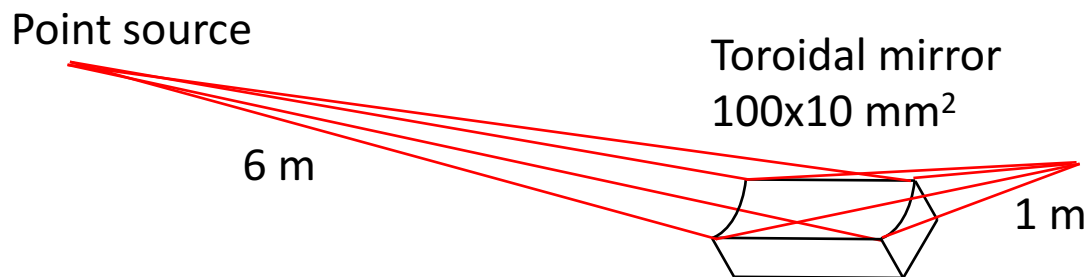

$h\nu=24\text{eV} - \lambda=50\text{ nm}$

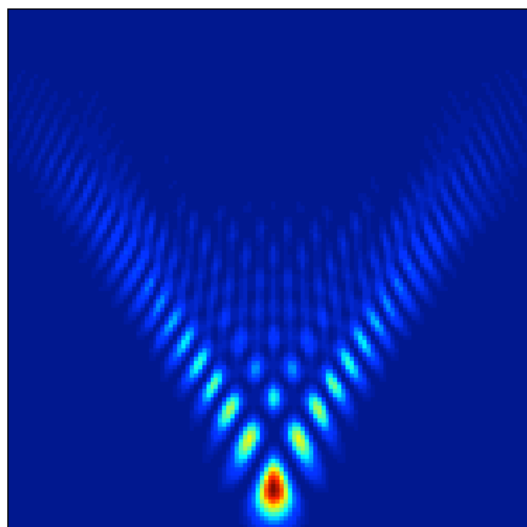

$h\nu=123\text{eV} - \lambda=10\text{ nm}$

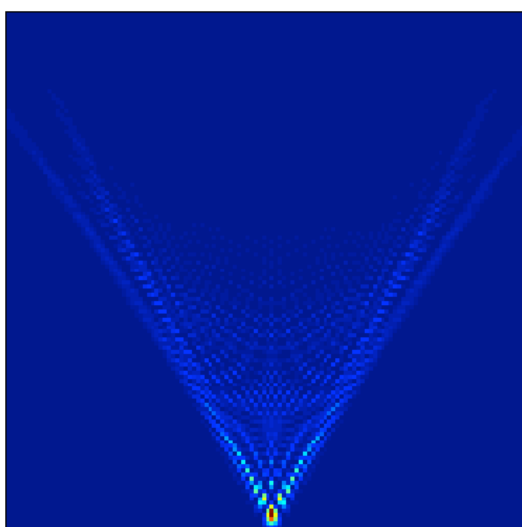

Ray tracing

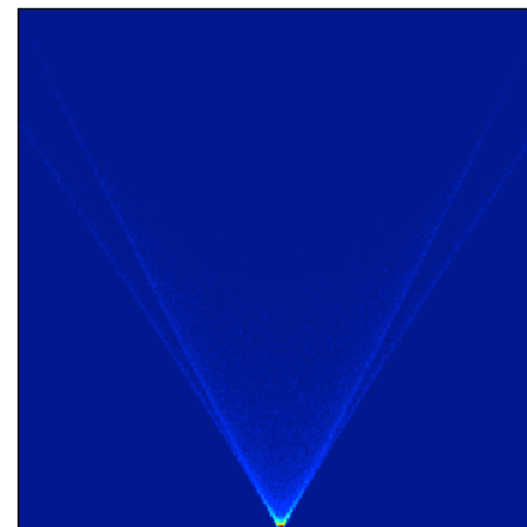

100 μm

Although raytracing cannot account for diffraction or interference effects, it reproduces accurately the images if energy is high enough (short wavelength)

Effect of the source size

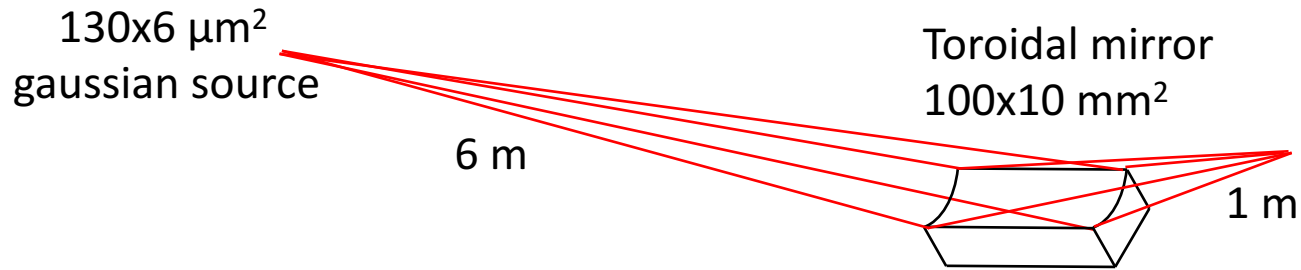

$h\nu=24\text{eV} - \lambda=50\text{ nm}$

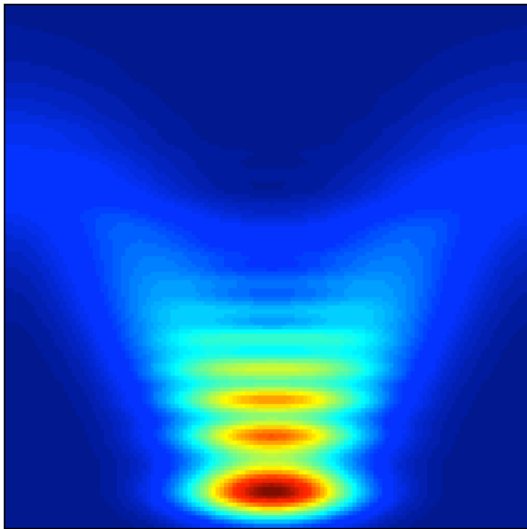

$h\nu=123\text{eV} - \lambda=10\text{ nm}$

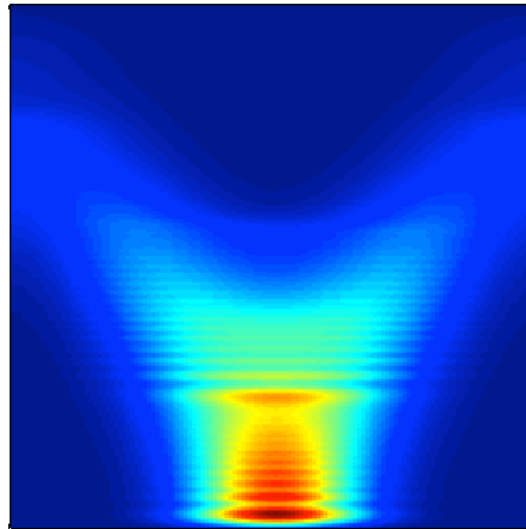

Ray tracing

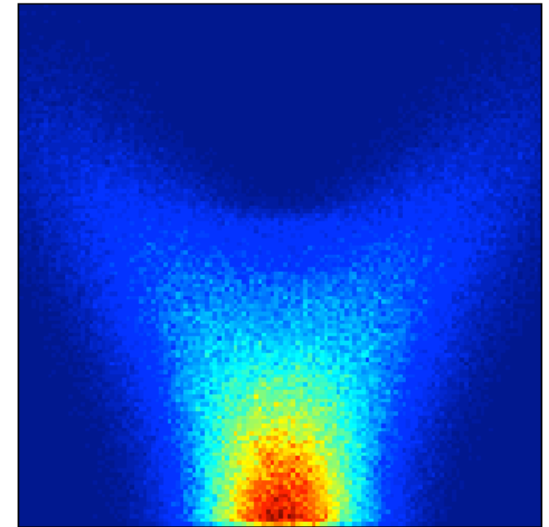

100 μm

The source size of the electron beam reduces the coherence of the beam, and reduces the contrast of wave effects.

Focusing with mirrors

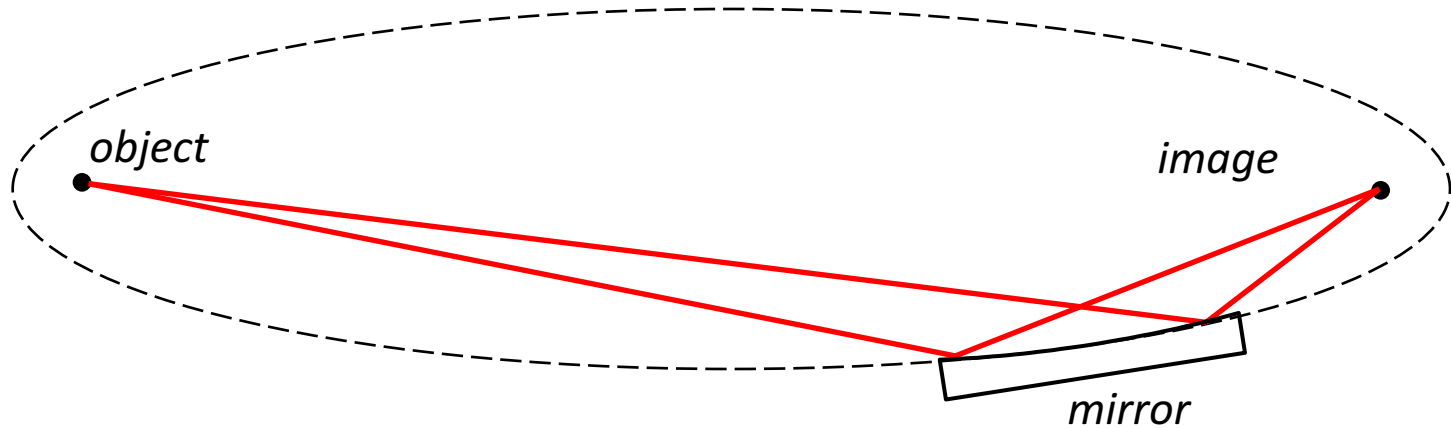

“The sum of the distances to the two foci is constant for all the points of an ellipse”

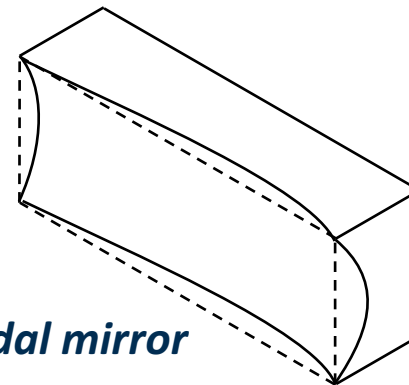

Ellipsoidal mirror



Stigmatic imaging

An ellipsoidal mirror focuses point-to-point *stigmatically*
(or *anastigmatically*)

*Sagittal curvature
varies from upstream
to downstream*

*Local
not c*

Ellipsoidal mirror

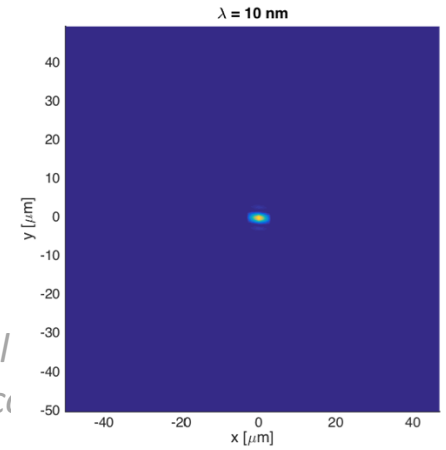

Stigmatic imaging

An ellipsoidal mirror focuses point-to-point **stigmatically**
(or **anastigmatically**)

*Sagittal curvature
varies from upstream
to downstream*

*Local
not c*

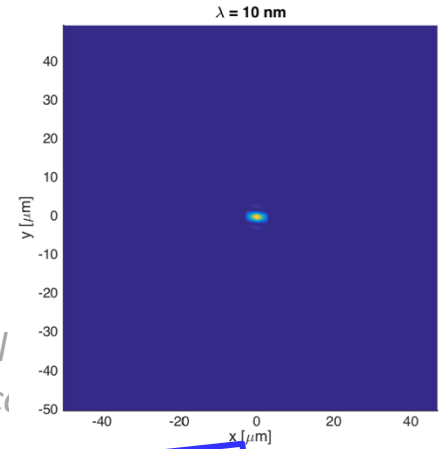

**Ellipsoidal mirror is NOT always the
best option:**

Ellipsoidal mirror
Difficult fabrication → higher figure errors
- Difficult alignment → aberrations



Aberrations

The approximation of the toroidal mirror to the ellipsoid is accurate only in the center of the mirror.

Rays far from it are not properly focused.

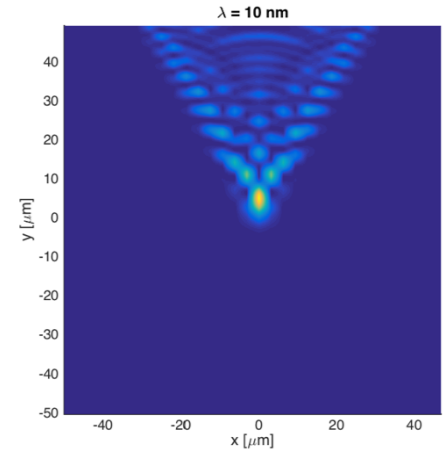

Toroidal aberration

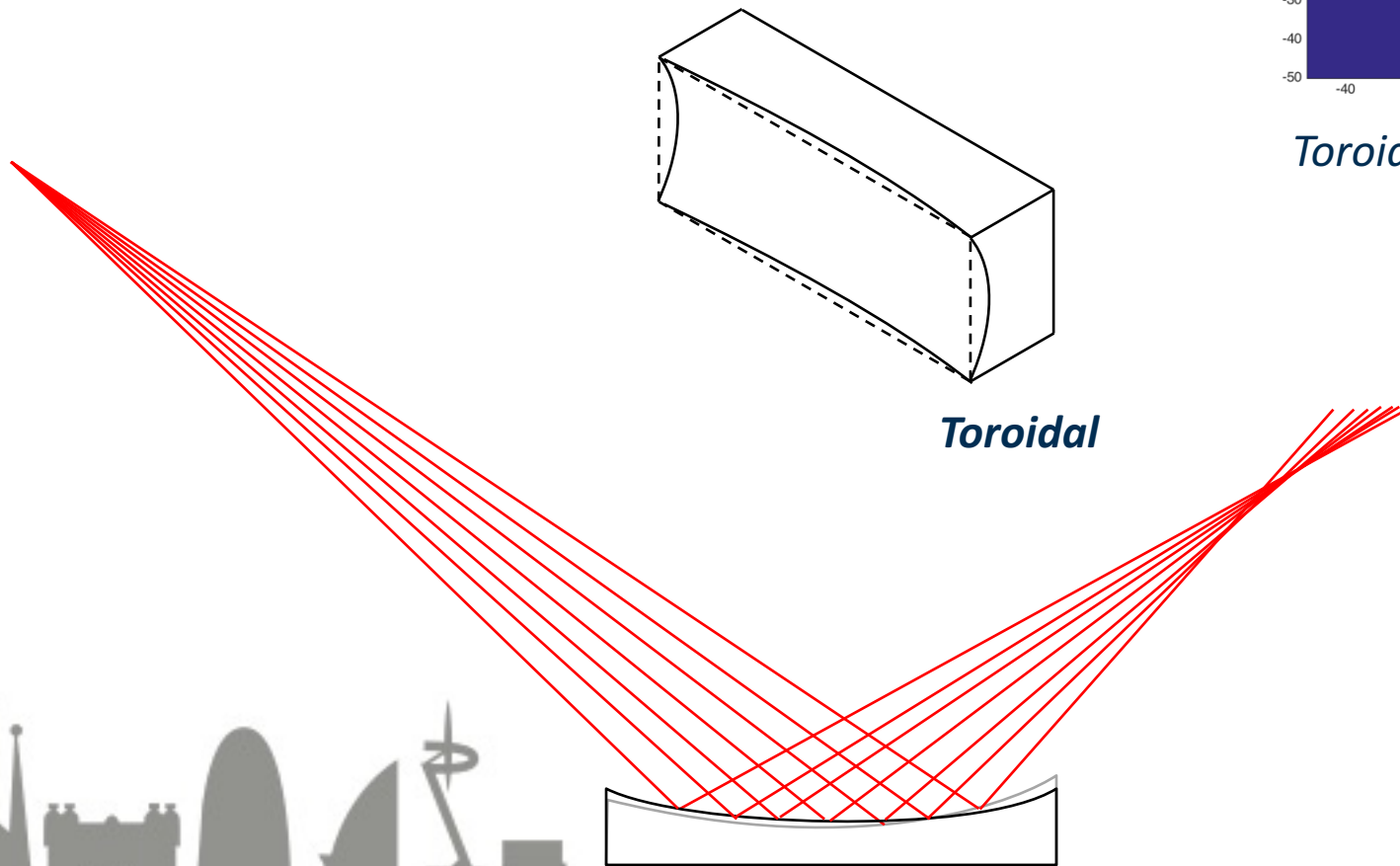

Toroidal



Aberration computing

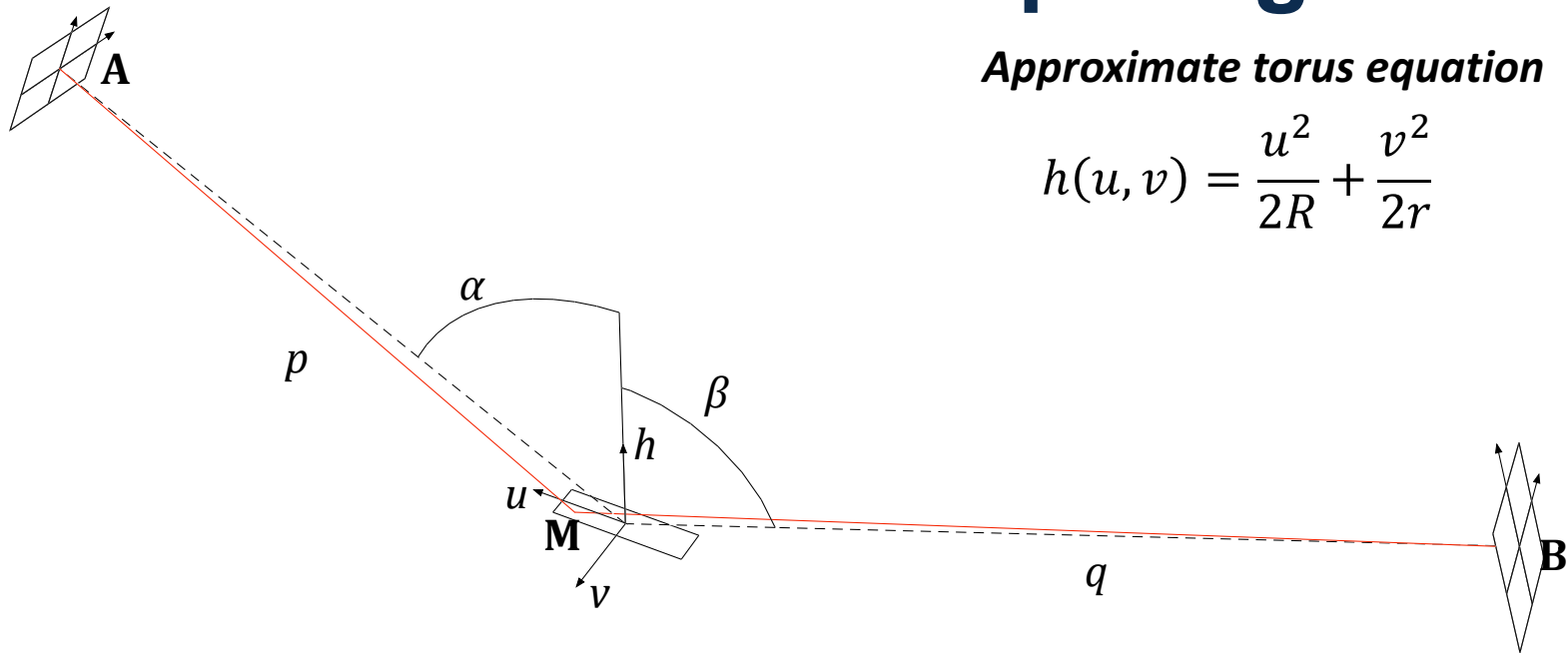

Approximate torus equation

$$h(u, v) = \frac{u^2}{2R} + \frac{v^2}{2r}$$

Optical path difference

$$OPD(u, v) = \| \mathbf{M} - \mathbf{A} \| + \| \mathbf{B} - \mathbf{M} \|$$



Image condition

We need to compute the optical distance between object and mirror, and between mirror and image.

$$\|\mathbf{A} - \mathbf{M}\| = \sqrt{(A_x - M_x)^2 + (A_y - M_y)^2 + (A_z - M_z)^2}$$

It can be expressed as a Taylor series

$$F_{AB}(u, v | p, q, \alpha, \beta, r_i) = \sum_{n=0}^{\infty} \sum_{m=0}^{\infty} F_{nm}(p, q, \alpha, \beta, r_i) u^n v^m$$

$$F_{nm}(p, q, \alpha, \beta, R_i) = \frac{1}{n! m!} \left. \frac{\partial^{n+m} F}{\partial u^n \partial v^m} \right|_{(0,0 | p, q, \alpha, \beta, r_i)}$$



Main aberrations

- F_{20} meridional defocusing*

$$F_{20} = \frac{\cos^2 \alpha}{2} \left(\frac{1}{p} + \frac{1}{q} - \frac{2}{R \cos \alpha} \right)$$

- F_{02} sagittal defocusing

$$F_{02} = \frac{1}{2} \left(\frac{1}{p} + \frac{1}{q} - \frac{2 \cos \alpha}{r} \right)$$

- F_{30} primary coma*

$$F_{30} = \frac{\sin \alpha \cos^2 \alpha}{2} \left(\frac{1}{p} - \frac{1}{q} \right) \left(\frac{1}{p} + \frac{1}{q} - \frac{1}{R \cos \alpha} \right)$$

- F_{12} astigmatic coma

$$F_{12} = \frac{\sin \alpha}{2} \left(\frac{1}{p} - \frac{1}{q} \right) \left(\frac{1}{p} + \frac{1}{q} - \frac{\cos \alpha}{r} \right)$$

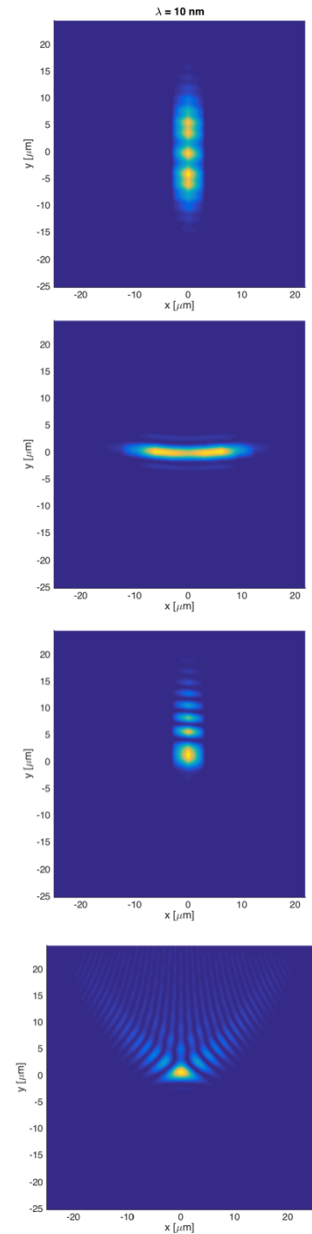

F_{20} F_{30} Will appear again on the tutorial



Varying the incidence angle

The basic equation for paraxial optics is the focus condition

Meridional focusing

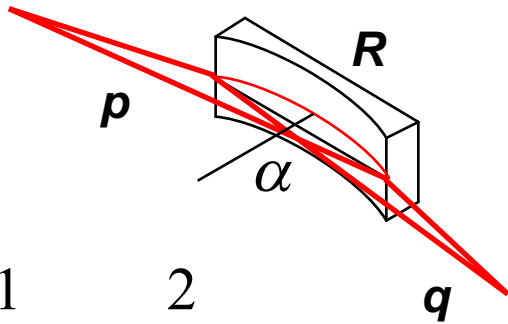

$$\frac{1}{p} + \frac{1}{q} = \frac{2}{R \cos \alpha}$$

Sagittal focusing

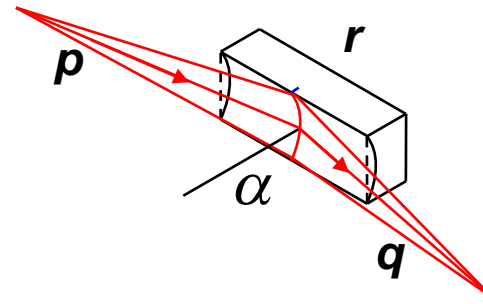

$$\frac{1}{p} + \frac{1}{q} = \frac{2 \cos \alpha}{r}$$

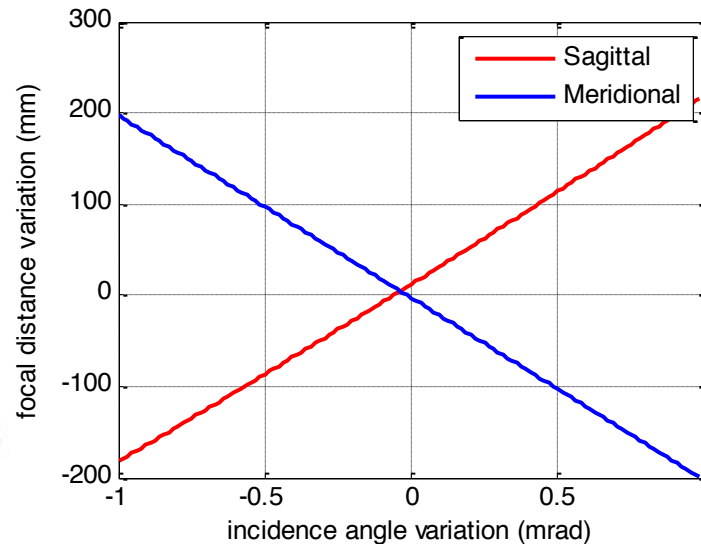

Varying the incidence angle

When one changes the pitch of a focusing mirror, one steers the beam, but also changes the incidence angle (therefore the focusing).

$$dz_I = 2qdP + \left(1 - \frac{q}{p}\right) dZ$$

$$d\theta = +dP - \frac{dZ}{p}$$

$$dP = \frac{1}{p+q} dz_I + \frac{p-q}{p+q} d\theta$$

$$dZ = \frac{p}{p+q} dz_I - \frac{2pq}{p+q} d\theta$$

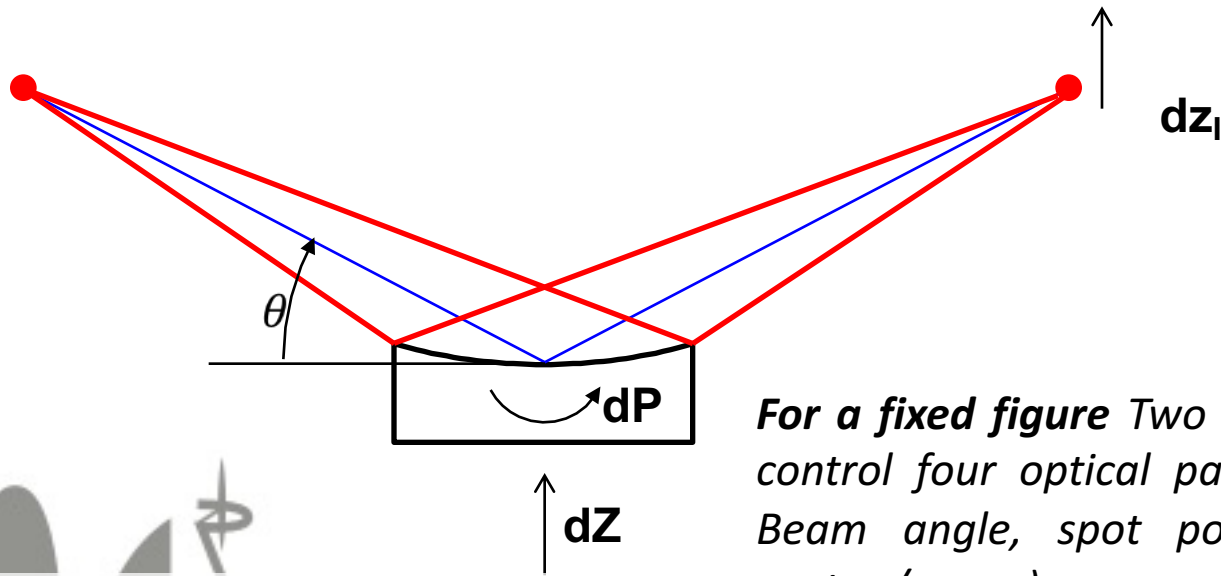

For a fixed figure Two motors (pitch, z) control four optical parameters (focus, Beam angle, spot position, footprint center / coma)

Special cases. 1:1 magnification. Flat mirrors

Figure error: slope

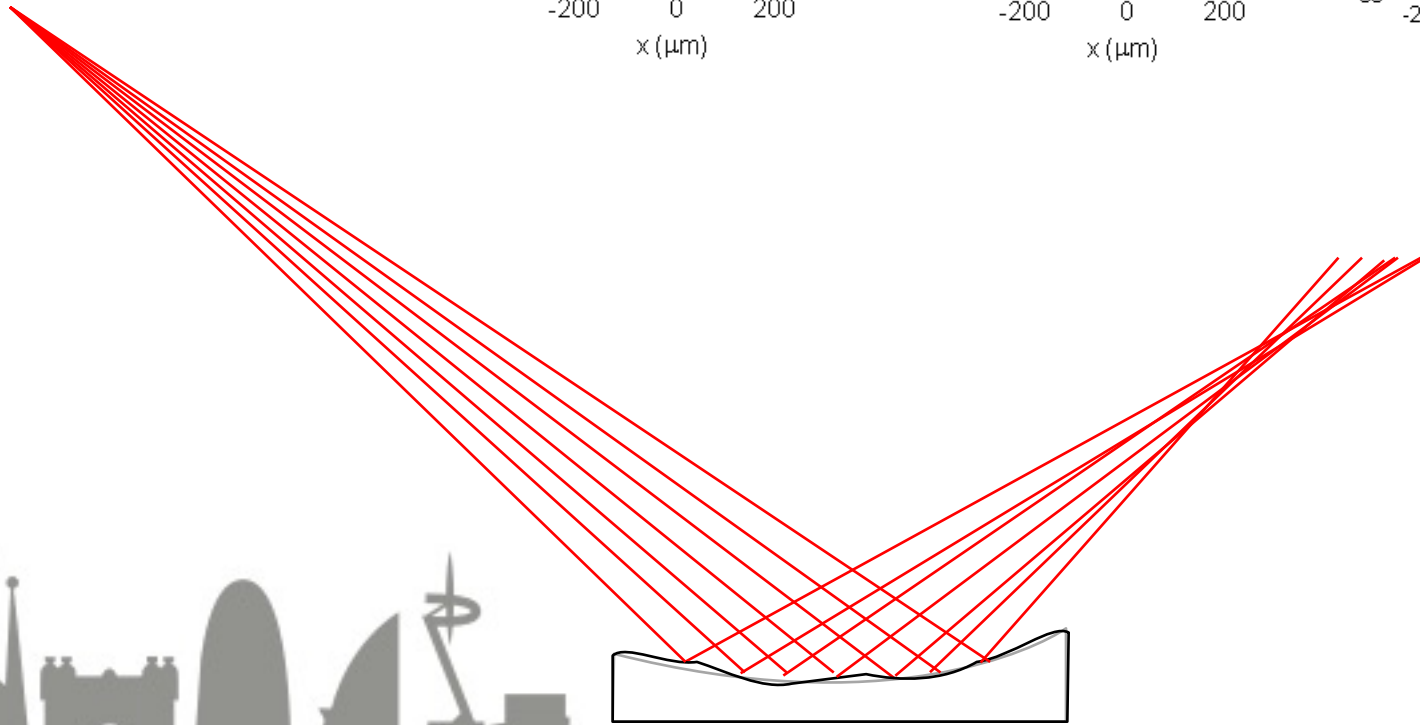
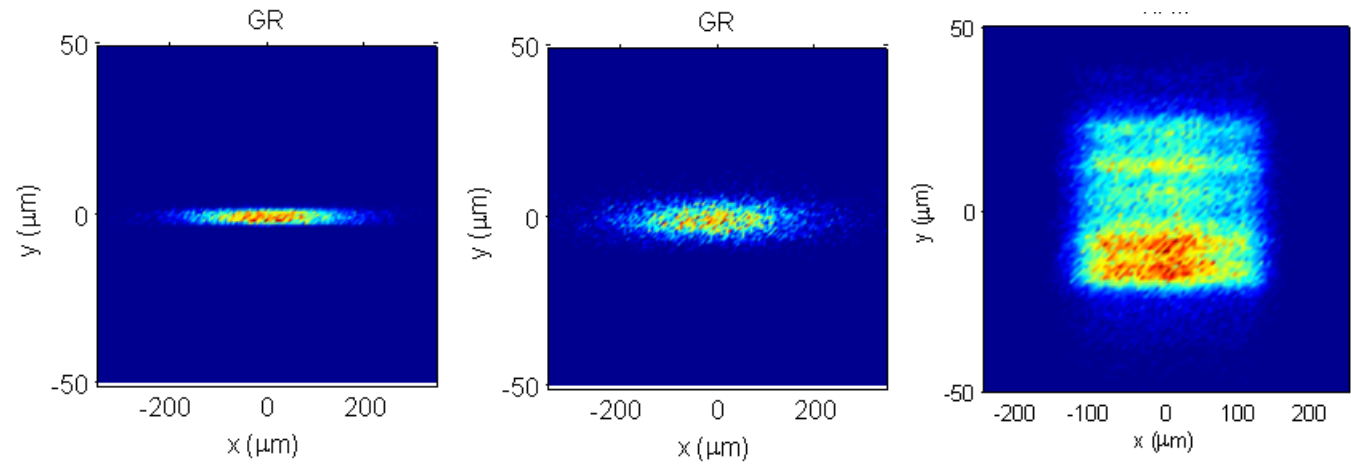

Figure error for coherent sources (a case)

For diffraction limited imaging (FELs), one needs to control the **wavefront distortion**, which is given by the residual **height error**.

Just consider the case in which the mirror is perfect almost everywhere except for a step in the center.

-slope error is very small,

- There is **no light on axis** due to destructive interference between the two sides of the wavefront

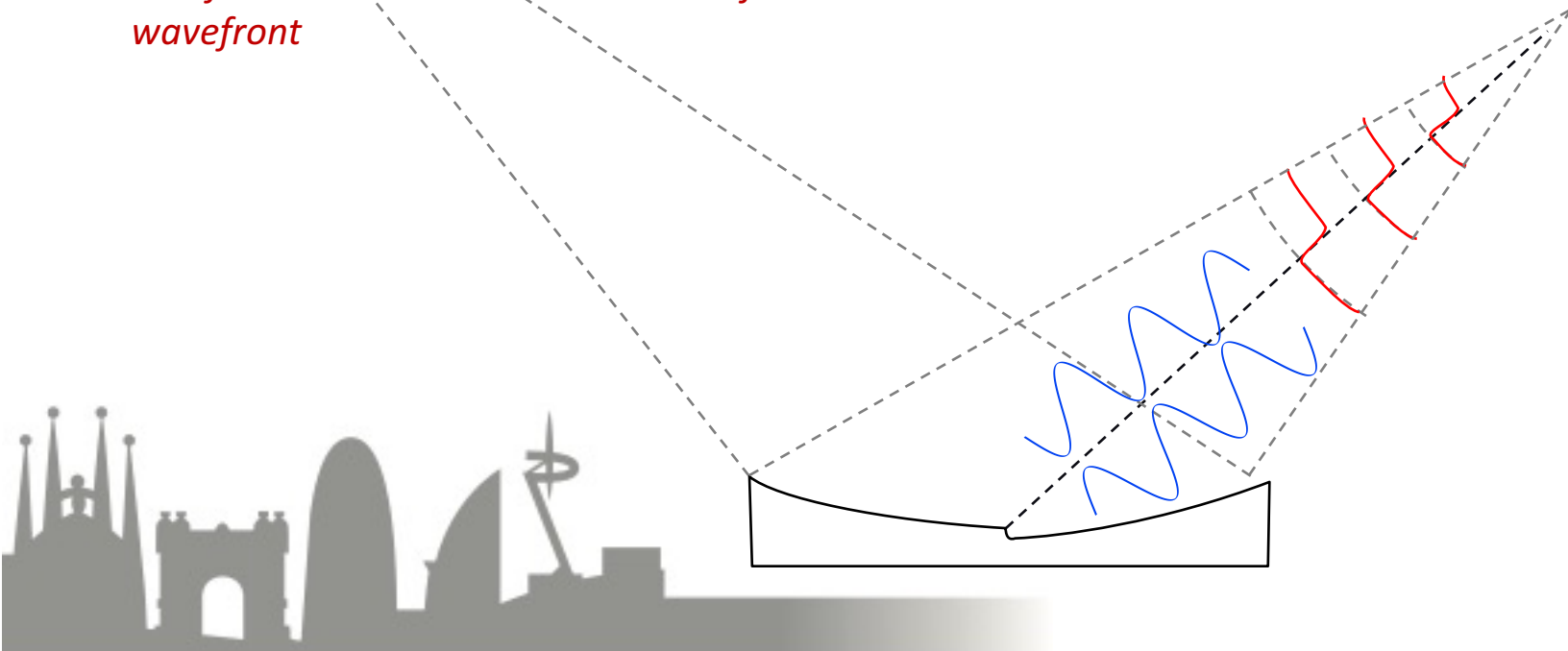
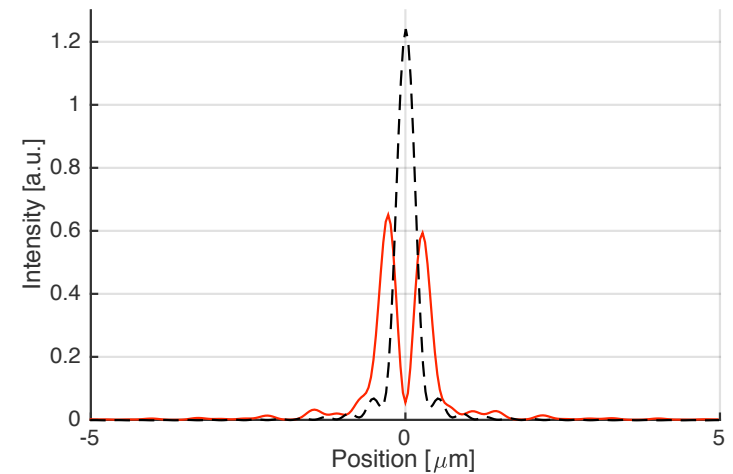
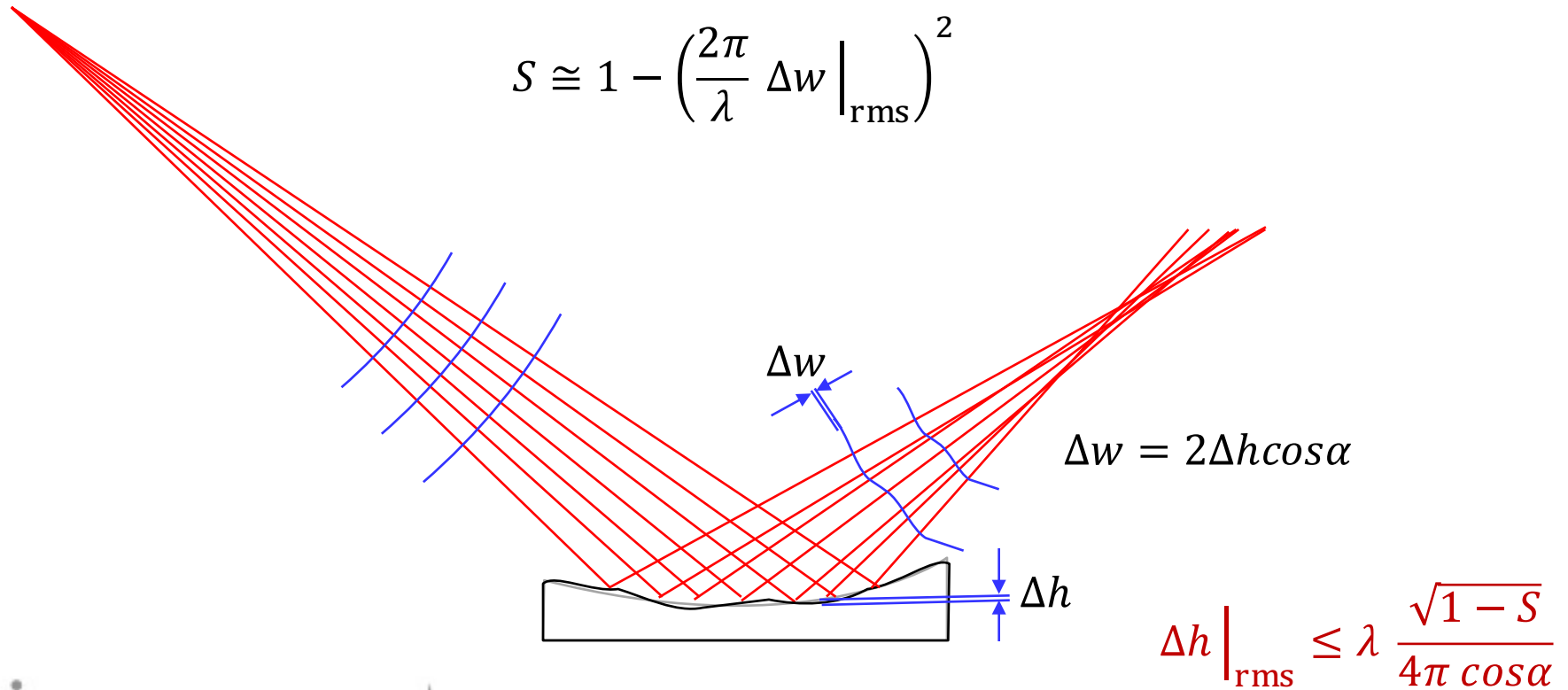

Figure error: height error

Interference effects in image formation are given by the Strehl ratio (actual peak intensity to the error free peak intensity)

$$S \cong 1 - \left(\frac{2\pi}{\lambda} \Delta w \Big|_{\text{rms}} \right)^2$$



Example

LCLS II – $S = 0.97$ - 2.1 mrad -13 keV → 0.4 nm rms



Some reference values of figure error

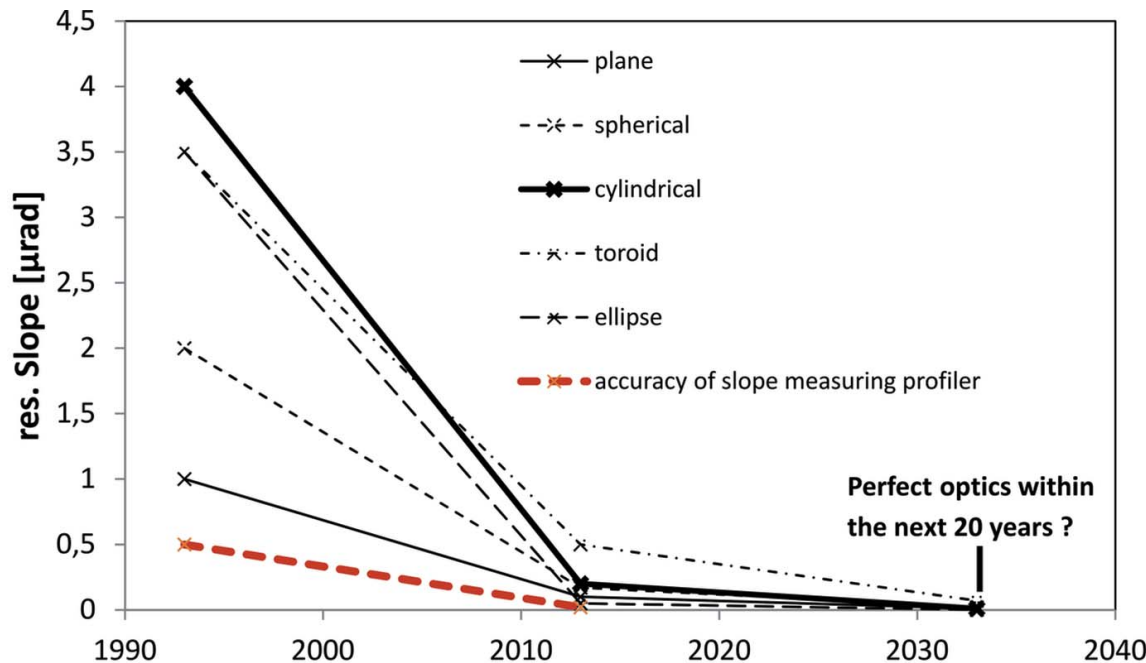

Siewert et al. JSR 21,968-975 (2014)

Quickly evolved in the recent past:

- *Development of mirror metrology*
- *Deterministic polishing techniques:*

Most (usual) companies can deliver mirrors better than $0.5 \mu\text{rad rms}$, on whatever figure and length.

For flats error is sub-nanometer, and slope error below 100 nrad , cost and delivery time.

Sagittal curvature always difficult



Causes of figure error

- *Fabrication error (figuring, polishing metrology) : well below $0.5 \mu\text{rad rms}$*
- *Gravity sag.*
- *Clamping mechanics.*
- *Stress induced by cooling scheme.*
- *Thermal deformations.*
- *Bender errors, ellipse approximatino errors*
- *Coating stress! Bakeout developed stresses (?)*

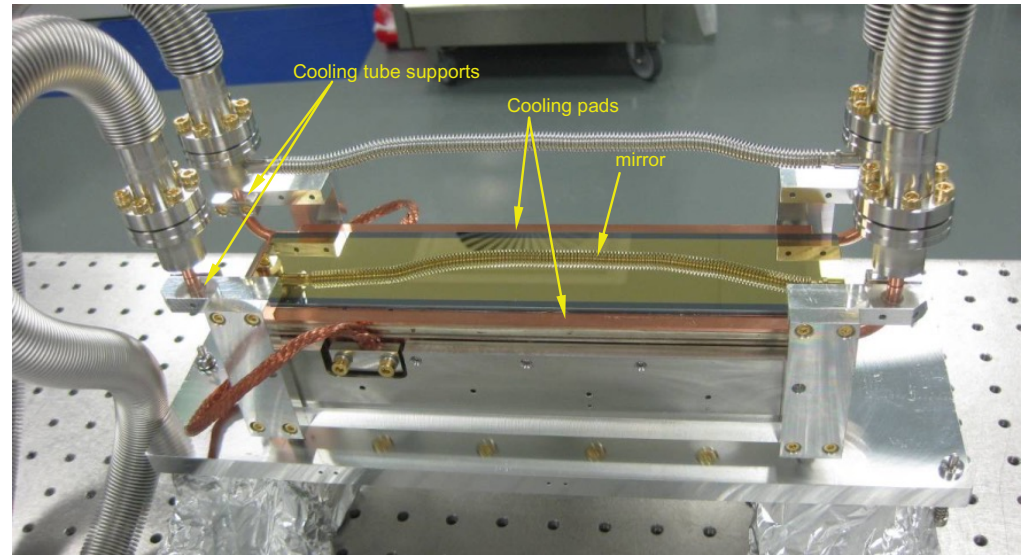

Mirror alone: $R = 331.039 \text{ m} / 0.163 \mu\text{rad RMS}$
In holder: $R = 338.303 \text{ m} / 0.533 \mu\text{rad RMS}$
(First iteration)



Misalignments

Point source

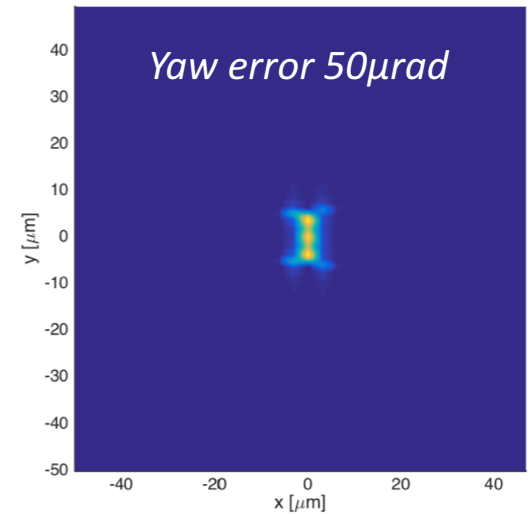
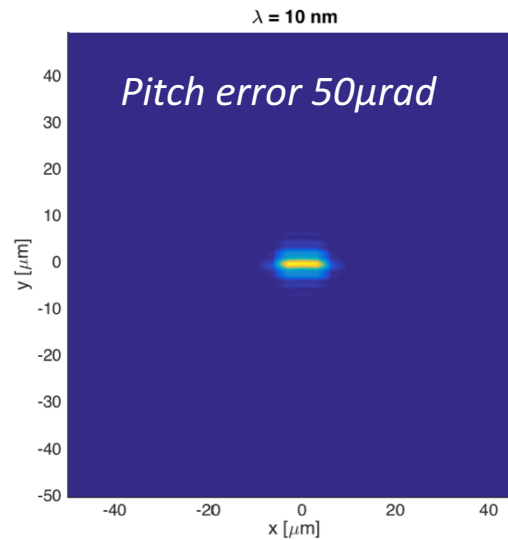
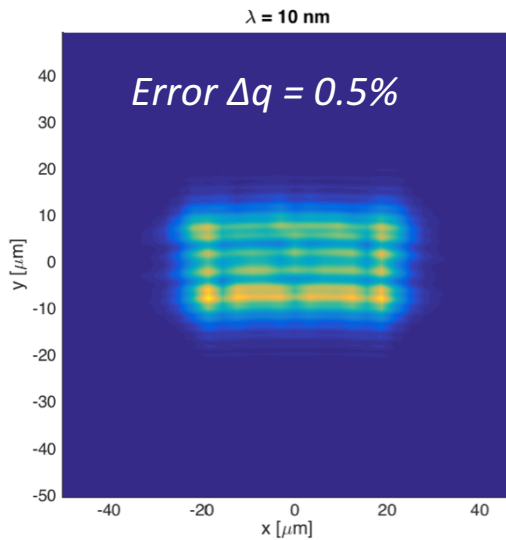
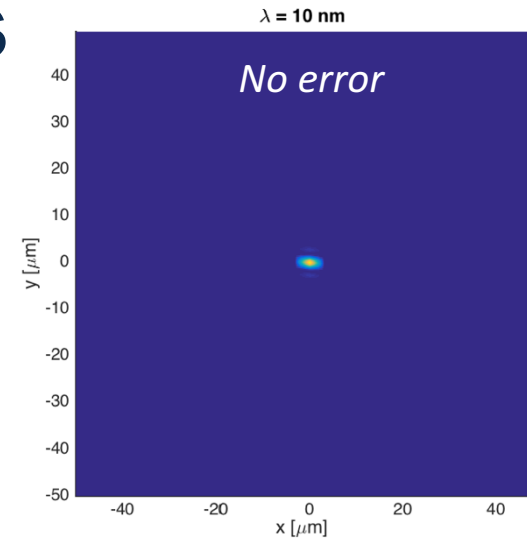
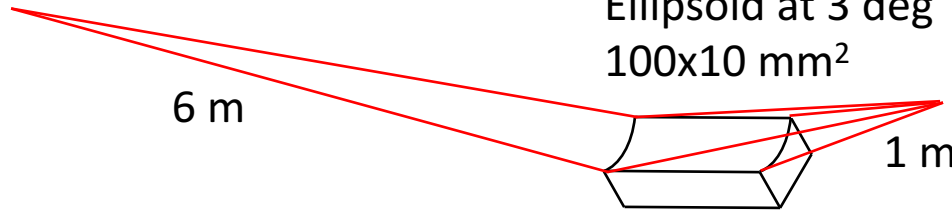

FOV is 100 μm

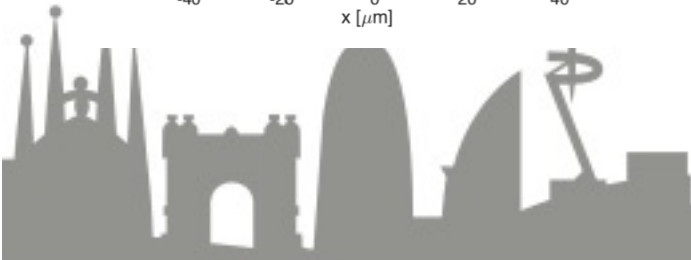

Kirkpatrick-Baez configuration

By decoupling vertical and horizontal focusing, one can obtain aberration free focusing by using high quality mirrors **polished flat**, with low slope error, and **mechanically bent** onto plano-elliptic figure.

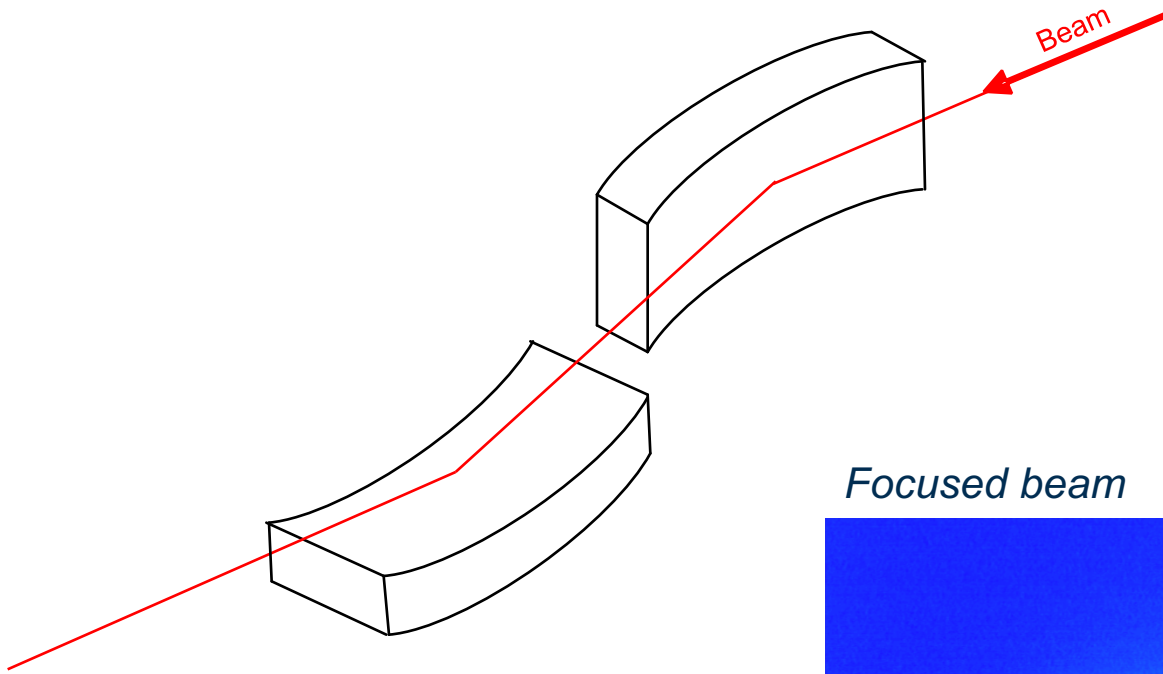

Focused beam

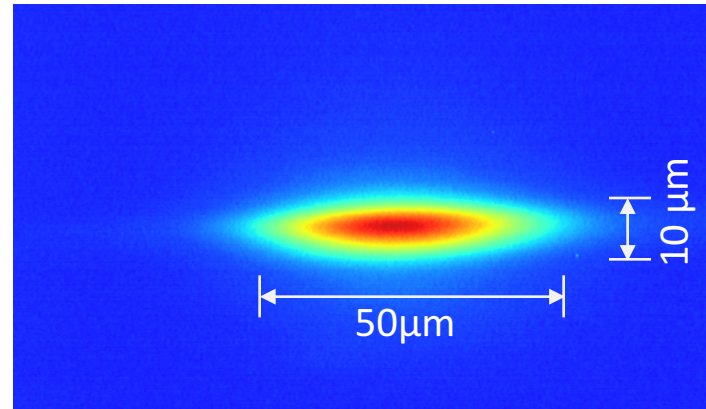

Some KB advantages

- *Decouple horizontal and vertical planes*
 - *Astigmatic sources or images*
- *No sagittal curvature*
 - *Allow different stripes*
 - *More accurate metrology*
 - *Relaxes alignment requirements (no sagittal curv.)*
- **If bender**
 - *Start from flat or spherical mirrors*
 - *Adaptive focus and primary comma*
 - *Several foci*
 - *Focus independent of alignment*

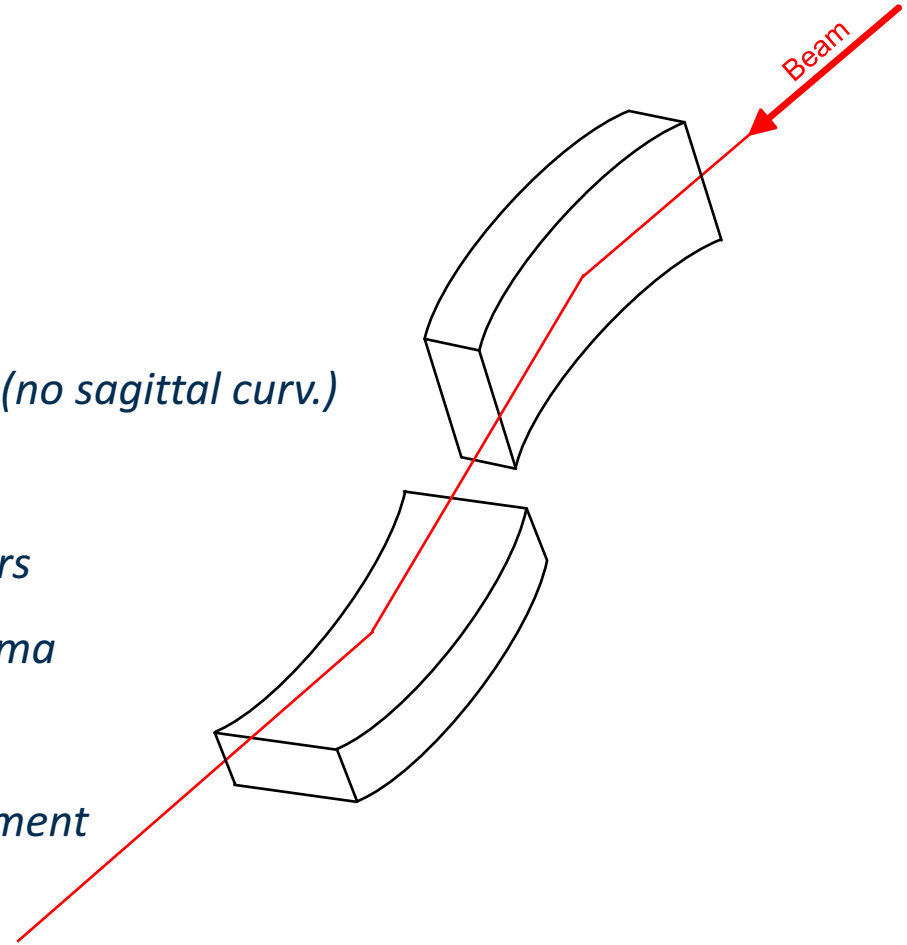





2. Characteristics of elliptic mirrors

- *Geometry of the ellipse.*
- *Height, slope, curvature.*
- *Polynomial approximation.*

Description of an elliptic mirror

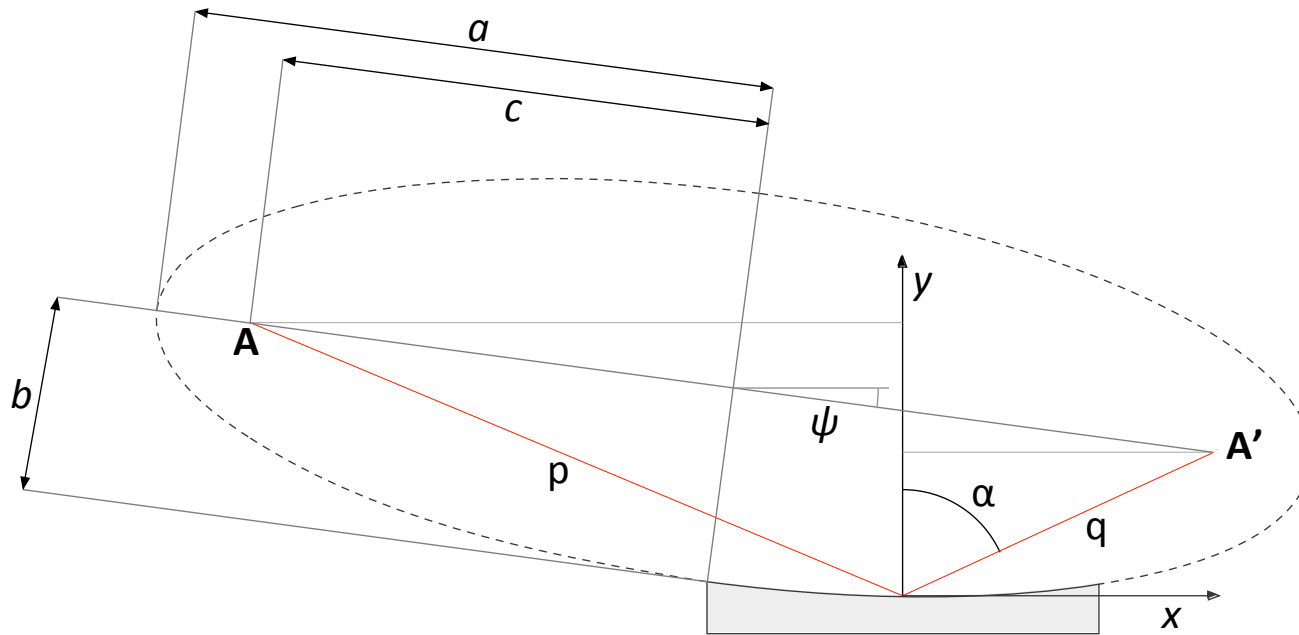

Major semi-axis

$$a = \frac{p + q}{2}$$

Half distance between foci
(linear eccentricity)

$$c = \frac{1}{2} \sqrt{p^2 + q^2 - 2pq \cos 2\alpha}$$

Minor semi-axis

$$b = \sqrt{pq} \cos \alpha$$

eccentricity

$$e = \sqrt{1 - \left(\frac{2}{p + q}\right) pq \cos^2 \alpha}$$

Orientation

$$\tan \psi = \frac{q - p}{q + p} \cot \alpha$$

Equations of the ellipse

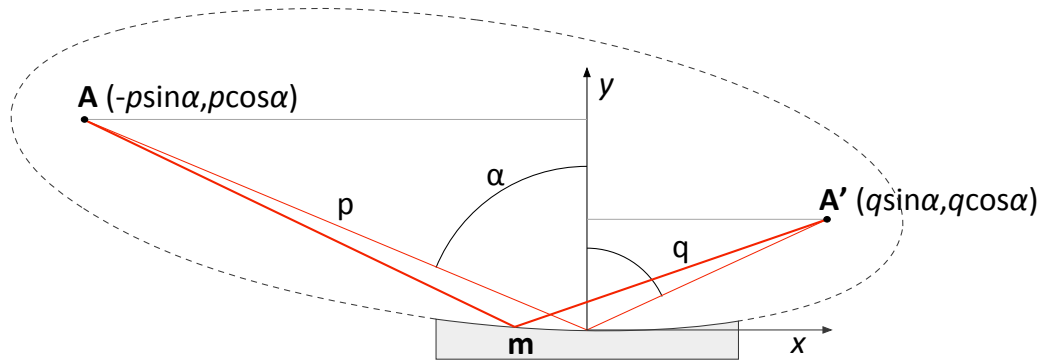

Vector equation of the ellipse

$$\|\mathbf{r}_A - \mathbf{r}_m\| + \|\mathbf{r}_{A'} - \mathbf{r}_m\| = p + q$$

Implicit equation of the ellipse (as a function of coordinates)

$$\sqrt{(x + p \sin \alpha)^2 + (y - p \cos \alpha)^2} + \sqrt{(x - q \sin \alpha)^2 + (y - q \cos \alpha)^2} = p + q$$



Explicit equations of the ellipse

Concave branch of the explicit solution of the ellipse

$$y(x) = -\frac{x(p^2 - q^2) \sin 2\alpha - 4(p + q) \cos \alpha \left(pq - \sqrt{pq} \sqrt{pq - x(p - q) \sin \alpha - x^2} \right)}{p^2 + 6pq + q^2 - (p - q)^2 \cos 2\alpha}$$

- Note that $y(0)=0$
- This is an **exact** solution!

Slope function of the ellipse

$$\frac{dy}{dx}(x) = -\frac{2(p + q) \cos \alpha \left((p - q) \sin \alpha - \frac{\sqrt{pq}((p - q) \sin \alpha + 2x)}{\sqrt{pq - x(p - q) \sin \alpha - x^2}} \right)}{p^2 + 6pq + q^2 - (p - q)^2 \cos 2\alpha}$$

- Note that $y'(0)=0$
- This is an **exact** solution!



Curvature and imaging condition

Curvature of the ellipse

$$\frac{1}{R(x)} = \frac{d^2y}{dx^2}(x) = \frac{\sqrt{pq}(p+q)\cos\alpha}{2[pq - x(p-q)\sin\alpha - x^2]^{3/2}}$$

- *Note that it is not constant*

Curvature at the center of the ellipse

$$\frac{1}{R_0} = \frac{(p+q)\cos\alpha}{2pq}$$

$$\frac{2}{R_0 \cos\alpha} = \frac{1}{p} + \frac{1}{q}$$

- *It is the focusing condition (mer)*



Taylor expansion of the ellipse

Definition

$$y(x) = \sum_{n=0}^{\infty} E_n x^n \quad \text{with} \quad E_n = \left. \frac{1}{n!} \frac{d^n y}{dx^n} \right|_{x=0}$$

In the case of an ellipse, the coefficients are functions of p, q and α

$$E_2 = \frac{\cos \alpha}{4} \left(\frac{1}{p} + \frac{1}{q} \right) = \frac{1}{2R_0} \quad E_3 = \frac{\sin 2\alpha}{16} \left(\frac{1}{q^2} - \frac{1}{p^2} \right)$$

$$E_4 = \frac{E_3^2}{4E_2} (5 - \csc^2 \alpha) + E_2^3 \sec^2 \alpha \quad E_5 = \frac{E_3^3 (7 - 3 \csc^2 \alpha)}{4E_2^2} + 3E_2^2 E_3 \sec^2 \alpha$$

$$E_6 = \frac{E_3^4 (21 - 14 \csc^2 \alpha + \csc^4 \alpha)}{8E_2^3} + E_2 E_3^2 (7 - \csc^2 \alpha) \sec^2 \alpha + 2E_2^5 \sec^4 \alpha$$

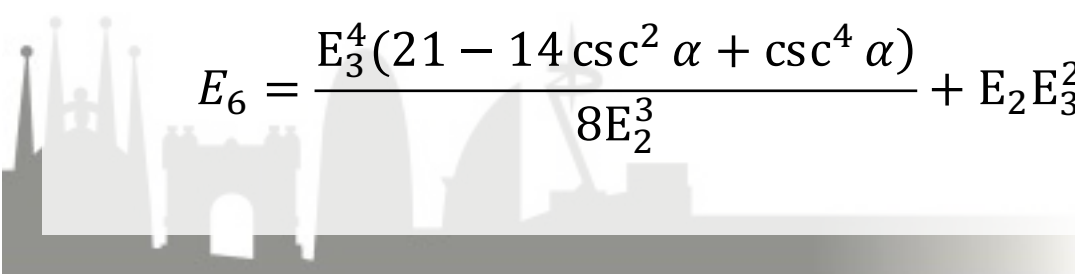

Aberrations, revisited

Defocus is given by the quadratic term of the ellipse polynomial

$$F_{20} = \frac{\cos^2 \alpha}{2} \left(\frac{1}{p} + \frac{1}{q} - \frac{2}{R \cos \alpha} \right) \longleftrightarrow F_{20} = 2 \cos \alpha \left[\frac{\cos \alpha}{4} \left(\frac{1}{p} + \frac{1}{q} \right) - \frac{1}{2R} \right]$$

Remember: $E_2 = \frac{\cos \alpha}{4} \left(\frac{1}{p} + \frac{1}{q} \right)$

$$F_{20} = 2 \cos \alpha \Delta E_2$$

Primary coma is given by the cubic term of the ellipse polynomial

$$F_{30} = \frac{\sin \alpha \cos^2 \alpha}{2} \left(\frac{1}{p} - \frac{1}{q} \right) \left(\frac{1}{p} + \frac{1}{q} - \frac{1}{R \cos \alpha} \right) \xrightarrow{\text{if } F_{20}=0} \longleftrightarrow F_{30} = -2 \cos \alpha \frac{\sin 2\alpha}{16} \left(\frac{1}{q^2} - \frac{1}{p^2} \right)$$

Remember: $E_3 = \frac{\sin 2\alpha}{16} \left(\frac{1}{q^2} - \frac{1}{p^2} \right)$

$$F_{30} = -2 \cos \alpha \Delta E_3$$





3. Mirror bender calculations and metrology

- *Euler-Bernoulli equation*
- *Rectangular footprint case*
- *Custom footprint case*

Elastic beam theory

Euler-Bernoulli equation

$$E \cdot I(x) \frac{d^2}{dx^2} z(x) = M(x)$$

- $z(x)$ is the deformation induced by the load. [m]
- $M(x)$ is the distribution of bending moments along the mirror
- E is the Young's modulus of the body. [N/m²]
- $I(x)$ is the second moment of inertia of the mirror substrate section. [m⁴]

Bending moments

$$M(x) = \sum_{i|x_i < x} (x - x_i) F_i$$

Second moment of inertia

$$I(x) = \iint_{\text{Section}} z^2 dx dz$$

For a rectangular section

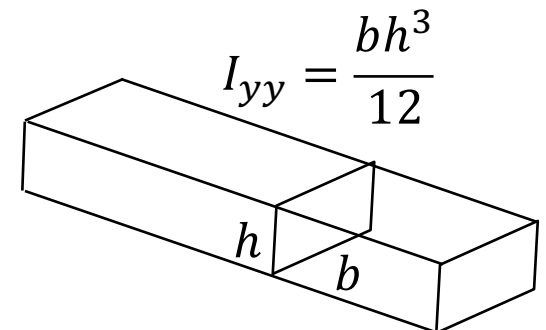

Integration (rectangular mirror footprint)

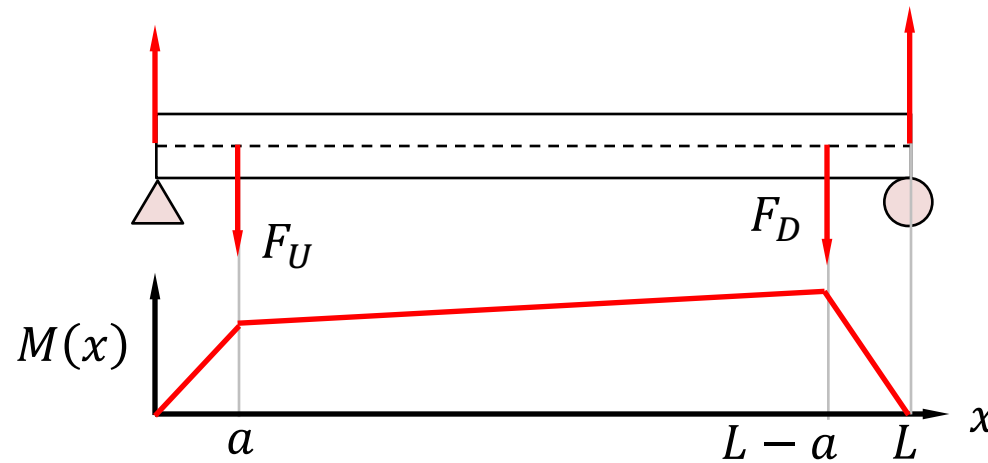

General Solution to Euler-Bernoulli' equation

$$z(x) = c_0 + c_1x + \int_{-L/2}^x \int_{-L/2}^{x''} \frac{M(x')}{E I(x')} dx' dx''$$

For constant section mirror the solution is a third degree polynomial

$$z(x) = c_0 + c_1x + E_2x^2 + E_3x^3$$

$$E_2 = \frac{3a}{Ebh^3} (F_U + F_D)$$

$$E_3 = \frac{2a}{Ebh^3L} (F_D - F_U)$$



Rectangular mirror footprint

$$E_2 = \frac{3a}{Ebh^3} (F_U + F_D)$$

$$E_3 = \frac{2a}{Ebh^3L} (F_D - F_U)$$

- The sum of forces **controls** the main curvature (and the defocusing)
- The difference between the forces **controls** the eccentricity (and primary coma)

$$\begin{pmatrix} E_2 \\ E_3 \end{pmatrix} = \begin{pmatrix} E_{2,INI} \\ E_{3,INI} \end{pmatrix} + \begin{pmatrix} E_{2U} & E_{2D} \\ E_{3U} & E_{3D} \end{pmatrix} \begin{pmatrix} F_U \\ F_D \end{pmatrix}$$

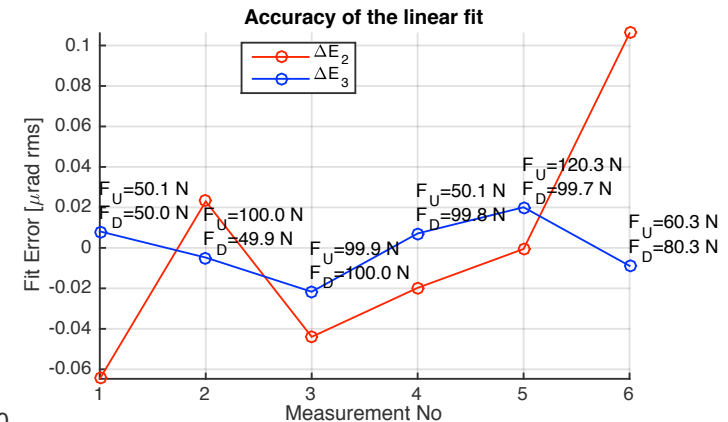
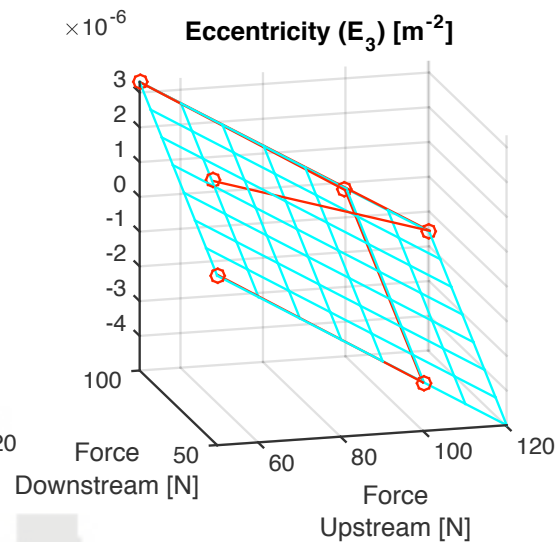
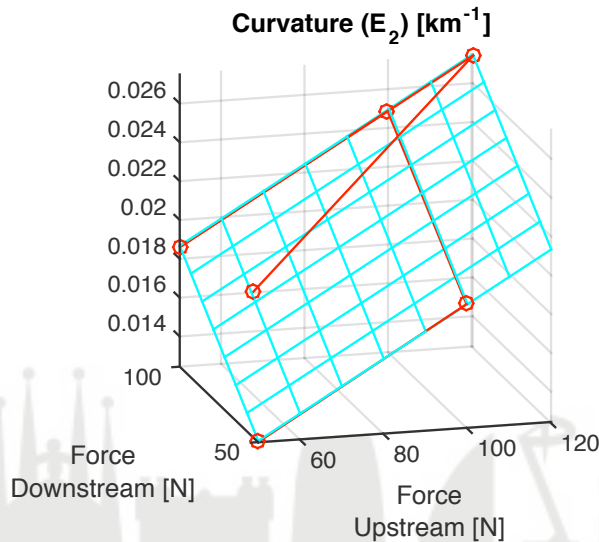

*fit better than about 50 nrad rms
(metrology limited – too quick)*

High demagnification ellipses

The error of the cubic polynomial approximation is given by:

$$y_{ERROR}(x) = y_{EXACT}(x) - E_2x^2 - E_3x^3$$

$$y_{ERROR}(x) = \frac{x(p^2 - q^2) \sin 2\alpha - 4(p + q) \cos \alpha (pq - \sqrt{pq} \sqrt{pq - x(p - q) \sin \alpha - x^2})}{p^2 + 6pq + q^2 - (p - q)^2 \cos 2\alpha} - \frac{\cos \alpha}{4} \left(\frac{1}{p} + \frac{1}{q} \right) x^2 - \frac{\sin 2\alpha}{16} \left(\frac{1}{q^2} - \frac{1}{p^2} \right) x^3$$

For high demagnification ellipses, higher order aberrations are significant

For ALBA's LOREA beamline HFM 10:1, 400 mm long, this error is in the order of 6.3 urad rms

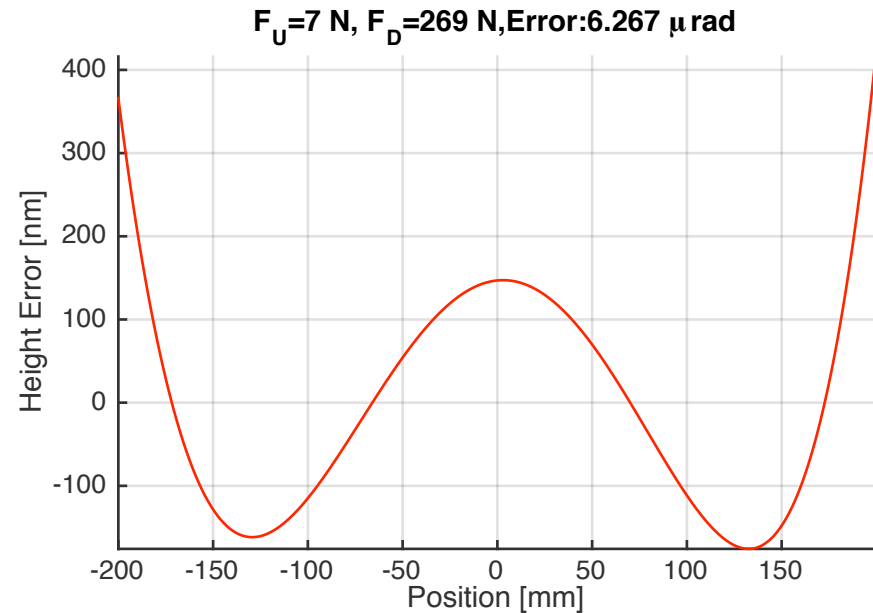

Varied width mirrors

Deformation equation includes curvature:

$$\frac{Eb(x)h^3}{12} \frac{d^2y}{dx^2}(x) = M_0 + \Delta M \frac{2x}{L}$$

$$M_0 = \frac{1}{2}(a_1F_1 + a_2F_2)$$

$$\Delta M = \frac{1}{2}(a_1F_1 - a_2F_2)$$

*By inserting the **exact** curvature profile, we have the definition of the required mirror width.*

$$\frac{Eb(x)h^3}{12} \frac{\sqrt{pq}(p+q)\cos\alpha}{2[pq - x(p-q)\sin\alpha - x^2]^{3/2}} = M_0 + \Delta M \frac{2x}{L}$$

The solution depends on the forces one can apply.

$$b(x) = b_0 \left(\frac{1}{b_0} M_0 + \frac{1}{b_0} \Delta M \frac{2x}{L} \right) \frac{24[pq - x(p-q)\sin\alpha - x^2]^{3/2}}{Eh^3\sqrt{pq}(p+q)\cos\alpha}$$

Often $b(x)$ is just approximated by a low order polynomial variation



Examples of varied profile mirrors

Mirror width profile for a 10:1 demagnification mirror, for different bending moment combinations.

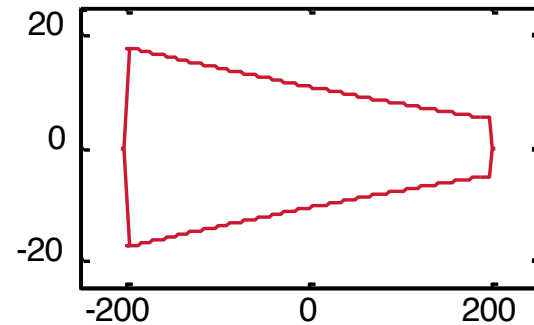
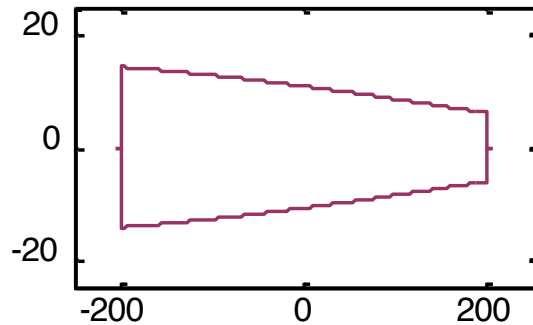
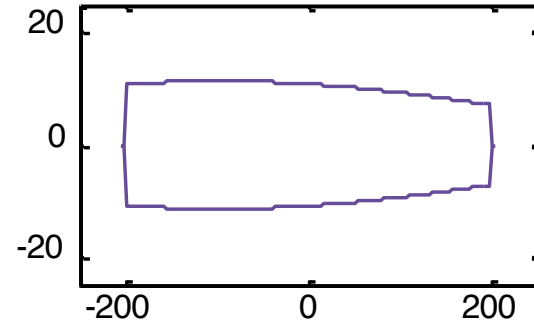
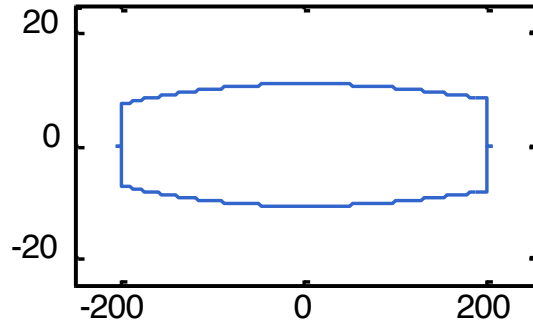

Model of deformation

Deformation of the mirror, in this case, is **NOT a polynomial**.

$$\frac{Eb(x)h^3}{12} \frac{d^2y}{dx^2}(x) = M_0 + \Delta M \frac{2x}{L}$$

$$\frac{Eb(x)h^3}{12} \frac{d^2y}{dx^2}(x) = a \left(\frac{x}{L} - \frac{1}{2} \right) F_U - a \left(\frac{x}{L} + \frac{1}{2} \right) F_D$$

... but it is still a **linear combination** of two functions.

$$y(x) = F_U y_U(x) + F_D y_D(x)$$

$$\begin{cases} \frac{Eb(x)h^3}{12a} \frac{d^2 y_U}{dx^2}(x) = \frac{x}{L} - \frac{1}{2} \\ \frac{Eb(x)h^3}{12a} \frac{d^2 y_D}{dx^2}(x) = -\frac{ax}{L} - \frac{1}{2} \end{cases}$$

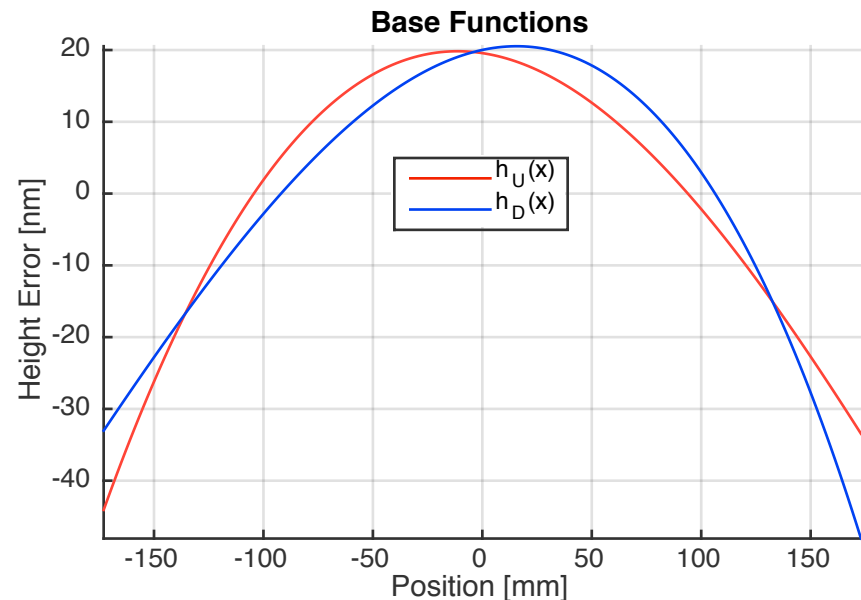

Metrology of varied width mirror benders

After fitting data to the proposed base of functions, residual figure (polishing error) is equal for all bending positions

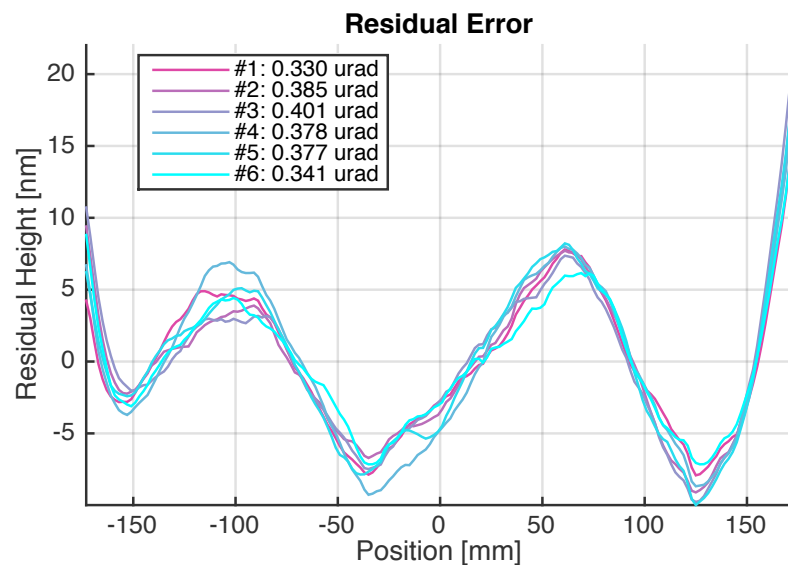
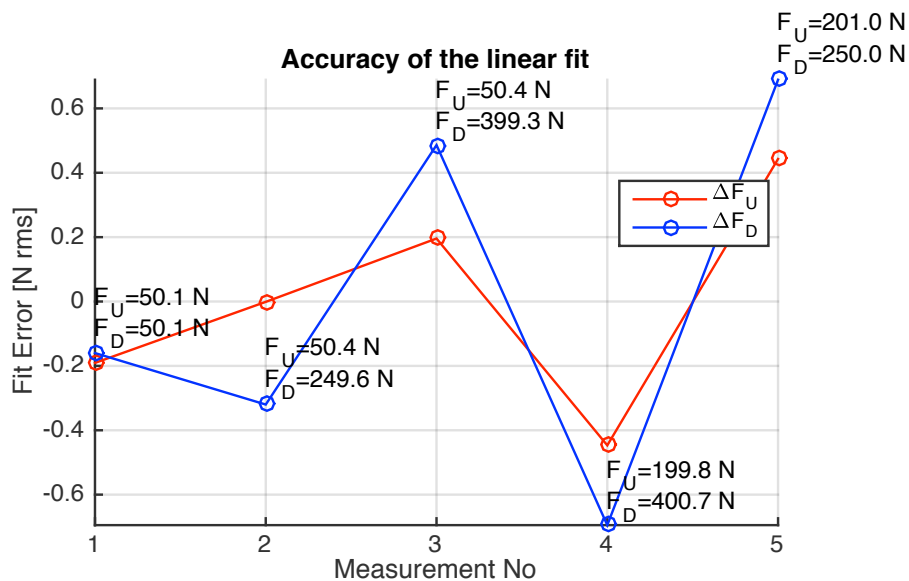



4. Mechanical design of mirror benders

- *Functionalities of bender*
- *Parasitic forces*
- *Cyl benders, U-type, 4-point, scissor, bimorph, ...*

A zoo of mechanical solutions

Cylindrical bender

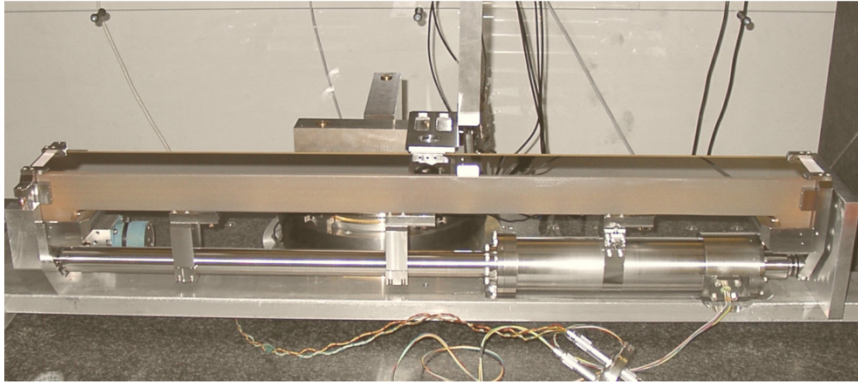

ESRF-Scissor bender

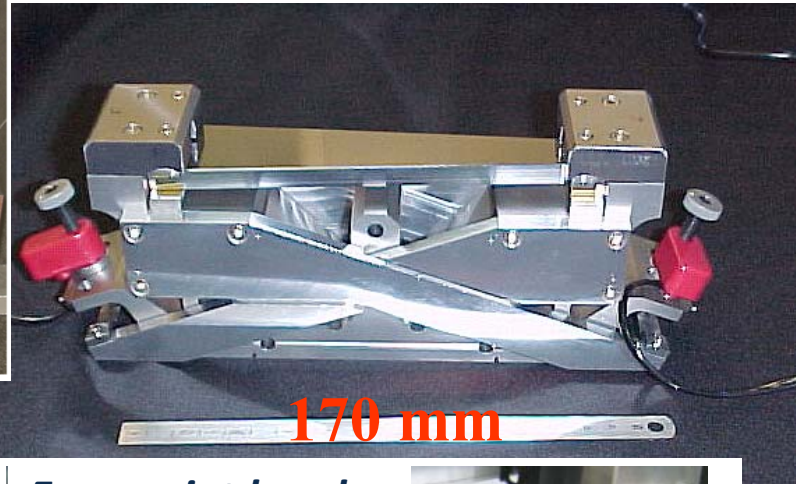

S-spring bender

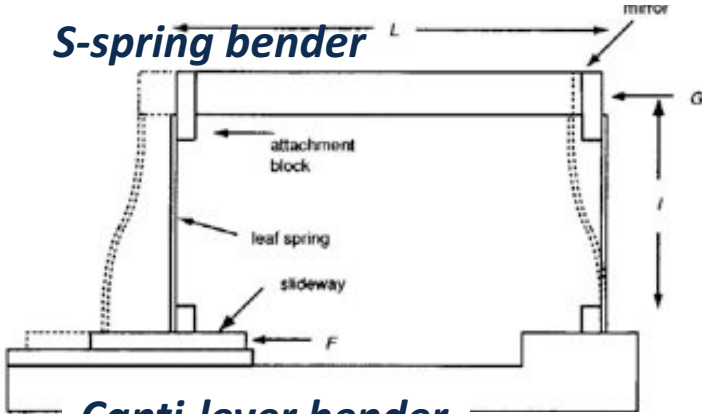

Four-point bender

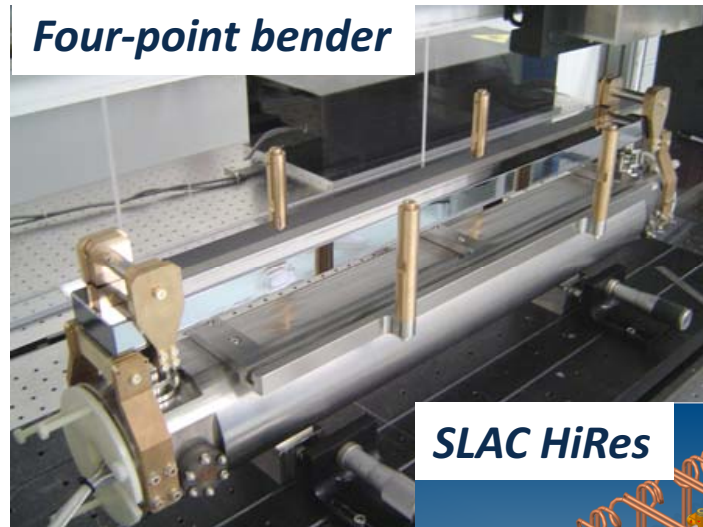

Canti-lever bender

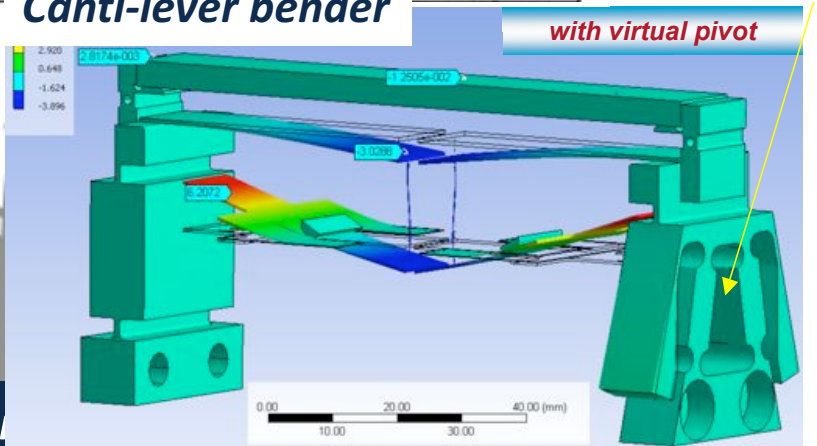

SLAC HiRes

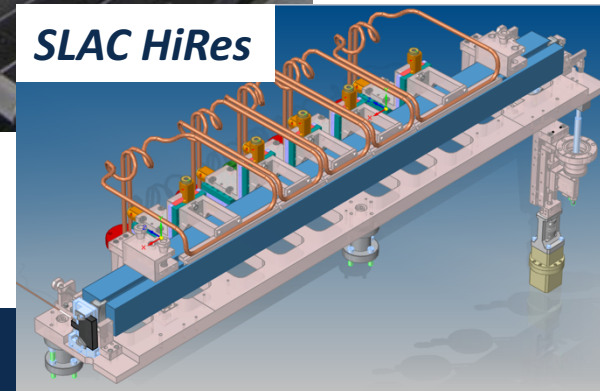

Mechanical design of benders

Functionalities of a bender

1. *To introduce the forces that deform the mirror to the required ellipse within tolerances.*
2. *To minimize parasitic forces that introduce undesired deformations*
3. *To introduce forces that deform the mirror to compensate gravity sag or other errors*



Mechanical design of benders

Functionalities of a bender

- 1. To introduce the forces that deform the mirror to the required ellipse within tolerances.**
 - 2. To minimize parasitic forces that introduce undesired deformations*
 - 3. To introduce forces that deform the mirror to compensate gravity sag or other errors*
- Fix the application point and direction**
 - Demagnify motor displacements to nanometer resolution deformation**



Apply controlled forces

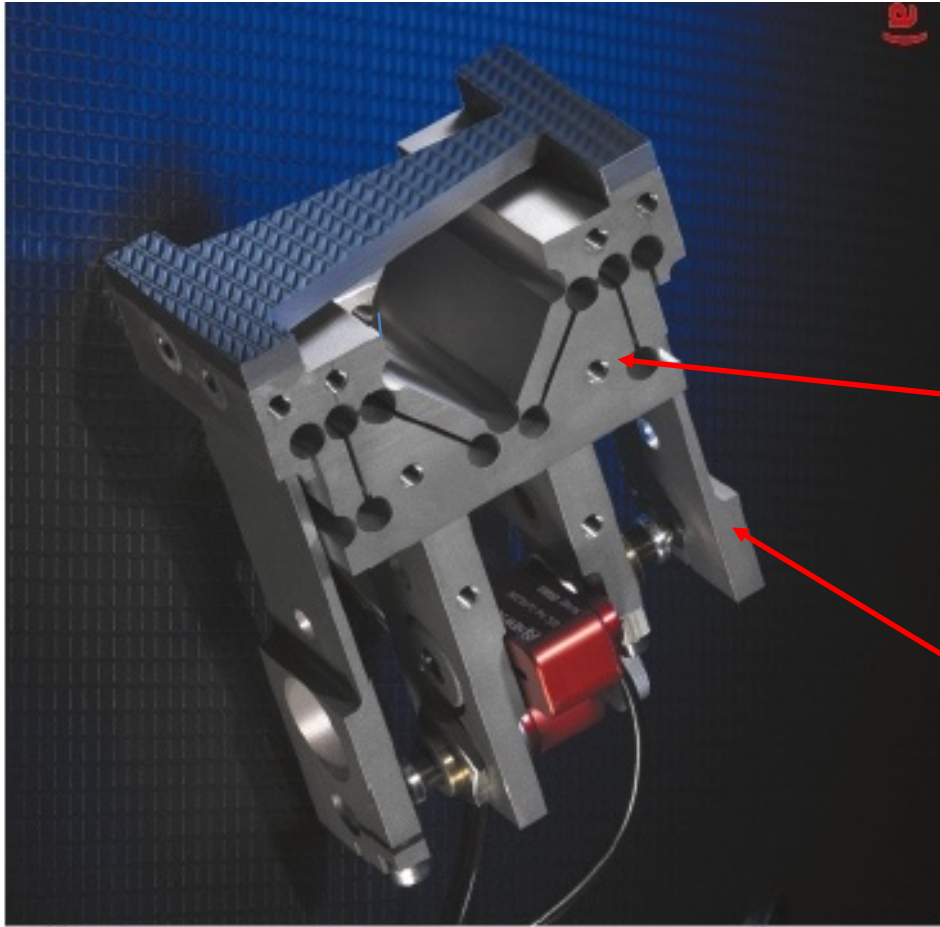

- *Fix the application point and direction*

- *Demagnify motor displacements to nanometer resolution deformation*

*Flexure hinges point to the “rotation” point.
Mirror is glued (monolithic)*

Lever (+bending ?) demagnifies motor linear motion to an angle constraint on the mirror ends.

Apply controlled forces

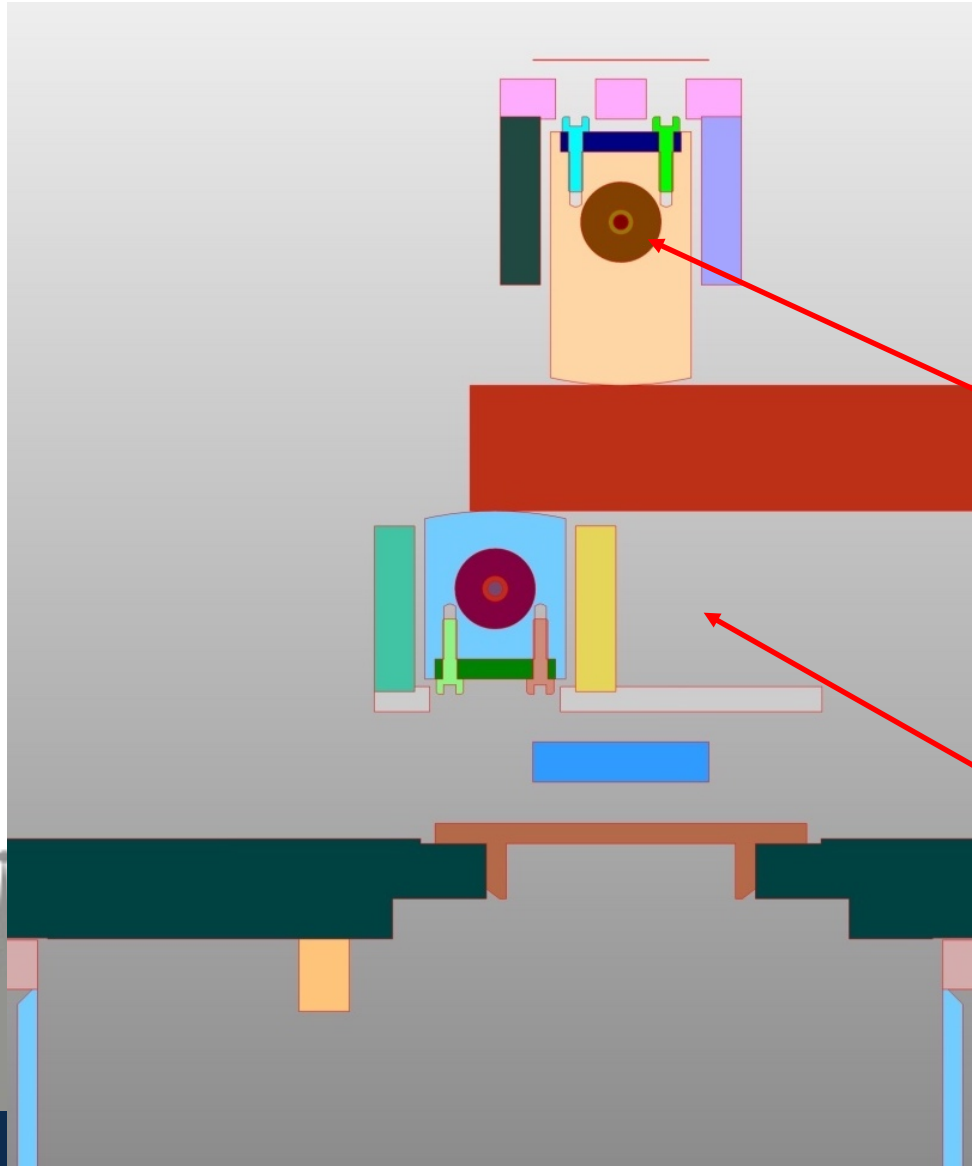

- *Fix the application point and direction*

- *Demagnify motor displacements to nanometer resolution deformation*

Pivot in center of contact surface ensures force is normal to the surface, and fixes application point

(Not visible) Force is exerted by a helicoidal spring in compression

Apply controlled forces

- *Fix the application point and direction*
- *Demagnify motor displacements to nanometer resolution deformation*

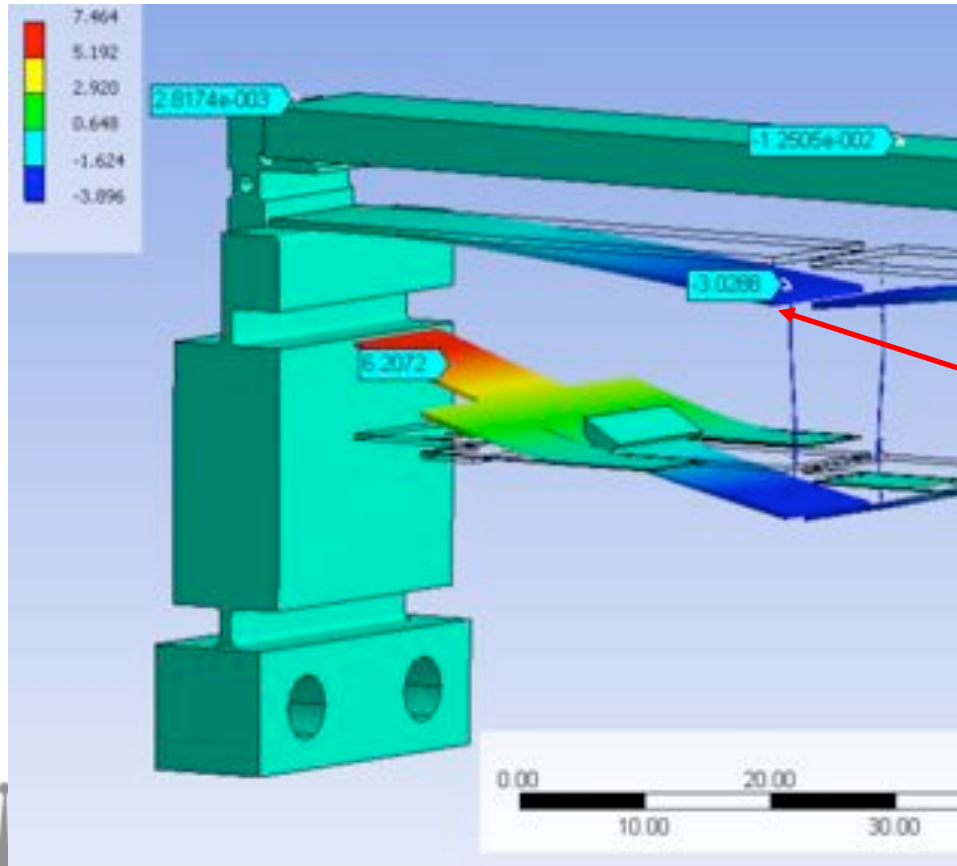

Demagnification of motor displacement by elastic bending of the cantilever

Apply controlled forces

- *Fix the application point and direction*
- *Demagnify motor displacements to nanometer resolution deformation*

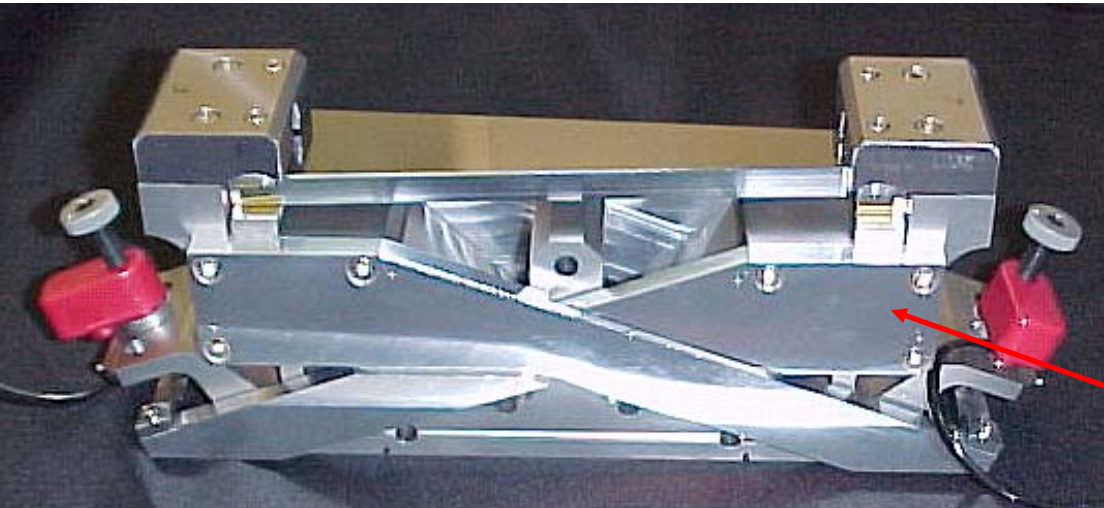

Demagnification of motor displacement by a rigid long lever arm



Mechanical design of benders

Functionalities of a bender

1. *To introduce the forces that deform the mirror to the required ellipse within tolerances.*
 2. *To minimize parasitic forces that introduce undesired deformations*
 3. *To introduce forces that deform the mirror to compensate gravity sag or other errors*
- ***Avoid twist***
 - ***Avoid forces along longitudinal axis***



Control parasitic forces

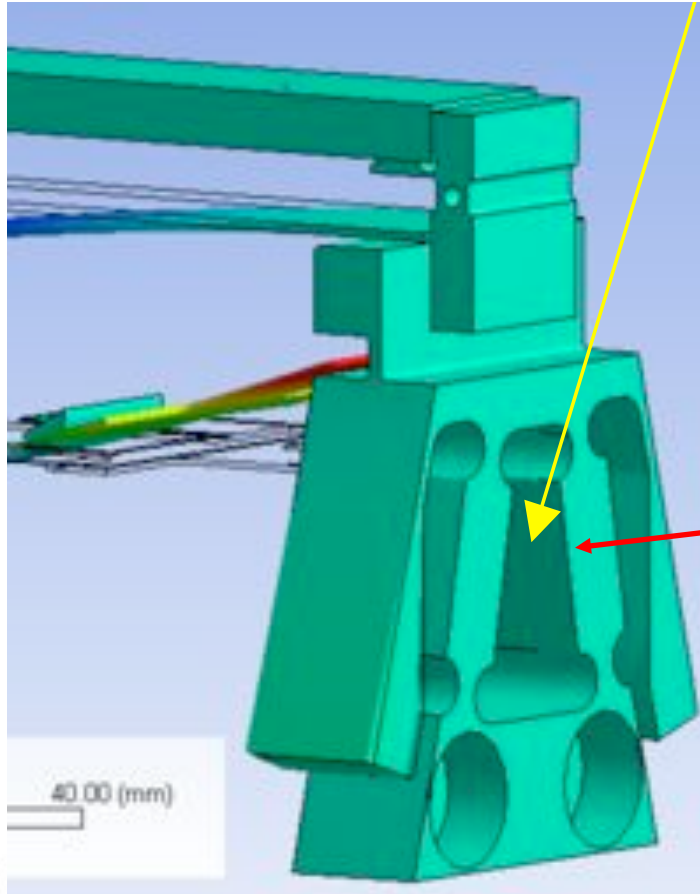

- *Avoid twist*
- *Avoid forces along longitudinal axis*

Virtual pivot to manually adjust the twist of one end of the mirror during metrology tests



Torsion (twist) adjustment

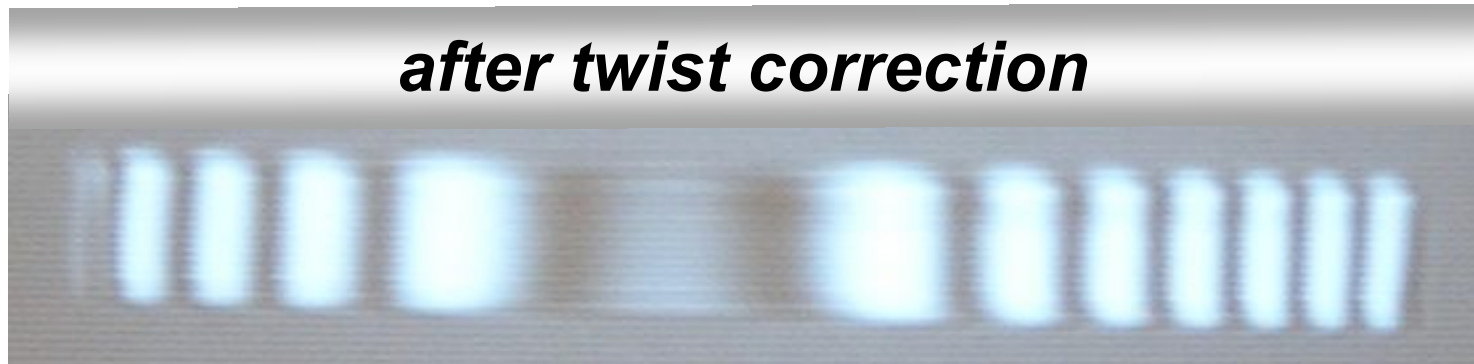
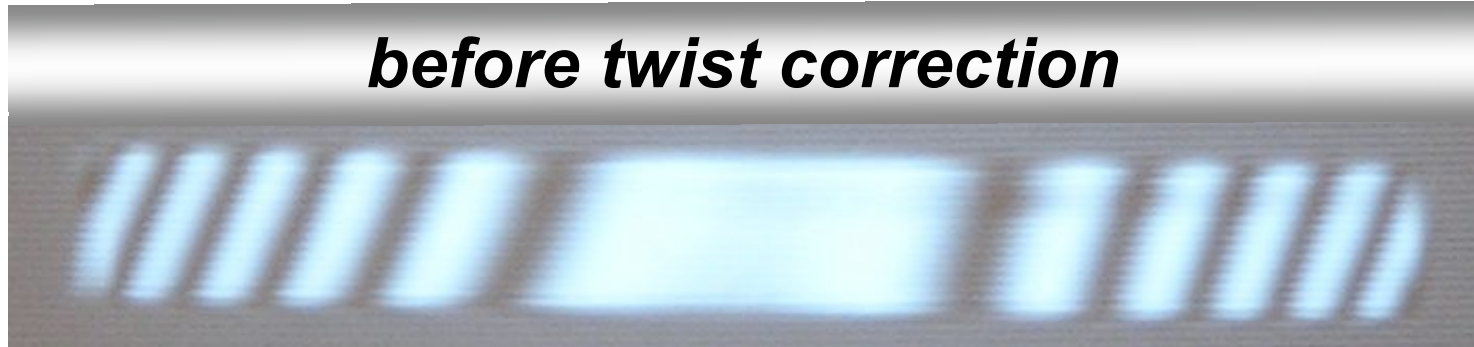

There are benders which are torsion free, and others which allow correcting it



Control parasitic forces

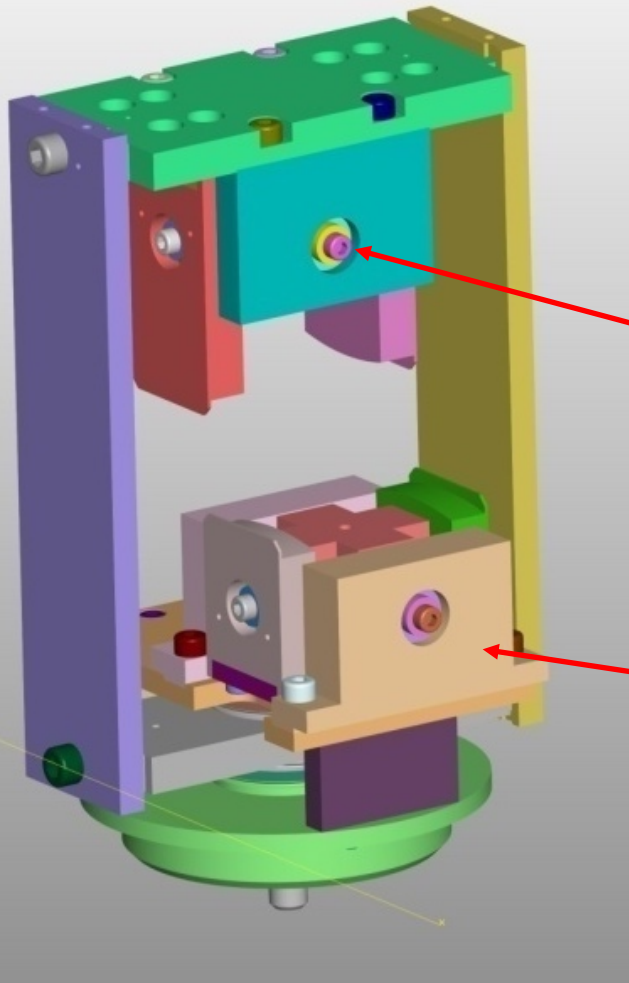

- *Avoid twist*
- *Avoid forces along longitudinal axis*

Bending force actuators allow pitch and roll to avoid introducing undesired deformations

Rolled articulation (on one side only) to allow the mirror settle its twist freely.



Mechanical design of benders

Functionalities of a bender

1. *To introduce the forces that deform the mirror to the required ellipse within tolerances.*
2. *To minimize parasitic forces that introduce undesired deformations*
3. ***To introduce forces that deform the mirror to compensate gravity sag or other errors***

- ***Gravity sag compensation***



Gravity sag compensation

- *Gravity sag compensation*

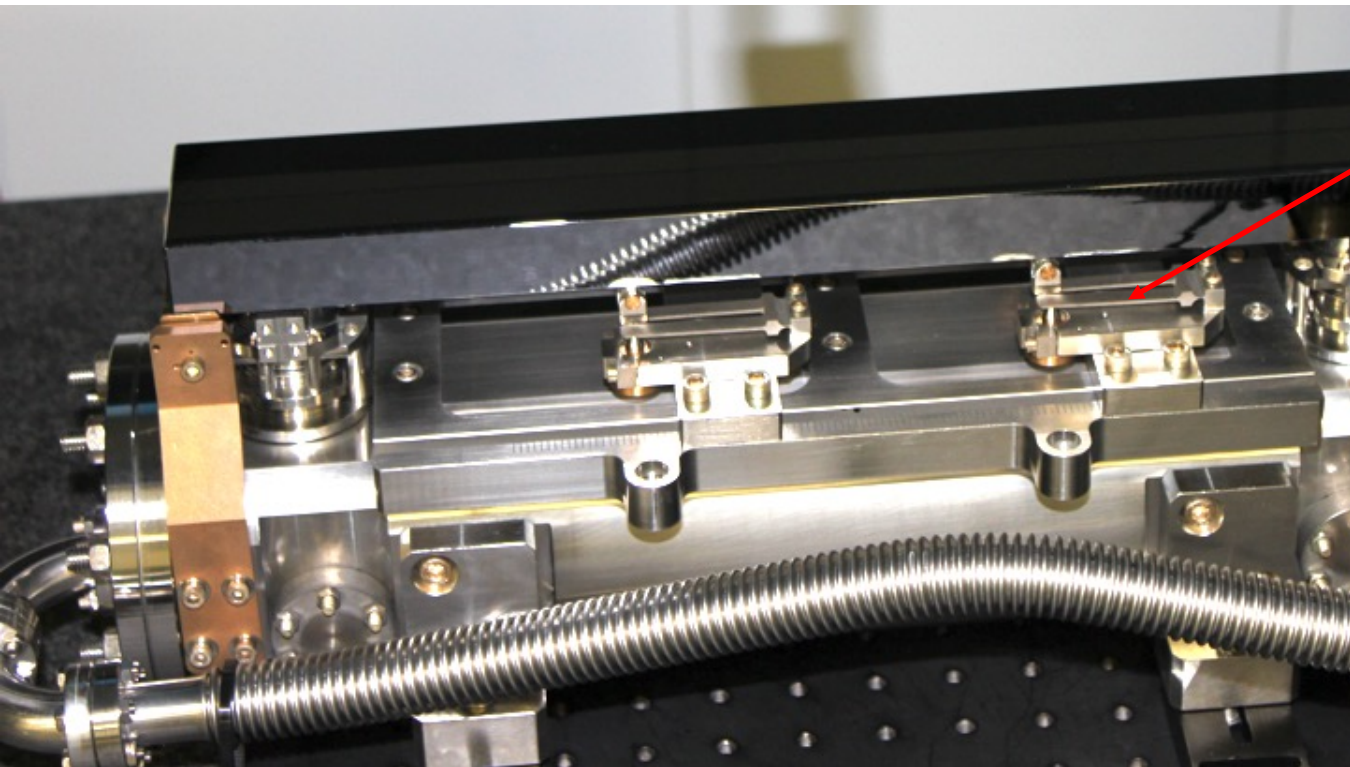

*Manually adjustable
springs, for gravity
sag compensation*



Adaptive optics

- Gravity sag compensation
- Adaptive optics

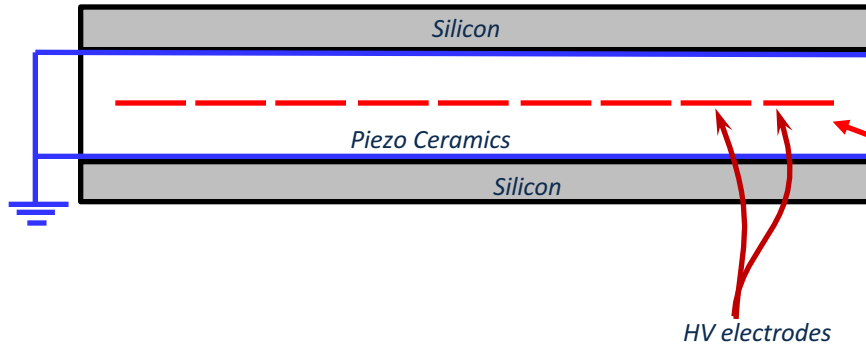

*Piezo – electric correctors
embedded in the mirror bulk*

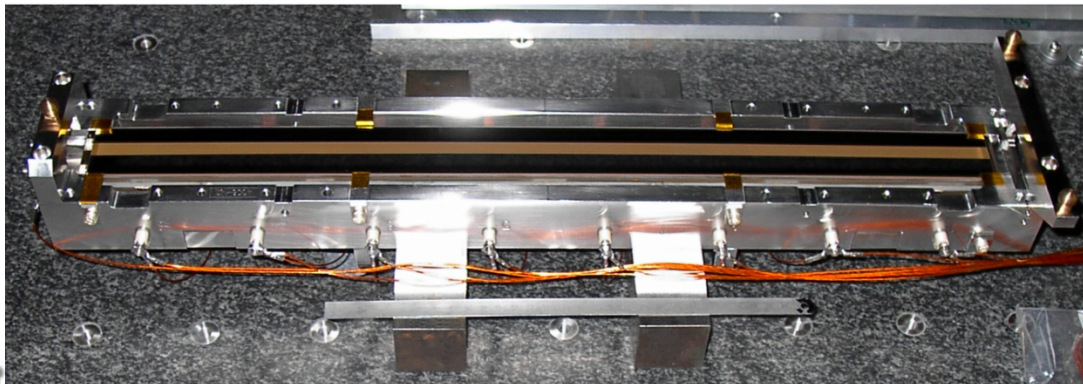

Adaptive optics

- *Gravity sag compensation*
- *Adaptive optics*

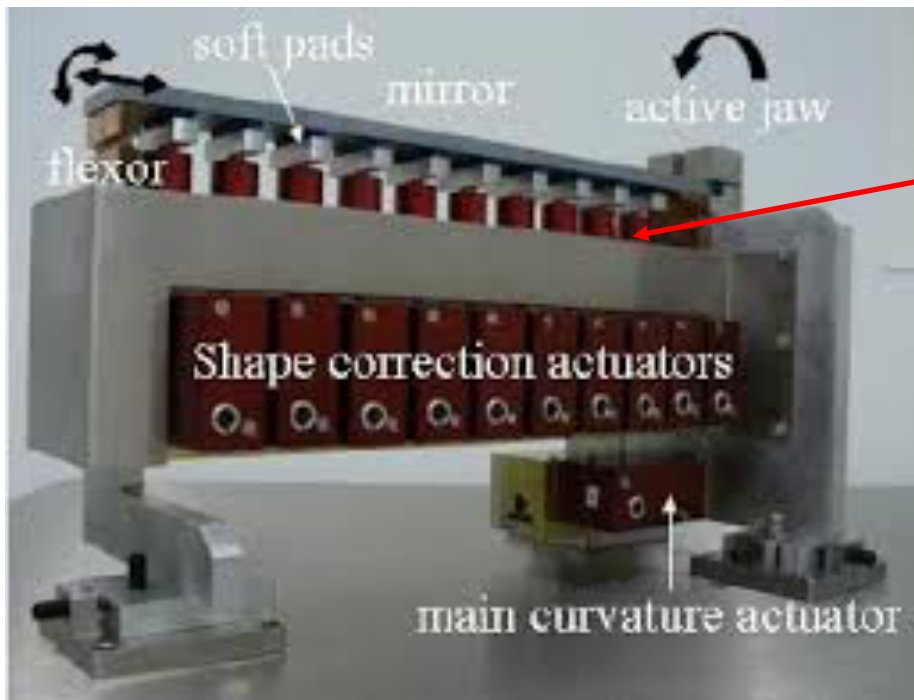

*Nanometer resolution –stiff-
pushing/pulling motors*



Adaptive optics

- *Gravity sag compensation*
- *Adaptive optics*

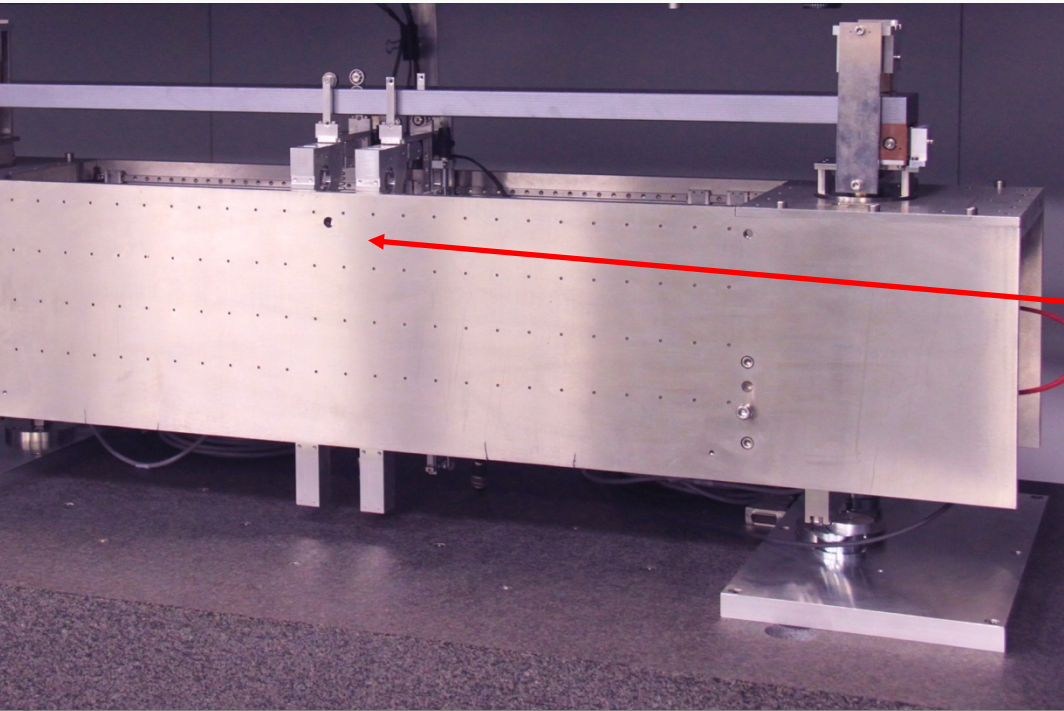

Force-stabilized – motorized correctors.



Adaptive optics

Results of the ALBA-SENER nanobender

Using 4 actuators, 500 mm

Initial slope error 0.87 μrad rms

Initial surface Error: 23.2 nm rms

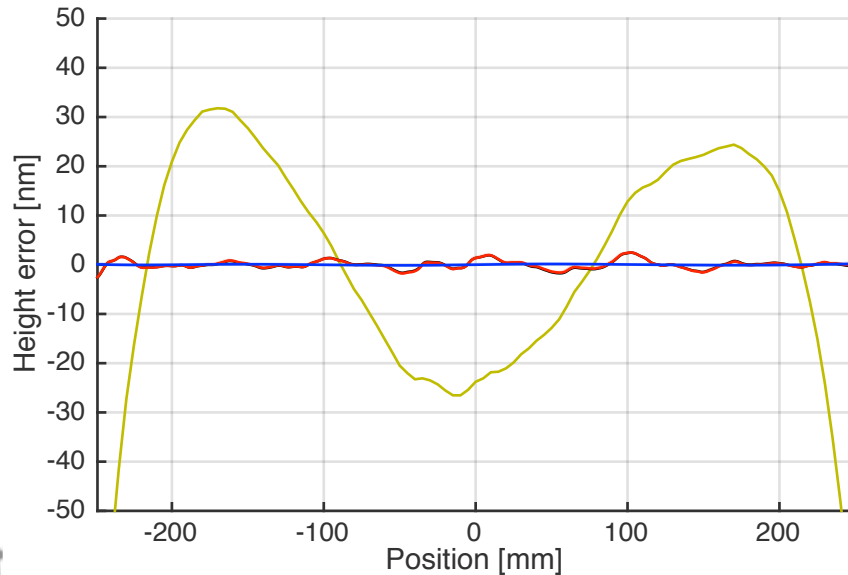

Slope Error: 0.115 μrad rms

Surface Error: 0.858 nm rms

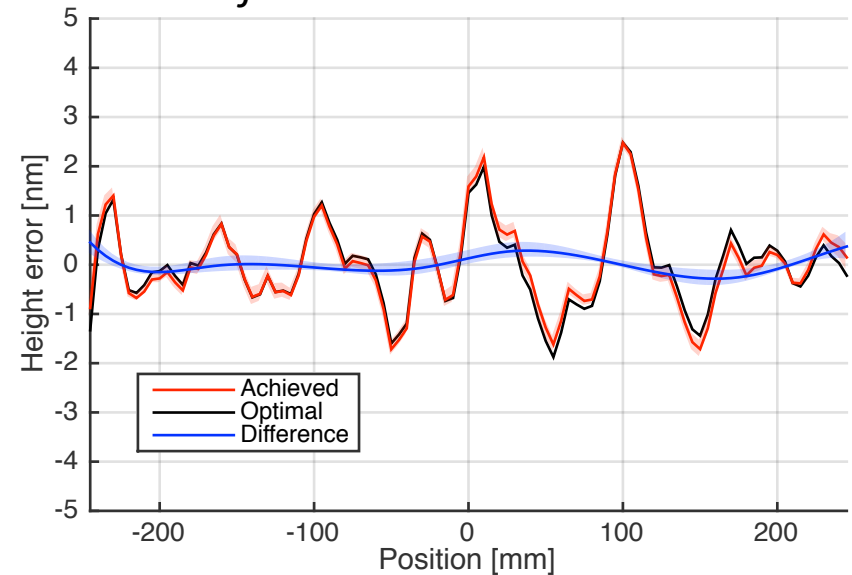

Difference to model-base optimum of 0.08 nm

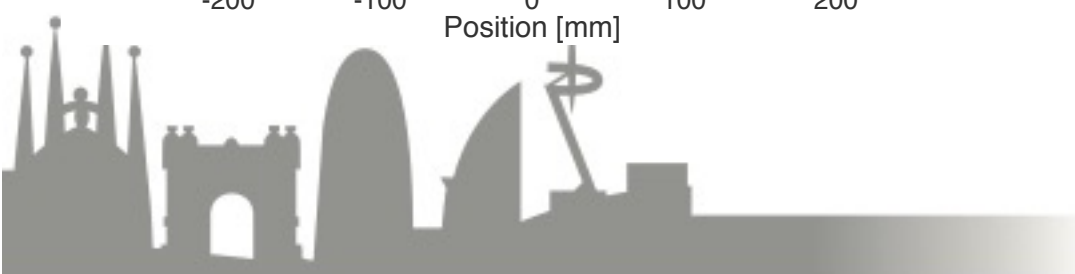

Adaptive optics

The correction is preserved within the nanometer with variations of the radius of curvature of 35% .

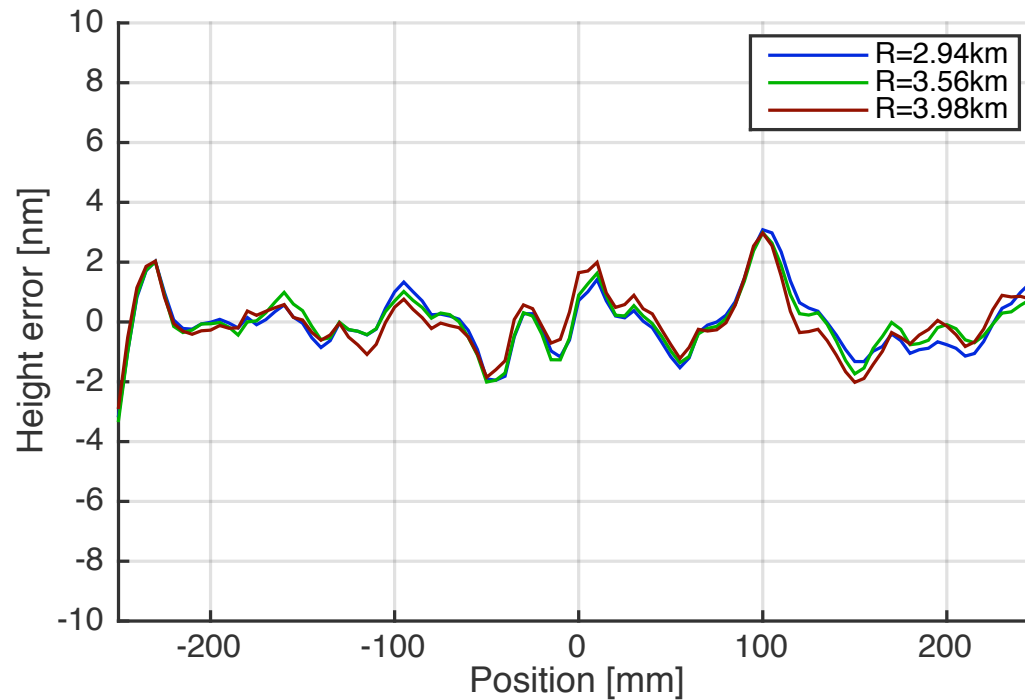



Acknowledgements

ALBA

Claude Ruget
Carles Collderam
Igors Sics
Pablo Pedreira

Valeriy Yashchuck (ALS)
Ray Barrett (ESRF)

SENER
IRELEC

SLAC

Daniele Cocco
Daniel Morton
Corey Hardin
May Ling Ng





Backup slides – gravity sag correction

- *Rectangular footprint case*
- *Custom footprint case*

Gravity sag calculation

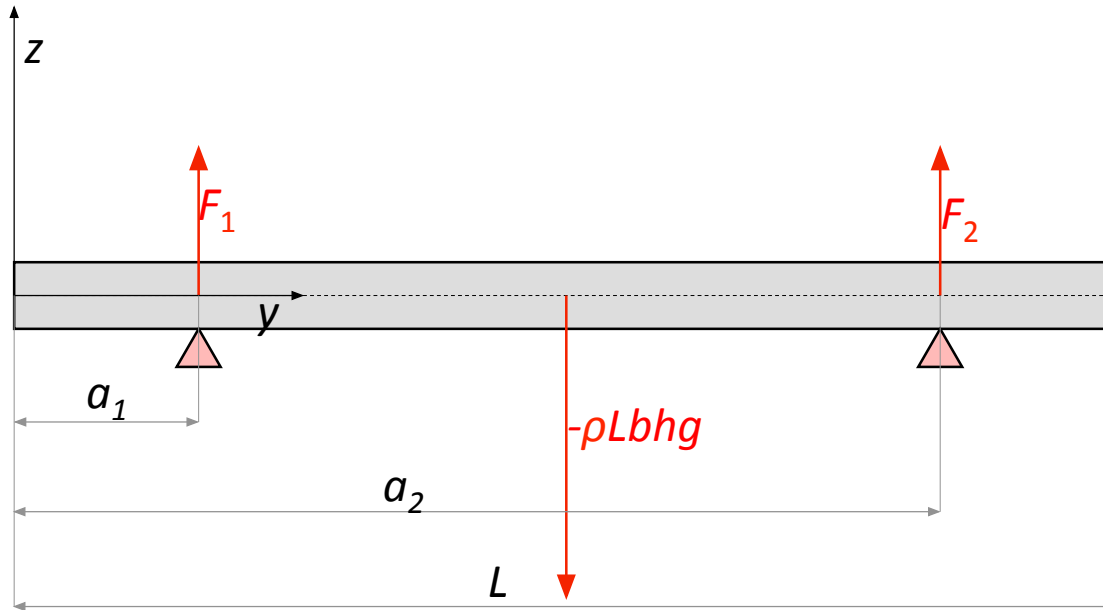

1. **Equilibrium of forces and torques:** to determine all the forces.
2. **Function of momenta:** to determine the RHS of the E-B equation.
3. **Integration.**
4. **Boundary conditions:** to determine the integration constants.



Equilibrium of forces

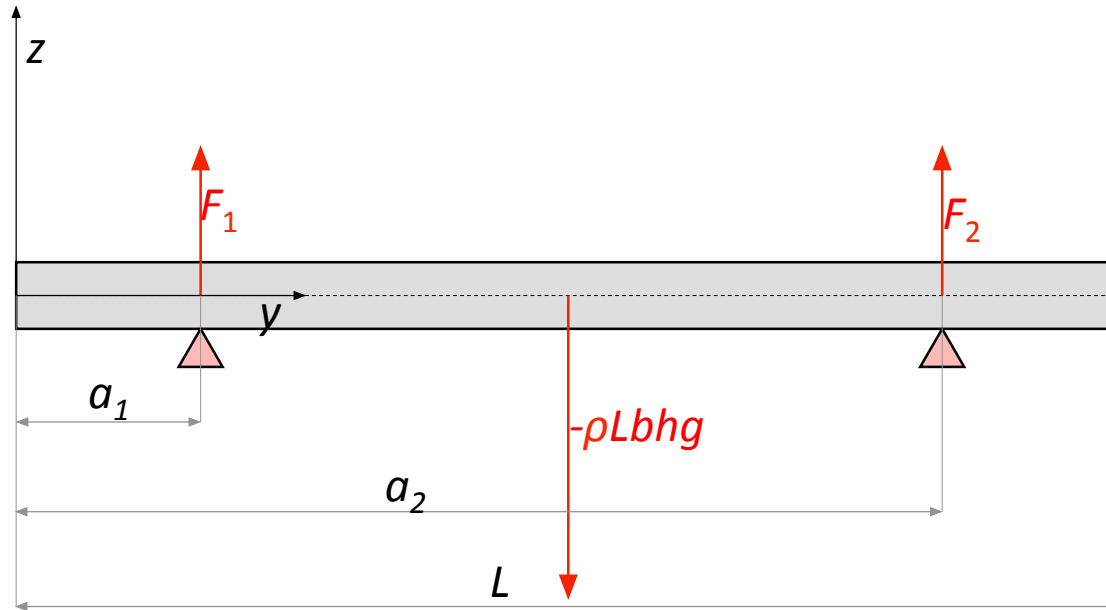

- All forces and torques must add to zero, otherwise the mirror would be accelerating linearly or angularly.
- Torques are calculated from the origin of coordinates (not the center of the mirror)

$$\begin{cases} F_1 + F_2 - g\rho Lbh = 0 \\ a_1 F_1 + a_2 F_2 - \frac{g\rho L^2 bh}{2} = 0 \end{cases}$$

$$F_1 = gm \frac{a_2 - L/2}{a_2 - a_1}$$

$$F_2 = gm \frac{L/2 - a_1}{a_2 - a_1}$$

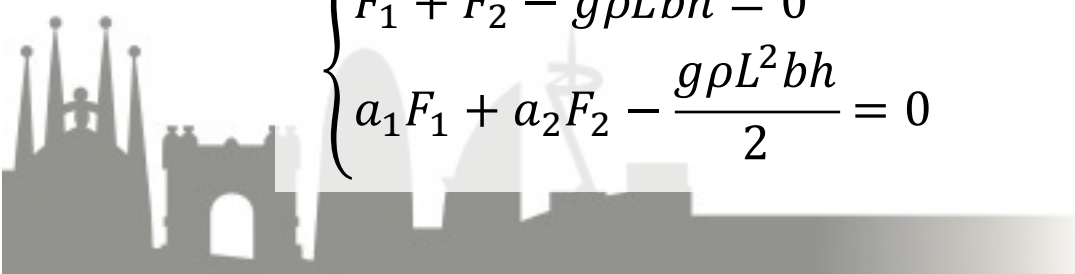

Function of moments

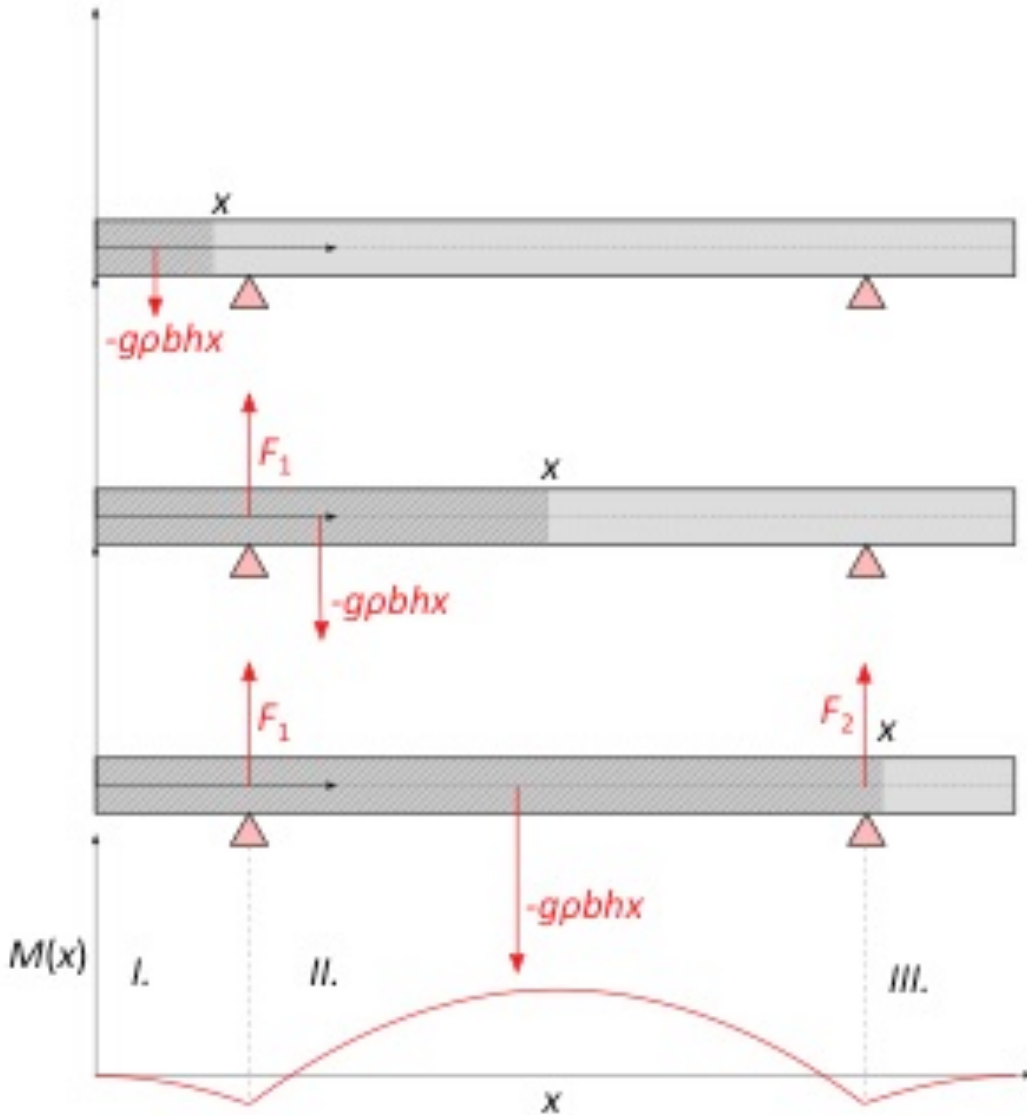

Region I. (only weight)

$$F_g(x) = -g\rho b h x$$

$$a_g(x) = \frac{x}{2}$$

$$M_I(x) = F_g(x) \left(x - a_g(x) \right)$$

$$= -\frac{1}{2} g\rho b h x^2$$

Function of moments

Region I. (only weight)

$$F_g(x) = -g\rho b h x$$

$$a_g(x) = \frac{x}{2}$$

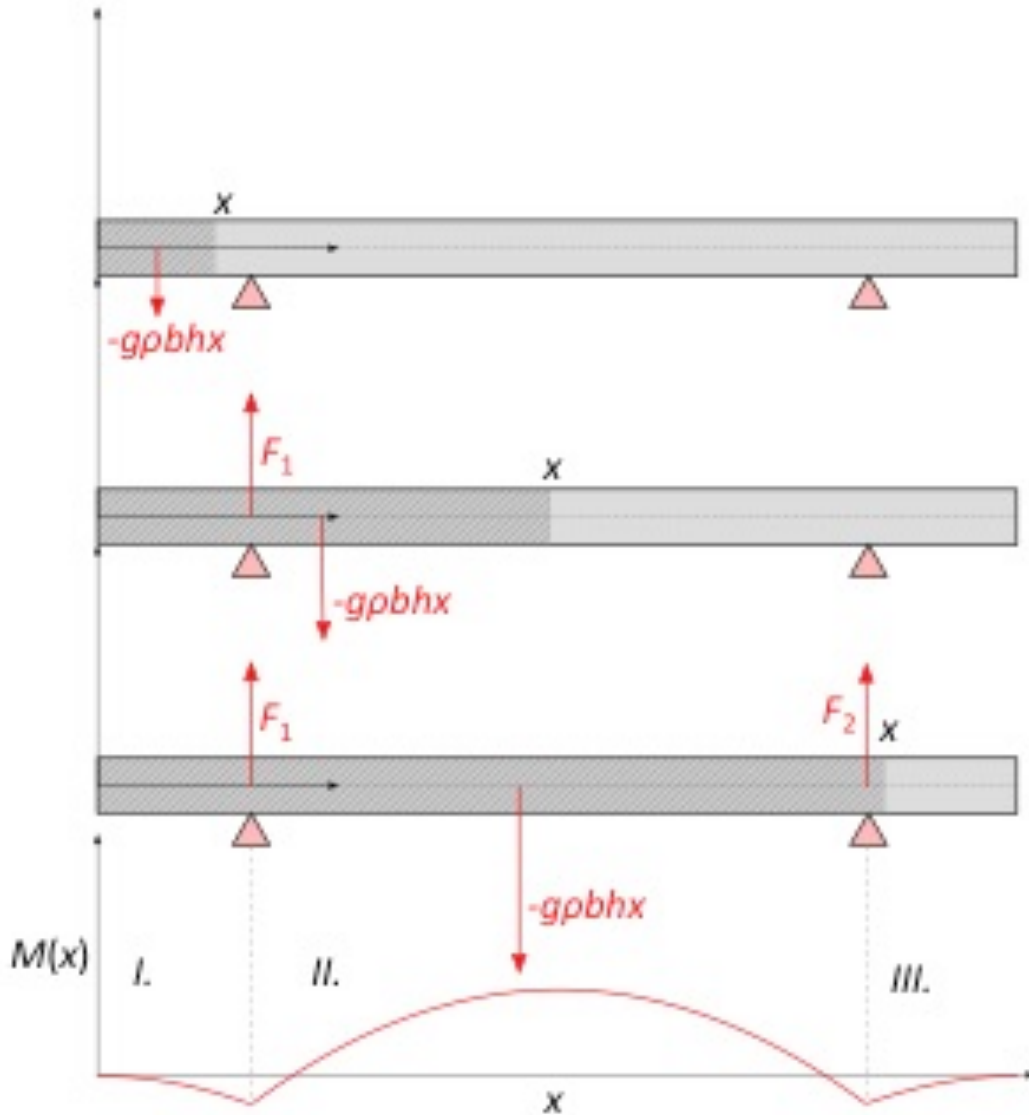

Function of moments

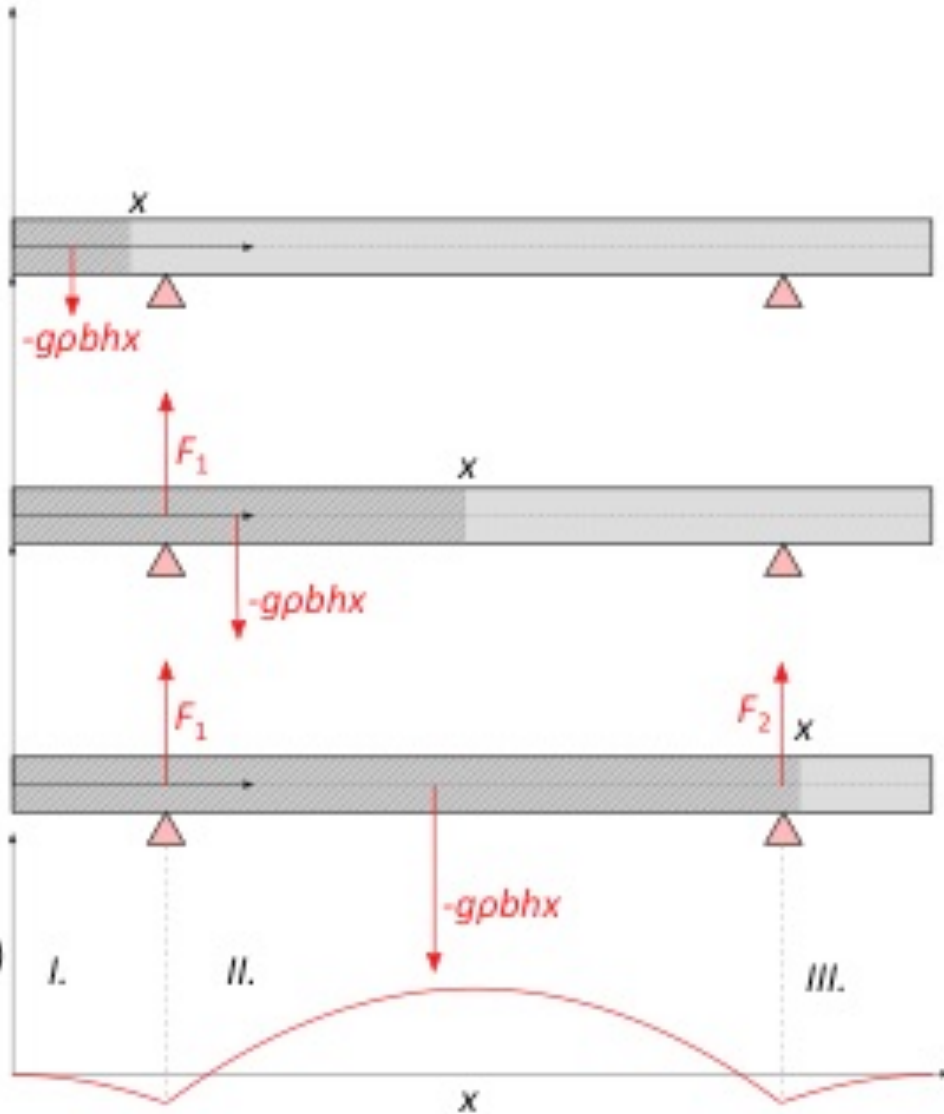

Region II. (weight, F_1)

$$M_{II}(x) = -\frac{1}{2}g\rho b h x^2 + F_1(x - a_1)$$

Region III. (weight, F_1 , F_2)

$$M_{III}(x) = -\frac{1}{2}g\rho b h x^2 + F_1(x - a_1) + F_2(x - a_2)$$

Integration (1)

- *Each region has to be integrated separately, because the function is not continuous.*
- *In all the cases the function of momenta is a polynomial of order 2. Which when integrated twice becomes a polynomial of order four.*

$$z_G(x) = z_0 + z_1x + z_2x^2 + z_3x^3 + z_4x^4$$

$$\frac{dz_G}{dx}(x) = z_1 + 2z_2x + 3z_3x^2 + 4z_4x^3$$

$$\frac{d^2z_G}{dx^2}(x) = 2z_2 + 6z_3x + 12z_4x^2$$

By defining :

$$k = \frac{Ebh^3}{12}$$

We have:

$$\frac{Ebh^3}{12} \frac{d^2z_G}{dx^2}(x) = 2kz_2 + 6kz_3x + 12kz_4x^2$$



Integration (2)

Notation change !!!

$$2kz_2 + 6kz_3x + 12kz_4x^2 = M(x)$$

$$z_i \rightarrow A_i, B_i, C_i$$

Region I.

$$M_I(x) = -\frac{1}{2}g\rho b h x^2$$

Implies

$$A_2 = 0$$

$$A_3 = 0$$

$$A_4 = -\frac{g\rho b h}{24k}$$

Unknown

$$A_0, A_1$$

Region II.

$$\begin{aligned} M_{II}(x) &= -a_1 F_1 + F_1 x \\ &\quad - \frac{1}{2} b g h x^2 \rho \end{aligned}$$

Implies

$$B_2 = -\frac{a_1 F_1}{2k}$$

$$B_3 = \frac{F_1}{6k}$$

$$B_4 = -\frac{b g h \rho}{24k}$$

Unknown

$$B_0, B_1$$

Region III.

$$\begin{aligned} M_{III}(x) &= (-a_1 F_1 - a_2 F_2) + (F_1 \\ &\quad + F_2)x - \frac{1}{2} b g h x^2 \rho \end{aligned}$$

Implies

$$C_2 = -\frac{a_1 F_1 + a_2 F_2}{2k}$$

$$C_3 = \frac{F_1 + F_2}{6k}$$

$$C_4 = -\frac{b g h \rho}{24k}$$

Unknown

$$C_0, C_1$$

Boundary conditions

1. Continuity between regions + at these points deformation is zero

$$z_I(a_1) = 0$$

$$z_{II}(a_1) = 0$$

$$z_{II}(a_2) = 0$$

$$z_{III}(a_2) = 0$$

2. Derivability (continuity of 1st derivative) between regions

$$z_I(a_1) = z_{II}(a_1)$$

$$z_{II}(a_2) = z_{III}(a_2)$$

The system is linear on $A_0, A_1, B_0, B_1, C_0, C_1$, and can be solved with unique solution (using Mathematica).

→ See Mathematica Notebook: **GravitySagCalculation.nb**



Example of gravity sag correction

A mirror measured with supports at the Bessel points and at the ends. Gravity sag is removed in both cases.

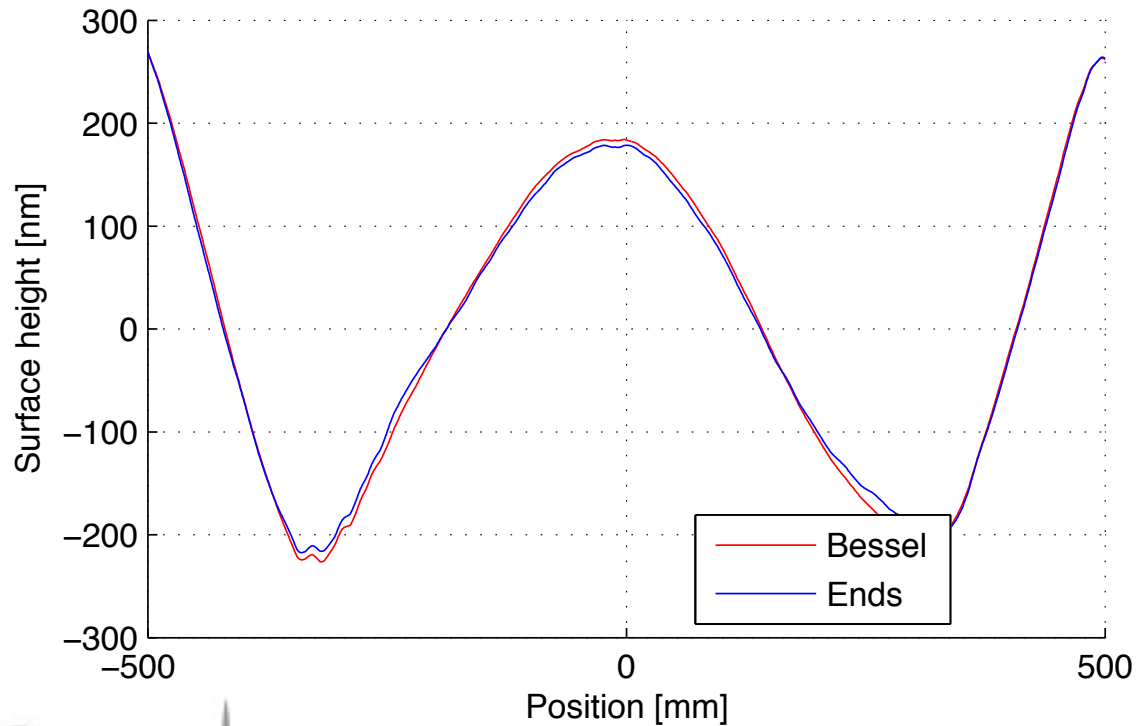

Gravity sag of arbitrary profile mirror

The width of the mirror is not constant

$$\frac{Eb(x)h^3}{12} \frac{d^2 z_G}{dx^2}(x) = M_G(x) + M_1(x) + M_2(x)$$

M_G : gravity, M_1 : support 1, M_2 : support 2

Calculating M_G

- Mass at the left of x : $m_L(x) = \rho h \left(\int_{-L/2}^x b(x') dx' \right) \quad I_0(x)$

- Mass center: $x_L(x) = \frac{\int_{-L/2}^x x' b(x') dx'}{\int_{-L/2}^x b(x') dx'} \quad \frac{I_1(x)}{I_0(x)}$

M_1, M_2

$$M_i(x) = [x - x_i] F_i \theta(x - x_i)$$

$\theta(x)$ Heavyside Step function



Gravity sag of arbitrary profile mirror

- *The width of the mirror is not constant.*

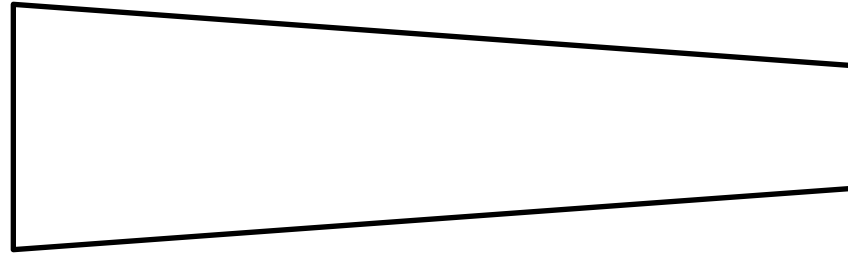

- *The equation is no-longer the integral of a polynomial.*

$$\frac{d^2 z_G}{dx^2}(x) = 12 \frac{M_G(x) + M_1(x) + M_2(x)}{Eb(x)h^3}$$

M_G: gravity, M₁: support 1, M₂: support 2

- *It can be integrated numerically.*
- *All the functions of x become vectors (linear arrays)*

$$f(x) \rightarrow f(x_n) \rightarrow f(n\Delta x) \rightarrow f_n$$



Moment of inertia of the weight

Calculating $M_G(x)$

- Mass at the left of x :
$$m_L(x) = \rho h \left(\int_{-L/2}^x b(x') dx' \right)$$

- Mass center:
$$x_L(x) = \frac{\int_{-L/2}^x x' b(x') dx'}{\int_{-L/2}^x b(x') dx'}$$

These become numerical integrals

$$(m_L)_n = \rho h \Delta x \sum_{m=1}^n b_m \quad (x_L)_n = \frac{\sum_{m=1}^n x_m b_m}{\sum_{m=1}^n b_m}$$

If you like you can apply more sophisticated integration methods, Simpson's rule, Spline,...

And the final expression of $M_G(x)$ is also a vector

$$M_G(x) = -g m_L(x) [x - x_L(x)]$$

$$(M_G)_n = -g (m_L)_n [x_n - (x_L)_n]$$

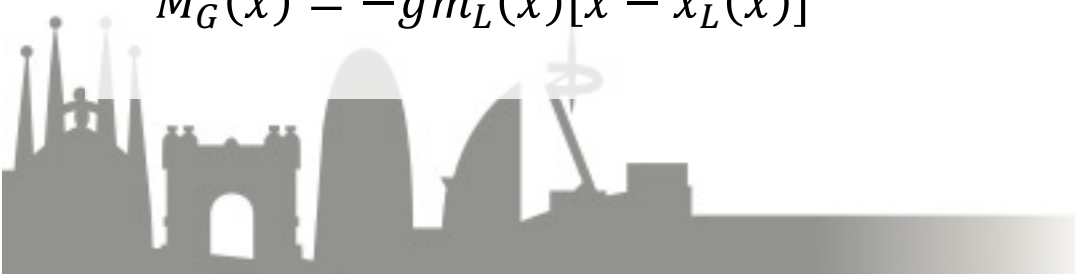

Moments of inertia of the supports

Calculating $M_1(x)$, $M_2(x)$

- Need to know the actual values of F_1 and F_2 (not just its expression as a function of mirror dimensions).

$$F_1 = gm_0 \frac{x_2 - x_0}{x_2 - x_1}$$

$$F_2 = gm_0 \frac{-x_1 + x_0}{x_2 - x_1}$$

m_0 : total mass

x_0 : mass center of the mirror

- They can be written in close expression using the Heaviside function step function

$$M_i(x) = (x - x_i)F_i\theta(x - x_i)$$

$$(M_i)_n = (x_n - x_i)F_i\theta(x_n - x_i)$$



Integration

- *Once all the functions of x are evaluated, they can be numerically integrated*
- *Note that, since we use close expressions, there are no boundary conditions between zones.*

$$z(x) = c_0 + c_1 x + \int_{-L/2}^x \int_{-L/2}^{x''} 12 \frac{M_G(x') + M_1(x') + M_2(x')}{Eh^3 b(x')} dx' dx''$$

- *Which becomes*

$$z_n = c_0 + c_1 x_n + \frac{12}{Eh^3} \sum_{m=1}^n \sum_{p=1}^m \frac{(M_G)_p + (M_1)_p + (M_2)_p}{b_p}$$

- *Average height and average pitch are undetermined. Often, these are simply set to average zero as they do not carry information about the mirror figure, but about its position.*

