

EXACT EQUILIBRIUM CURRENT SOLUTIONS FOR A SET OF LC COUPLED LOOP CIRCUITS WITH SECOND NEIGHBOUR COUPLING

by

S.O. Schriber  
Atomic Energy of Canada Limited  
Chalk River Nuclear Laboratories  
Chalk River, Ontario, Canada

Abstract

The treatment of second neighbour coupling in loop current solutions of the free oscillations of LC coupled loop circuits has usually been done using perturbation techniques. This paper gives the exact equilibrium solutions for these currents which are

$$i_n \propto \sin n\varphi + \alpha \cos n\varphi + \beta \sinh n\psi + \gamma \cosh n\psi$$

where

$$\cosh \psi = -\left(\cos \varphi + \frac{k_1}{2k_2}\right)$$

$k_1, k_2$  are the first and second neighbour coupling constants and  $\alpha, \beta, \gamma$  and  $\varphi$  are functions related to the coupled resonant mode and the termination of the system.

Relations for the  $\pi/2$  mode with  $k_2/k_1 \ll 1$  are given as well as the extrapolation of this method to many neighbour couplings. The solutions are useful for studying the effects of large second neighbour coupling and the effect second neighbour coupling has on the  $\pi/2$  mode particularly the detuning required for the first and last cells.

1. Introduction

The representation of a set of coupled rf resonators by a coupled-loop equivalent circuit has been very useful in predicting the behaviour of the physical system, in understanding its properties and in determining its tolerances (1). Tuning and assembly tolerances, unscrambling of information from the coupled mode spectra and relative cell field levels are among the most useful aspects for which the model has been used. The treatment of second neighbour coupling in the loop current solutions of the free oscillations of LC coupled loop circuits has usually been done using perturbation techniques. Exact equilibrium solutions for these currents are given below as well as a means of extrapolating this method to include many neighbour couplings.

2. Theory

2.1 Simple Second Neighbour Coupling

The coupled loop circuit analog used for a set of coupled resonators with all elements alike is shown in Fig. 1(a). The loop current relations for a system with N loops using Kirchoff's Law are

$$AKi_1 + i_2 + ci_3 = 0$$

$$Ki_2 + i_3 + i_1 + ci_4 = 0$$

⋮

$$Ki_n + i_{n+1} + c(i_{n+2} + i_{n-2}) = 0$$

⋮

$$Ki_{N-1} + i_N + i_{N-2} + ci_{N-3} = 0$$

$$AKi_N + i_{N-1} + ci_{N-2} = 0$$

$$\text{where } K = \frac{2}{k_1} \left(1 - \left(\frac{\omega_0}{\omega}\right)^2\right)$$

$i_n$  - current in the  $n^{\text{th}}$  loop

$\omega_0 = \sqrt{\frac{1}{2LC}}$  - the free oscillation frequency of each loop

$\omega$  - the free oscillation frequency of the coupled system

$$c = k_2/k_1$$

$k_1, k_2$  - first and second neighbour coupling constants

A - termination constant (full loop equivalent to full cell, = 1; half loop equivalent to shorted half cell, =  $\frac{1}{2}$ )

The treatment of a system with resistive losses requires the use of a complex form for K in the following treatment.

This set of equations can be solved using standard finite difference techniques leading to the  $n^{\text{th}}$  loop current equation

$$X^{n-2}(cX^4 + X^3 + KX^2 + X + C) = 0$$

when  $i_n$  is assumed to be of the form  $X^n$ .

Neglecting the trivial solution,  $X = 0$ , the symmetric quartic reduces to

$$(X^2 + LX + 1)(cX^2 + MX + c) = 0 \quad (1)$$

$$\text{with } Lc + M = 1 \text{ and } LM + 2c = K \quad (2)$$

The first bracketed term of equation (1) has solutions

$$X = \cos\varphi \pm j\sin\varphi \text{ with } L = -2 \cos\varphi$$

The frequency dispersion relationship is obtained by substituting  $L = -2\cos\varphi$  into equations (2) giving

$$\omega^2 = \frac{\omega_0^2}{1 + k_1 \cos\varphi + k_2 \cos 2\varphi} \quad (3)$$

The second bracketed term of equation (1) has solutions

$$X = e^\psi \pm e^{-\psi}$$

$$\text{where } \cosh\psi = -\left(\cos\varphi + \frac{k_1}{2k_2}\right)$$

The  $n^{\text{th}}$  loop current general solution is therefore given by

$$i_n = B(\sin n\varphi + \beta \sinh n\psi + \gamma \cosh n\psi) \quad (4)$$

where B is an arbitrary constant.

The solutions for  $\alpha$ ,  $\beta$ ,  $\gamma$  and  $\varphi$  are determined from the first two and the last two loop current equations. For a system terminated with full loops,  $A = 1$ , the parameters are given by

$$\left. \begin{aligned} \alpha &= \{ \sin\varphi \sinh(N+1)\psi - \sin(N+1)\varphi \sinh\psi \} / D \\ \beta &= \{ \sin(N+2)\varphi - \sin\varphi \cosh(N+1)\psi - \sin(N+1)\varphi \cosh\psi \} / D \\ \gamma &= \{ \sin(N+1)\varphi \sinh\psi - \sin\varphi \sinh(N+1)\psi \} / D \end{aligned} \right\} \quad (5)$$

$$\text{with } D = \cos\varphi \sinh(N+1)\psi + \cos(N+1)\varphi \sinh\psi - \sinh(N+2)\psi$$

$$\text{and } 0 = \left. \begin{aligned} f(\varphi) &= -\sin(N+1)\varphi \sinh(N+3)\psi + 2\sin(N+2)\varphi \sinh(N+2)\psi \\ &- \sin(N+3)\varphi \sinh(N+1)\psi - 2\sin\varphi \sinh\psi \end{aligned} \right\} \quad (6)$$

Solutions for  $\varphi$  which satisfy equation 6 are used in equations 5 to yield the parameters  $\alpha$ ,  $\beta$ ,  $\gamma$  needed by equation 4 to determine current solutions. The resonant frequency for this mode of operation is obtained by substituting  $\varphi$  into equation 3. Some simplifications of this complicated formula are possible when

$$c = \frac{k_2}{k_1} \ll 1. \text{ Here}$$

$$i_n = B \left( \sin n\varphi + c \sin\varphi \cos n\varphi - c \sin\varphi \left[ -\frac{c(1+\sin^2\varphi)}{2} \right]^n - (-c)^{N+1-n} \sin(N+1)\varphi \right)$$

$$\text{with } \varphi = \frac{\pi q}{N+1} \quad q = 1, 2, 3, \dots, N$$

Note that the addition of second neighbour coupling changes the current solutions from the simple  $\sin n\varphi$  form to terms involving  $k_2/k_1$ .

$$\text{For the } \pi/2 \text{ mode and } c = \frac{k_2}{k_1} \ll 1$$

the solutions reduce to

$$i_n = B \left( \sin \frac{n\pi}{2} + c \cos \frac{n\pi}{2} + (-c)^{n+1} \right)$$

which is not of the simple  $1, 0, -1, 0, 1, 0, -1, \dots$  form when  $k_2 = 0$ .

Without going into the details, the solutions for half loop terminated systems,  $A = \frac{1}{2}$ , can be solved in a similar

manner when  $c = \frac{k_2}{k_1} \ll 1$  giving

$$i_n = B \left( \sin n\varphi + \cot\varphi \left\{ \cos n\varphi - \left[ -\frac{c(1+\sin^2\varphi)}{2} \right]^n \right\} - (-c)^{N+1-n} \frac{\cos N\varphi}{\sin\varphi} \right)$$

$$\text{with } \varphi = \frac{\pi(q-1)}{(N-1)} \quad q = 1, 2, 3, \dots, N$$

$$\text{For the } \pi/2 \text{ mode and } c = \frac{k_2}{k_1} \ll 1$$

the solutions reduce to  $i_n = B \sin \frac{n\pi}{2}$ ,

identical to solutions with  $k_2 = 0$ . Even numbered loops have zero currents unlike that for the full loop terminated system shown above.

## 2.2 Different Second Neighbour Couplings

For second neighbour coupling,  $k_2$ , between odd numbered loops and  $k_2'$ , between even numbered loops, the following dispersion relationship and current solutions would result

$$i_n = B[\sin n\varphi + \alpha \cos n\varphi + \beta \sinh n\psi + \gamma \cosh n\psi]$$

where  $\alpha$ ,  $\beta$ ,  $\gamma$  and  $\varphi$  are determined from the first two and last two loop current equations.

$$B = R \text{ for odd numbered loops and } B = S \text{ for even numbered loops with}$$

$$\left( \frac{R}{S} \right)^2 = \frac{K + \frac{2k_2'}{k_1} \cos 2\varphi}{K + \frac{2k_2}{k_1} \cos 2\varphi}$$

$$\cosh \psi = \cos 2\varphi - k_1^2 \frac{\left[1 - \frac{(k_2 + k_2')K}{k_1}\right]}{2k_2 k_2'}$$

$$\text{and } \omega = \frac{\omega_0^2}{1 \mp \left(\frac{k_2 + k_2'}{2}\right) \cos 2\varphi \pm \sqrt{\left[\left(\frac{k_2 - k_2'}{2}\right) \cos 2\varphi\right]^2 + k_1^2 \cos^2 \varphi}}$$

With multiple couplings given by

$k_1, k_3, k_5, \dots$ ; first, third, fifth, --- neighbour coupling

$k_2, k_4, \dots$ ; second, fourth ---- neighbour coupling between odd numbered loops

$k_2', k_4', \dots$ ; second, fourth ---- neighbour coupling between even numbered loops

the dispersion relationship required to satisfy the coupled equations is

$$\omega^2 = \frac{2\omega_0^2}{E+F \pm \sqrt{(E-F)^2 + 4G^2}}$$

where  $E = 1 + k_2 \cos 2\varphi + k_4 \cos 4\varphi + \dots$

$F = 1 + k_2' \cos 2\varphi + k_4' \cos 4\varphi + \dots$

$G = k_1 \cos \varphi + k_3 \cos 3\varphi + k_5 \cos 5\varphi + \dots$

The current solutions for a multiply coupled system are difficult to solve.

### 2.3 Biperiodic System Coupling

The biperiodic system shown in Fig. 1(b) has all even numbered elements identical but different from the all identical odd numbered elements. The  $2n^{\text{th}}$  and  $2n+1^{\text{th}}$  loop current equations are

$$i_{2n} \left(1 - \frac{\omega_2^2}{\omega^2}\right) + \frac{k_1}{2} \sqrt{\frac{L_1}{L_2}} (i_{2n+1} + i_{2n-1}) + \frac{k_2'}{2} (i_{2n+2} + i_{2n-2}) = 0$$

$$i_{2n+1} \left(1 - \frac{\omega_1^2}{\omega^2}\right) + \frac{k_1}{2} \sqrt{\frac{L_2}{L_1}} (i_{2n+2} + i_{2n}) + \frac{k_2}{2} (i_{2n+3} + i_{2n-1}) = 0$$

where  $\omega_1 = \sqrt{\frac{1}{2L_1 C_1}}$  and  $\omega_2 = \sqrt{\frac{1}{2L_2 C_2}}$

Solving the set of N equations in a similar manner used in section 2.1 gives the following dispersion relationship

$$\omega^2 = \frac{a\omega_1^2 + b\omega_2^2 \pm \sqrt{(a\omega_1^2 - b\omega_2^2)^2 + 4\omega_1^2 \omega_2^2 k_1^2 \cos^2 \varphi}}{2(ab - k_1^2 \cos^2 \varphi)}$$

with  $a = 1 + k_2' \cos 2\varphi$ ;  $b = 1 + 2k_2 \cos 2\varphi$

and current solutions

$$i_n = B(\sin n\varphi + \alpha \cos n\varphi + \beta \sinh n\psi + \gamma \cosh n\psi)$$

where  $B = R$  for odd numbered loops and

$B = S \sqrt{\frac{L_1}{L_2}}$  for even numbered loops and

$$\left(\frac{R}{S}\right)^2 = \frac{K' + 2\frac{k_2'}{k_1} \cos 2\varphi}{K + 2\frac{k_2}{k_1} \cos 2\varphi}$$

with  $K' = \frac{2}{k_1} \left(1 - \left(\frac{\omega_2}{\omega}\right)^2\right)$ ;

$K = \frac{2}{k_1} \left(1 - \left(\frac{\omega_1}{\omega}\right)^2\right)$  and

$$\cosh \psi = \cos 2\varphi - \frac{k_1^2 \left[1 - \frac{k_2 K'}{k_1} - \frac{k_2' K}{k_1}\right]}{2k_2 2k_2'}$$

Some interesting simplifications of the above solutions are obtained when  $k_2' = 0$

(a) Half loop terminated system with  $k_2' = 0$

$$i_n = B \cos(n-1)\varphi \text{ with } \varphi = \frac{\pi(q-1)}{(N-1)}$$

$q = 1, 2, 3, \dots, N$

This is the same solution obtained with  $k_2 = 0$ . Second neighbour coupling between odd cells has the effect of shifting the resonance frequency but not the loop current amplitudes

(b) Full loop terminated system with  $k_2' = 0$

$$i_n = B \left[ \sin n\varphi - \frac{k_2 K' \sin \varphi \cos n\varphi}{k_1 \cos \varphi \left(2 - \frac{k_2 K'}{k_1}\right)} \right]$$

with  $0 = f(\varphi) = 4\cos^2 \varphi \sin(N+1)\varphi - \frac{k_2}{k_1} K' \cos \varphi \sin(N+2)\varphi + \left(\frac{k_2 K'}{k_1}\right)^2 \sin(N+3)\varphi$

This system is much more complicated than example (a). The complication is associated with breaking the system symmetry by using full loop termination.

(c) Full loop termination with  $k_2' = 0$  and

the end loops altered such that  $\omega_{\text{END}}^2 = \omega_1^2 + \frac{k_2}{2} \omega^2$ . By inspection of the first and last loop current equations this change preserves the symmetry of the system.

Here  $i_n = B \sin n\phi$  with  $\frac{\pi q}{N+1}$   $q=1,2,3,$   
 ----  $N$ , similar to the solutions with  $k_2=0$ .  
 To obtain a simple sine relation for the  
 loop currents, the end cells must be al-  
 tered by a different amount for each  
 mode. In particular for the  $\pi/2$  mode this  
 criterion requires

$$\omega_{END}^2 = \omega_1^2 \frac{(1-k_2/2)}{(1-k_2)}$$

If the end full cell of the physical  
 system were made up of two half cells,  
 the half cell without coupling to the  
 rest of the system would have to be  
 resonant at

$$\omega_{END}^2 = \frac{\omega_1^2}{1-k_2}$$

which is the coupled resonant  $\pi/2$  mode  
 for the entire system.

2.4 Multiple Coupling Biperiodic

The dispersion relationship  
 necessary to solve the set of coupled  
 equations involving multiple couplings  
 is given below using the same nomen-  
 clature as in section 2.2.

$$\omega^2 = \frac{F\omega_1^2 + E\omega_2^2 \pm \sqrt{(F\omega_1^2 - E\omega_2^2)^2 + 4\omega_1^2\omega_2^2G^2}}{2(EF - G^2)}$$

where  $F = 1 + k_2^2 \cos 2\phi + k_4^2 \cos 4\phi + \dots$   
 $E = 1 + k_2 \cos 2\phi + k_4 \cos 4\phi + \dots$   
 $G = k_1 \cos \phi + k_3 \cos 3\phi + \dots$

3. Conclusions

The dispersion relationships for  
 multiply coupled singly periodic and bi-  
 periodic systems have been given. The  
 current loop solutions for second  
 neighbour couplings have been given and  
 the relations for the  $\pi/2$  mode in parti-  
 cular have turned out to be simple. For  
 the biperiodic system operating in the  
 $\pi/2$  mode, if care is taken to alter the  
 frequency of the full end cells by

$$\omega_{END}^2 = \frac{\omega_1^2 (1-k_2/2)}{(1-k_2)}$$

then currents will be zero in even num-  
 bered loops for an idealized system and  
 equal in absolute amplitude in the odd  
 numbered loops.

References

- (1) E.A. Knapp, B.C. Knapp and J.M. Potter,  
 "Standing Wave High Energy Linear  
 Accelerator Structures" R.S.I. 39,  
 979, 1968.

(a) SINGLY PERIODIC SYSTEM

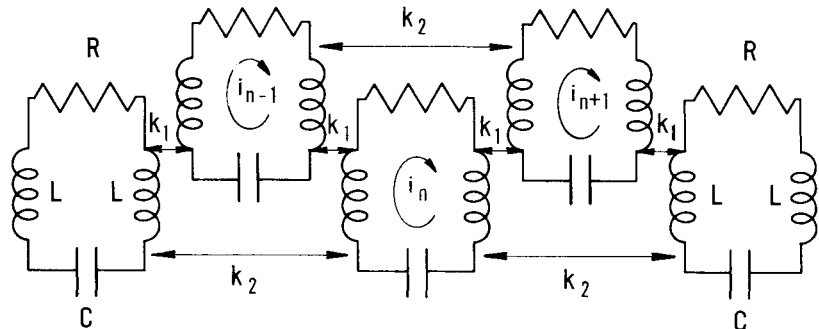

(b) BIPERIODIC SYSTEM

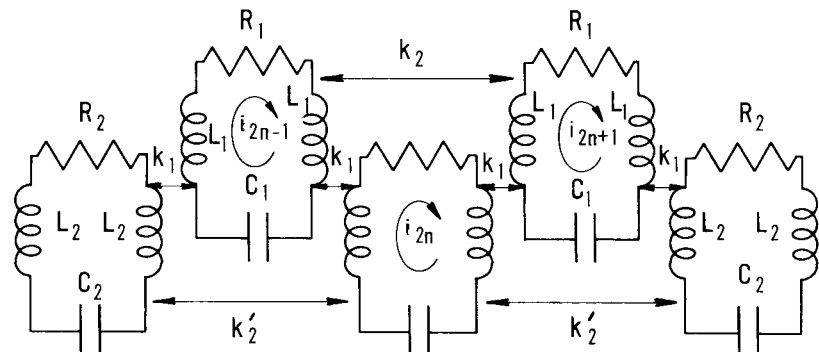

Fig. 1 RLC coupled loop circuit analog with  $k_1$   
 first neighbour coupling and  $k_2, k_2'$   
 second neighbour coupling. The singly

periodic system with all elements alike is shown  
 in (a) while (b) shows a biperiodic system with  
 alternate elements different.