

RIPPLE CURRENT AND FLUX IN MINERAL INSULATED MAGNETS*

Edward J. Schneider
University of California
Los Alamos Scientific Laboratory
Los Alamos, New Mexico

Abstract

A focusing or quadrupole magnet employing a solid iron core and wound with mineral-insulated (M.I.) conductor presents an impedance to the ripple voltage output of a power supply much different from the same magnet wound with a conventional-type conductor. This difference is due to the shorted-turn effect produced by the sheath of the M.I. conductor. Although its impedance is different, the attenuation of the ripple flux caused by the ripple current vs frequency appears to be of the same order as that of a similar magnet wound with a conventional-type conductor. This paper will present experimental data illustrating the above effect.

The effective shorted turn produced by the sheath or outer covering of the mineral-insulated conductor used in the coils of radiation-hard magnets gives the magnet a different impedance vs frequency characteristic than that of a magnet wound with a conventional conductor.

The purpose of the discussion is to compare two nearly identical magnets with the exception that one is wound with a conventional-type conductor while the other is wound with mineral-insulated conductor. Figure 1 shows two quadrupole magnets which have an 8 in. bore diameter and an iron length of 16 in. Magnet 8Q16MK1 has 39 turns per coil while the 8QN16M/7 has 41 turns per coil. The 8Q16MK1 magnet is wound with a 0.530 in. square conductor with a 0.219 in. diameter water hole. The 8QN16M/7 is wound with a mineral-insulated conductor with a cross section as shown in Fig. 2. Figure 3 is a block diagram of the test setup used to measure the impedance and ripple flux in the magnets over the frequency range of 0.02 Hz to 10 kHz. Special note should be made of the non-inductive shunt. Remarks concerning the signal from this shunt and the signal from conventional meter-type shunt will be made later.

Figure 4 shows the impedance vs frequency of the two magnets. The behavior of the magnet wound with the mineral-insulated conductor in the frequency range between 5 Hz and 400 Hz can be explained by thinking of the sheath of the mineral-insulated conductor as forming a shorted turn. Thus, the magnet can be pictured as a transformer whose secondary is

a shorted turn.

The ac component of the voltage applied to the magnet coils (consider this the primary) will induce a voltage in the shorted turn (consider this the secondary). The resulting secondary amp turns must be canceled by current drawn by the primary. As a result, the current drawn by the primary is in phase with the voltage. One must view this current as a load current of a transformer and not the exciting current of a transformer. The zero phase shift between the current and voltage in this frequency range, shown in Fig. 5, supports this explanation. In the frequency range between 0.1 Hz and 0.5 Hz, the magnet exhibits an inductance effect. Figure 4 shows the impedance changing from its dc value and Fig. 5 shows phase shift between the applied voltage and current. At about 500 Hz, this magnet again begins to look like an inductive circuit. The impedance of the 8Q16MK1 magnet and the phase shift between the applied ac voltage and current are also shown in Figs. 4 and 5. This magnet exhibits the properties of an inductive circuit throughout the frequency range tested.

This now raises the question: Is the ripple flux in the two magnets different for the same applied ac modulation of the dc voltage? Figures 6 and 7 show the ripple flux vs frequency for a constant applied ac voltage modulation on both magnets. These data were taken by measuring the pick-up voltage on a ten-turn coil set into the air gap so as to link the flux between two adjacent poles. Lenz's

*Work performed under the auspices of the United States Atomic Energy Commission.

Law, which states $e = N \frac{d\phi}{dt}$, may be integrated to yield

$$\phi = \frac{E_{\max}}{N\omega} \cos \omega t$$

when the voltage, e , is given as $E_{\max} \sin \omega t$. E_{pp} is twice E_{\max} ; thus, the maximum flux can be written

$$\phi_{\max} = \frac{E_{pp}}{2\omega N} \text{ (Maxwell units).}$$

The number of ripple flux lines (Maxwells) at the very low frequency (0.02 Hz) end of the curve should agree between the two magnets if we account for the different number of turns between the two magnets and the different modulation current which flowed in the two magnets due to the $2 V_{pp}$ voltage modulation. Magnet 8Q16MK1 indicates 10^5 Maxwells. The modulated current was recorded to be 78.9 A for the $2 V_{pp}$ voltage modulation at this frequency. On magnet 8Q16M/7, the modulated current was recorded to be 25.7 A for the $2 V_{pp}$ voltage modulation at this same frequency. Using the 10^5 Maxwells measured on magnet 8Q16MK1 to predict the equivalent point on the 8Q16M/7, we get

$$10^5 \times \frac{41T}{39T} \times \frac{25.7A}{78.9A} = 34,243 \text{ Mx.}$$

Figure 7 shows the 0.02 Hz value to be 31,872 Mx.

All the data were taken by simply photographing the sine wave trace of the ac voltage modulation applied to the magnet, the pickup coil voltage and the current signal from the non-inductive shunt, and then using graphic means to determine the magnitude and phase shift between the signals. The ac voltage modulation applied to the magnet was always set at 2 V peak-to-peak throughout the frequency range. Figure 6 shows the importance of taking the current signal from a non-inductive shunt. Different impedance values and phase shift angle are obtained when using the current signal from a conventional shunt. The difference is noticeable at frequencies even lower than 1 kHz. By folding the signal wires from the shunt down on top of the shunt so as to minimize the size of the loop formed by the signal lead, the two signals give far better agreement.

ACKNOWLEDGMENTS

The author wishes to thank E. D. Bush, Jr. for his help in initially setting up the experimental gear for some measurements on other magnets and to J. G. Katcher for reassembling the test set up for the measurements described in this paper.

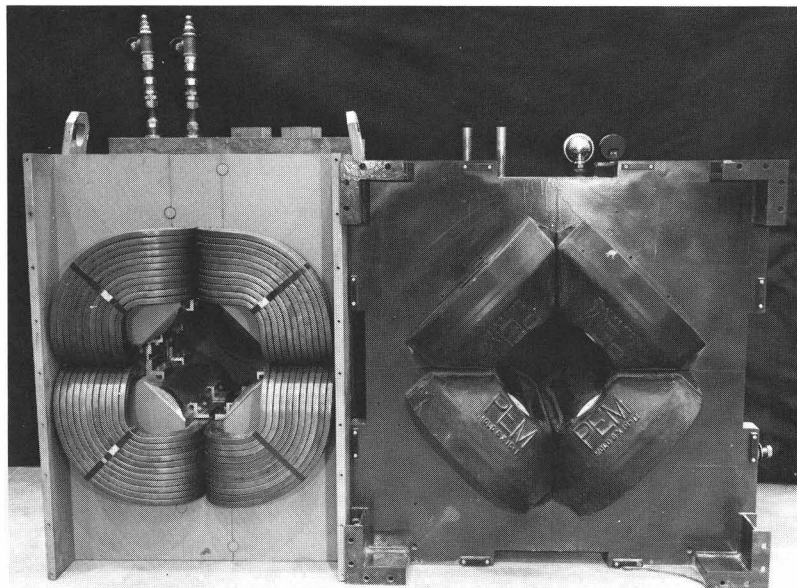

Fig. 1. 8Q16M/7 and 8Q16MK-1 quadrupole magnets

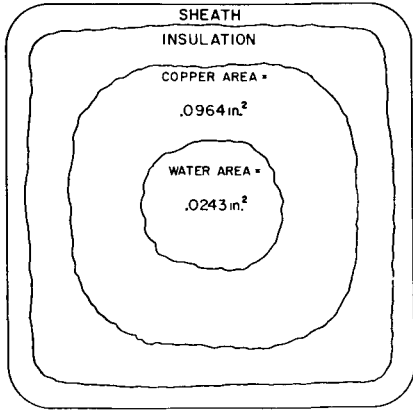

Fig. 2 Mineral insulated conductor

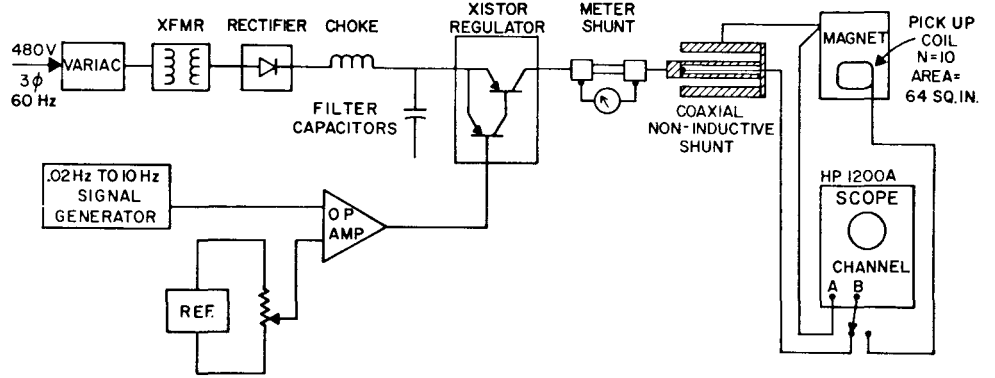

Fig. 3 Test set-up block diagram

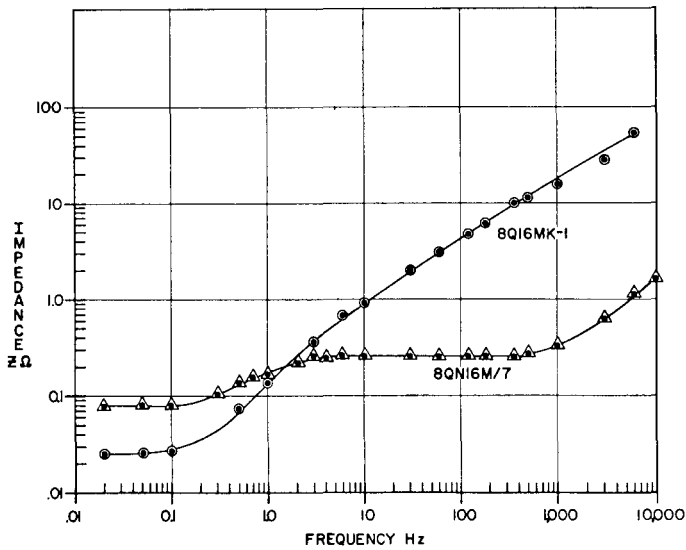

Fig. 4 Impedance vs frequency

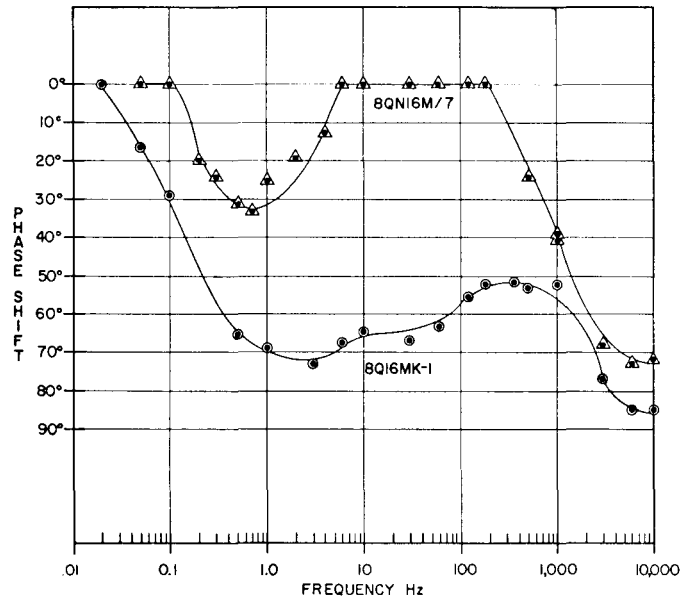

Fig. 5 Phase shift between applied volt and current

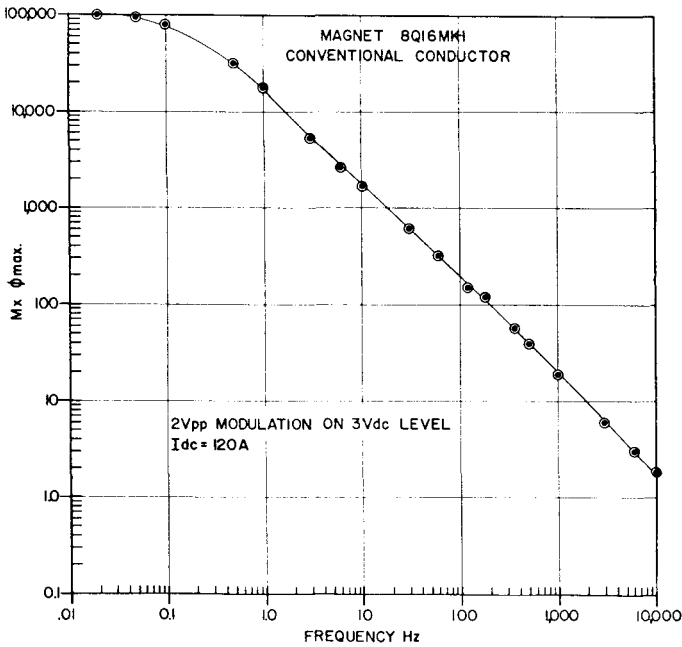

Fig. 6 Ripple flux vs frequency for 2 Vpp voltage modulation on magnet 8Q16MK-1

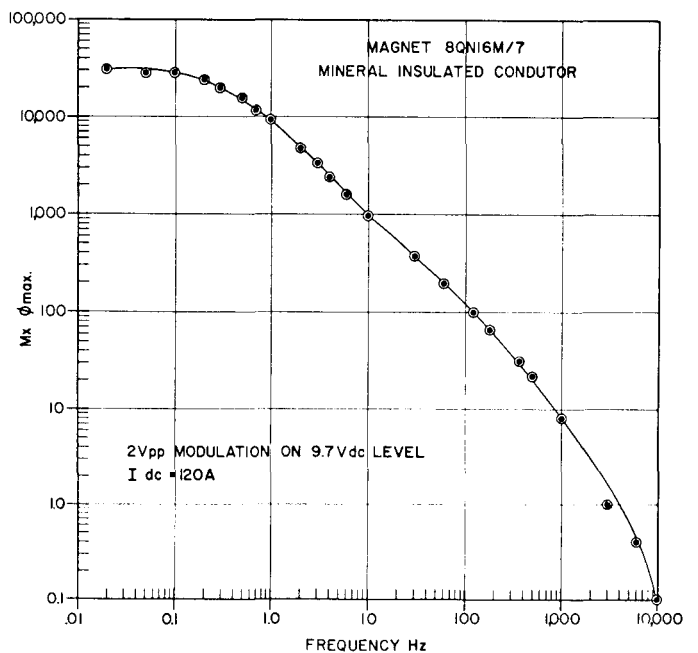
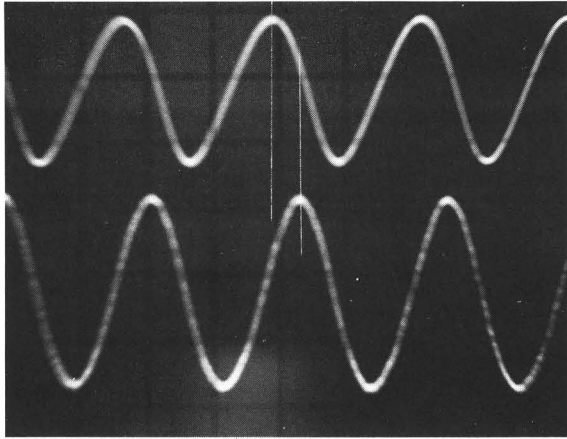

Fig. 7 Ripple flux vs frequency for 2 Vpp voltage modulation on magnet 8Q16M/7



8QN16M/7 10KHz

$$V = 2.18$$

$$Z = 1.7\Omega \theta = 74^\circ \text{ PHASE SHIFT}$$

$$I = 1.28\text{A (NON-INDUCTIVE SHUNT)}$$

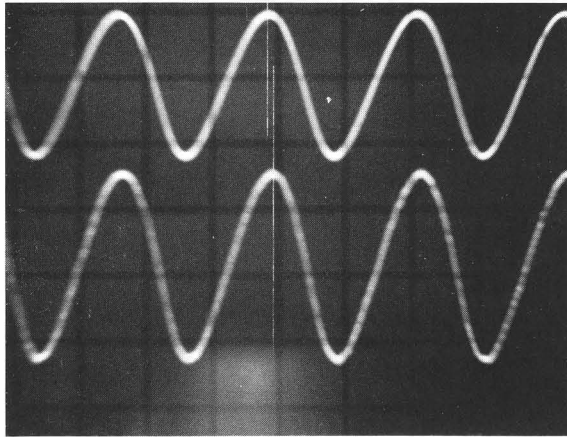

8QN16M/7 10KHz

$$V = 2.09$$

$$Z = .49\Omega \theta = 16^\circ \text{ PHASE SHIFT}$$

$$I = 4.23\text{A (METER SHUNT)}$$

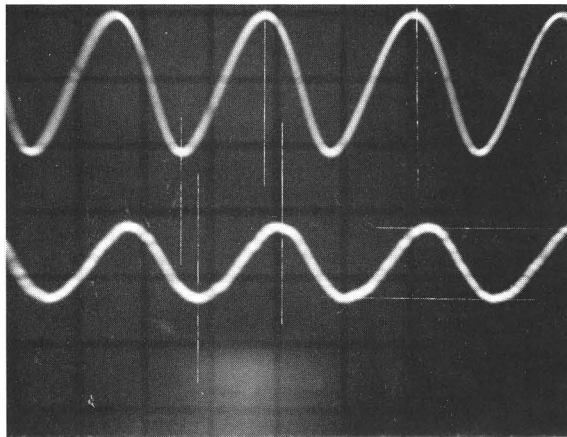

8QN16M/7 10KHz

$$V = 2.0$$

$$Z = 1.28\Omega \theta = 49^\circ \text{ PHASE SHIFT}$$

$$I = 1.57\text{A (METER SHUNT WITH SIGNAL LEAD FOLDED CLOSE TO SHUNT)}$$

Fig. 8 Noninductive shunt vs meter shunt comparison.