

A NEW BEAM-SPILL CONTROL SYSTEM FOR LAMPF*

by

J. R. Parker, J. H. Richardson, and J. D. Easley
Los Alamos Scientific Laboratory, University of California
Los Alamos, New Mexico 87544

ABSTRACT

The high-intensity beam of LAMPF requires careful control of beam loss to minimize activation of the beam channel. This paper describes a beam-spill control system now in operation which limits the average beam loss to an amount allowed by activation criteria, without severely restricting accelerator tune-up and diagnostics work. This average loss is maintained by downward modulation of the beam-pulse width and repetition rate until the loss-producing fault is corrected. Binary and analog signals describing the action are sent to the Central Control Computer where decisions regarding corrective measures can be made by either the operator or the computer. The computer can test all beam-spill monitors simultaneously while the machine is in operation.

I. INTRODUCTION

Operational requirements at high-intensity accelerators demand that beam-spill and beam-spill-produced radiation be limited so that (1) radiation is at a safe level in occupied areas, (2) the residual radiation level in the beam channel is sufficiently low a reasonable time after beam turn-off that personnel access time is adequate for maintenance work, and (3) the accelerating structure will not be harmed. Preliminary studies at LAMPF¹ showed that if access to the beam channel is to be gained two hours after shutdown for a period of two hours, without exceeding AEC exposure limits, the beam-spill activation of the beam channel must be limited to that produced by a uniform loss of 2 nA/m at 800 MeV. The shielding was designed so that for the same uniform beam spill, the dose rate at the nearest point in the main equipment aisle would be <2.5 mrem/h. Therefore, criteria (1) and (2) would impose the same limit on average beam spill. For full beam spill, however, the average dose rate in the main equipment aisle would be 180 rem/h! To prevent this and also because the limitation imposed

by damage to the structure was not well known, the response of the beam-spill monitor system was designed to be peak-dependent so as to act only on relatively high-level beam spills, and to measure the activation of the beam-channel components by the detector output between beam pulses. The system developed could shut down the beam within propagation time plus $\sim 2 \mu\text{s}$.

II. EARLY OPERATING EXPERIENCE

The peak-dependent beam-spill control system so severely limited operation during beam-diagnostics work at both 100 MeV and 200 MeV that its control had to be provisionally locked out. Also, the lifetime of the residual radiation following the beam diagnostics work was found to be greater than expected, clearly demonstrating that activation will set the lowest limit on allowable beam spill.

Therefore, the beam-spill control system was redesigned to control activation, not peak spill. Since activation is a function of average beam-spill-produced radiation, control is now based on the average radiation level. This has the additional advantage that beam diagnostics work (involving spill on collimators or on total absorbers)

* Work performed under the auspices of the U. S. Atomic Energy Commission.

is inhibited only to the extent dictated by activation limits--full beam spill is allowed as long as the average is low enough. A measure of the beam-spill envelope was retained, however, because it had proved useful for guidance during beam-steering and tune-up operations.

III. SYSTEM REQUIREMENTS

Control of the average beam spill could be exercised by control of any combination of peak current, pulse width, and pulse repetition rate. At LAMPF control is exercised through the LAMPF fast-protect system,² a binary system which does not transmit amplitude information. Therefore, control is exercised by modulating both pulse width and pulse rate.

The action of the system developed can be illustrated by the conceptual diagram shown in Fig. 1. The current, i_s , from the detector is proportional to the beam-spill radiation. This current is integrated by capacitor C to obtain its average value. From this a current, i_a , representing the allowed beam-spill radiation, is leaked off through the large value resistor R_a . The allowed beam-spill current can be adjusted by changing the potentiometer R_b . When the voltage across C is high enough, the infinite impedance relay K operates, opening its contacts. These contacts are in series with the fast-protect system. When open, the beam is turned off at the injector. With no beam the current, i_s , drops below i_a and the voltage across C decays until it is low enough that relay K's contacts close. The injector is then allowed to turn on.

Both pulse width and repetition rate are modulated as shown in Fig. 2. For full beam spill at 800 MeV the system will allow one 25 μ s pulse every 60 s. The width of this pulse is determined by:

1. Operate time of the beam-spill monitor
2. Operate time of the fast-protect system
3. Propagation time to the injector
4. Turn-off time of the injector
5. Propagation time back to the point of spill.

Normal accelerator operation is with a pulse width of 500 μ s and a repetition rate of 120 pps. Full beam-spill radiation is thus reduced by a factor of 1/144000, which is tolerable.

Although this mode of operation makes its own decision regarding pulses following a spilled pulse, it is not anticipated that normal operation will ever allow modulation of either pulse width or repetition rate. Therefore, it is planned to have the computer tally the number of spilled pulses exceeding the allowable limit and make decisions regarding continued operation according to prevailing circumstances.

A number of operational constraints did not allow the use of the simple system illustrated. The primary constraint was a requirement to hold the voltage excursion across C to a low value so as to minimize the leakage current. This leakage would vary in an irrational way with time, as the cable from the detector suffers from radiation damage. Therefore, the simple expedient of employing the instantaneous capacitor current as a measure of the beam-spill envelope was not employed because of the cable voltage modulation which would have occurred. An op-amp integrator was employed (see Fig. 3) with the integrating capacitor in the feedback loop, holding the cable voltage to within a few millivolts of zero. The envelope signal is recovered by differentiation following the integration. This process, with appropriate bandwidth control also removes some of the electrical noise from the signal.

As shown in Fig. 3, the system has three output signals in addition to the binary signal to the fast-protect system. A second binary signal goes to the Central Control Computer to identify the source of the fault signal. The beam-spill envelope and the average beam-spill signals go to the Central Control Room for viewing and processing by appropriate software, as required. The computer may also check the performance of the beam-spill control system by turning on a small lamp located within the detector housing.

IV. DETECTOR

The detector is the one designed for the original system.³ Experience with this detector has been excellent; therefore, it has not been changed. Although changing the control base from peak beam spill to average radiation reduces the dynamic range and wide variation of sensitivity required of

the detector, the variable sensitivity will still be required. The primary sensitivity of the detector, a liquid-scintillator multiplier-phototube combination, is to γ radiation, though activation of the beam-channel components is by neutrons. Hence, since the γ/n ratio will vary by at least 2:1 and the n/p ratio by 25:1 over the length of the accelerator, the variable sensitivity is essential. The variable sensitivity also permits adjustment of the "allowable" beam-spill radiation as experience dictates.

V. HARDWARE

Details of the detector are shown in Ref. 3. The electronics for each detector are mounted on printed-circuit boards in 8½ in. NIM module station units as shown in Fig. 4. Each module carries its own adjustable multiplier-tube high voltage supply, an adaptation of a supply developed for the space program.

VI. COMPUTER OUTPUT

The computer output is completely flexible, limited only by software. One plot of beam spill vs module number, taken from a graphic display in the Central Control Room, is shown in Fig. 5. This has proved particularly useful during accelerator tune-up. A number of other displays are also available. The beam-spill envelope from each detector station unit may be viewed on either the graphic

display or on a multichannel oscilloscope. The latter enables comparison of the envelope with other signals such as the rf envelope, rf phase, or rf beam loading.

VI. CONCLUSION

An essential control of beam-spill-produced radiation has been developed which is reliable, low in cost, and has sufficiently variable sensitivity to meet any conceivable change in allowable activation of the beam channel. Since over 50 of these systems will be required, the low cost per unit and low maintenance costs are important considerations. Variable sensitivity at the detector has the advantage that identical electronics can be employed at each detector station, thus reducing the required number of spares. The total replacement cost is expected to be ~\$1000/yr for the entire accelerator.

REFERENCES

1. D. R. F. Cochran and H. I. Israel, Proc. on Ac. Shielding, ANS SD-3 255 (Nov. 1965).
2. A. L. Criscuolo, Proc. Particle Ac. Conf. F-9, Chicago (1971).
3. J. R. Parker, J. H. Richardson, J. D. Oetting, and J. D. Easley, *ibid*, J-37.

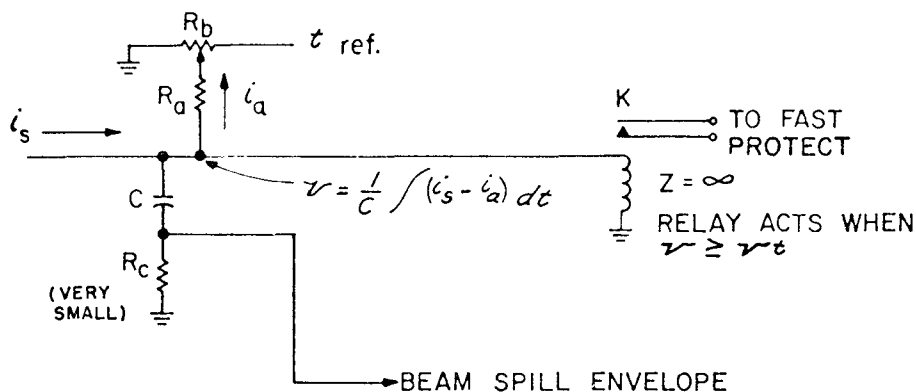

Fig. 1 Conceptual beam spill control system

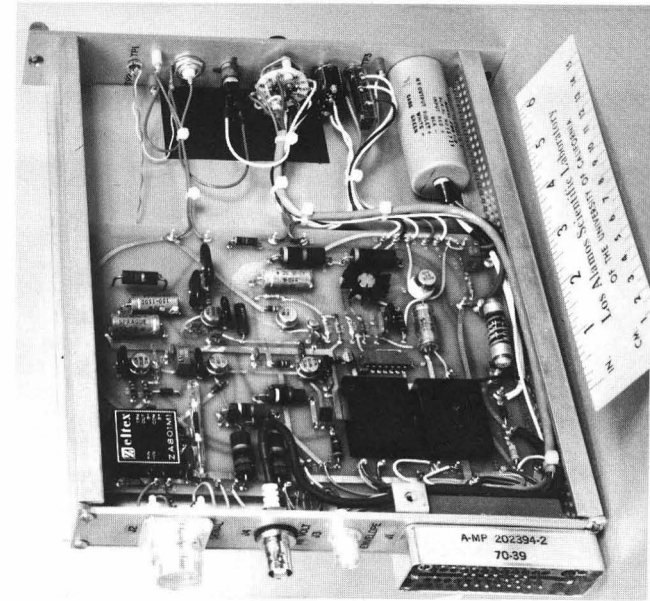

Fig. 4 Control system NIM module

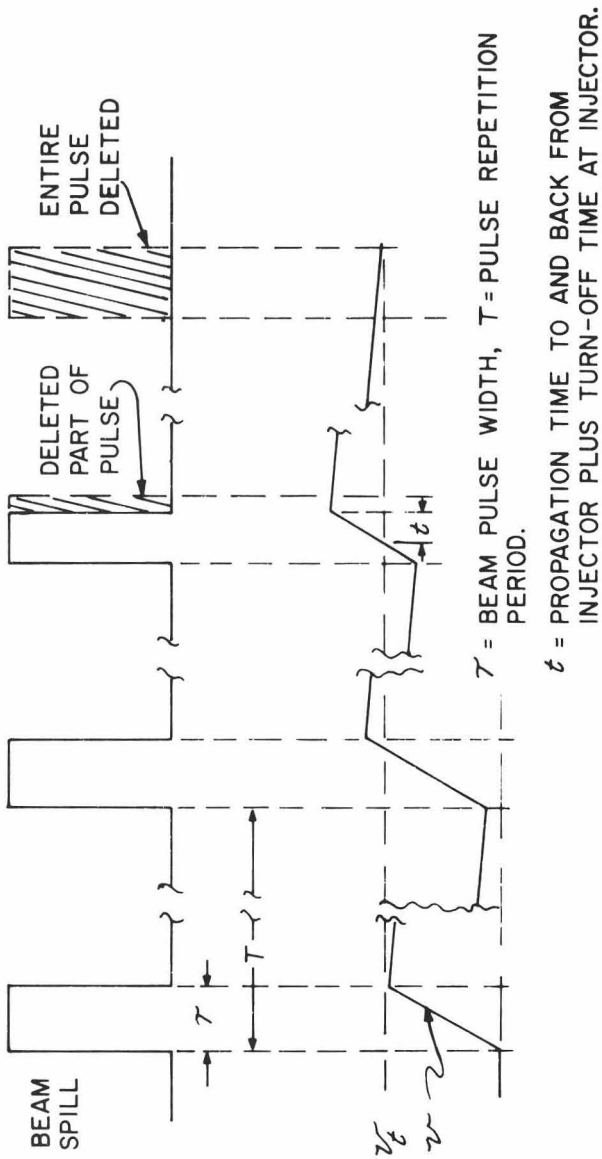

Fig. 2 Beam pulse modulation by beam spill control system

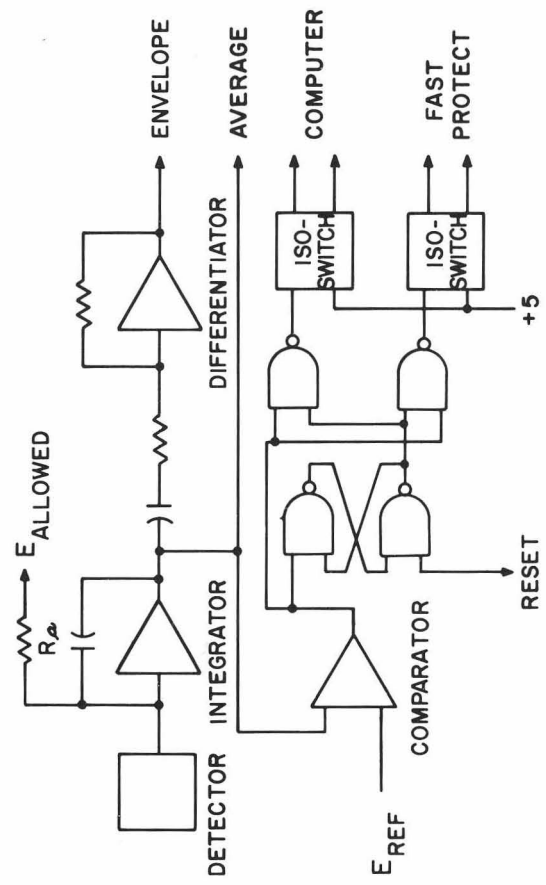

Fig. 3 Simplified system diagram

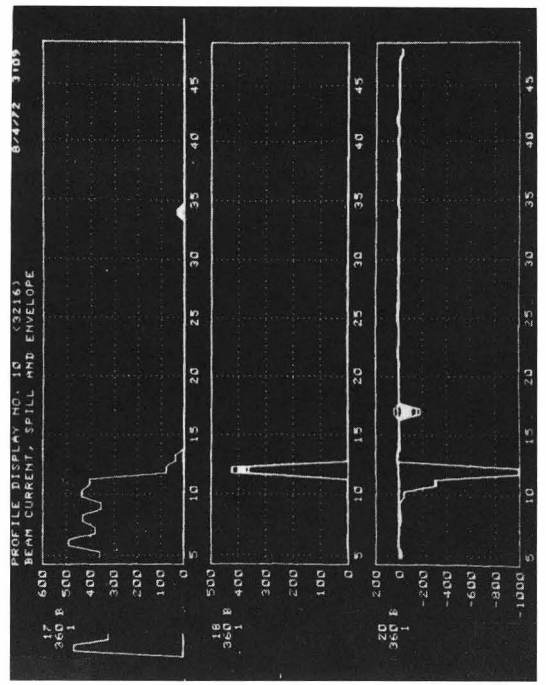

Fig. 5 Computer output display