

THE CHALK RIVER HIGH CURRENT TEST FACILITY

by

B.G. Chidley, S.B. Hodge, J.C. Brown,
J.H. Ormrod, J. Ungrin
Atomic Energy of Canada Limited
Chalk River Nuclear Laboratories
Chalk River, Ontario, Canada

I. Introduction

The possibility of electronuclear breeding of fissile materials using an intense beam of protons to produce spallation neutrons has been recognized for many years. (1,2,3). This is not an economically attractive process using present accelerators but it is possible that development of a high current 100% duty factor linear accelerator could lead to a practical system.

The aim of the High Current Test Facility is to study problems to be encountered in the low energy portion of such an accelerator. It consists of a 750 kV dc supply, accelerating column, beam transport system, and 3 MeV Alvarez linac, as shown in Fig. 1.

This facility will operate with a 100% duty factor and will have problems not met in a comparable pulsed accelerator due to high average power requirements and to high average power in the beam even at low energy.

II. Choice of Operating Parameters

The choice of operating parameters was primarily for studies of space charge effects of the 100% duty factor technology but was influenced by the availability of equipment and designs from the ING study (4).

- (a) Injection energy. The injector was designed to be air insulated for ease of maintenance which places a limit of about 1 MV on the terminal voltage. The present injector operates at 750 kV for improved reliability but has provisions for upgrading to 1 MV.
- (b) Frequency. Space charge problems in a linac can be studied to advantage if a relatively high frequency is used since the current capability decreases at higher frequencies and less output is required from the injector to reach space charge limiting. The required gradients in the drift tube quadrupole magnets increase with frequency and this limits the maximum frequency that can be used. $268\frac{2}{3}$ MHz is a reasonable compromise.

- (c) Output energy. 3 MeV was chosen because it is low enough that activation and neutron production will not be a problem, and yet the accelerator will be long enough to study capture into a stable bunch. For example: a particle injected in the wrong phase will find the focussing quadrupoles unstable by cell no. 15 (out of 25 total) and strike the drift tubes.
- (d) Beam current. The expected space charge limit of the linac is 50 mA but the remaining components are being given capabilities of operating up to 100 mA in case this estimate is low or design modifications increase it.

III. Description

(a) Injector

The injector power supply is a 750 kV, 180 mA dc cascade Cockcroft-Walton generator having a normal stability better than 0.1%. It is powered at 10 kHz from a motor-generator frequency converter unit.

The accelerating column which mounts between the high voltage dome and the Faraday cage wall is shown in the upper right detail of Fig. 1. The outer vessel is designed to contain SF₆ at a pressure of several psi gauge.

The central column is a high gradient ceramic-titanium accelerating column designed for the space charge equivalent of a 120 mA dc proton beam assuming zero emittance.

Fig. 2 shows the assembled vacuum vessel and an exploded view of the accelerating electrodes and interspaced stress relieving torusses. In this view the beam travels up. The extractor electrode (not shown) mounts directly on the ion source assembly. A Pierce potential distribution is produced over the first 200 kV and a uniform 3.1 MV/m gradient is used for the rest of the column. The 2nd last electrode is at -10 kV to stop backstreaming electrons.

Since this column is for a dc (as opposed to pulsed) beam voltage shifts

from spilled beam will not be smoothed by the interelectrode capacity. Rather than increasing the current in the potential dividing chain to reduce voltage shifts, the extractor electrode is powered by a separate supply and has a reduced aperture so that it rather than the other electrodes absorbs most of the spilled beam.

The ion source is a von Ardenne duoplasmatron. In tests on a test stand this source has produced 100 mA dc beams with an emittance invariant of 3.2π mm mrad, and proton component $> 70\%$. Two 1000 ℓ/s (nominal air) ion pumps are used at the ion source end of the column to maintain a pressure of $\sim 10^{-6}$ (air equivalent).

A view of the injector as seen in the Faraday cage is shown in Fig. 3. The beam line area beyond the cage wall is seen in Fig. 4.

"Electron Sweepers" consisting of curved plate electrodes and water cooled copper tubes produce a transverse electric field of up to 20 kV/m inside the beam line throughout the quadrupole section to keep the beam free of electrons.

(b) Linac Tank

The specifications of the Alvarez linac are given in Fig. 5. Note that it has a high rf power loss per unit length and that the beam loading is high. Because the wavelength is shorter it is smaller in diameter than a 200 MHz linac and it contains a larger number of cells for its length.

A sketch of the Alvarez tank is shown in Fig. 6. It has a copper clad steel outer wall, copper rf end plates and steel vacuum end plates. The figure shows the vacuum pumping port but not the rf drive or signal ports. The rf drive loop, the rf seals between the wall and end plates, and between the wall and the drift tube stems follow the techniques used in the experimental short tank to be discussed later.

To keep the structure as simple as possible there are no tuners in the tank; the drive frequency will be adjusted to follow variations in tank frequency caused for example by temperature transients during start-up. Fig. 7 is a photograph of the tank in its present state. None of the drift tubes, cooling manifolds, vacuum pumps etc. are in place.

Fig. 8 shows a drift tube with a magnet in place awaiting final placement and brazing of the end cap. Although each

drift tube has a different length the magnets are all the same size and operate at the same field.

The magnet design parameters are
11.43 cm o.d.
bore 1.84 cm
gradient 6.5 kG/cm
length (including coil) 3.0 cm
effective gradient x length product 19 kG.

The coil is formed from hollow conductor wound 4 turns per pole and insulated with polyimide tape. This material can resist the melting temperature of a gold-germanium alloy which is used for the final assembly braze to join the lid to the drift tube. The winding is done somewhat differently than the LAMPF drift tube magnets to avoid some of the sharp bends and produce a more compact winding.

Fig. 9 shows the measured gradient on the axis at 700 amps as a function of position. The integrated gradient x length product is 22 kG.

The drift tube adjustment fixture is shown in Fig. 10. It is based on the fixture described by O'Meara & Palmer for the NAL 200 MeV linac (5). The drift tube clamps can hold the drift tubes in any fixed position but do not permit complete adjustment without the aid of the fixture which can be positioned over any of the drift tubes.

(c) Rf Power System

The rf power is supplied by an RCA A15039 triode amplifier with a nominal rating of 1.2 MW cw. This tube has a double ended coaxial structure and is similar to the 7835 which is widely used in accelerator applications except that it has a double wound grid, giving a higher amplification factor, and a knurled plate surface with increased cooling to allow 750 kW plate dissipation.

A simplified cross section of the amplifier structure is given in Fig. 11. This is a grounded grid amplifier with double ended resonators operating in the $(3/2)\lambda$ mode (6). The input and output resonators are arranged coaxially with tuning plungers at both ends and coupling connections at one end (top for the input, bottom for the output).

The diagram shows two of the four plate cooling water lines. They connect to the plate in an essentially rf field free region and have double bucket rf chokes to provide dc and rf isolation.

There are two output taps to 100 ohm lines which join to a single 9 3/16" diameter 50 ohm output line. All rf contacts are made with conduction cooled finger stock rated at 40 A/inch.

Typical operating characteristics are shown in Fig. 12. It was only operating at 200 kW but shows the gain and efficiency to be expected and that grid and plate currents are roughly equal.

The drive amplifier was built under contract by the University of Manitoba. It uses an RCA A2548 which is a single ended tetrode with a nominal capability of 100 kW cw. The cavities are $(3/4)\lambda$ coaxial structures, air cooled except for the water cooled plate tuning plunger. It requires 1 kW drive.

(d) 100% Duty Factor Short Alvarez Tank

Several design features of the linac could be tested in a short Alvarez tank designed by Hodge and Hepburn (7) to confirm design concepts and fabrication techniques to be used in the ING accelerator. This tank used approximately the same average axial field as the high current test facility so it shared many of the problems associated with 100% duty factor operation.

Fig. 13 shows a view of the tank.

The tank modelled a 3 cell portion of an ING accelerator tank from the region near 50 MeV. It was split longitudinally with the drift tubes supported on a completely separate strong back which ran below the accelerator tank.

The end view of the tank is shown in Fig. 14 and the cell geometry is shown in Fig. 15.

The rf currents on the wall are high for rf gaskets or finger stock so alternative rf joints have been used.

The seal between the end plate and the tank wall was made by a copper-to-copper knife edge contact as shown in Fig. 16. The vertical screws center the plate, the horizontal screws force the tank wall to bite into the end plate. The vacuum seal is a separate edge weld seal.

This type of joint was not possible for the drift tube stem to tank wall rf seal so a copper skirt was used which was flexible enough to permit adjustment of the drift tube. This is shown in Fig. 17. It was welded to both the drift tube and the tank wall.

Fig. 18 shows the cross section of the drive loop. Note that it does not extend into the tank and is not covered by a vacuum window. The vacuum window is back in the transmission line where it is away from the tank rf fields and is subjected to no more heating than the other coaxial line spacers. It is made of teflon and forms a vacuum seal by compression.

The rf system used is shown in Fig. 19. The AFC operates by frequency modulating the rf oscillator and passing the reflected power through a phase-sensitive detector to produce an error signal. This signal controlled the tank resonant frequency by altering the coolant temperature. The amplitude and frequency of the modulating signal depends on the Q of the tank but many tanks of similar Q could be controlled together.

IV. Test Results

(a) Injector

Without SF₆ in the insulating vessel the accelerating column was capable of holding 350 kV. With ~ 1 psig SF₆ the column was conditioned to 800 kV in 3 days.

Subsequently it was possible to expose the column to air for periods of ~ 1 day and after pumpdown to 10⁻⁷ torr to raise the applied voltage from 0 to 800 kV in less than 15 minutes without noticeable microdischarge rates.

Communications with the HV dome were done with 22 fibre-optic transmission lines using a PDP-8I computer based control system. These units have performed satisfactorily through many machine arcdowns. Problems were encountered with measurements at the dome voltage due to the non-linear frequency response of the voltage divider chain when voltage spikes up to 20 kV transmitted to the digital voltmeter produced a number of instrument failures. This was solved with a voltage clipping protection circuit.

Very limited operating experience has so far been gained on the injector. Extracted beams have been limited to 5 mA dc. X-radiation fields from the column have been relatively moderate and do not at the present time appear to pose a major problem. The energy spectra of the radiation fields indicate that an appreciable portion of the backstreaming electrons producing the radiation are produced near the ground potential end of the column.

(b) Rf Supply

We have had considerable operating experience with the drive amplifier, which has delivered up to 55 kW to the 100% duty factor short Alvarez tank. Although there were some early mechanical problems with the plate cavity arrangements, the amplifier has proven quite reliable.

The triode has been subjected to extensive tests leading to a number of proposed modifications (including simpler operating procedure, full range power control, remote tuning) but the experimental stand has not permitted sustained operation at high power.

(c) Short Alvarez Tank

The initial rf conditioning of the tank proceeded slowly because it coincided with commissioning the tetrode rf amplifier and developing a coupling loop.

Multipactoring in the tank was calculated to occur at very low drive level (200 watts) but except for a temporary increase in tank pressure at low power this could not be observed. A 3" diameter viewing port allowed observation of the tank interior and the coupling loop, directly up to 10 kW, and with a mirror and telescope at higher power. No visible discharge occurred at low power but above 7 kW pin-points of light could be seen on the surfaces, particularly near the ends of the drift tubes. They were stationary and although they did not correspond to visible marks on the surface they may have been due to dust particles. They were no longer visible at this power after sustained operation of the tank at 50 kW.

After about 4 hours total operation at 30 kW we observed that most of the blades of the rf skirt connecting the drift tubes to the tank wall had been burned off, the remaining blades being at the sides of the drift tube. This was unexpected since wall currents should not have produced more than 3 W/cm². The rf behaviour of the tank appeared to be unchanged so the remaining blades were clipped off. Later, tests on a low power 24 drift tube tank have shown no differences in central axis field patterns when stem rf gaskets were replaced with insulating collars.

Above 35 kW multipactoring occurred in the evacuated portion of the drive line between the loop and the teflon window. Once initiated the discharge travelled toward the generator and stopped at the window which quickly became sputtered with copper and inoperable.

The most effective way to eliminate the multipactoring was to apply an axial magnetic field of about 50 gauss by strapping 8 bar magnets around the outside of the drive line. With the magnets in place there was no further evidence of multipactoring.

The system of frequency control via cooling water temperature worked at low power but at higher power was unable to cope with the large transients due to disparity of the time constants involved. This made it unsuitable for the intermittent operation during commissioning although it probably could have been made to work for operation at constant power. For intermittent operation it was simpler to use the error signal to change the tank temperature while cooled with constant temperature water.

The following points are relevant to the 3 MeV tank.

(a) The metal-to-metal seal of the end plates to side walls provided an adequate rf seal with no evidence of arcing or burning having taken place so this design will be used.

(b) The rf skirts on the drift tube stems appear to be unnecessary so it is planned to build the 3 MeV tank with no rf seal on the stems.

(c) Placing the rf window in the drive line to avoid high tank fields appears to work well except for multipactoring in the evacuated portion of the drive line. This can be controlled and is probably easier to cope with than problems associated with ceramic domes.

(d) The problems of feeding rf power to a resonant load do not appear to be serious, although a tank with varying beam loading will introduce new complications.

V. Present Status

The High Current Test Facility is scheduled for completion next year.

The 750 kV injector has operated at full voltage but low current (5 mA compared to 100 mA capability).

Experiments have been done to check construction techniques for the 3 MeV linac tank. The tank shell is completed and the drift tubes are under construction. The rf supply is about to be dismantled for modification and moving to the accelerator building.

References

- (1) W.B. Lewis, "The Significance of the Yield of Neutrons from Heavy Nuclei Excited to High Energies", Atomic Energy of Canada Ltd. AECL-968 (1952)
- (2) W.B. Lewis "Accelerators for Intense Neutron Sources", Atomic Energy of Canada Ltd. unpublished report DL-90 (1968)
- (3) W.B. Lewis, "Energy in the Future - the Role of Nuclear Fission and Fusion", Atomic Energy of Canada Ltd. unpublished report DM-120 (1970)
- (4) T.G. Church, "The AECL Study for an Intense Neutron Generator", Atomic Energy of Canada Ltd. AECL-2750
- (5) J. O'Meara, M. Palmer, "Mechanical Design Features of the NAL 200 MeV Linac Injector", Proceedings of 1968 Proton Linear Accelerator Conference, p. 30 (1968)
- (6) R.L. Poirier and P.J. Waterton "Cold Tests on the A15039 Triode", Atomic Energy of Canada Ltd. Internal Report FSD/ING-115 (1968)
- (7) J.D. Hepburn, S.B. Hodge, "The Short Length Alvarez Tank Experimental Facility", Atomic Energy of Canada Ltd. Internal Report FSD/ING-162 (1969)

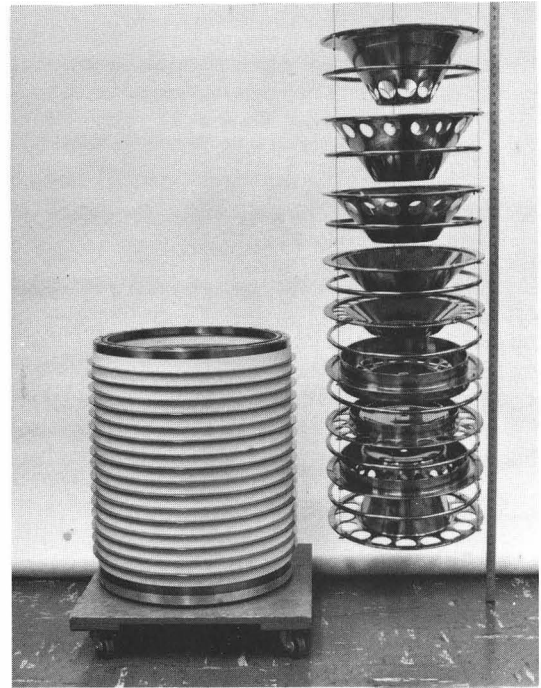

Fig. 2. Accelerator column and exploded view of electrode structure.

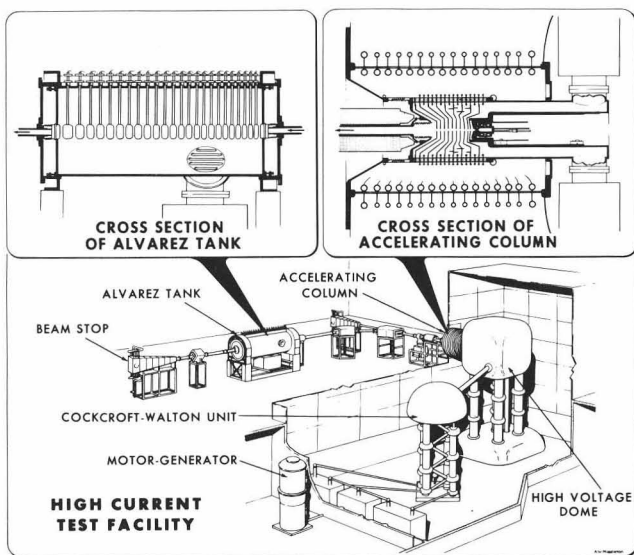

Fig. 1. General view of high current test facility.

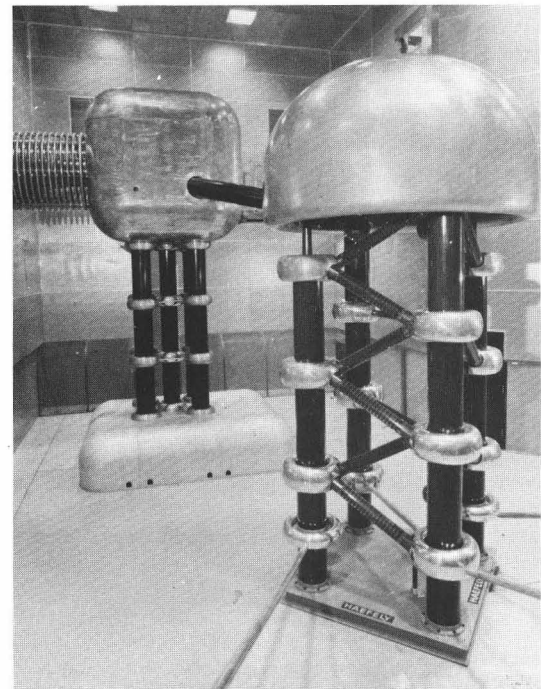

Fig. 3. 750 kV supply and accelerating column.

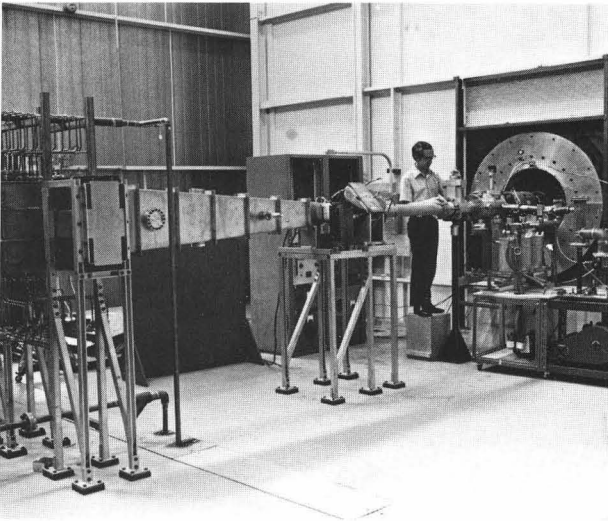

Fig. 4. Beam line for injector tests.

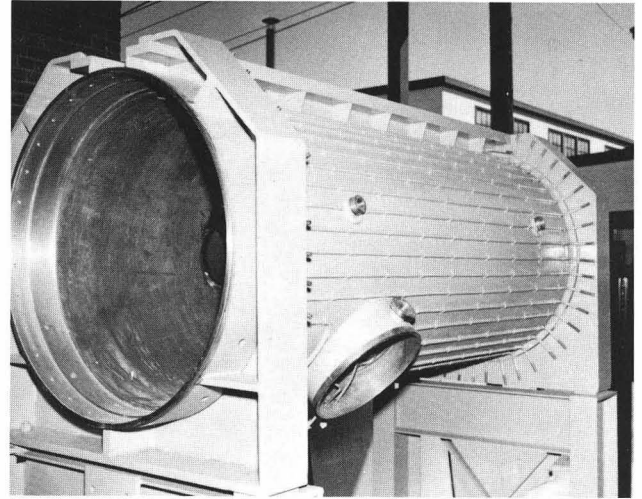

Fig. 7. Alvarez tank.

Input Energy	750 keV
Output Energy	2.982 MeV
Frequency	$268\frac{1}{3}$ MHz
Tank Diameter (inside)	71.11 cm
Tank Length (inside)	164.97 cm
Drift tube diameter	13.62 cm
Drift tube stem diameter	2.54 cm
Number of cells	25
Rf power (no beam)	97 kW
(50 mA)	209 kW

Fig. 5. Basic linac specifications.

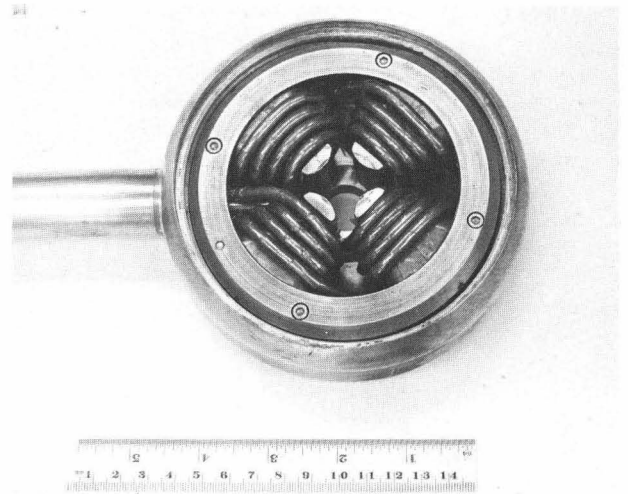

Fig. 8. Drift tube with magnet.

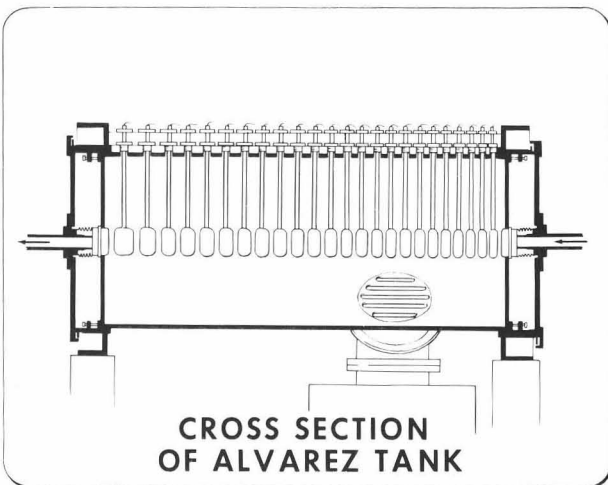

Fig. 6. Cross section of Alvarez tank.

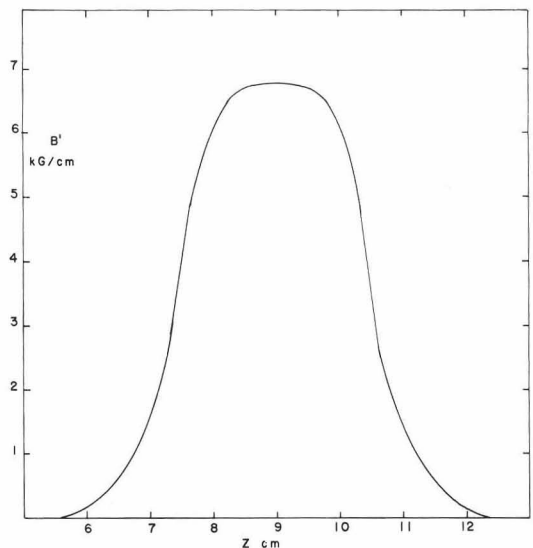

Fig. 9. Axial field gradient for drift tube quadrupole magnet.

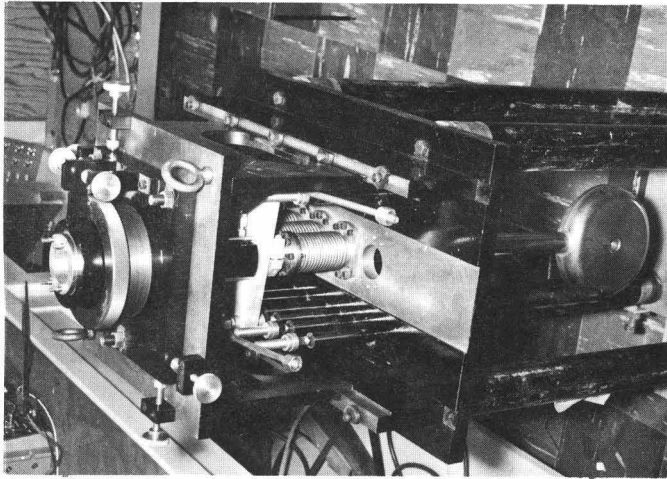

Fig. 10. Drift tube alignment fixture.

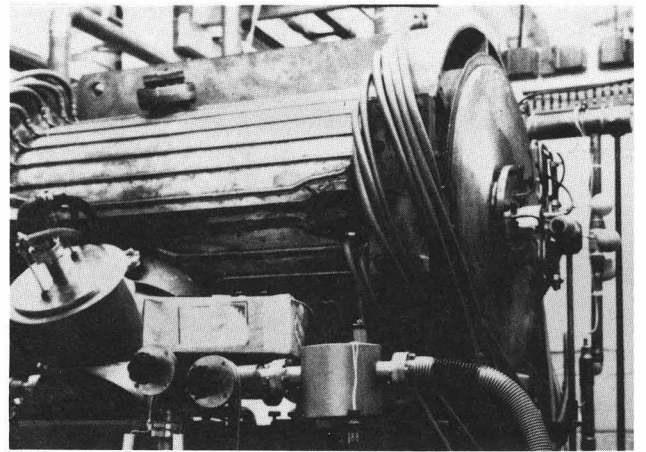

Fig. 13. 100% duty factor short tank.

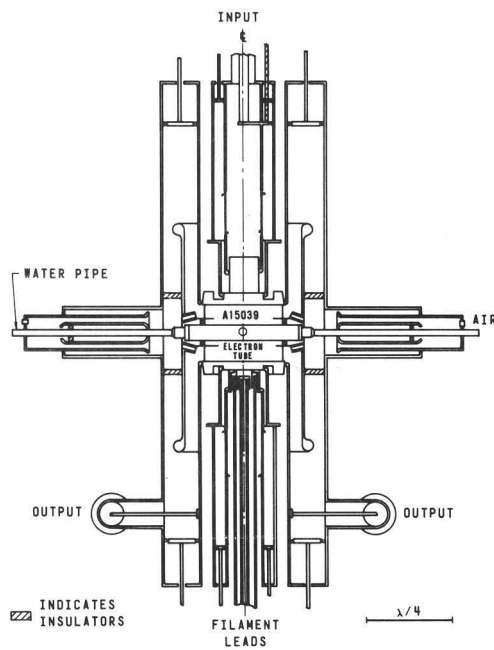

Fig. 11. A15039 amplifier structure.

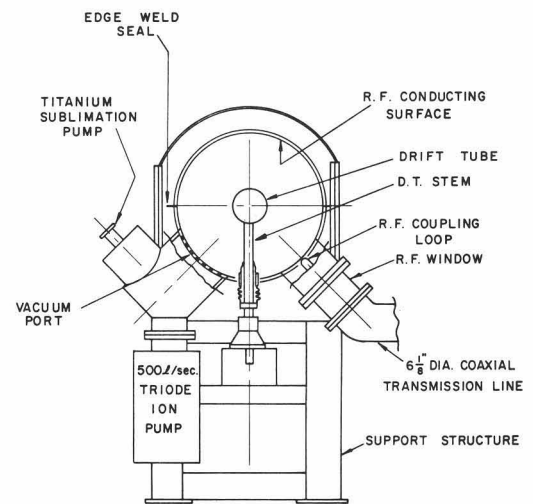

Fig. 14. Cross section of short Alvarez tank.

TRIODE OPERATING PARAMETERS

Fil. volts	4 V
current	7000 A
Cathode current	61 A
Plate current	25 A
Plate volts	15 kV
Bias volts	24 v
Drive Power	15 kW
Output Power	210 kW
Gain	11.5 db
Efficiency	53%

Fig. 12. Typical triode operating parameters.

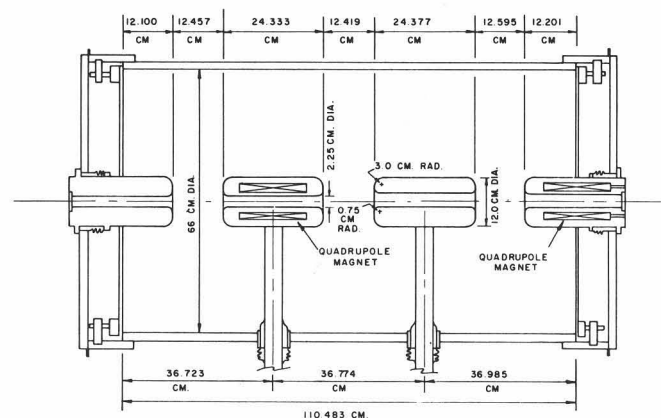

Fig. 15. Cell geometry of short Alvarez tank.

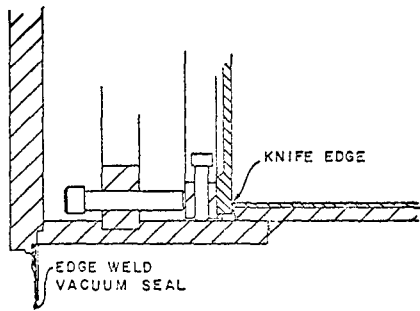

Fig. 16. Rf edge seal between end plate and tank wall.

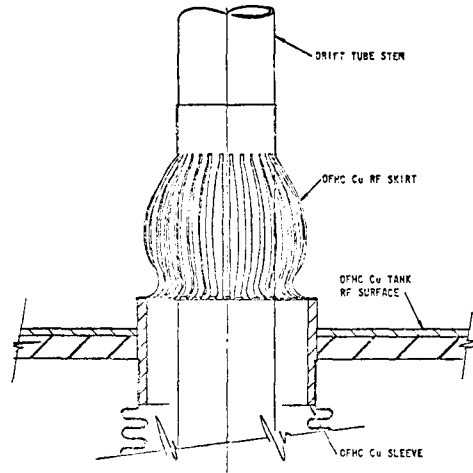

Fig. 17. Rf skirt seal between drift tube stem and tank wall.

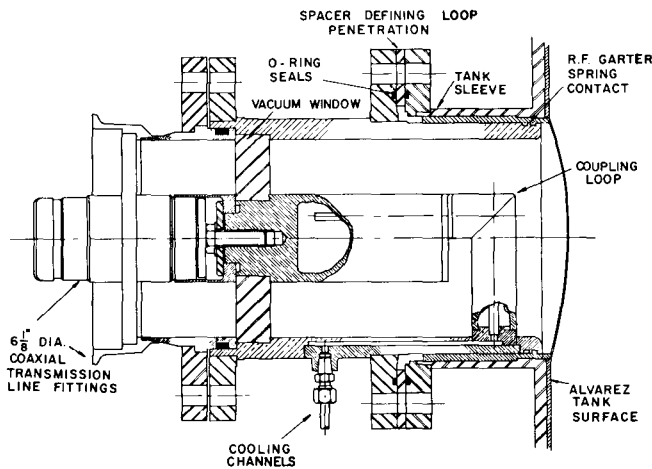

Fig. 18. Rf window and coupling loop.

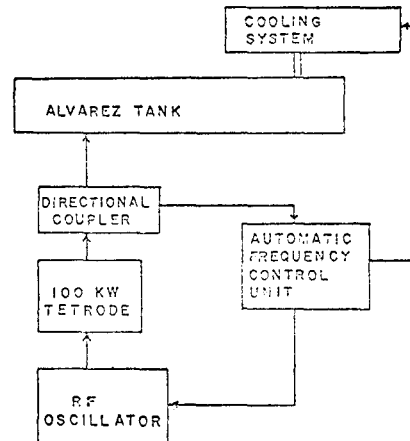

Fig. 19. Frequency control system.

DISCUSSION

Lefebvre, Saclay: What was the brazing material used to braze the ceramic insulators to the metal?

Ungrin, AECL: Polyvinyl acetate.

Lefebvre: What is the field along these insulators?

Ungrin: There is 50 kV between or across each ceramic.

Blewett, BNL: Is there room to add on more structure to this machine to raise the energy by a few more hundred MeV?

Chidley, AECL: No.

Blewett: You have a trap for the back-streaming electrons, but later in the paper you said back-streaming electrons were a problem. Why is this?

Ungrin: The back-streaming electrons have energies up to 700 keV and are too energetic to be stopped by our trap.

Lee, NAL: What type of resistors do you use on the accelerating column?

Ungrin: They are 400 MΩ Victoreen thin film resistors. We use four strings, so the current is 500 μA per string. In several hundred hours of operation only two have opened.

Allen, SLAC: Were the triode characteristics measured into a water load or the accelerator? Was the driver included in the efficiency calculation?

Chidley, AECL: They were measured into the resistive load and the driver was not included in the efficiency calculation.

Allen: Do you think you will achieve 53% efficiency into the accelerator?

Chidley: The amount of reflected power will vary with the beam loading. We will first match the accelerator for low beam loading and after some time we will set the match for heavy beam loading. Thus, we hope to be able to get good efficiency when the beam is at its full value; the efficiency will be low for low beam currents.

Böhne, GSI: How warm does the water used to cool the tank walls become? Do you have a reason to avoid the slug tuner for frequency control?

Chidley: The tank cooling should be as good as that on the prototype tank, which was adequate. Since we have only one tank, we tune the rf system to it, so a tuner in the tank is not necessary.

Böhne: What is the power dissipation per square cm in the tank wall? What is the axial gradient, E_0 ?

Chidley: The total power dissipated in the tank walls is 50 kW. The average gradient is 1.5 MeV/m.