

A SUMMARY OF MEASUREMENTS ON
SUPERCONDUCTING HELICALLY LOADED RESONATORS

J. E. Vetter, B. Piosczyk, J. L. Fricke
Institut für Experimentelle Kernphysik
Kernforschungszentrum und Universität Karlsruhe
Germany

Abstract

Two years of experiments with superconducting helically loaded resonators allow to give a survey on the specific properties of this type of resonator with respect to its use in a low β particle accelerator. The dominant effects are compiled and results important for accelerator applications are given.

Introduction

About two years ago, when we started the project of a superconducting helix accelerator, little was known about the behaviour of resonators and structures at UHF and VHF. Most of the experience at that time was won from experiments with microwave cavities. The surface resistance e.g. as a measure for losses had been found to consist of a temperature dependent part R_{SC} which satisfyingly agreed with calculations based on the BCS theory (1, 2), and a residual resistance R_{res} the nature of which could not be understood completely hitherto though several explanations have been proposed (4, 5). Experimentally it had been shown with a lead plated resonator (5) that the residual resistance showed the same frequency dependence as R_{SC} , namely $\omega^{1.8}$ in the frequency range from 3 GHz to 380 MHz. This promised a very effective application of a low frequency structure with extrapolated values for the surface resistance as low as 10^{-9} Ohm at 100 MHz. Compared to room temperature copper this promised a decrease of losses by about 6 orders of magnitude.

The investigation program on helically loaded resonators consequently first focused on the question if, a by far more complicated structure, the helix, at a frequency below 100 MHz, would show a surface resistance as low as extrapolated from Szecsi's (5) measurements. Further aims of the studies were limitations of the obtainable field strengths, optimum preparation of the surfaces and sensitivity against contaminations before and during operation. Finally the transformation of experience with small single helix resonators to larger scale accelerator tanks had to be practiced. This program has essentially been completed with the construction of the first accelerator section (6). Improvements on surface quality and on the construction of the sections are still highly desirable. Since similar measurements have been undertaken or are under way in the US at HEPL, Stanford; Caltec, Pasadena; NAL, Argonne and ORNL, Oak Ridge, we expect to gain more detailed

results in the near future.

Experimental Arrangements

Our first measurements were carried out to determine the frequency- and temperature dependence of the surface resistance at VHF. A first Niobium helix was vertically mounted into a lead plated copper cylinder and completely immersed into a helium bath (fig. 1). Q values could be measured at frequencies ranging from 30 to 300 MHz, but this arrangement, labeled A, proved unfavorable for obtaining very high field strengths because the insulating properties of the helium were poor (7).

Consequently we used a setup B where the resonator could be evacuated and the helix was cooled internally by superfluid helium (fig. 1). The lead plated cover plate was later replaced by a solid niobium plate and the helix suspensions were electron beam welded to this plate rather than flanged as in arrangement B. This resonator will be labeled C.

We finally reduced the diameter of the outer cylinder and constructed a small all-niobium resonator D, also shown in fig. 1. The favorable results with this technique were obtained too late to be adopted in the construction of the first accelerator section E. This section was fabricated using both niobium and lead as superconductors. Details of this first accelerator tank are given in the paper of Fricke et al., this conference.

Experimental Procedure

All helices were manufactured from 6 mm niobium tube with approximately 0.7 mm wall thickness. As the surface quality was usually poor, we ground and polished the tubes mechanically. In arrangements B to E electropolishing was applied and, except in A measurements, most helices were anodized. The details of the preparation process are omitted here; these data may be found in previous papers (7, 8, 9, 10). After surface preparation, the resonators were assembled with minimum exposure time to air and, except set up A, evacuated to a vacuum of typically 10^{-6} Torr before cooling.

The rf circuit (fig. 2) consisted of a phase sensitive feedback loop acting on the frequency of a VCO generator followed by a power amplifier (11). Resonator power P_C was conveniently measured by means of a directional coupler. The Q values were determined by the decay time of the stored

energy. For convenience all resonators were of transmission type with variable coupling lines.

Characteristic field strengths as the accelerating field $E_{TW,axis}$ and peak fields E_p and H_p had previously been determined as functions of P_{CQ} by perturbation measurements and are added in fig. 1. Assuming no change of these relations at low temperatures, the field strengths could be determined from the measured quantities Q and P_C .

Electron loading could either be seen by the nonlinear response of the transmitted signal or by measurement of the charge on the coupling probes measured by a sensitive dc voltmeter. Field emission was detected and the spectra of the emitted x-rays were measured by a multichannel scintillation counter outside of the dewars.

It should be noted here that the deformation of the helix by action of the electromagnetic forces causes a considerable frequency shift Δf_{stat} and that under certain circumstances ponderomotive oscillations will occur (12). These instabilities have been neutralized by adjustment of the reference phase. As Δf_{stat} is proportional to P_{CQ} , this quantity could be calibrated and consequently used as a convenient measure of the field strengths.

Experiences in Operation of the Resonators

As this paper tries to give only a comprehensive survey on principal effects, the authors restrict themselves to a qualitative discussion of these effects and to a compilation of measured quantities relevant for practical applications. Though most of the effects observed in operation of helically loaded resonators are known from experiments with cavities or microwave structures it will be shown that some properties of our resonators are not in accordance with expectations from microwave cavity measurements.

Low Field Q Values

Though low field Q's are of less importance for accelerator applications, they offer a means to check the quality of a superconducting surface. Extrapolating Szecsi's measurements (5), we expected a residual surface resistance of at most 10^{-9} Ohm at 90 MHz. This value could only be approached in some of our experiments. The best Q of 2.5×10^9 (residual resistance 1.7×10^{-9} Ohm) was measured in arrangement D with an anodized helix. Bare metal helices showed a maximum Q of 7×10^8 (A, D). Measured low field Q's are compiled in fig. 3. To the knowledge of the authors no considerably better surface resistance could be measured elsewhere to date at this frequency. The temperature dependence of our surface resistances was much smaller, namely a factor of 2 to 4 from 4.2 K to the residual

value than can usually be obtained in microwave cavities where factors of several hundreds are no exception. The dependence on temperature we found cannot simply be described by the quantities R_{SC} and R_{res} as mentioned above for microwave frequencies.

Low field Q's were found reproducible within one order of magnitude when the resonators were newly prepared. Application of higher fields deteriorated the low field Q by up to a factor of 4, possibly by processing which is needed to eliminate electron loading. This deterioration can however be completely reversed by temperature cycling. Moreover we made the experience that the virgin Q's increased after the first temperature cycles.

Electron Loading

In all resonator geometries we found electron loading effects (multipacting), more or less pronounced, depending on geometry and preparation. In particular resonators B and C and also the accelerator section E showed strong electron loading (13). Processing, i.e. applying as much rf power as can be tolerated without a thermal breakdown eliminated electron loading. Typical processing times range from half an hour (D) to about 15 hours (E). After contaminations due to a vacuum failure as well as after a temperature rise to 300 K, the electron loading revived. Electron loading is indeed disagreeable but does not offer a fundamental restriction to a use of helically loaded resonators in accelerators, as the high field properties seemed not to be influenced as could be demonstrated in subsequent measurements of the same resonator.

Dependence of Q-Values on Field Strength

All our resonators had a more or less pronounced reversible deterioration of the Q values of up to a factor of 20 with field strength. The dependencies showed no uniform picture but, particularly in D and E experiments, the Q value decreased rapidly at low power levels and saturated towards the breakdown field strength. The nature of this effect is not understood to date. Joint effects could hardly be made responsible for this behaviour as the joint configuration was drastically changed from resonator B to C and also in resonator D where the indium joint at the end plate was replaced by an electron beam weld. All these changes had no major influence on the field dependence of the Q value. Thermal effects must also be considered as very unlikely as in this way the small variation at high power cannot be explained. A field dependent Q could also be observed in a heat treated cavity similar in geometry to our D, measured at HEPL (14), whereas ANL (15) reported a measurement with a constant Q value at least above an electric peak

field of 1 MV/m.

High Field Q-Values

High field Q shall be defined as the Q value at an electric peak field of 10 MV/m where certainly field emission losses are still negligible. High field Q's in our resonators ranged from 10^7 to 3.5×10^8 with 10^8 as the most probable value (fig. 4). On the first view these values seem to be very low as compared to microwave cavities but one must keep in mind the different geometry constants of the helix ($\sim 5 \text{ Ohm}$) and of cavities (TM_{010} : $\sim 300 \text{ } \Omega$), the surface resistances of both are of the same order of magnitude. The high field Q's were not, or very little, affected by thermal cycling, processing or preceding operation under field emission load, it suffered only by heavy contaminations before cooling or at low temperatures, as e.g. a vacuum breakdown. However, the high field Q's, though completely deteriorated by a vacuum breakdown, recovered by temperature cycling as was proved in D and E experiments.

It is a special property of the helix that the maximum losses are limited sharply when the heat flux in the helix tube exceeds a certain value, namely 1.5 W/cm^2 (16). In fact the high field Q's of our resonators were so low, that in most of our experiments the maximum field strengths were limited by thermal breakdown due to excessive surface losses. As the mechanism of Q variation with power is not understood to date and as most careful preparation does not improve on the high field Q, shunt-impedance is limited at least in the very low β part of our accelerating structure where the small pitch of the helices exclude wider cross sections of the tubes.

Low Q values at high field strengths do not necessarily cause an early breakdown. In some geometries, e. g. E, the major losses do not seem to occur at the helix from which the heat dissipation is limited, but in other parts of the resonator. In this case we could feed up to 3 times more power into the resonator as would correspond to the critical heat flux in the helix tubes.

Field Emission Loading

At electric peak fields of more than 10 MV/m field emission (FE) can occur. The onset of FE and the highest multipacting barrier were clearly separable. The emitted x-rays proved to be a very sensitive measure of the FE effect as they could be detected at field strengths far before the FE load could be observed in the electric response of the resonators. Whether FE loading causes a thermal breakdown or not depends on what fraction of the emitted electrons hit the helix surface. We found that in B, C, D experiments the load of electrons accelerated by radial fields and, in this way hitting the outer cylinder, dominated. Breakdown was found in this case at

higher fields than it was expected from the respective Q values. Fowler Nordheim plots of x-ray intensity and additional losses yielded corresponding enhancement factors which, under the assumption that the electrons originate from bare metal whiskers, agree with conventional field emission investigations. FE intensity as well as enhancement factors vary in different experiments without a particular tendency. Even abrupt increases or decreases of dose rate could be observed at a constant field level in anodized resonators. Sputtering with helium as reported to be useful to decrease the FE intensity (17) proved not or little efficient in our experiments.

For the present we can state that helically loaded resonators can certainly be operated up to a peak field of 15 MV/m without an influence of FE on the breakdown behaviour. With FE load peak fields up to 25 MV/m could be obtained in stable operation (D). These values are important for parameter calculations of accelerator sections.

Breakdown Behaviour

Discussing the high field Q values, it was mentioned that our resonators were limited by thermal breakdown. In fact this was the only breakdown mechanism we could observe. Unlike, in cavity type resonators where "magnetic" breakdown is the most likely effect, we could obtain H_p fields as large as 1250 Gauß in short term operation (D) (fractions of a second) and 1000 Gauß for unlimited time. This exceeds by far the maximum field strengths of microwave structures and is only comparable to a few x-band cavity measurements. This information is valuable in as far as magnetic peak fields need no more be taken into account for the parameter optimization of the accelerator sections. For this reason only the maximum electric peak fields are compiled in fig. 5 rather than magnetic fields.

No measurable changes of the breakdown field resulted when the temperature of the helium bath was varied from 1.4 to 1.9 K. (B, C, D). This observation is in accordance with measurements of the critical heat flux of superfluid helium in tubes (16). It also offers the advantage that the operating temperature can be changed in wide limits and thus need not be stabilized.

Resonator D, whose axis is vertically positioned in the dewar, showed a particular breakdown behaviour. It tolerated maximum heat fluxes of up to 3.9 W/cm^2 in a superfluid bath, more than twice the value tolerated by resonators B, C and E. In these arrangements entrances and exits of the helix tubes were situated at the same bath level. Obviously convection had forced the cooling mechanism of resonator D (18). The same observation could be

made at a bath temperature of 4.2 K where the cooling capacity was found to be even higher. This enabled stable high field operation and measurement of the high field Q's at a bath temperature of 4.2 K, too. Summarized shortly, breakdown field levels at 4.2 K proved equal or even higher than those measured in a superfluid bath. These observations support the idea to build an accelerator cooled by forced helium flow with a bath temperature of 4.2 K.

Influence of Static Magnetic Fields

Corresponding measurements have been carried out with A and D resonators. The additional losses, caused by a static magnetic field of the same strength as the earth's magnetic field, were of the same magnitude as the losses of our best resonator with magnetic shielding. One could consequently conclude that shielding need not be applied necessarily in an accelerator. However, the additional losses were increased by one order of magnitude at field levels of $E_p = 10$ MV/m (D). The question if magnetic shielding must be provided or not depends further on what part of the resonator becomes superconductive first. It is very likely that in the all-niobium resonator D the helix will effectively be shielded by its outer conductor whose transition to superconductivity will occur earliest. For the rather complex section E with different superconductor materials an influence of the static magnetic field on the high field Q's cannot certainly be excluded.

Conclusions

Summarized with respect to an application to accelerators we can conclude from our measurements:

1. High field Q values of 3×10^7 at 90 MHz can be obtained to date in helically loaded accelerating structures.
2. The corresponding accelerating fields in the low energy part of a proton accelerator ($\beta = 0.04$) enable energy gains of > 1 MeV/m increasing with particle speed.
3. Limitation of the energy gain is given by thermal breakdown of the helices, magnetic breakdown was not observed.
4. Field emission does not contribute to the losses at peak electric fields of up to 15 MV/m.
5. When higher accelerating fields are desired, improvements must be made on both, field emission properties and surface losses at the same time because both effects yield limitations at approximately the same field strength.

References

- (1) J. Halbritter, Z. f. Physik 238, 466 (1970)
- (2) J. P. Turneaure, I. Weissman, J. Appl. Phys. 39, 4419 (1969)
- (3) J. Halbritter, J. Appl. Phys. 42, 82 (1971)
- (4) M. Rabinowitz, SLAC TN-71-9, (1971)
- (5) L. Szecsi, Dissertation, University of Karlsruhe, (1970)
- (6) J. L. Fricke, B. Piosczyk, J. E. Vetter, this Conference
- (7) J. E. Vetter, B. Piosczyk, K. Mittag, R. Hietschold. Proc. of 1970 Proton Lin Acc. Conf., NAL, Batavia, Ill.
- (8) J. L. Fricke et al., Particle Accelerators 3, (1972)
- (9) A. Citron et al., Proc. Int. High Energy Acc. Conf., CERN, Geneva (1971)
- (10) A. Brandelik et al., submitted to Particle Accelerators, (1972)
- (11) F. M. Gardner, Phase Lock Techniques, Wiley, New York 1967
- (12) D. Schulze, Dissertation, University of Karlsruhe, (1971)
- (13) J. Halbritter, Particle Acc., 3, 163 (1972)
- (14) P. Ceperley, HEPL 655, HEPL Stanford, 1971, and private communication
- (15) R. Benaroya et al., Appl. Phys. Letters 21, 235 (1972)
- (16) G. Krafft, Proc. of the ICEC 4, Eindhoven, May 1972
- (17) M. Mc Ashan, Panel Discussion on rf Superconductivity, Proc. of Int. High Energy Acc. Conf., CERN, Geneva (1971)
- (18) G. Krafft, Kernforschungszentrum Karlsruhe, to be published

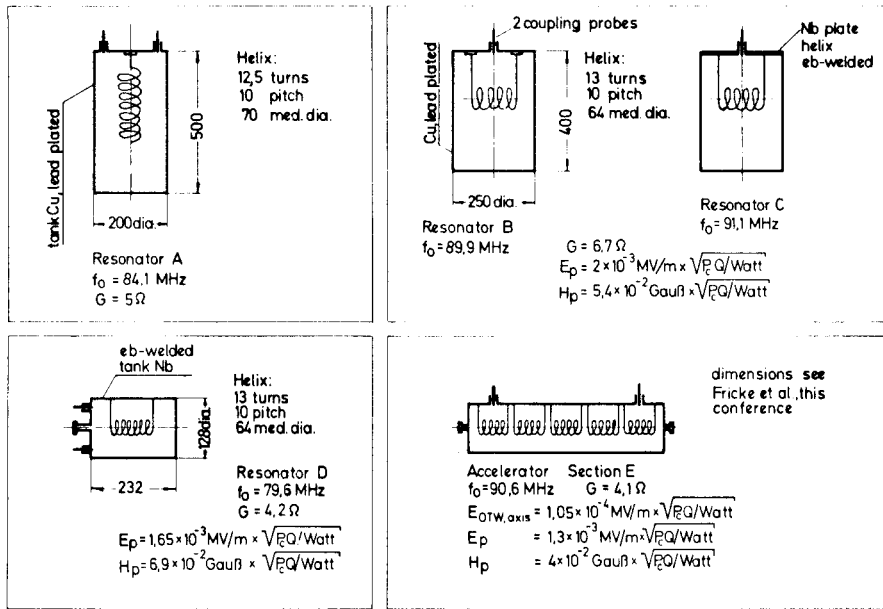

Fig. 1. Resonators A to E and their essential parameters.

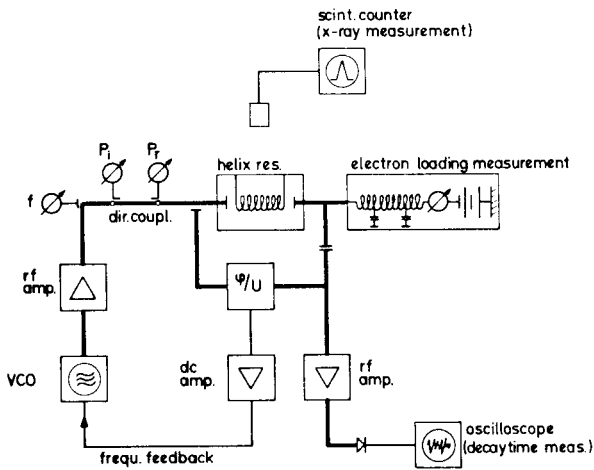

Fig. 2. Rf circuit.

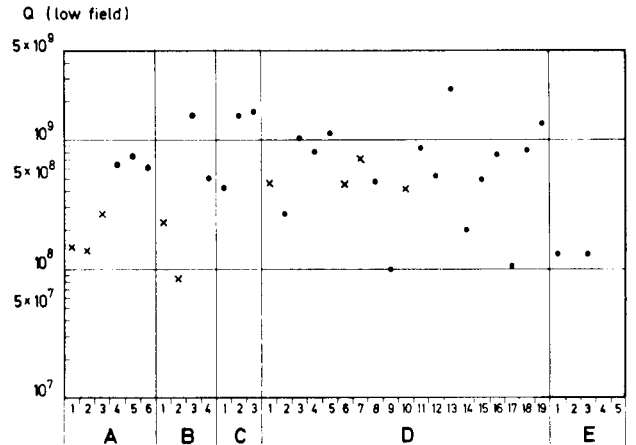

Fig. 3. Low field Q in different test runs.

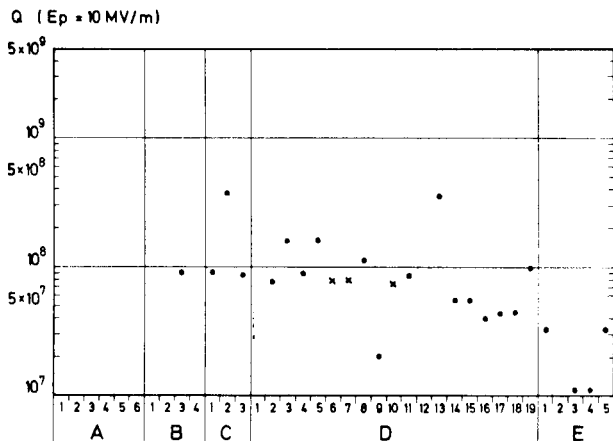

Fig. 4. Q at high field strength ($E_p = 10 \text{ MV/m}$) for resonators B to E.

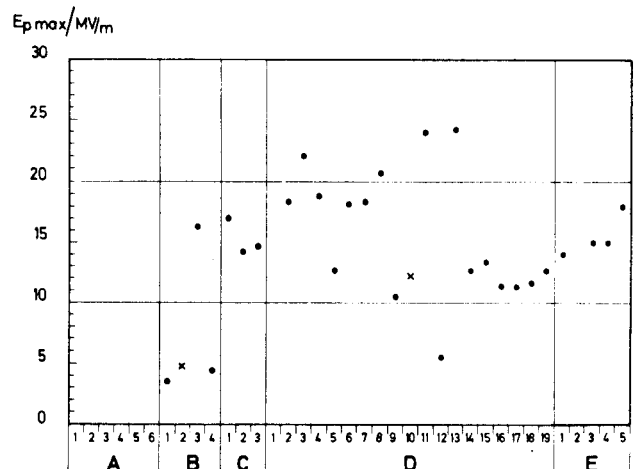

Fig. 5. Peak electric fields at breakdown for resonators B to E.

DISCUSSION

Claude M. Lyneis, Stanford Univ.: Can you explain the dependence of Q_0 on field level which is seen at 90 MHz but not seen at higher frequencies?

Vetter: I cannot explain it, but it is seen in all of our measurements. We have made measurements with very different shapes of cavities, and we have made measurements with all niobium cavities and with the "mixed technique" of lead and niobium. We always saw a more or less pronounced Q dependence. We cannot explain it.

Vetter: The picture is not always exactly the same. Sometimes you have more of a step in between and sometimes it is more smooth, but in principle it is the same. You start with a relatively high Q, and it degrades at power levels where it can hardly be explained as a thermal effect; because where these effects occur, the power is one-hundredth of the maximum power. It does not go with the power in the right way. All cavities show these degrading effects at relatively low power levels.

Bollinger: Let me just mention, as will be shown later in the talk by Ramler, we get a rather different shape in the same experiment, which is quite strange, I think.

Vetter: I know about that and I am interested to know first, what the details of your measuring process are and whether we can find any differences in what we are doing; and second, whether it could be possible that this degradation of Q was in the very, very low fields. I saw in the Argonne measurements that these were plotted only at higher fields. Probably there was a decrease at very low fields. Anyway, these values are quite nice. We have had one resonator that showed about the same behavior at high field as yours at Argonne.

Gregory A. Loew, SLAC: Is the 15 MV/m you quoted theoretical or measured?

Vetter: Do you mean the 15 MV/m in the structure?

Loew: Yes, the peak field.

Vetter: This is a combination of both a measurement and a calculation. The calculation is based on the sheath-model first and then on the Rink model to give the fields. Then we checked it by measuring long helices, because the end effects come in for a short helix. All calculations are made for an infinite length. To correct for the end-field effects we made measurements comparing peak fields in a short helix and in a very long helix.

Lyneis: Can you be sure that it is not electron loading?

Vetter: No, it is not likely to be electron loading. Electron loading occurs in two forms in our resonators; first multipacting and second, field emission.

Multipacting barriers, clearly separated from field emissions, occur at lower field levels. Then there is a region between where everything is nice, and then field emission occurs. It is not as mixed up as it is sometimes in cavity resonators with micro-waves.

Gregory A. Loew, SLAC: Did you at no time treat the niobium at high temperature?

Vetter: We did not do this because we are afraid that treating these helices at high temperature will have some disadvantages. First, that the tolerances cannot be maintained. Second, that you must suspend the helix and these suspensions will cause deterioration of the surface when you remove them. I am afraid that this heat treatment is useless, but we will try to make an experiment with one of our short cavities. I do not think it is very useful for the moment to go up to 1900°.

Loew: How about the anodizing technique, do you use that?

Vetter: Yes, as you have seen, the section was anodized and most of our single cavities were anodized. We also have, in fact, measurements without anodizing. The difference is mostly seen only in the low-field Q's. Anodizing seems to protect the surface in such a way that at low fields one gets higher Q's, up to 4×10^9 , e.g., whereas the best Q's in an un-anodized helix are about 7×10^8 . At high fields you always get about 7×10^8 independent of whether it was anodized or not. However, the coating may have some advantages, e.g., against oxidation, vacuum breakdowns or contaminations. We are now making experiments to see how good the protection against contamination is for various gases.

Loew: Do you find that after you have used an anodized helix that the electron bombardment damages it in some way or another?

Vetter: No, when we operate a section of a resonator for several days, the high field Q's and the breakdown are changed very little. What does change in the course of time is the amount of field emission. Sometimes you find a higher field emission level, then suddenly it decreases, sometimes very, very rapidly, but there is no permanent deterioration of the field strength. When the resonator is first measured, we have a high Q. Then to obtain high fields we must apply processing to pass through the multipacting effect. Then when the Q is measured, it is down by a factor of two or three. This is due to electron loading. It has nothing to do with field emission. Field emission seems not to affect the high-field Q values.

Lowell M. Bollinger, Argonne: Do I understand correctly that you get that same shape of Q vs axial field for the single half-wavelength units as for the 5-unit structure?