

Pulse-by-pulse Multi-XFEL Beamline Operation with Ultra-Short Laser Pulses

Toru HARA¹, Chikara KONDO², Takahiro INAGAKI¹, Kazuaki TOGAWA¹,
Hirokazu MAESAKA¹, Yuji OTAKE¹, Hitoshi TANAKA¹, Kenji FUKAMI²,
Shingo NAKAZAWA³, Taichi HASEGAWA³, Osamu MORIMOTO³,
Masamichi YOSHIOKA³, Yusuke KAWAGUCHI⁴, Hideaki KAWAGUCHI⁴

¹RIKEN SPring-8 Center, ²JASRI,

³SPring-8 Service Co., Ltd., ⁴Nichicon (Kusatsu) Corp.

Introduction



- SACLA started its operation with BL3 in 2011.
- User experiments since 2012.
- BL2 and installed in 2014.
- BL1 and SCSS+ installed in 2014.

- Three beamlines are currently in operation.
- BL1 for soft x-ray (20-150 eV), BL2 and BL3 for hard x-ray (4-15 keV).
- BL3 for unique operation mode, such as two-color XFEL and self-seeded XFEL.

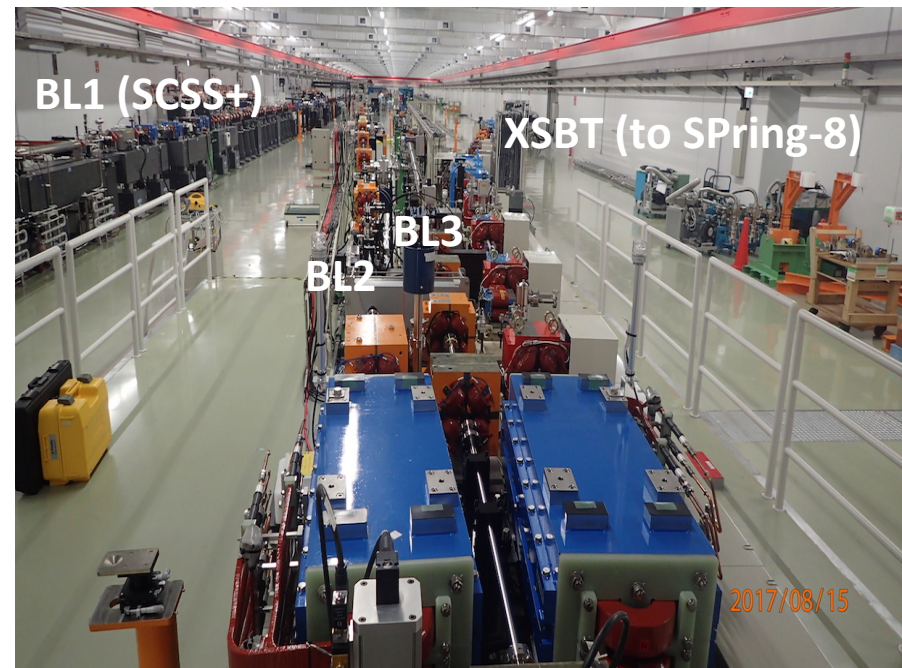

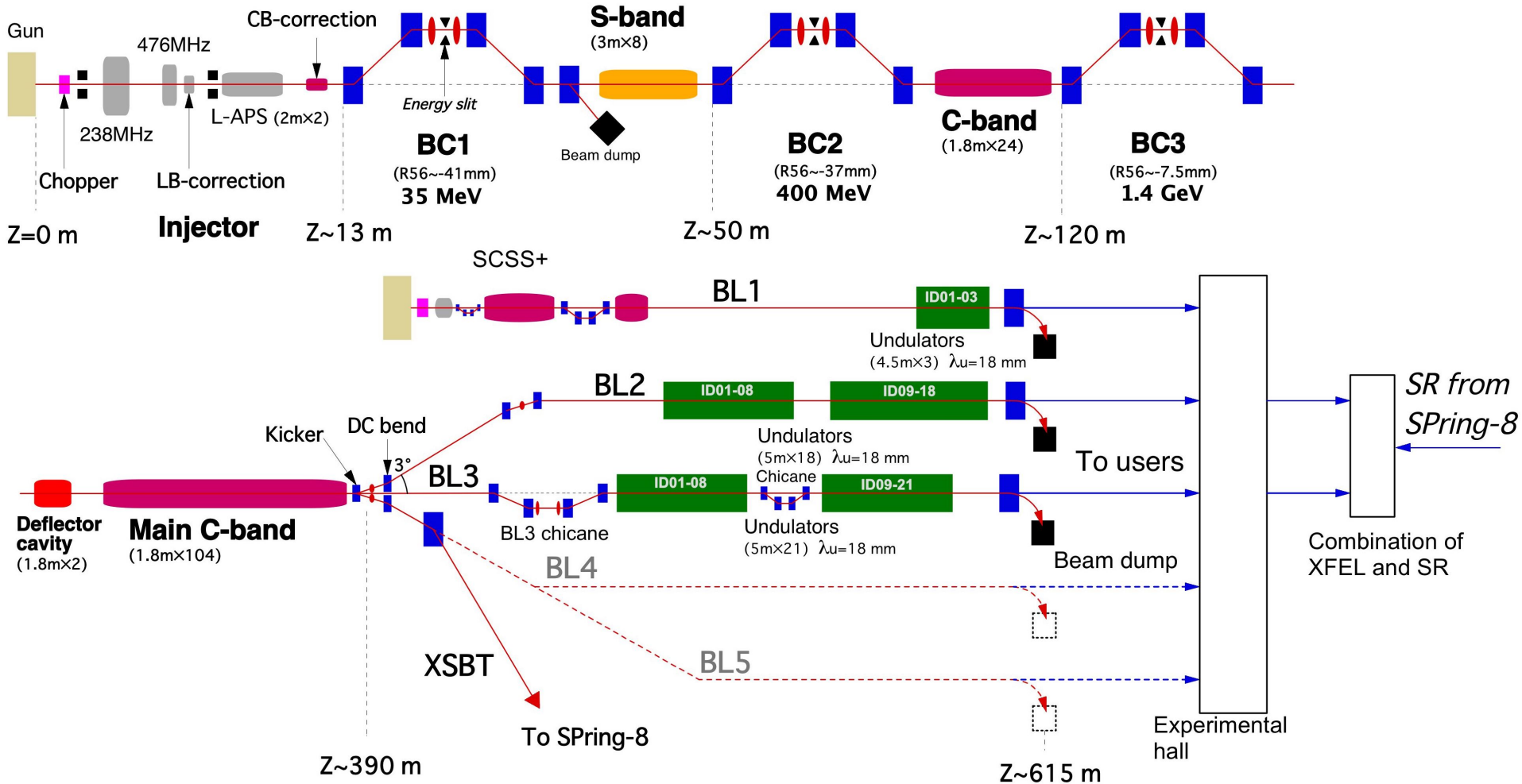

BL1: EUV and soft x-ray (20-150 eV)
BL2 and BL3: hard x-ray (4-15 keV)

Multi-beamline operation

Parallel operation of three beamlines to expand the opportunity of user experiments.

BL1 soft x-ray FEL	
Beam energy	800 MeV max.
Bunch charge	0.2-0.3 nC
Peak current	0.3 kA
Bunch length	< 1 ps (FWHM)
Repetition	60 Hz
Undulator period	18 mm
Undulator K value	< 2.1
Number of undulators	4.5 m x 3
Photon energy	20-150 eV
FEL pulse energy	0.1 mJ at 100 eV

BL1 is driven by SCSS+ accelerator.

BL2 and BL3 XFEL	
Beam energy	8.5 GeV max.
Bunch charge	0.2-0.3 nC
Peak current	> 10 kA
Bunch length	< 20 fs (FWHM)
Repetition	60 Hz
Undulator period	18 mm
Undulator K value	< 2.6
Number of undulators	5 m x 18 (BL2) 5 m x 21 (BL3)
Photon energy	4-15 keV
FEL pulse energy	0.6 mJ at 10 keV

BL2 and BL3 share the electron beam of SACLA main accelerator.

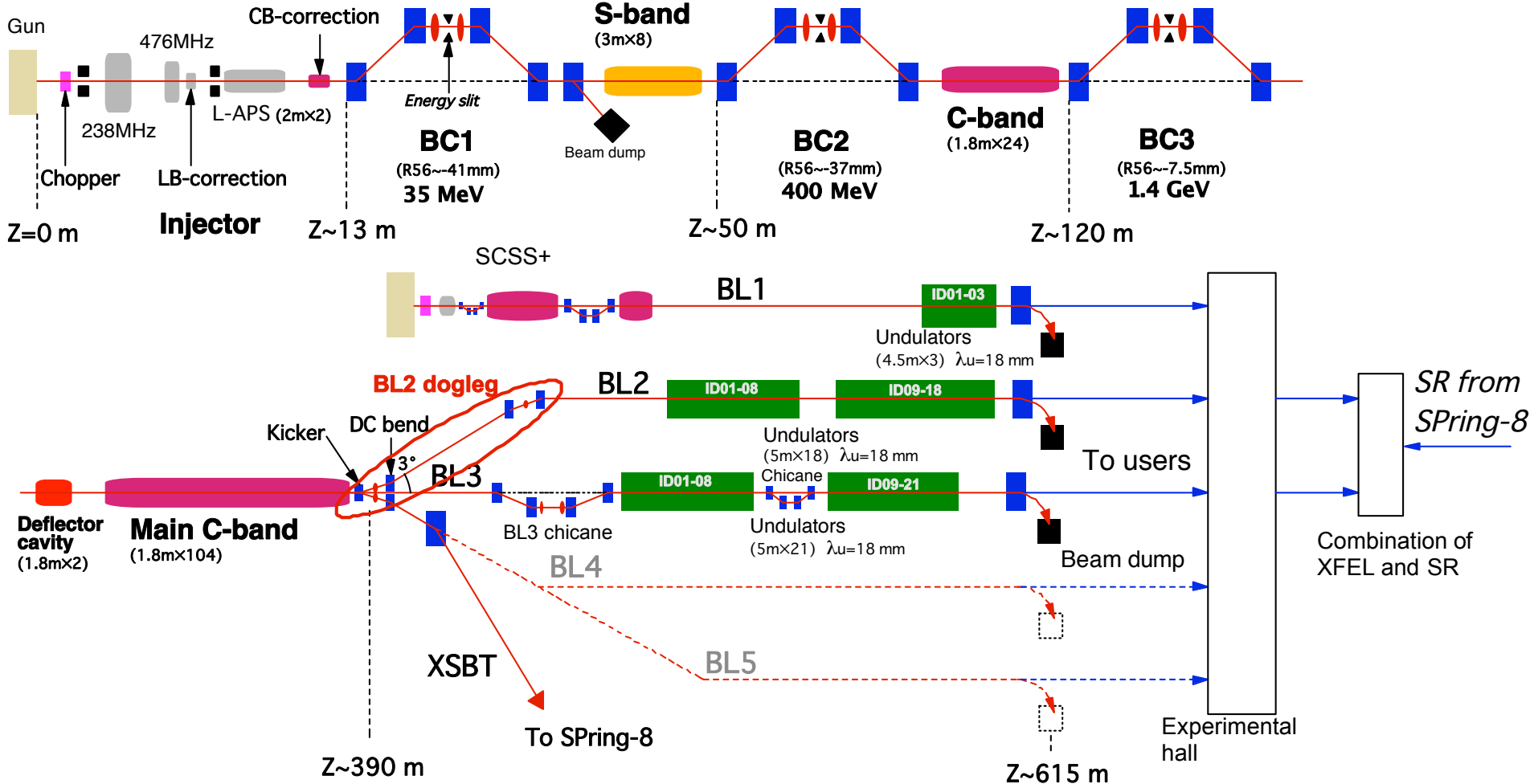

BL1: EUV and soft x-ray (20-150 eV)
BL2 and BL3: hard x-ray (4-15 keV)

Original design of BL2 dogleg

R_{56} of dogleg:

DC switching magnet 1.6 mm,
 kicker + septum without
 correction 4.0 mm,
 kicker + septum with correction
 0.07 ± 0.4 mm.

From linac

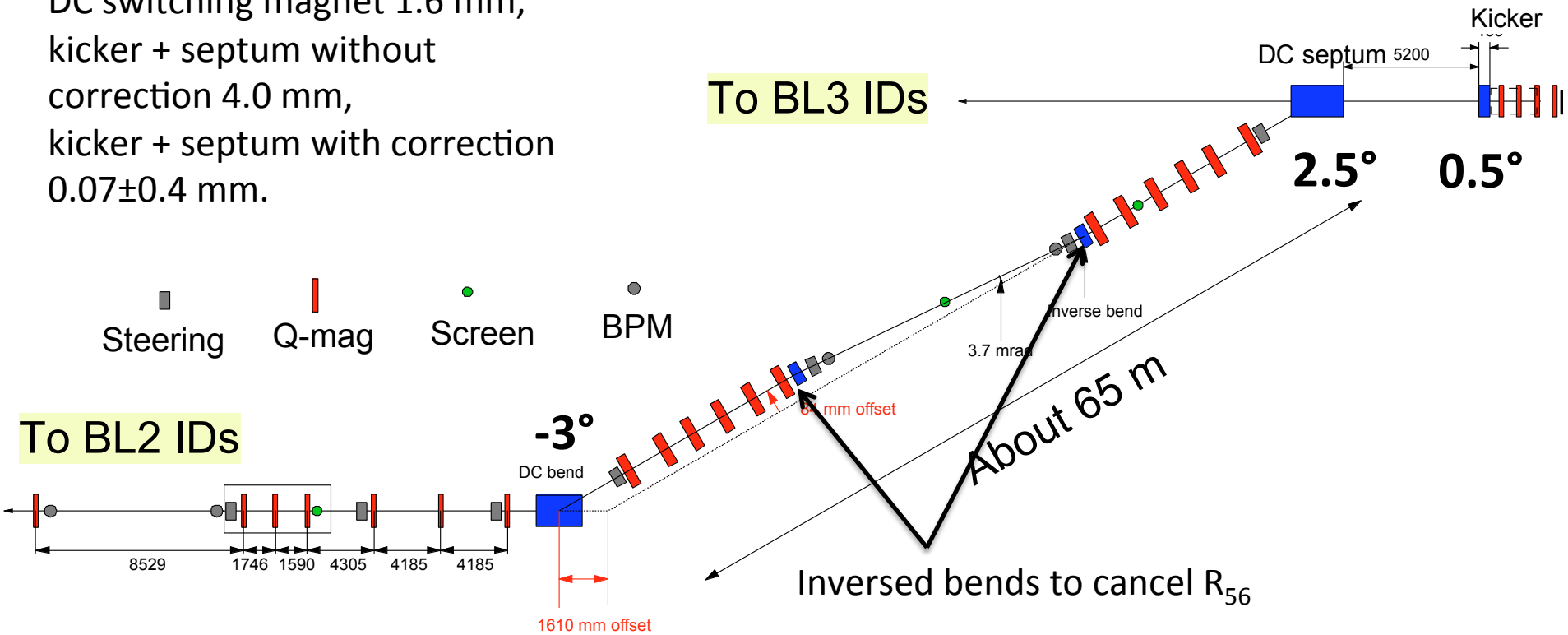

Deflection angle of the kicker was made as small as possible to ensure orbit stability. As a result, the cancellation of CSR effects was ignored.

CSR effects at the BL2 dogleg

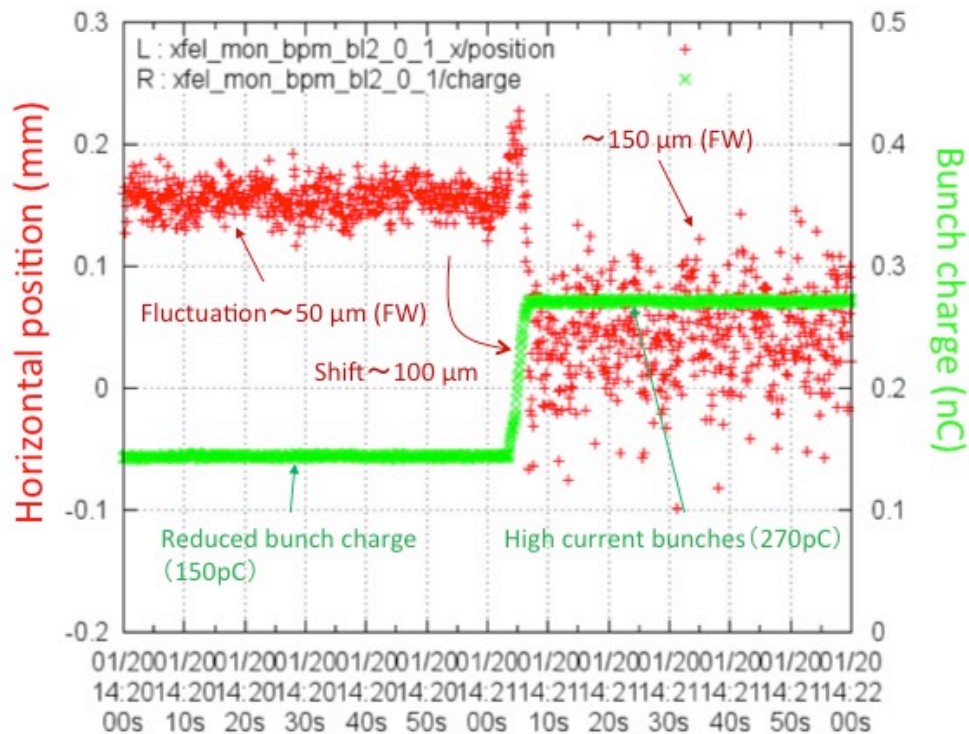

Horizontal orbit fluctuation after the dogleg.

- Lasing was obtained for 10 kA bunches, but with large orbit fluctuation.
- Transverse beam profiles are horizontally spread after the dogleg.

	Horizontal (pm-rad)	Vertical (pm-rad)
BL2 high current (10 kA)	16.3	0.74
BL2 low current (1 kA)	2.7	0.64
BL3 high current (10 kA)	1.4	0.27
BL3 low current (1 kA)	0.83	0.24

Emittance beam size is 33 pm-rad assuming 7.8 GeV and 0.5 μm-rad (norm. emit.).

Electron bunch profiles

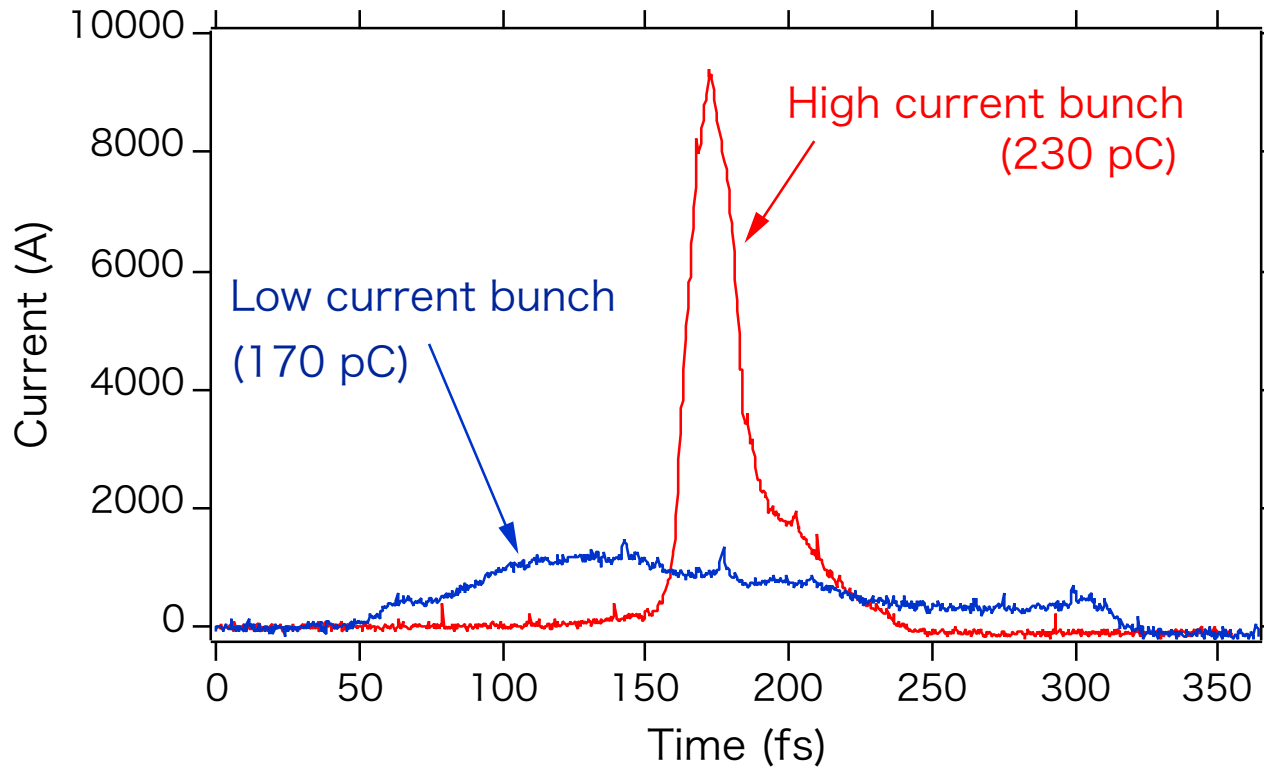

- Longitudinal electron bunch profiles measured by a C-band RF deflector (beam size not deconvoluted).
- High current bunch used for daily operation of SACLA BL3, ~10 kA.
- Low current bunch obtained after the parameter optimization for BL2, ~1 kA.

Replacement of the beam optics

• Old magnet configuration

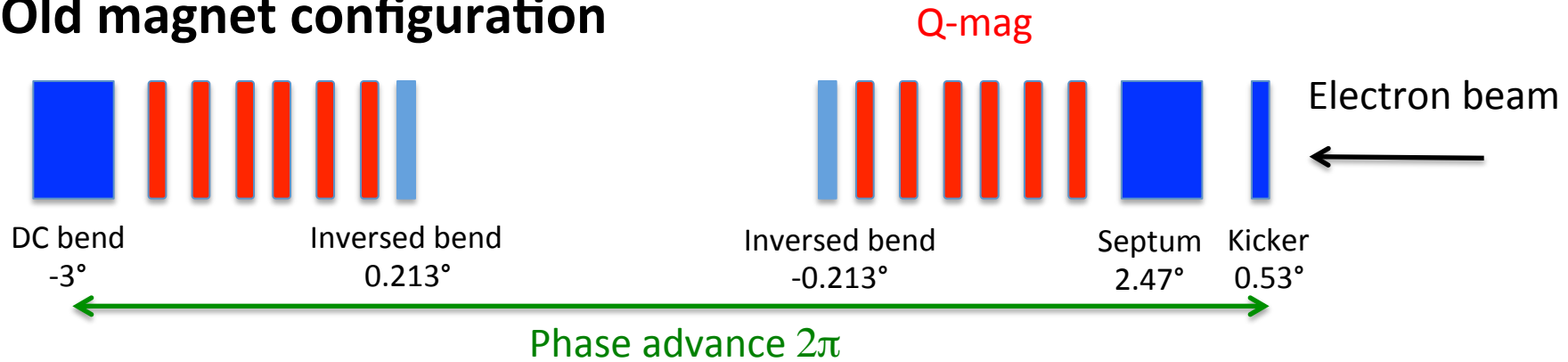

January 2017

• New magnet configuration (two DBAs)



To make R_{56} zero and maintain the same longitudinal bunch profile, the electron beam passes off-center of Q-mags at DBAs.

Beam optics functions

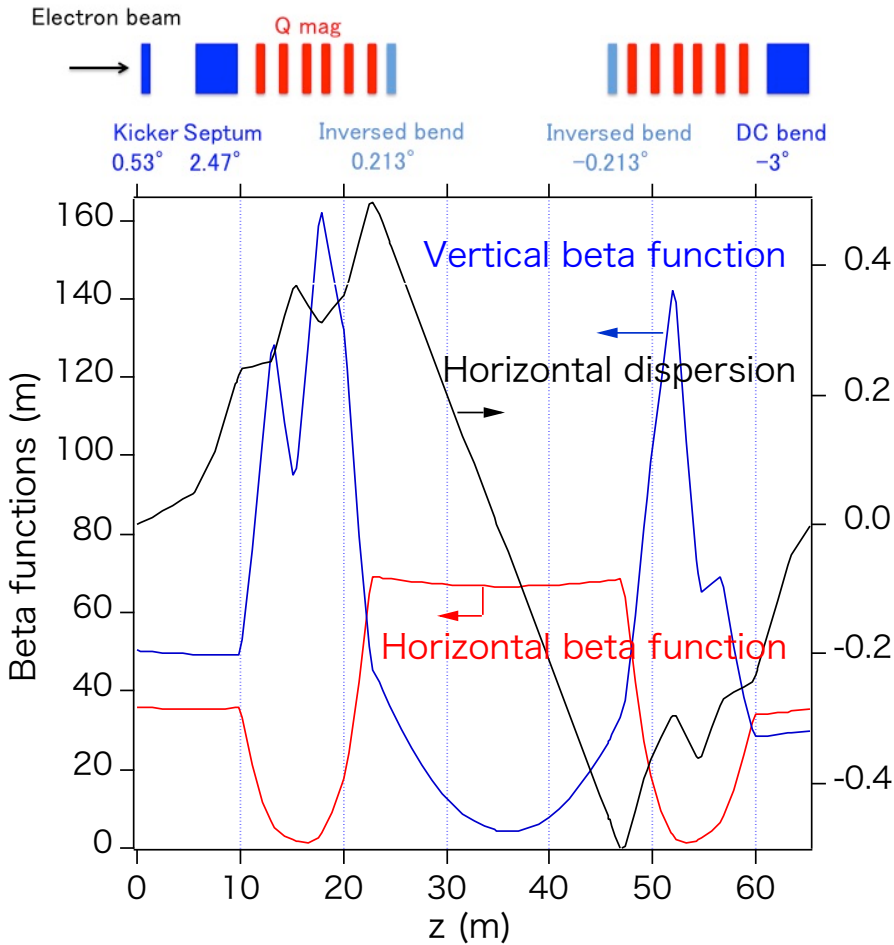

Old optics functions

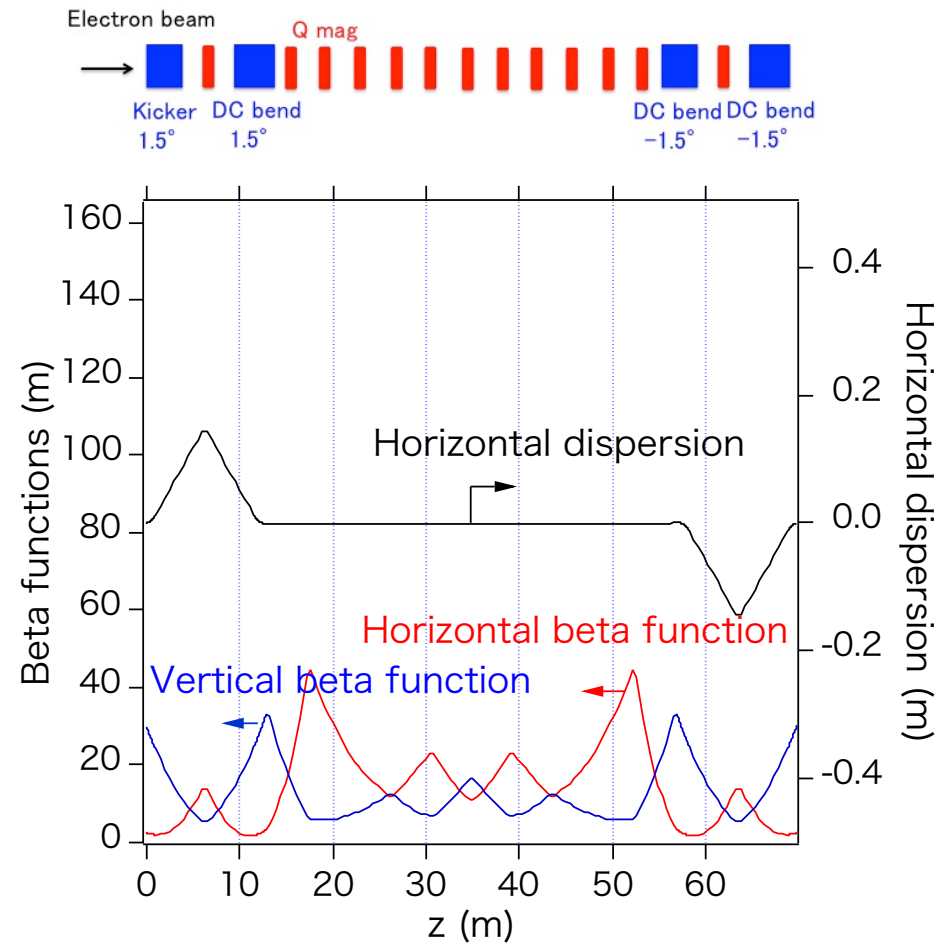

New optics functions

Small horizontal beta at bending magnets in new beam optics.

Pulsed power supply of the kicker magnet

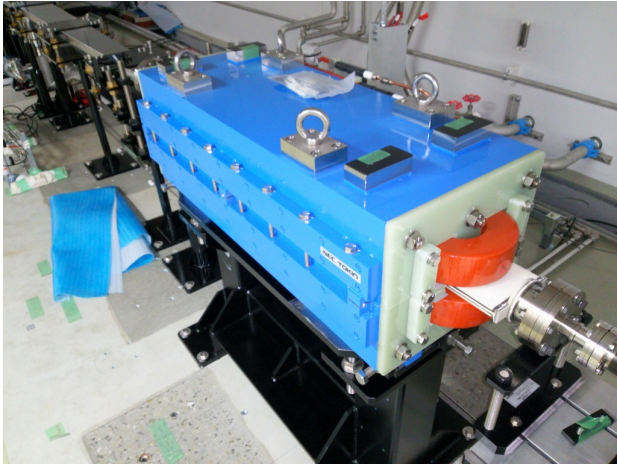

Kicker magnet
(Yoke length 0.95 m, $B_{\max}=0.9$ T)



Power supply (60 Hz, 1 kV-299 A)

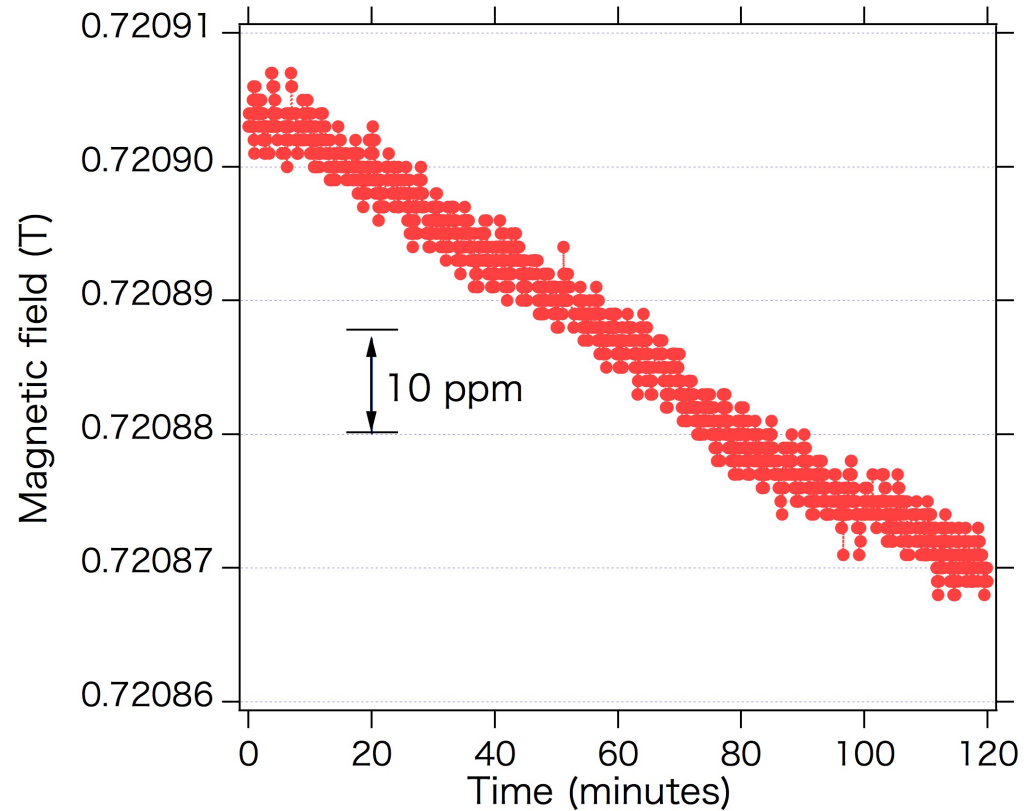

Stability of the kicker magnetic fields measured by a gated NMR.

SiC MOSFETs are used as switching elements.

Suppression of the CSR effects (simulations)

Old beam optics

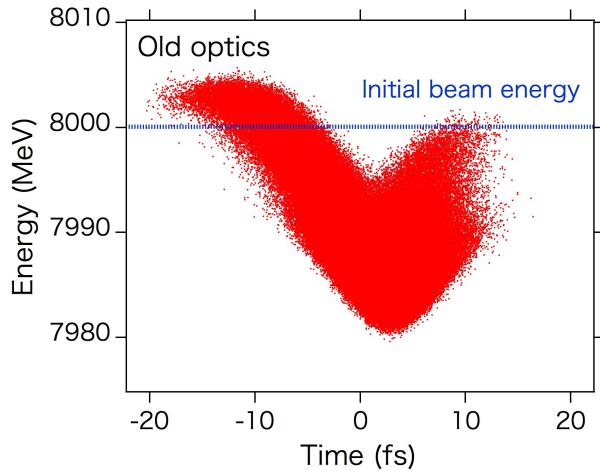

Energy deviation
after BL2 dogleg

Initial bunch conditions
Gaussian, 8 GeV,
10 fs (FWHM), 10 kA
0.8 mm-mrad.

New beam optics

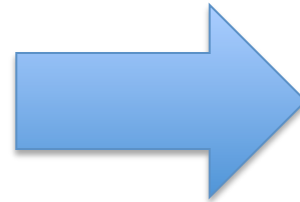
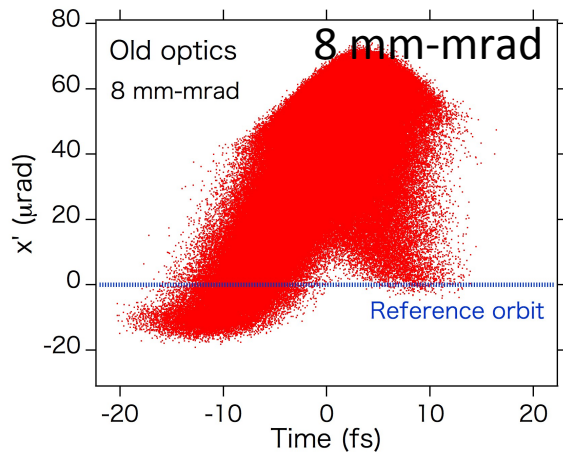
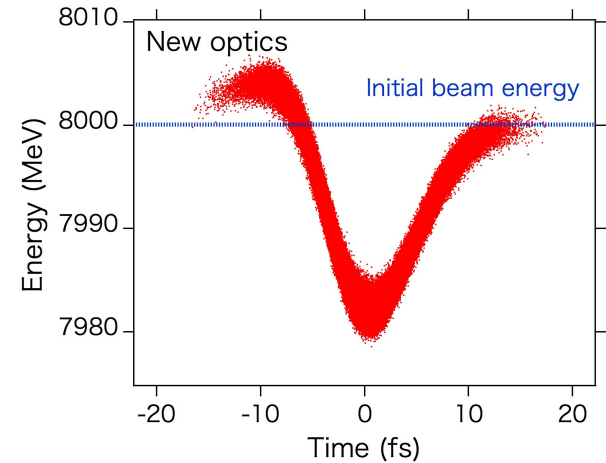

t - x' phase space
after BL2 dogleg

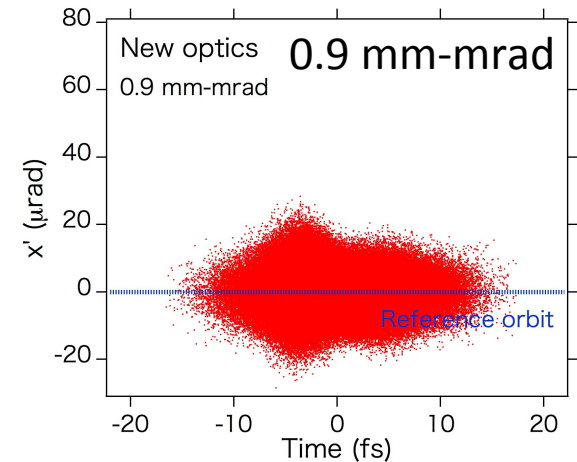

Projected emittance growth is about 10 % for the new beam optics.

Electron beam profiles at BL2

Electron beam 7.8 GeV, 10 kA

- Old beam optics

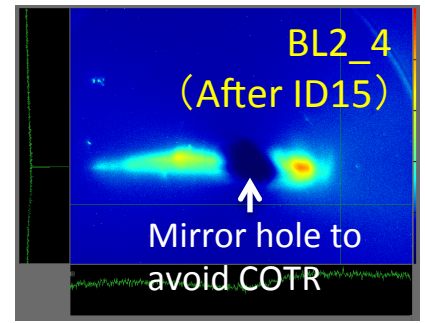
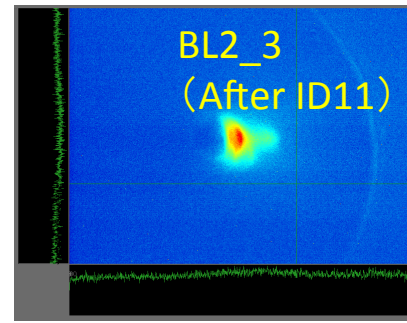
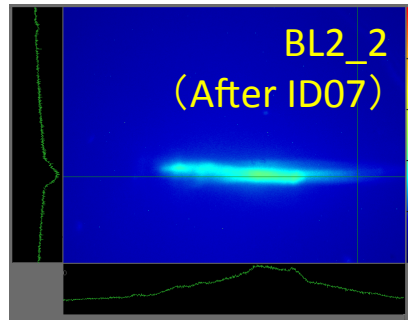
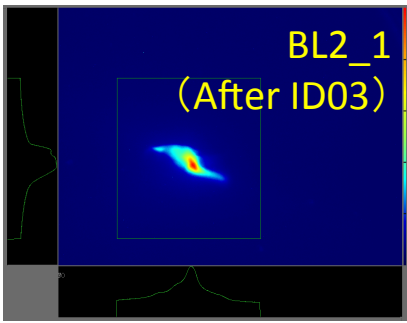

- New beam optics

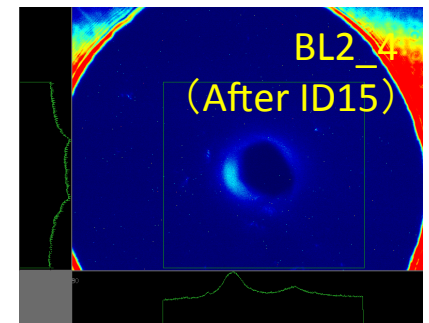
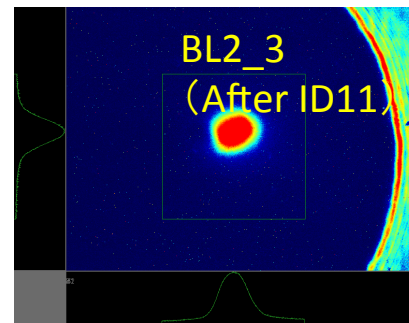
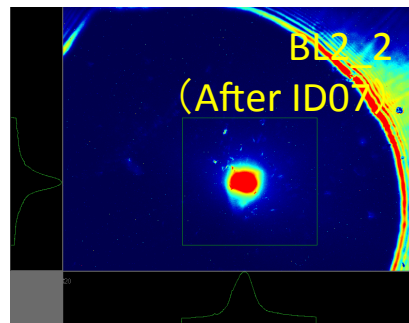
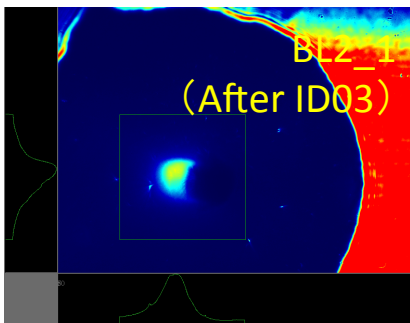

Suppression of the CSR effects (measured)

Old beam optics

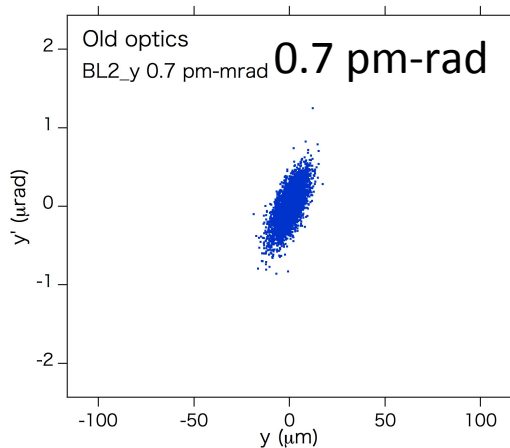
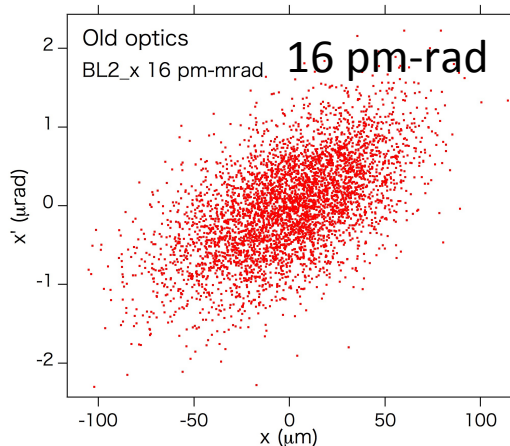

Horizontal orbit stability
after BL2 dogleg

Beam energy 7.9 GeV, peak current ~ 10 kA, bunch repetition 30 Hz, electron bunches are alternately sent to BL2 and BL3.

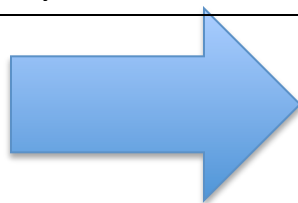

New beam optics

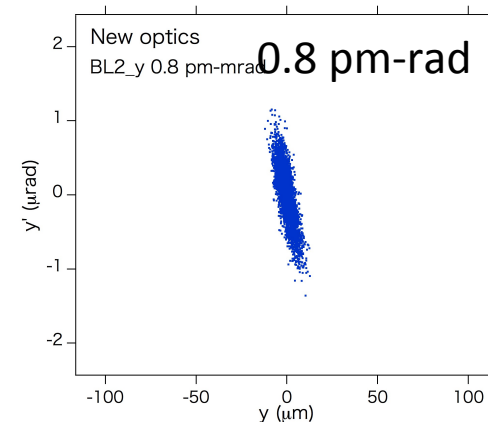
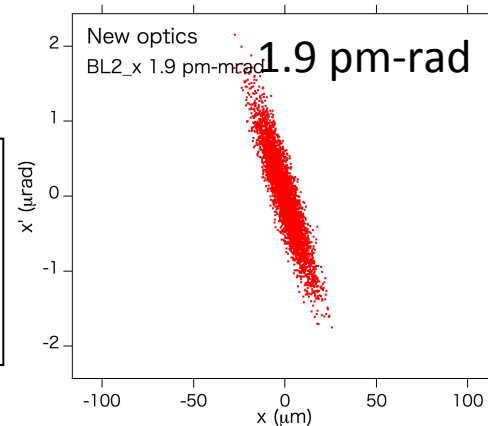

Vertical orbit stability

Orbit stability of BL3 is 0.8 pm-rad in horizontal and 0.5 pm-rad in vertical.

Horizontal orbit stability is improved by an order.
10 kA bunches are stably transported to BL2 through the dogleg.

Cancellation of CSR effects

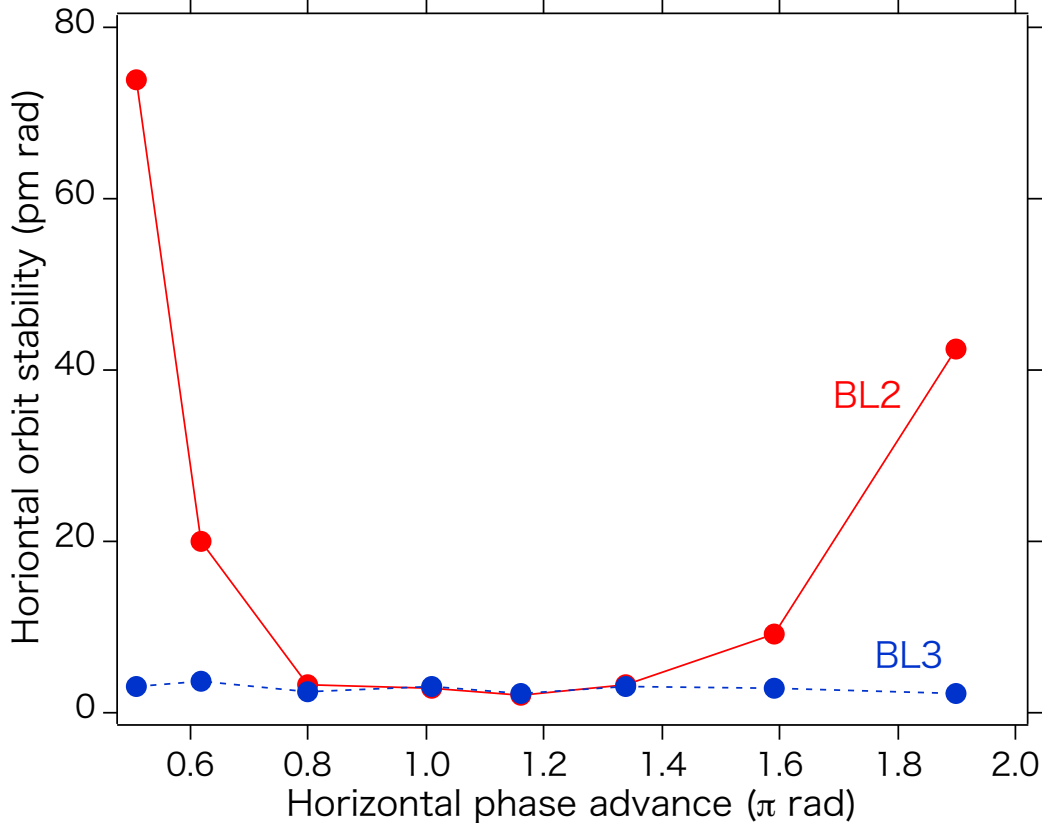
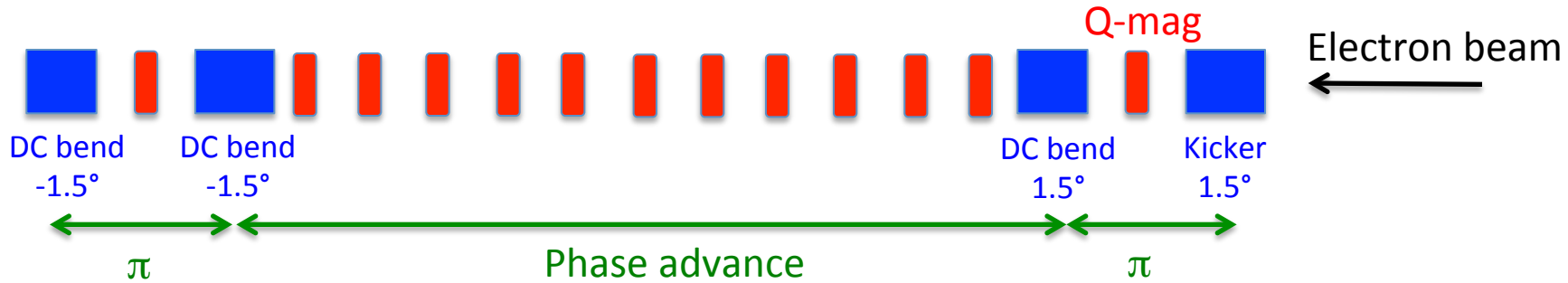

Electron beam orbit becomes unstable as getting away from π .

BL3 shows natural orbit stability of the accelerator.

Multi-beamline operation

60 Hz electron bunches are alternately deflected to BL2 and BL3.

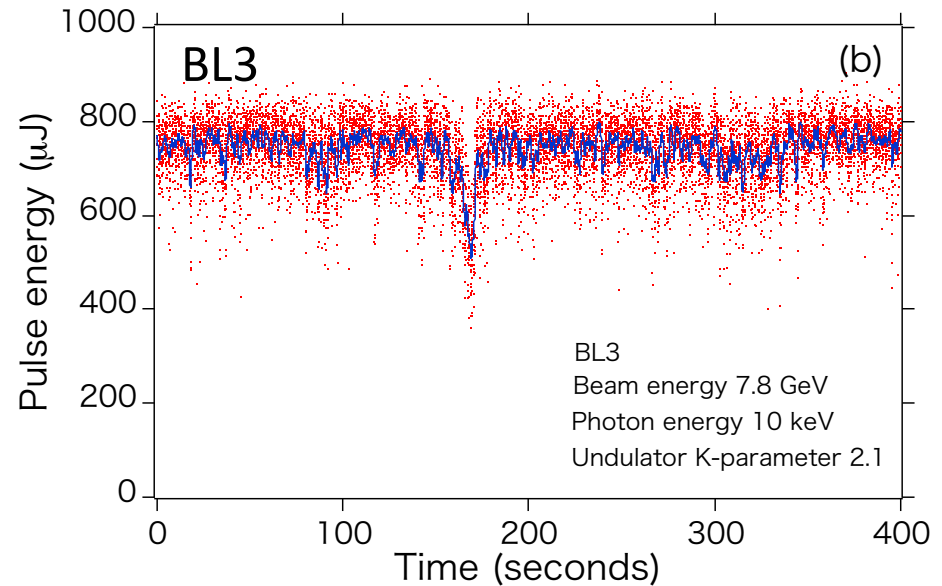
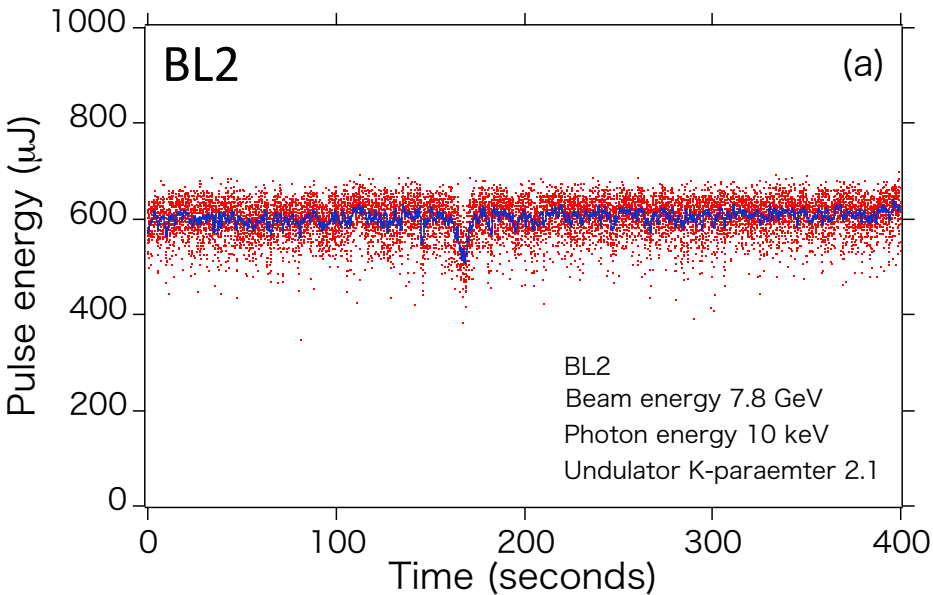

- The peak current is increased from 3 kA to 10 kA, consequently the laser pulse energy is also increased by a factor of 2-3.

SACLA accelerator

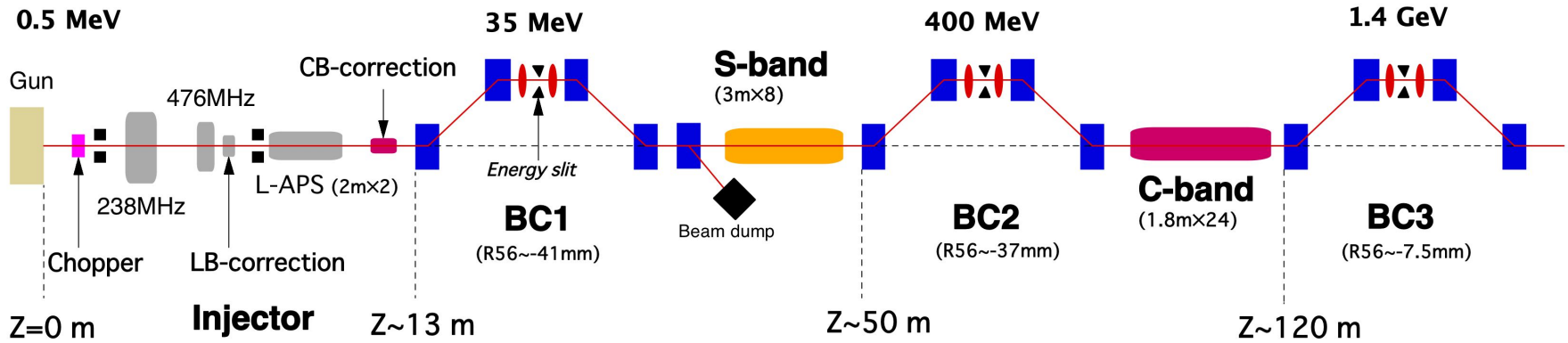

BL2 dogleg $R_{56}=0$

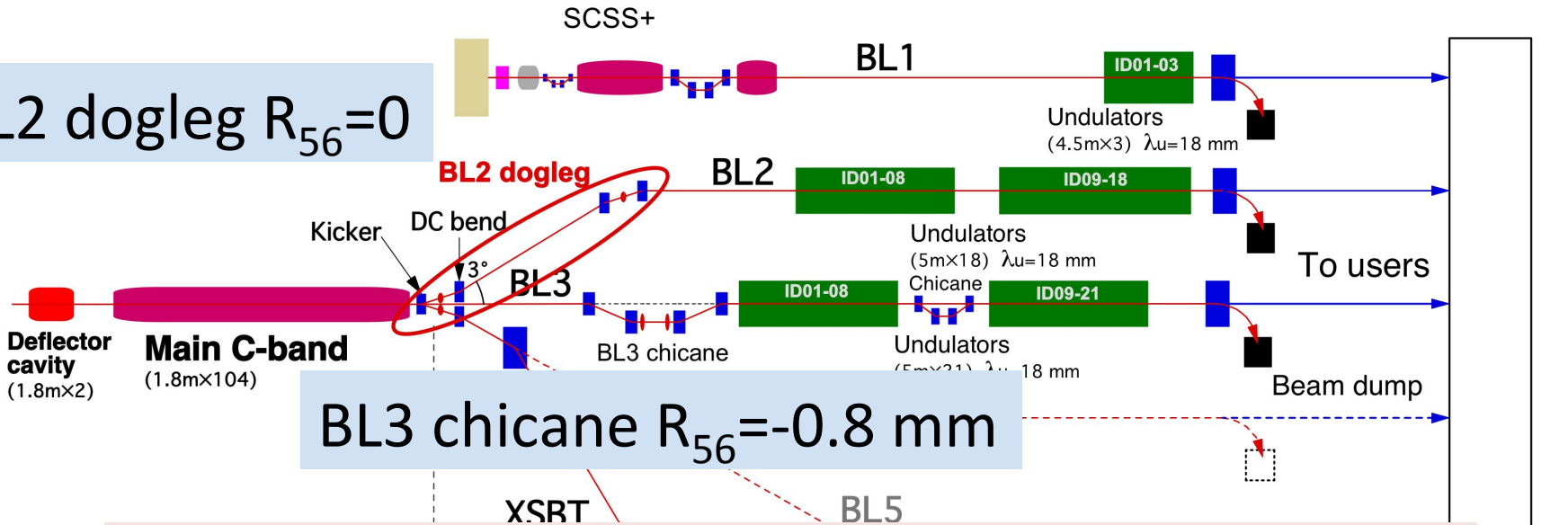

Optimum condition of the bunch compression is slightly different between the two beamlines.

Bunch to bunch RF phase control

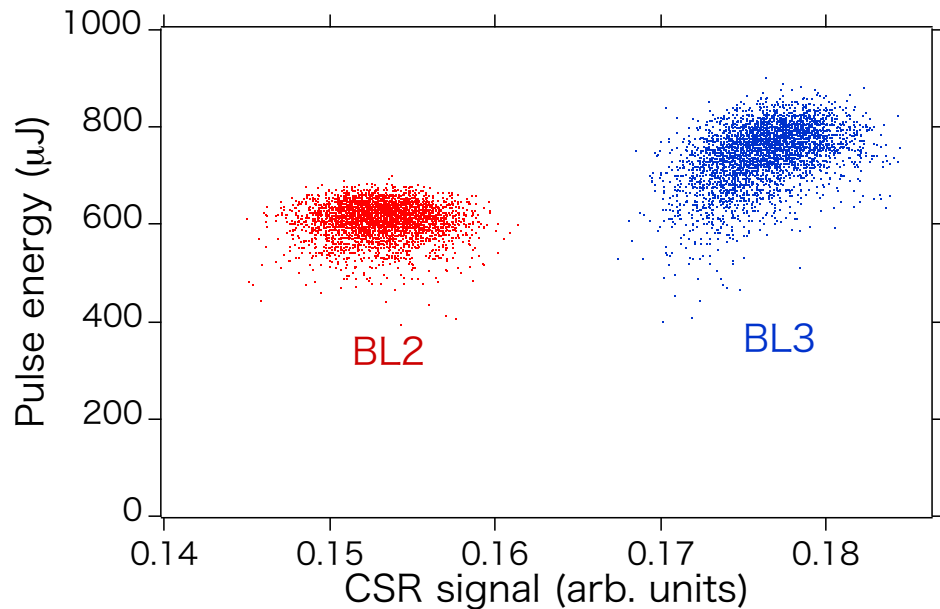

Laser pulse energy as a function of BC3 CSR monitor output.

Beam energy	BL2 7.8 GeV
	BL3 7.8 GeV
Undulator K-value	BL2 2.1
	BL3 2.1
Electron beam repetition	60 Hz
BL2 laser repetition	30 Hz
BL3 laser repetition	30 Hz

RF phase of 238 MHz cavity in injector

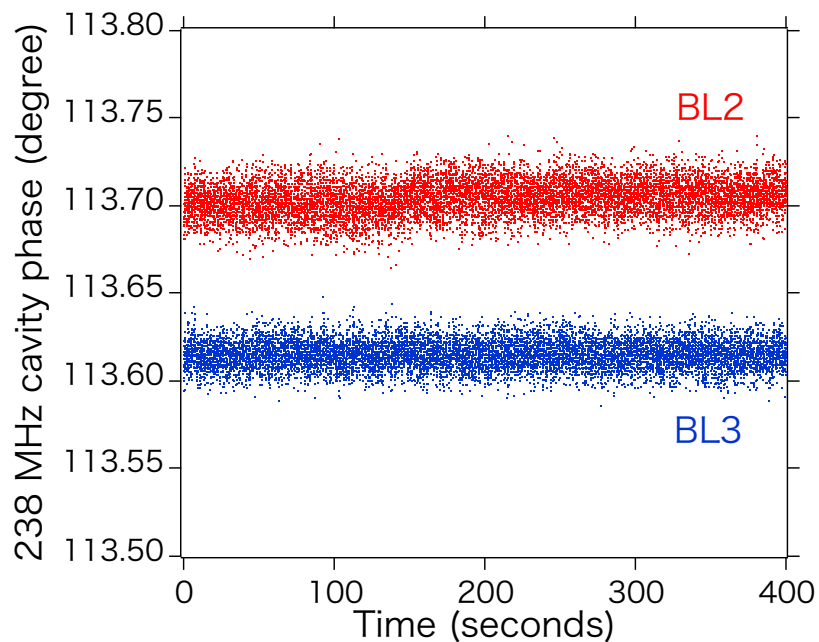

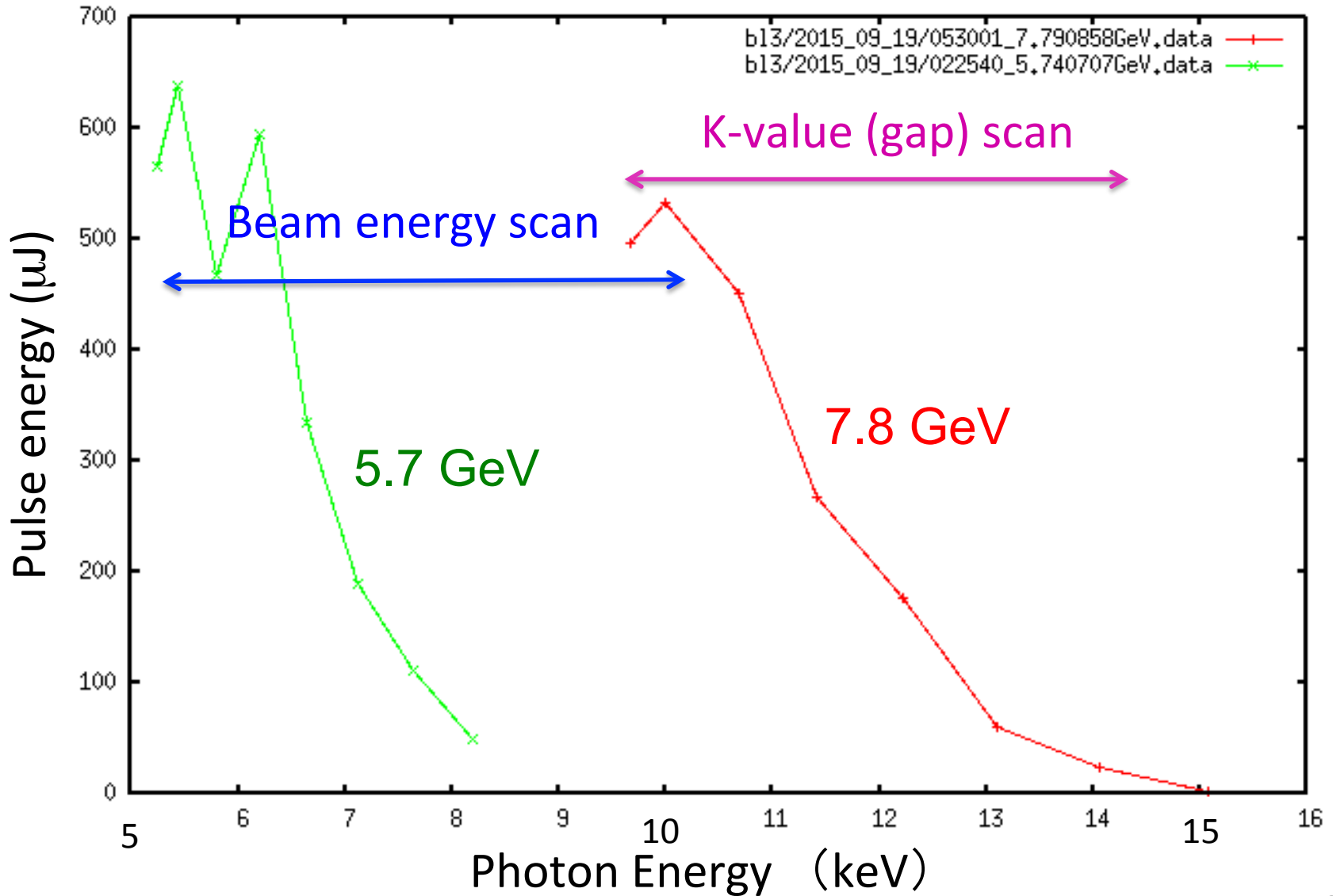

For wide spectral tunability of XFEL multi-beamline operation.

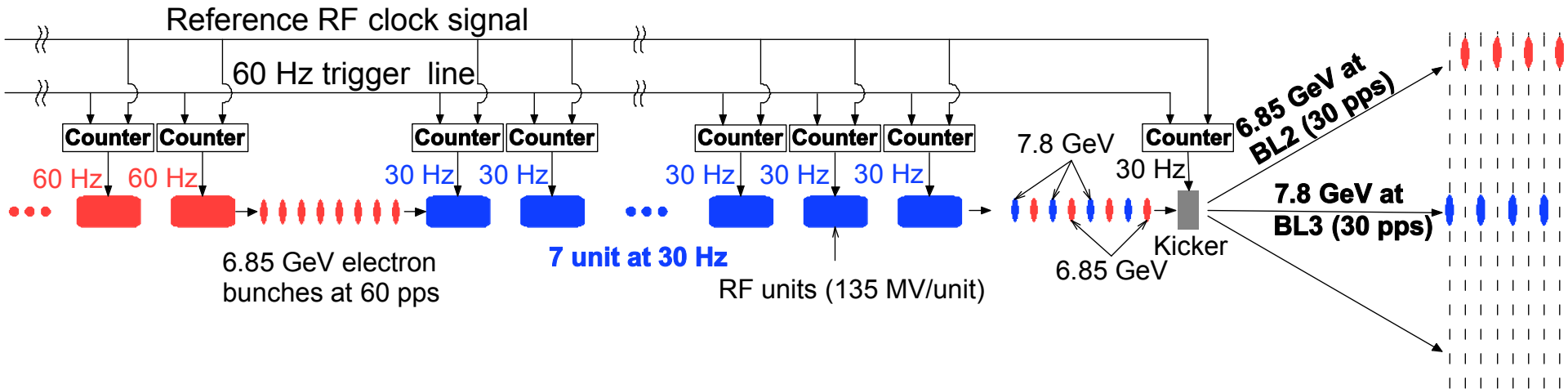

- Fourteen C-band accelerating structures downstream of BC3 are operated at 30 Hz.
- One half of the 60 Hz electron bunches are accelerated to 6.85 GeV and other half to 7.8 GeV.
- The kicker magnet deflect low energy bunches to BL2 and high energy bunches to BL3.

Multi-beamline operation

Low energy bunches (6.85 GeV) are deflected to BL2 and high energy bunches (7.8 GeV) to BL3.

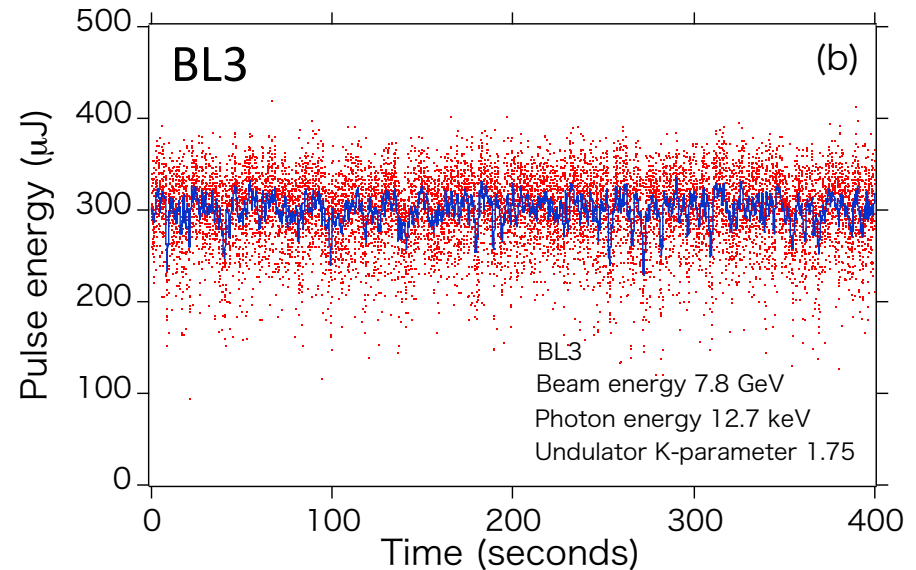
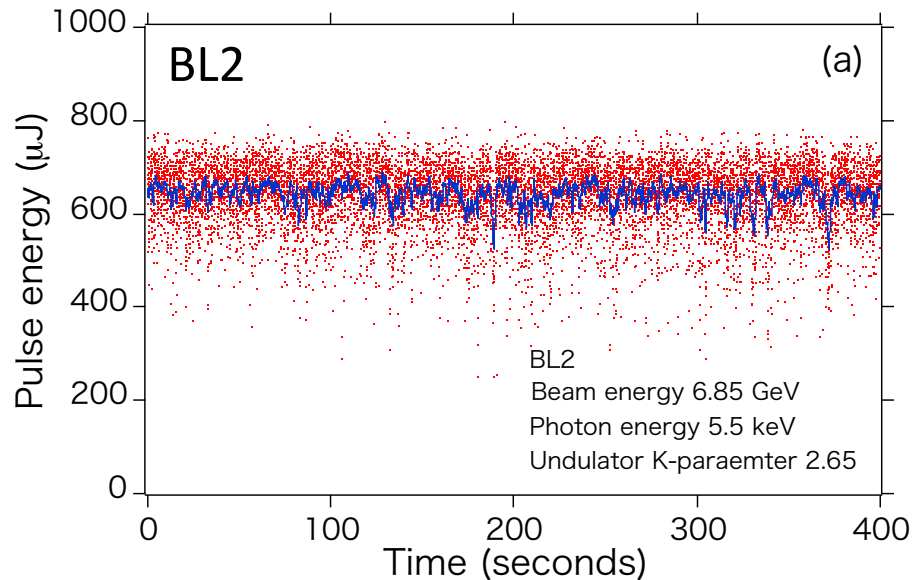

- Photon energies are more than twice different between BL2 (5.5 keV) and BL3 (12.7 keV).

BL1 soft x-ray FEL (SCSS+)

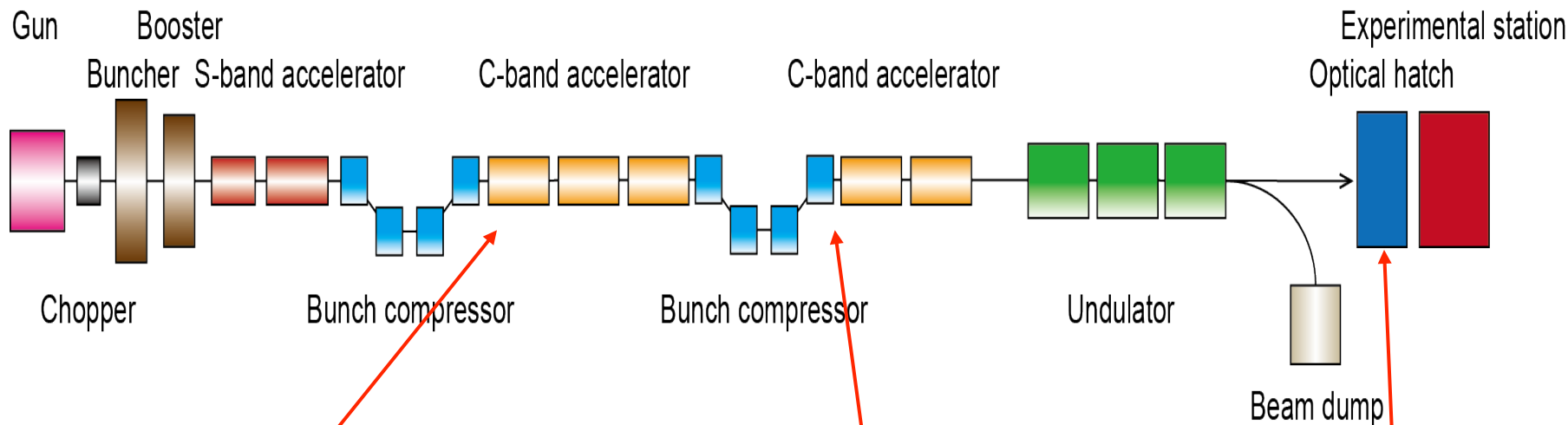

Measured Laser Profile @12nm

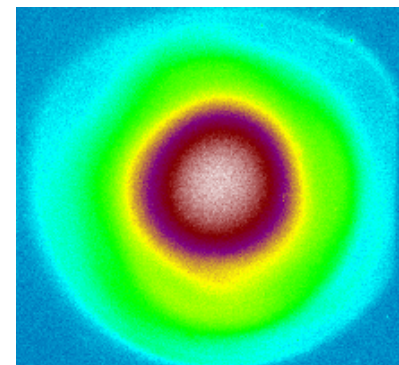

Measured Current Dist.

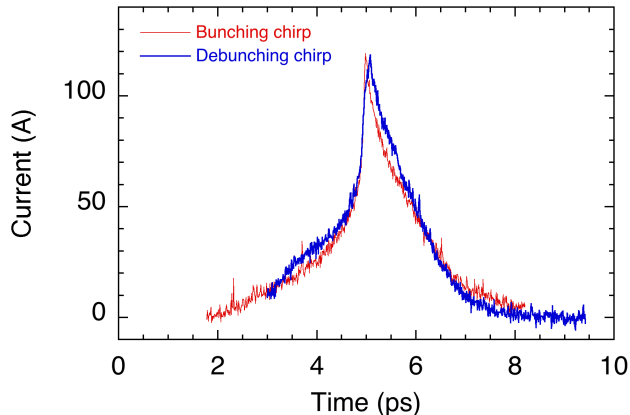

Simulated Current Dist.

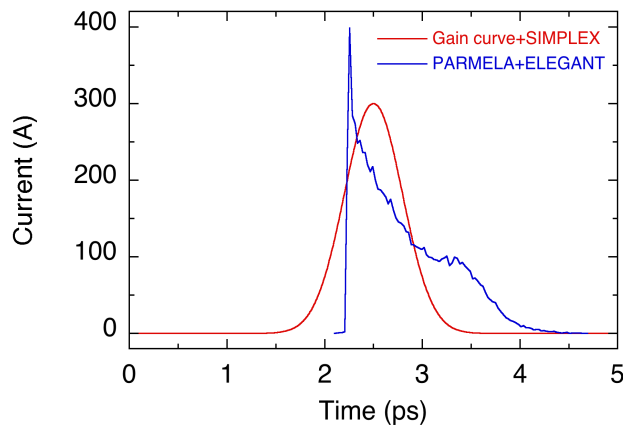

BL1 soft x-ray FEL (SCSS+)

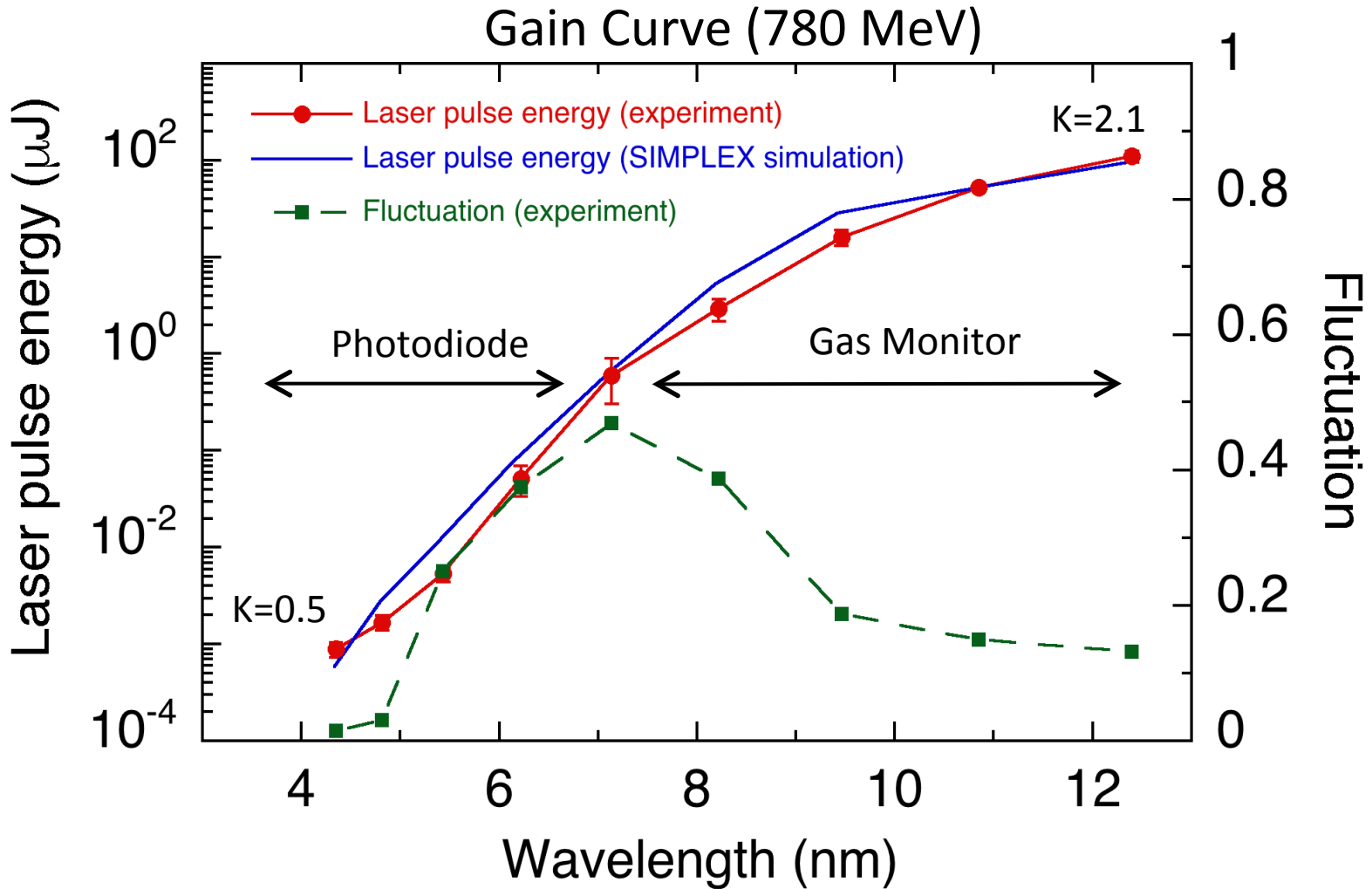

Peak Current of 300 A and slice emittance of 0.5 mm-mrad is expected.

BL1 soft x-ray FEL (SCSS+)

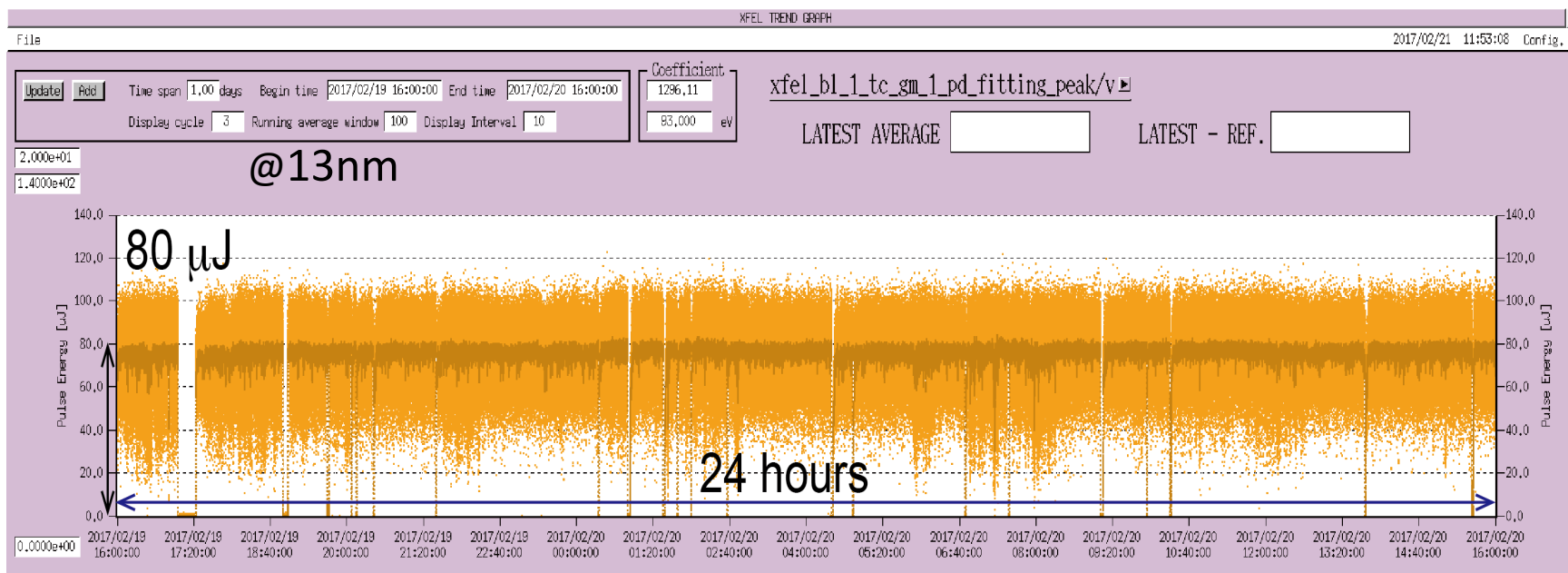

Since September 2016, BL1 soft x-ray FEL has been open to users with a spectral range from 20 eV (60 nm) to 150 eV (8nm).

Summary

- The parallel operation of the three beamlines substantially expand the opportunity of user experiments (more than 6000 hours user time is foreseen FY2018).
- BL1 covers EUV and soft x-ray (20-150 eV) driven by a dedicated 800 MeV linac.
- BL2 and BL3 are hard x-ray beamlines (4-15 keV) share the electron beam of the SACLA linac pulse by pulse.
- BL2 is used for the experiments using established technique (SFX, CDI...) or high power optical laser.
- BL3 provides unique operations, such as two-color XFEL, self-seeded XFEL...
- The methods and techniques developed for the multi-beamline operation will be applied to the beam injection from SACLA to SPring-8 in future.