



# Impact of a Wideband Feedback Prototype System on TMCI in the SPS

H. Bartosik, E.R. Bjorsvik, W. Höfle, G. Kotzian, T.E. Levens, K.S.B. Li

CERN

J.E. Dusatko, J.D. Fox, C. H. Rivetta

SLAC

O. Turgut, Stanford University

The realisation of the SPS prototype transverse Wideband Feedback system has been a multi-laboratory effort in the frame of the US-LARP program and the SPS-LIU project at CERN.

The contributions from co-workers from SLAC, LBNL, and INFN are gratefully acknowledged.



# Outline

- Motivation for Wideband SPS transverse feedback
- Principle and realisation of prototype system “demonstrator”
- Multi-bunch and single bunch results
- Outlook - conclusions



# Motivation for Feedback: SPS as LHC Injector

- SPS operates as LHC injector accelerating protons from 26 GeV/c to 450 GeV/c
  - currently provides up to 288 Bunches per injection into LHC,  $1.3e11$  proton per bunch
- High-lumi upgrade for LHC foresees SPS to deliver  $2.3e11$  per bunch
  - requires single bunch intensities of  $2.6e11$  at SPS injection
  - Limitations today include transverse instabilities that are addressed by the LHC Injector Upgrade program (LIU)
- SPS operates with coupled bunch transverse feedback (20 MHz bandwidth)
  - damps well dipolar oscillations, upgraded in 2014
- intra-bunch oscillations also observed
  - electron cloud driven
  - impedance driven
- possible mitigation by
  - high chromaticity
  - change of optics: lower gamma transition  $\rightarrow$  higher threshold of instability (Q20, Q22, Q26)
  - feedback  $\rightarrow$  prototype system “demonstrator” developed and deployed

# Motivation and History of SPS intra-bunch Feedback

- Study to mitigate intra-bunch vertical oscillations by feedback started in 2007
- originally motivated by vertical electron cloud driven instability (ECI)
- potential to mitigate impedance driven transverse mode coupling instability (TMCI) recognised from the start

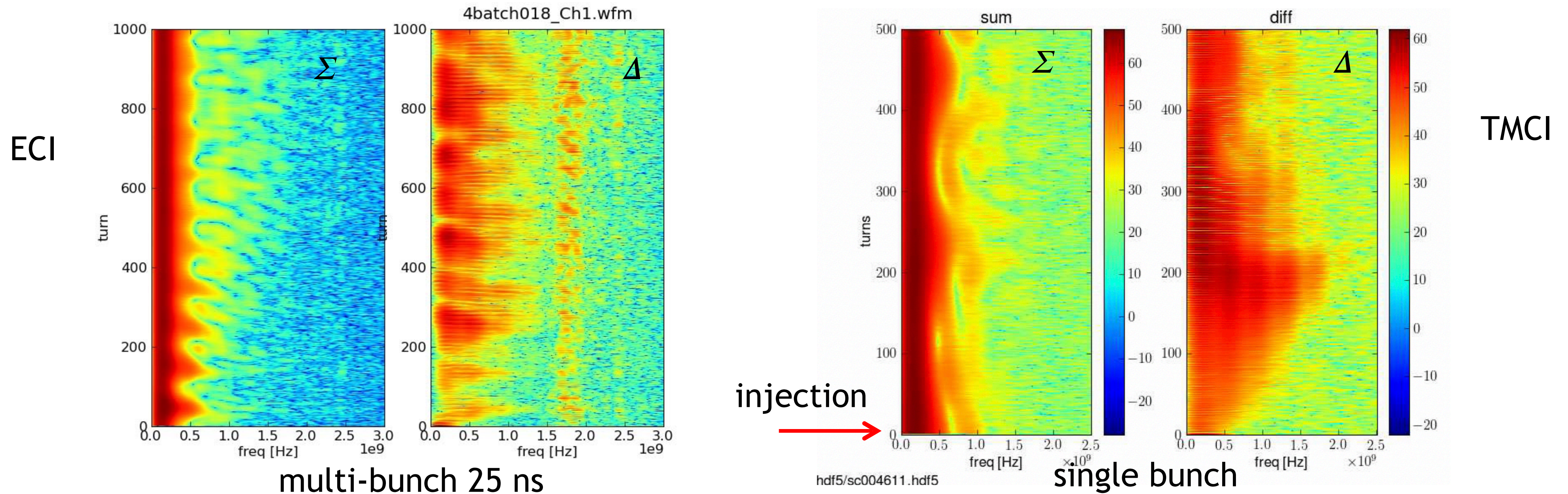

Pick-up signals: evolution of spectra of vertically unstable bunches at SPS at injection: 26 GeV/c

# Principle of Wideband Feedback

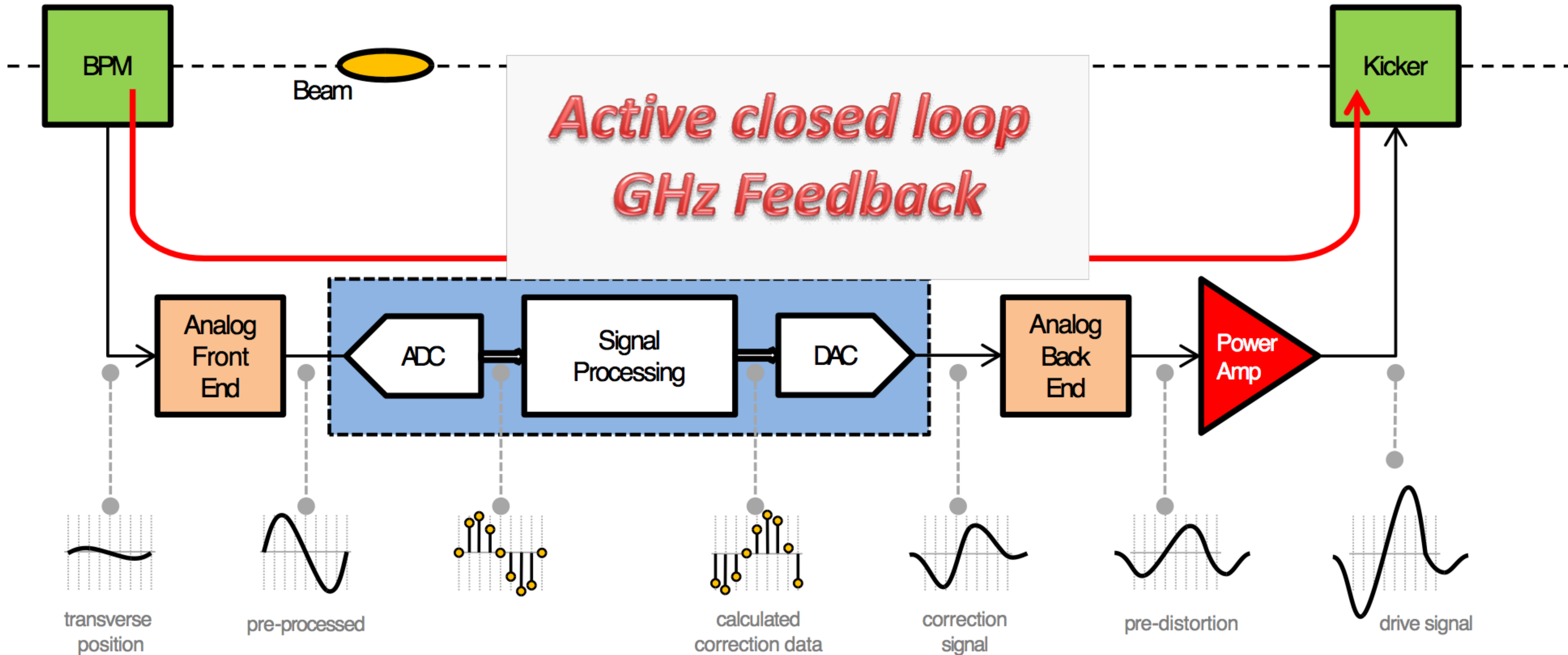

# Numerical Simulations in Q26

- Numerical simulations show the feasibility of feedback to cure the instabilities
- typically done at CERN using the Headtail Code
  - model of machine impedance integrated
  - feedback applied slice-by-slice within the bunch
  - Actual signal processing (e.g. FIR filters) can be integrated in simulation

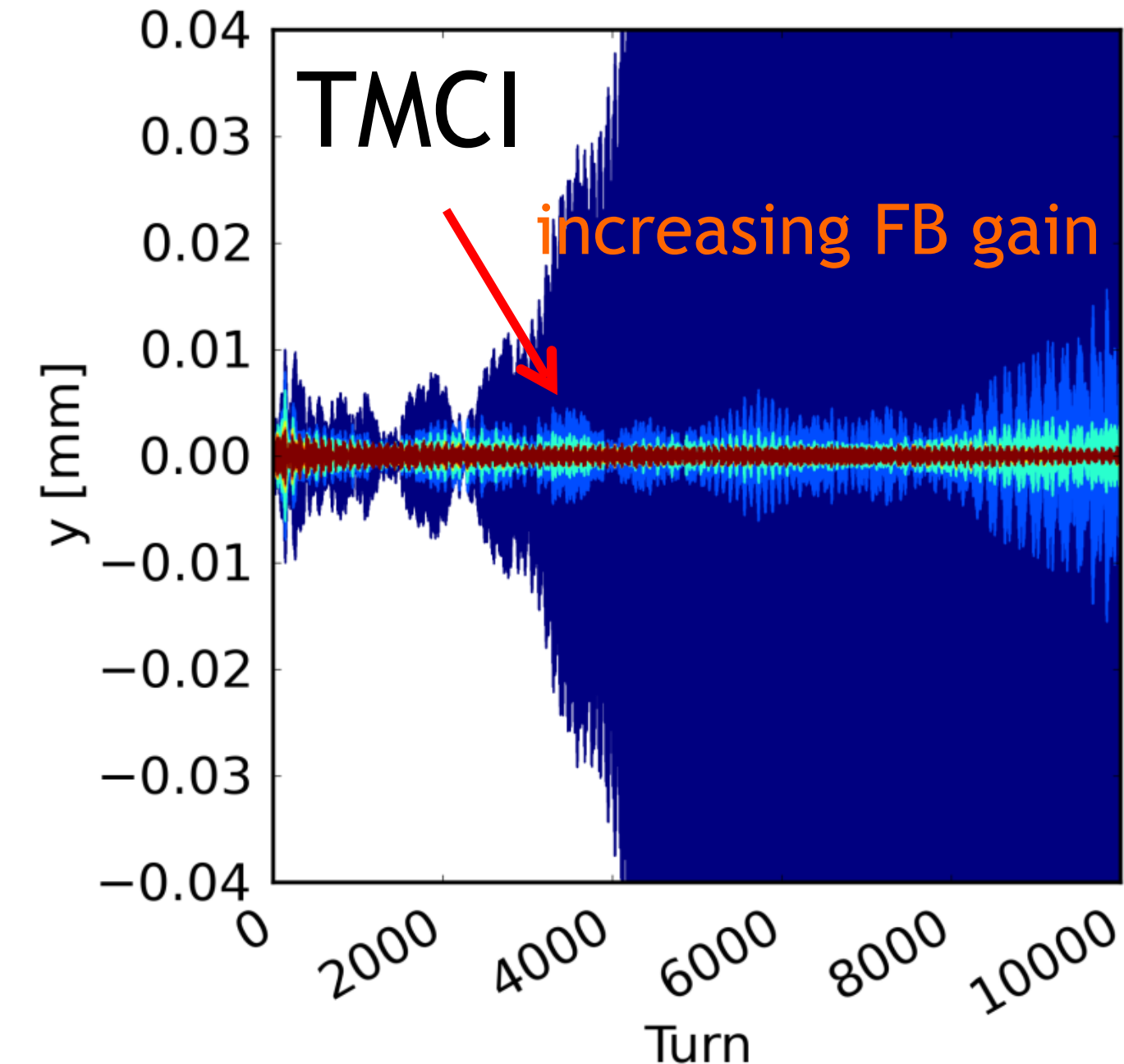
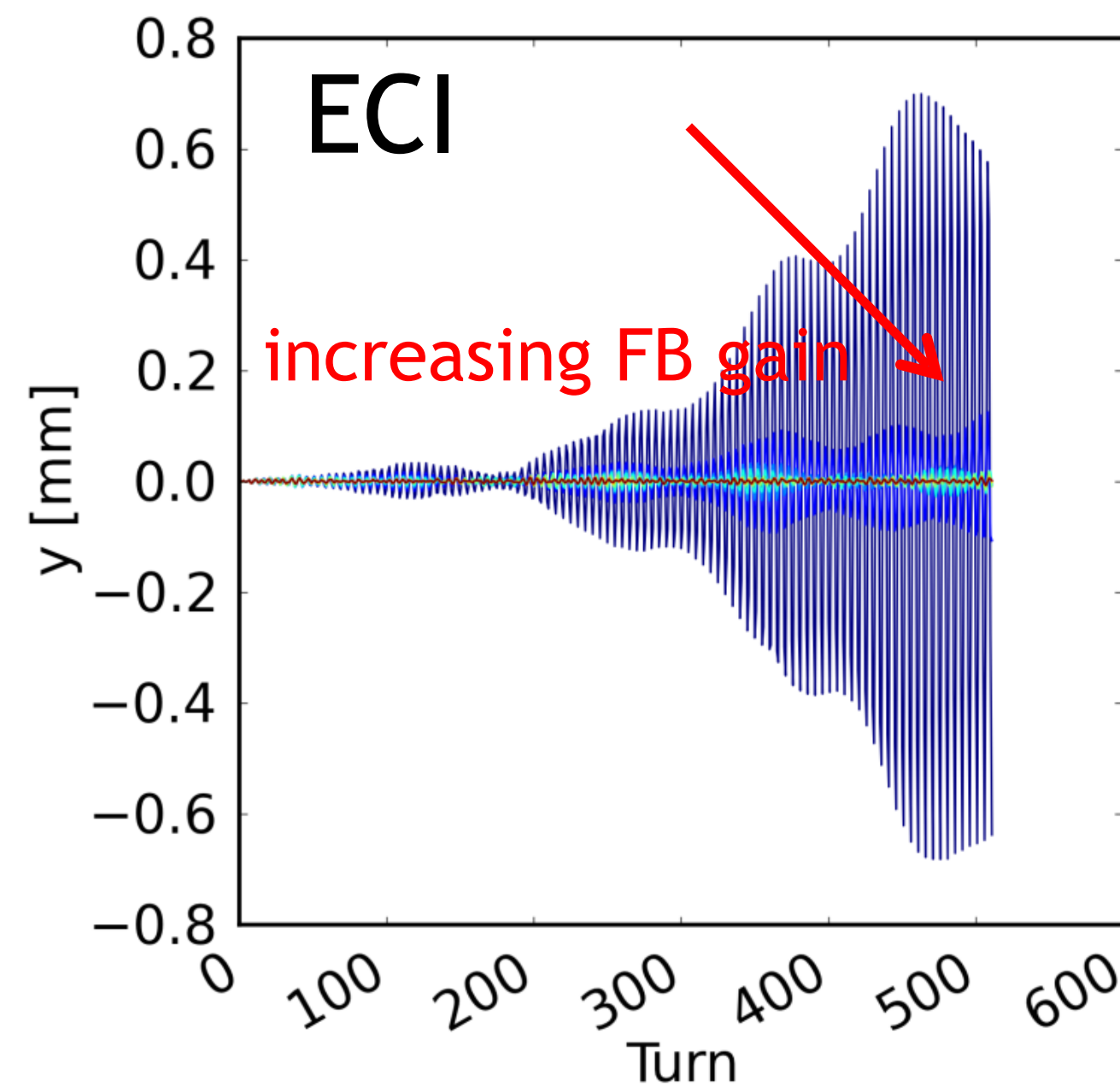

# Wideband feedback system components

- Complete processing channel from pickups through kicker, running a digital **programmable system up to 4 GS/s** is installed and used at 3.2 Gs/s with 16 samples over the 5 ns bucket
- SLAC built prototype includes **multi-bunch processing** of up to 64 bunches
- Kickers:
  - 2 strip-line kickers
  - 2 x 2 power amplifiers with 250 W, frequency range: 5 - 1000 MHz
  - adding a slotline kicker in 2018 → 1.2 GHz

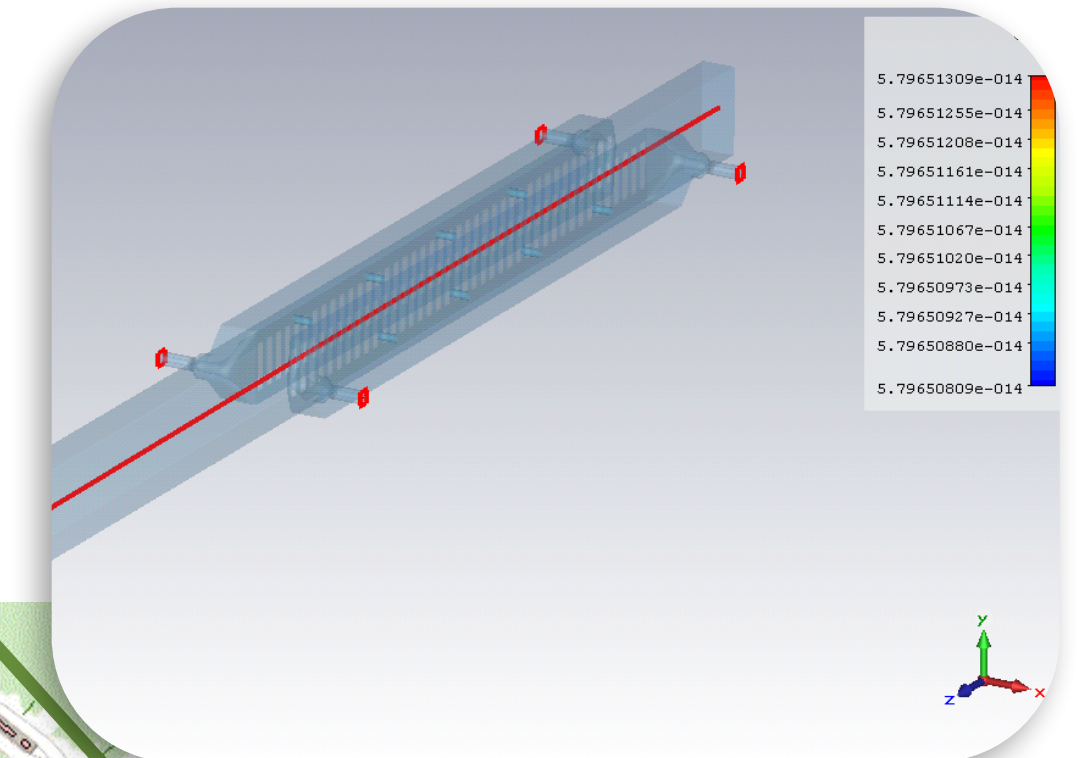
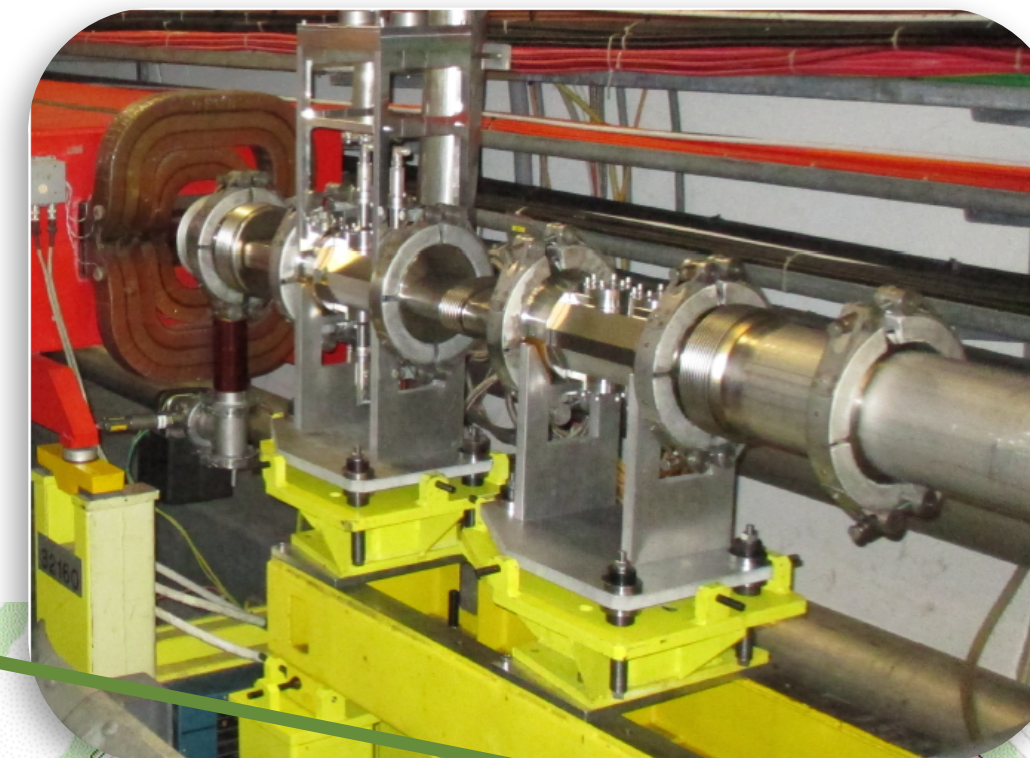
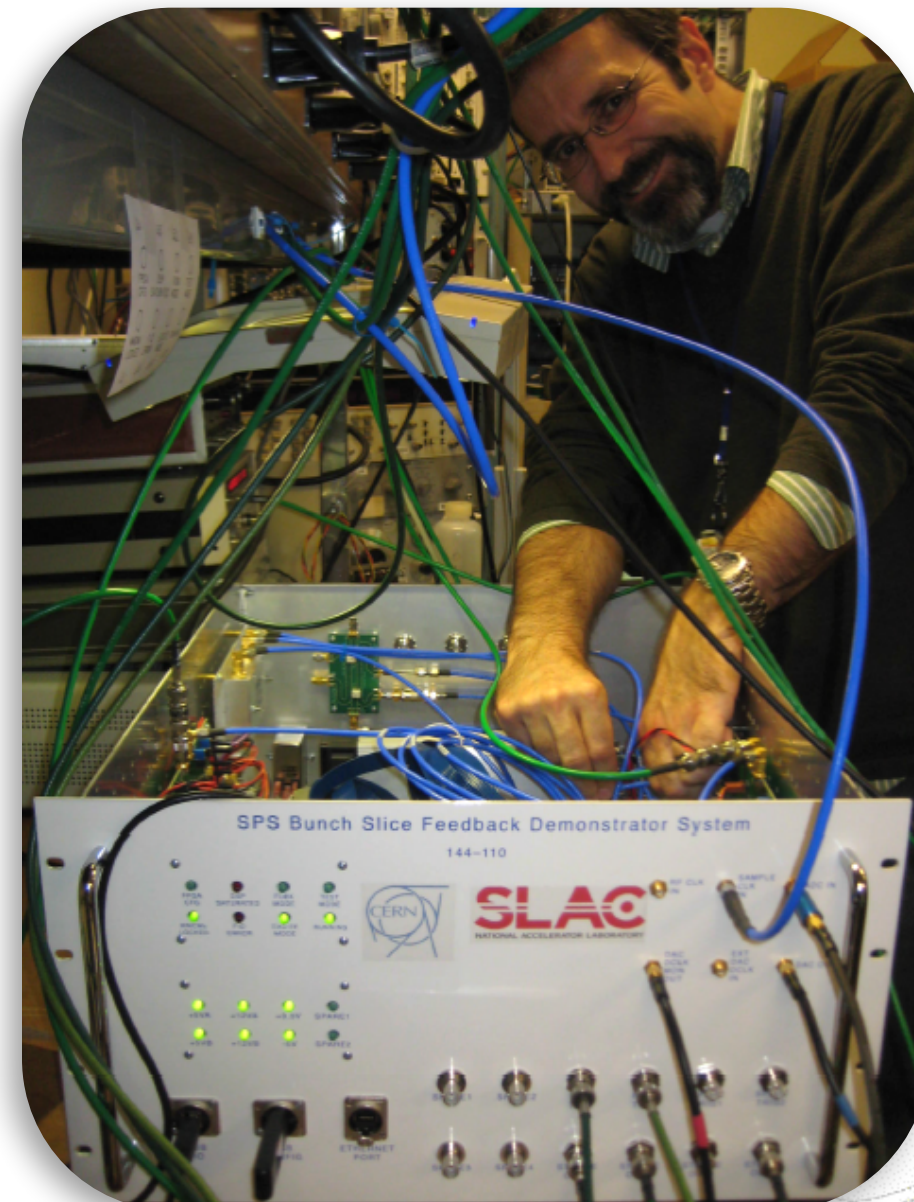
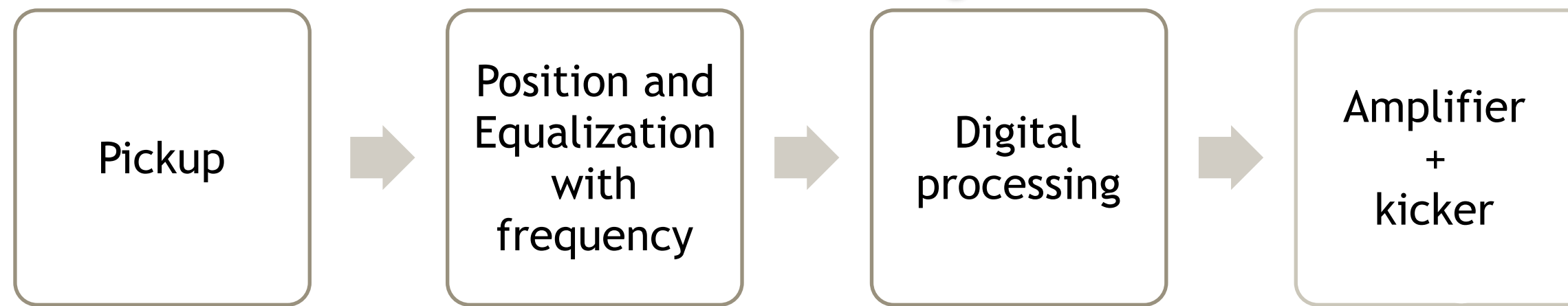

see poster for more information on prototype performance and possible future evolution

J. Fox et al.; WEPAL079

J. Dusatko, J. Fox; WEPAF073

W. Hofle, TUZGBD4

# Comparison of kickers

	$N_{\text{mod}}$	$N_{\text{amp}}$	$P_{\text{amp}}$ (W)	$P_{\text{tot}}$ (W)	$V_{\perp}$ (kV)				
					100 MHz	250 MHz	500 MHz	750 MHz	1000 MHz
Striplines	4	8	500	4000	7.6	7.3	6.3	4.9	3.2
Striplines	44	88	100	8800	37.3	35.9	31.1	23.9	15.5
Slotline	1	2	500	1000	3.2	3.3	3.6	4.2	4.6
Slotline	1	2	2000	4000	6.4	6.6	7.2	8.4	9.3
Slotline	6	12	300	3600	14.8	15.3	16.7	19.4	21.5

$$\Delta x' \propto \frac{eV_{\perp}}{E}$$

- Stripline - 10 cm
- Slotline - 1 m

J. Cesaratto et al.:  
*SPS Wideband Transverse Feedback Kicker: Design Report,*  
 CERN-ACC-NOTE-2013-0047  
 M. Wendt et al.: IPAC'17, TUPIK053

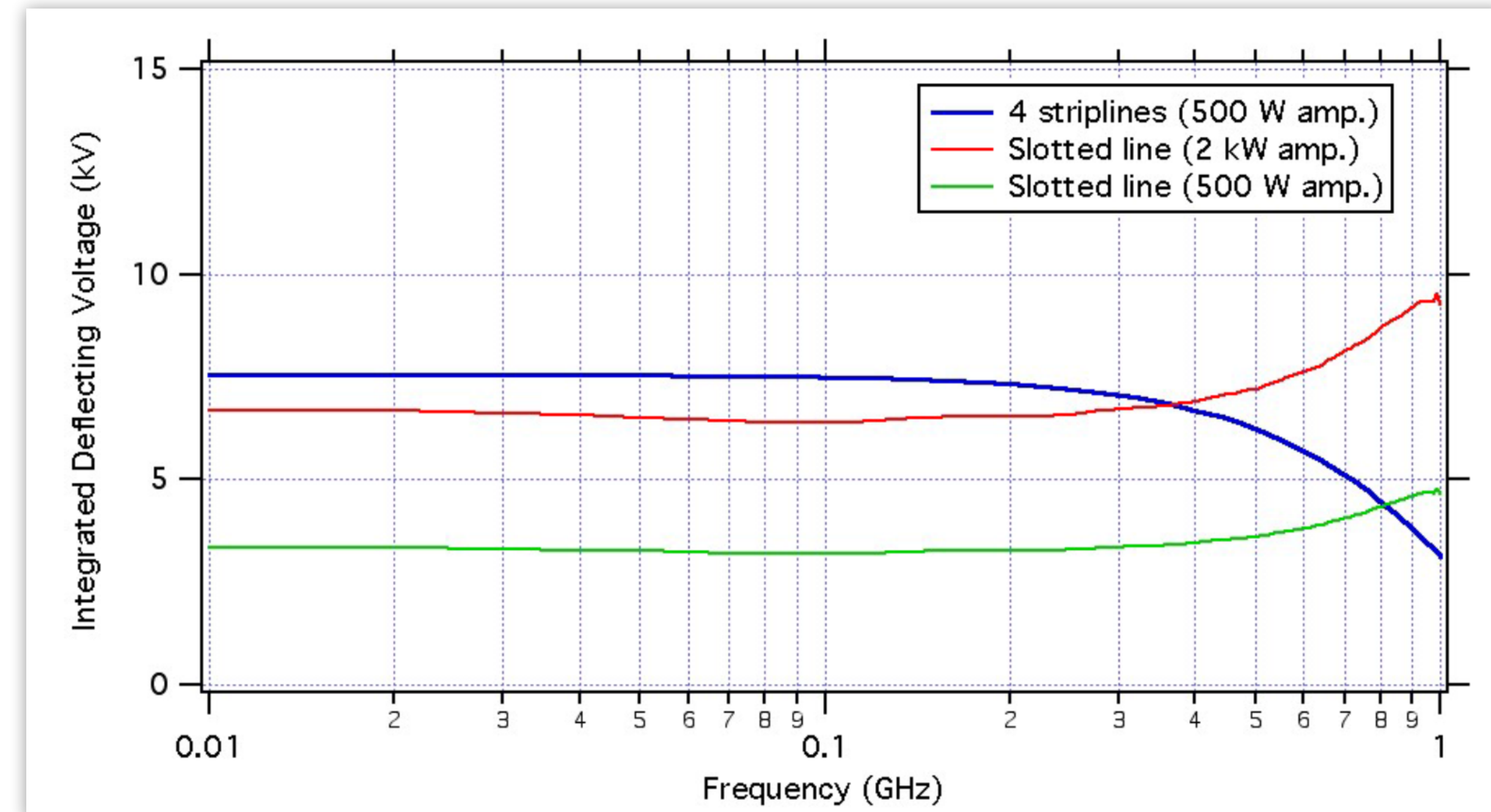
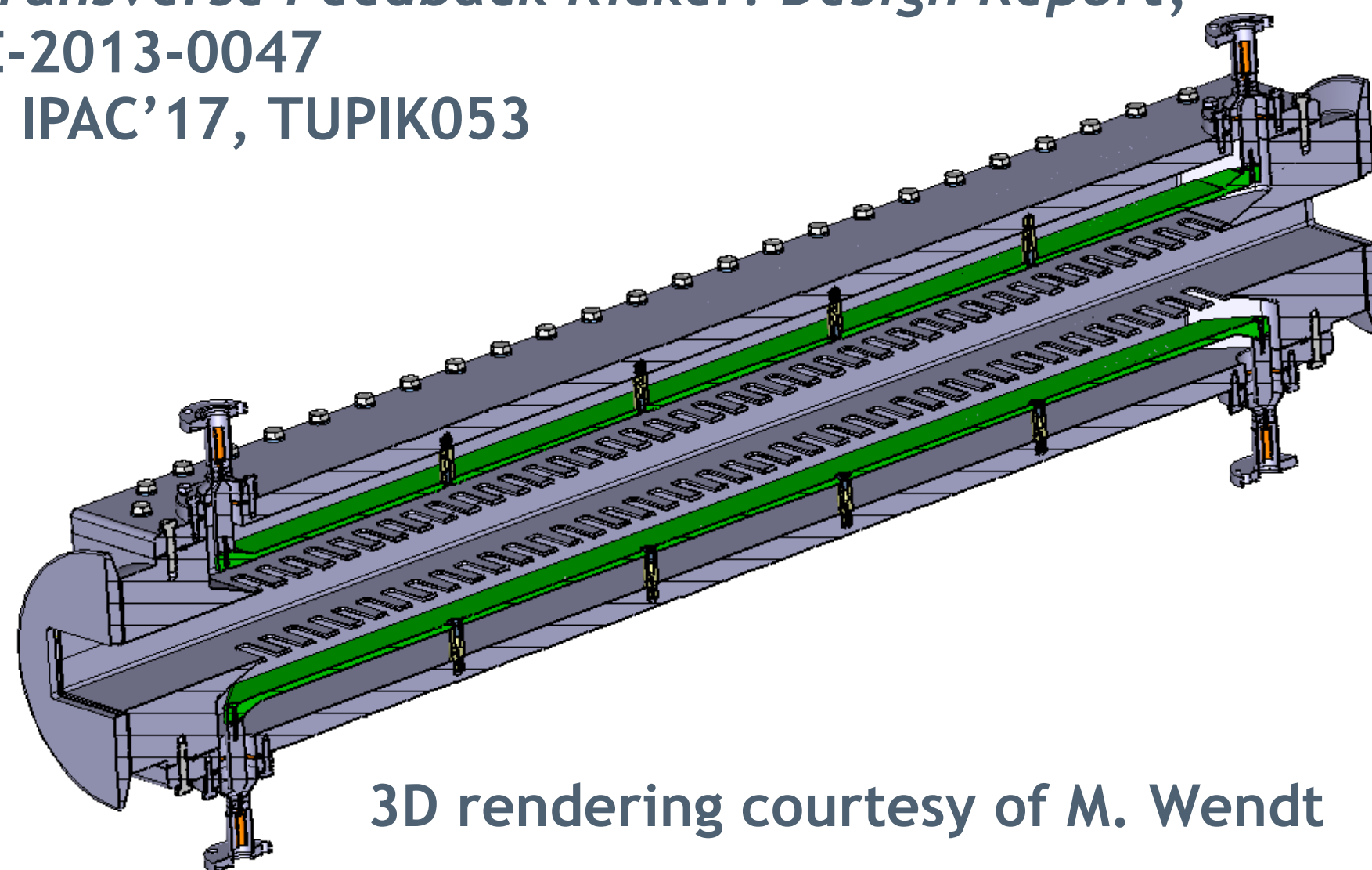

# Installed Kickers in SPS Tunnel

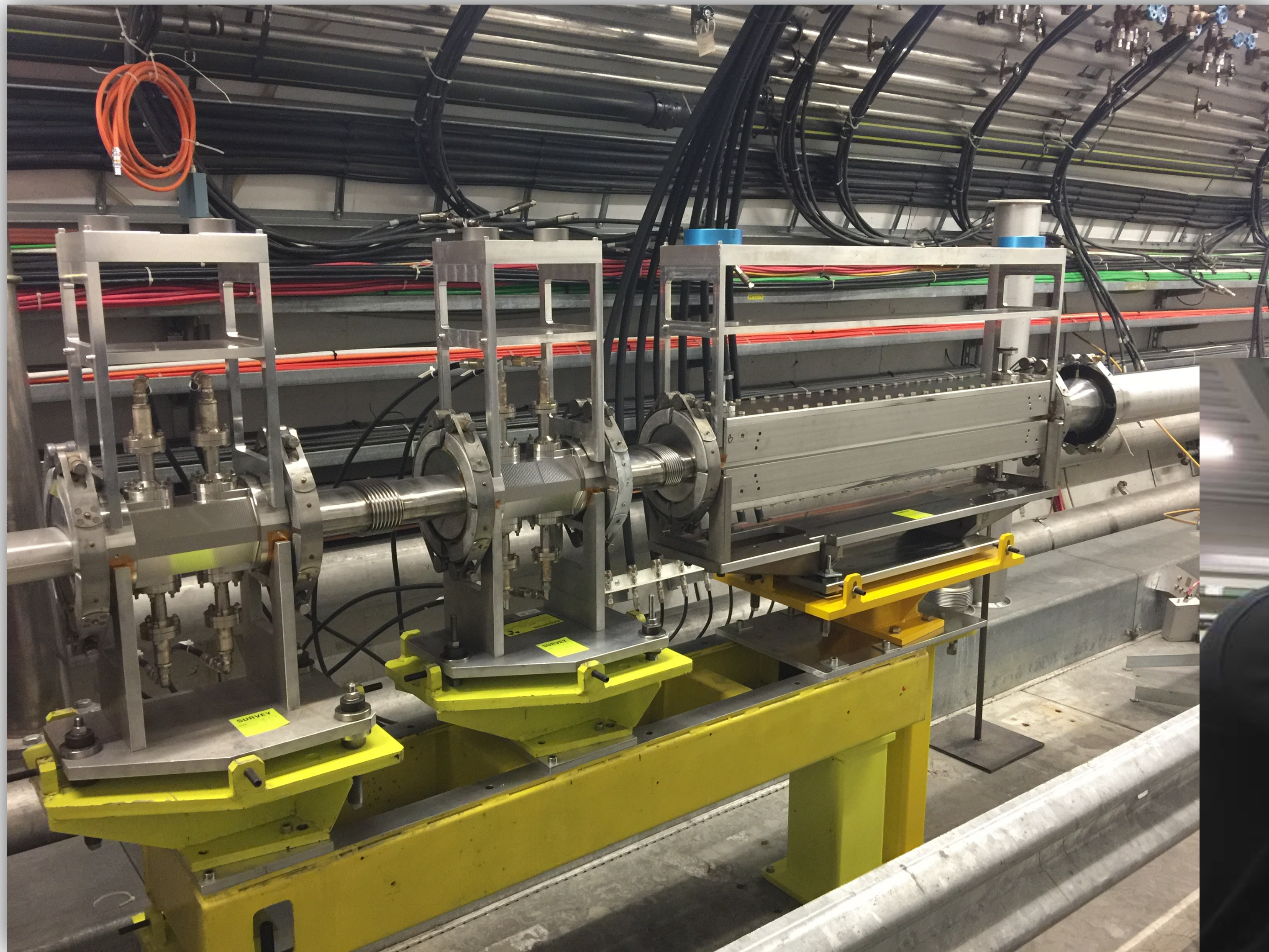

# Results for Multi-bunch Beams: Q20 optics

- conventional damper needed to control the coupled bunch instabilities
- single bunch instabilities not well under control by coupled bunch feedback
- appear at low chromaticity and in presence of electron cloud

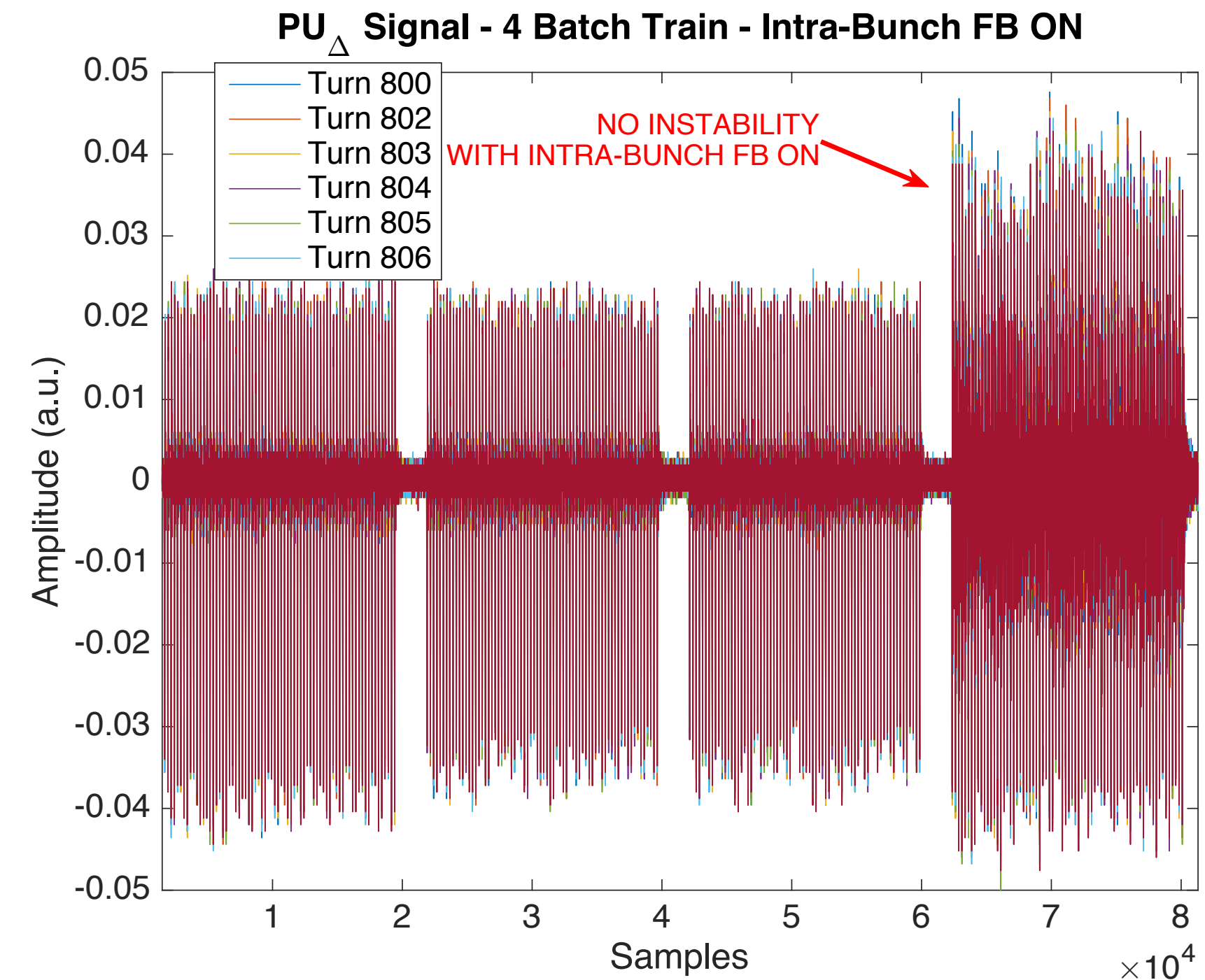
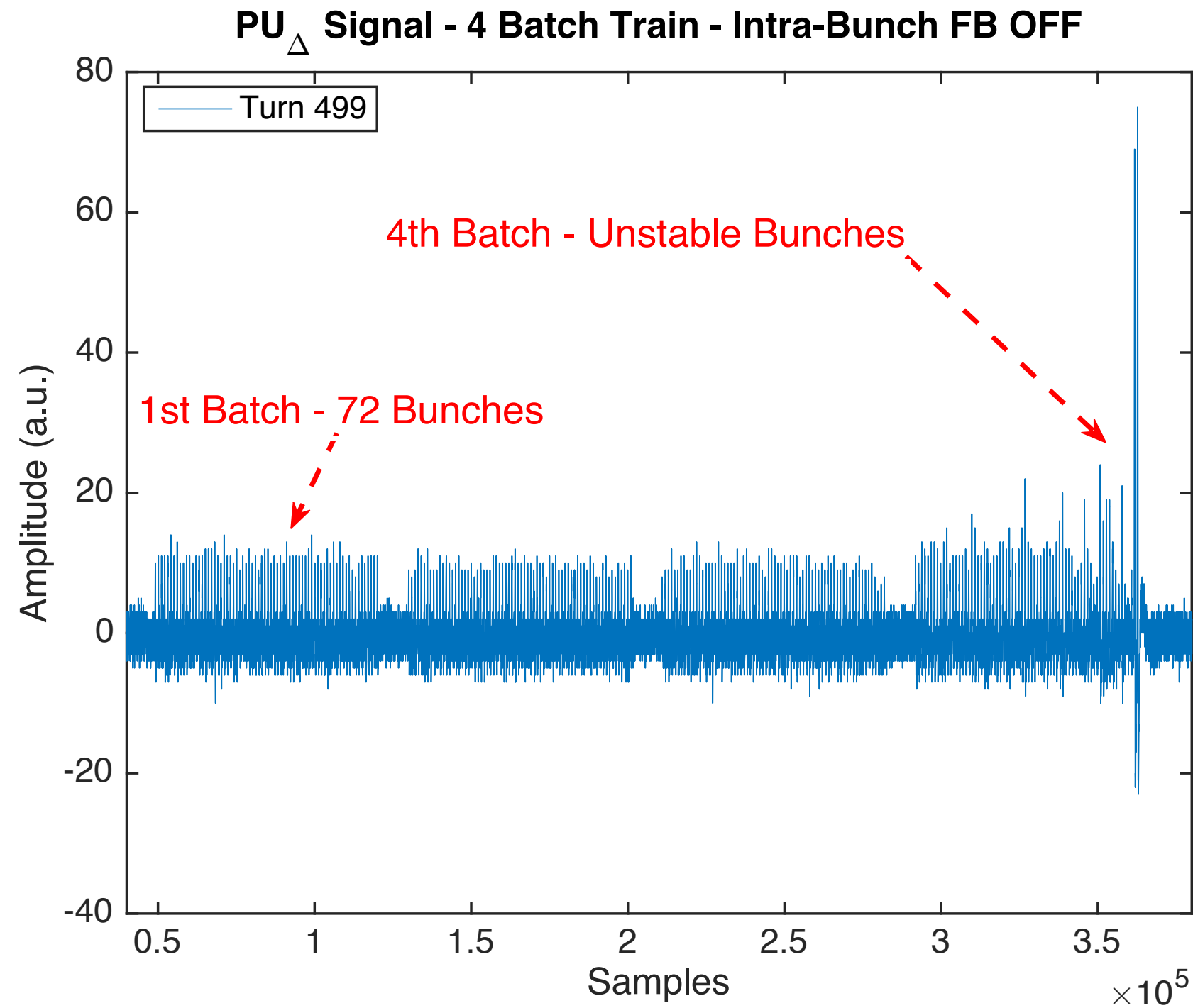

4x72 bunches

# Single Bunch results in Q26 Optics

- Operating at injection with the conventional and the Wideband feedback in conjunction stabilises the beam in the “slow” TMCI regime in Q26 optics

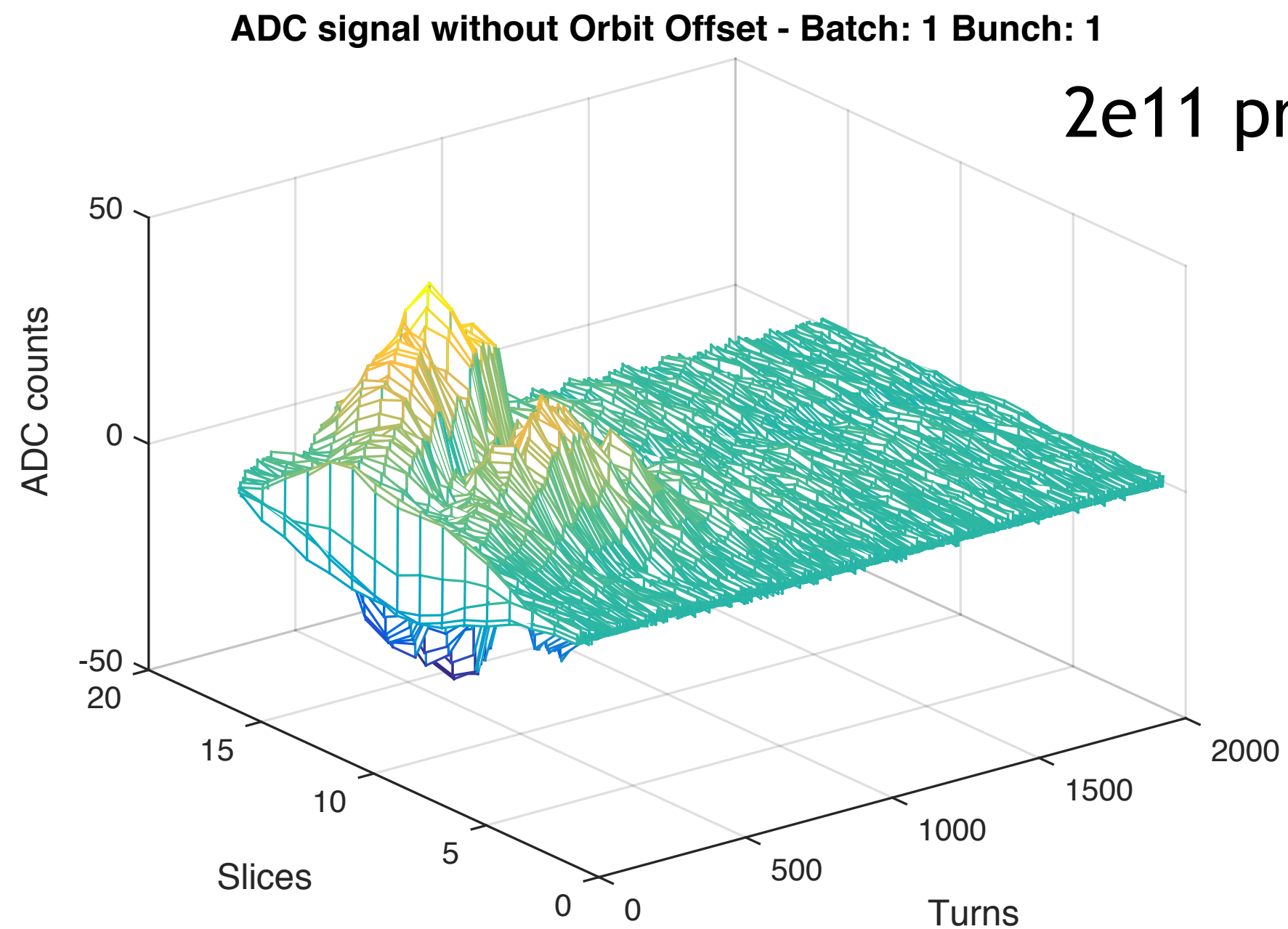

Wideband feedback off  
 —> intra-bunch oscillation, beam lost

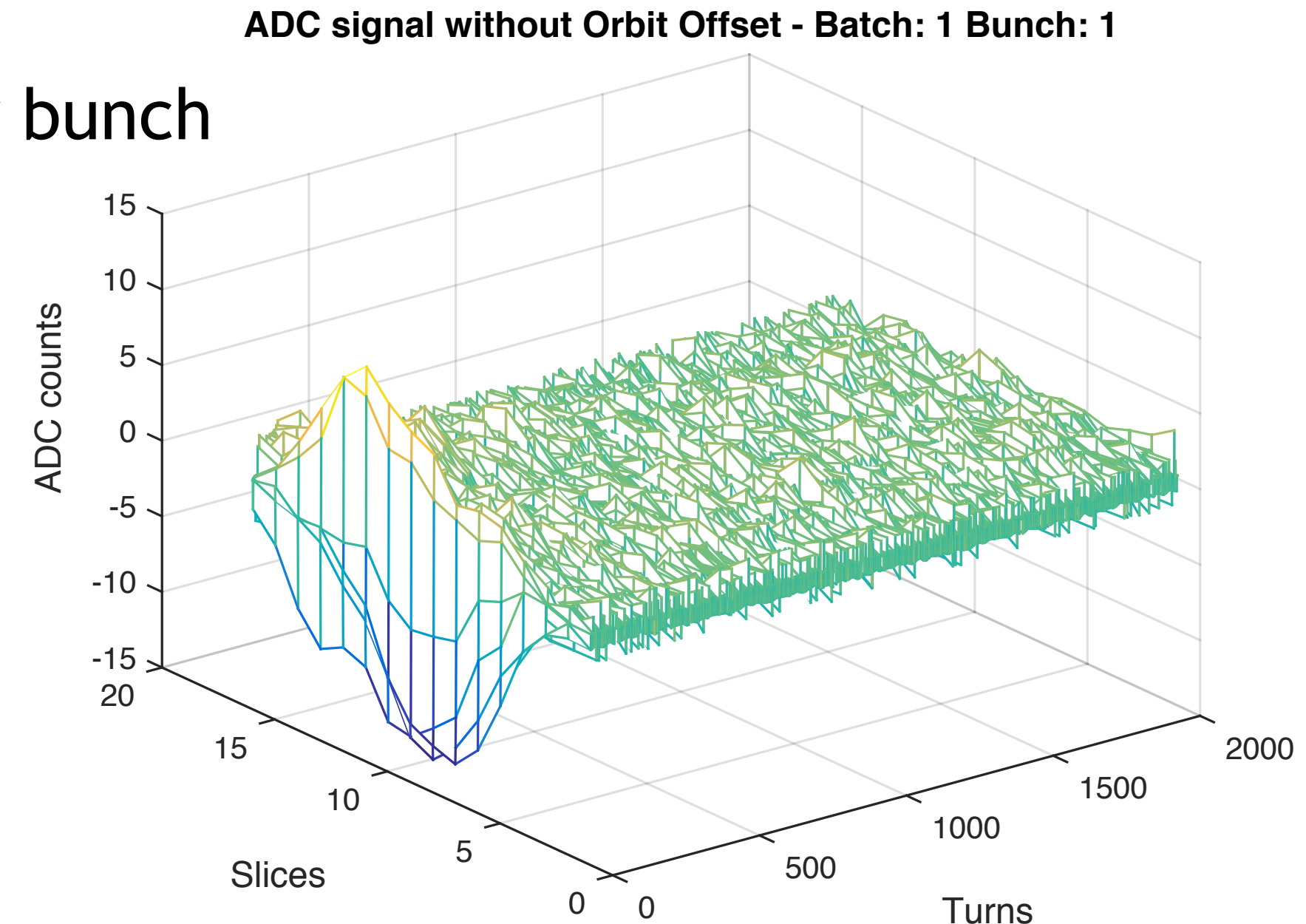

Wideband feedback on  
 —> intra-bunch oscillation damped

# Single Bunch Results in Q26 Optics

- $2e11$  protons per bunch with Wideband feedback and conventional damper on

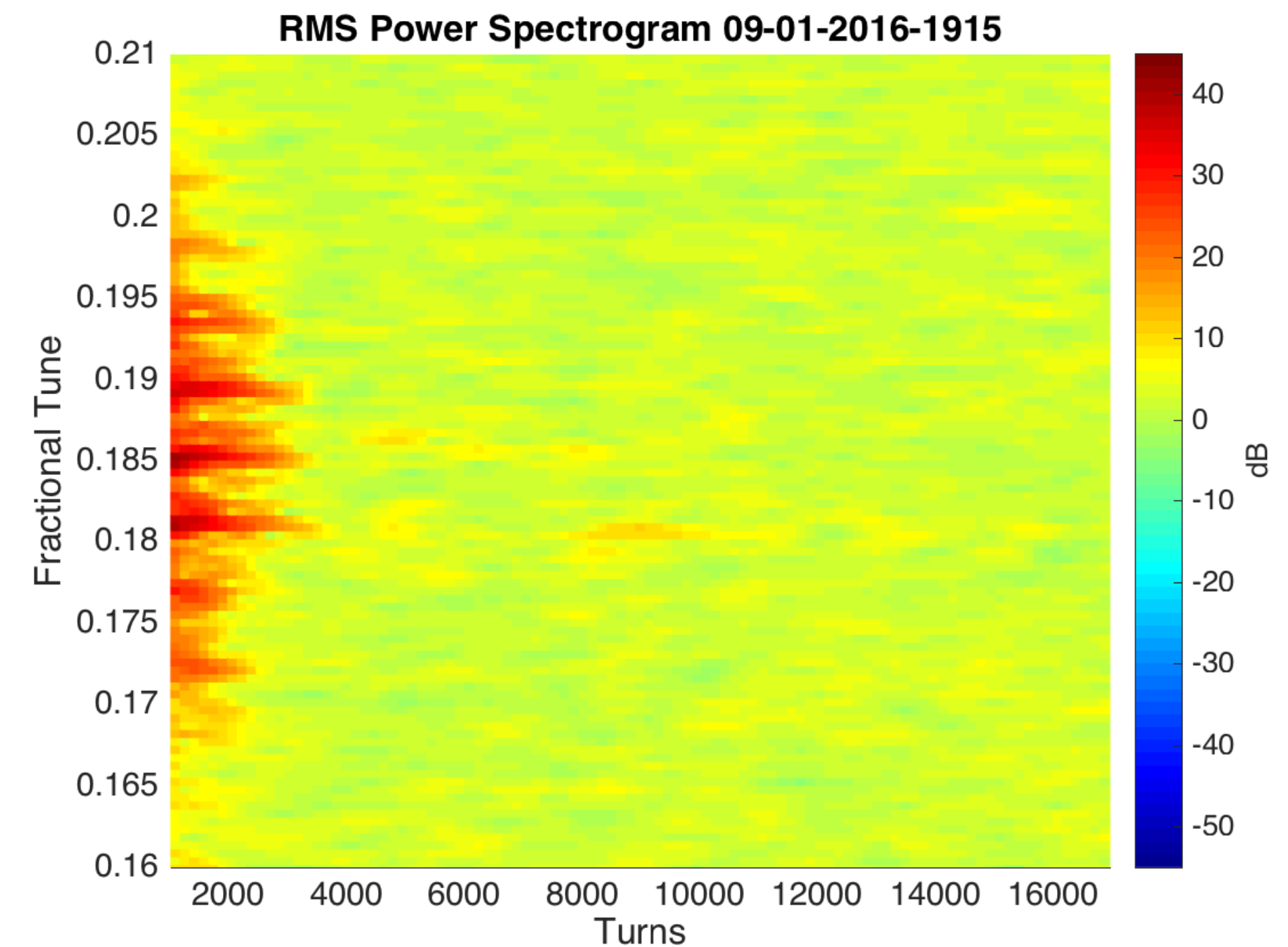
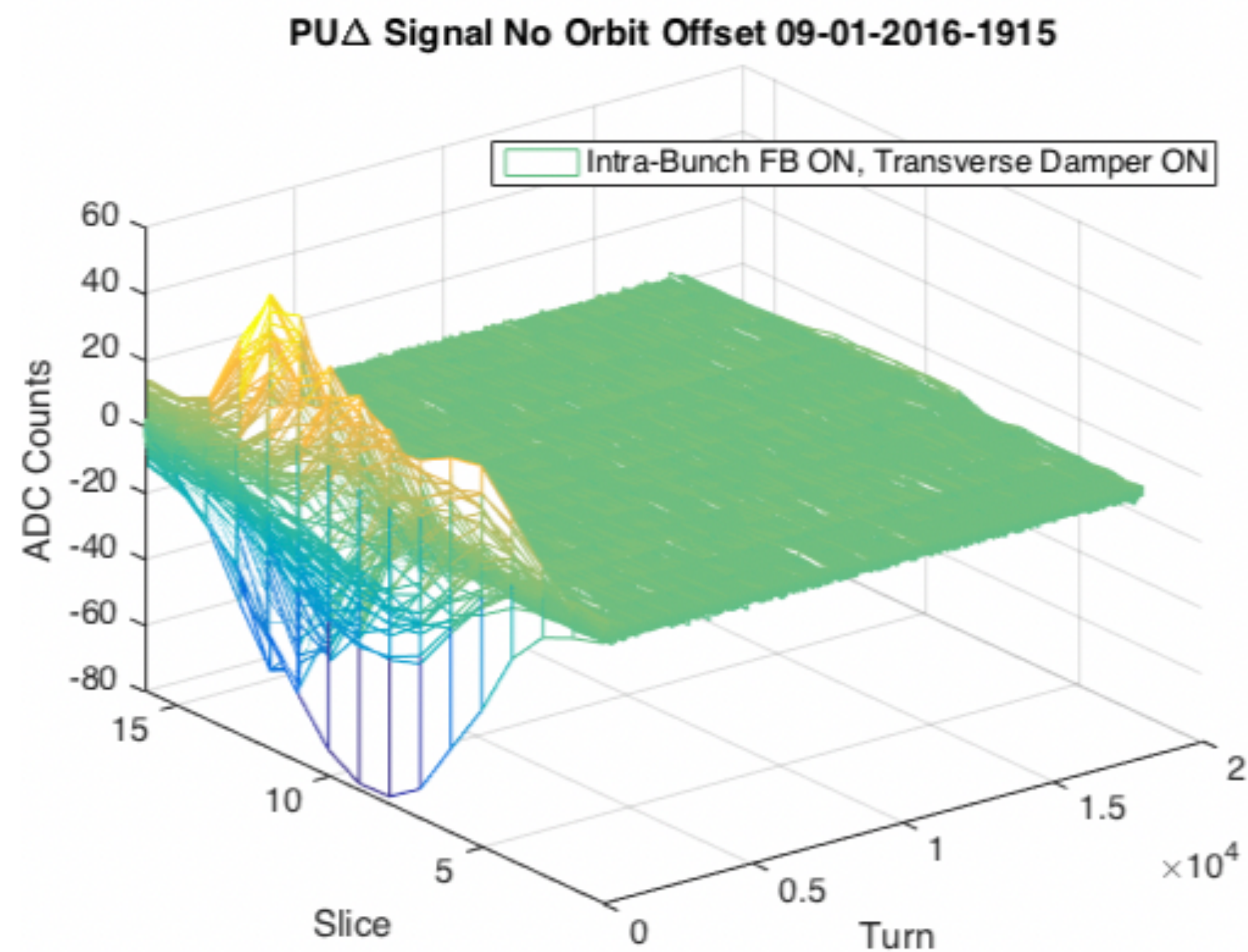



# Reminder – SPS TMCI thresholds

- The SPS standard optics “Q26” has been with integer tune of 26 and gamma transition of 22.8 until 2012 for LHC beams
  - TMCI threshold scales with slippage factor, injection is at gamma of 27.7
  - Threshold is at  $1.5e11$  protons per bunch
- 2013 the “Q20” optics became available operationally; gamma transition of 18
  - tripples instability threshold → future intensities needed are not limited by transverse instabilities
  - more RF voltage and power needed for Q20 than for Q26
- Exploration of a new optics with integer tune of 22 “Q22” and intermediate gamma transition of 20 has started
  - TMCI threshold at  $2.5e11$  per bunch at 0.32 eVs

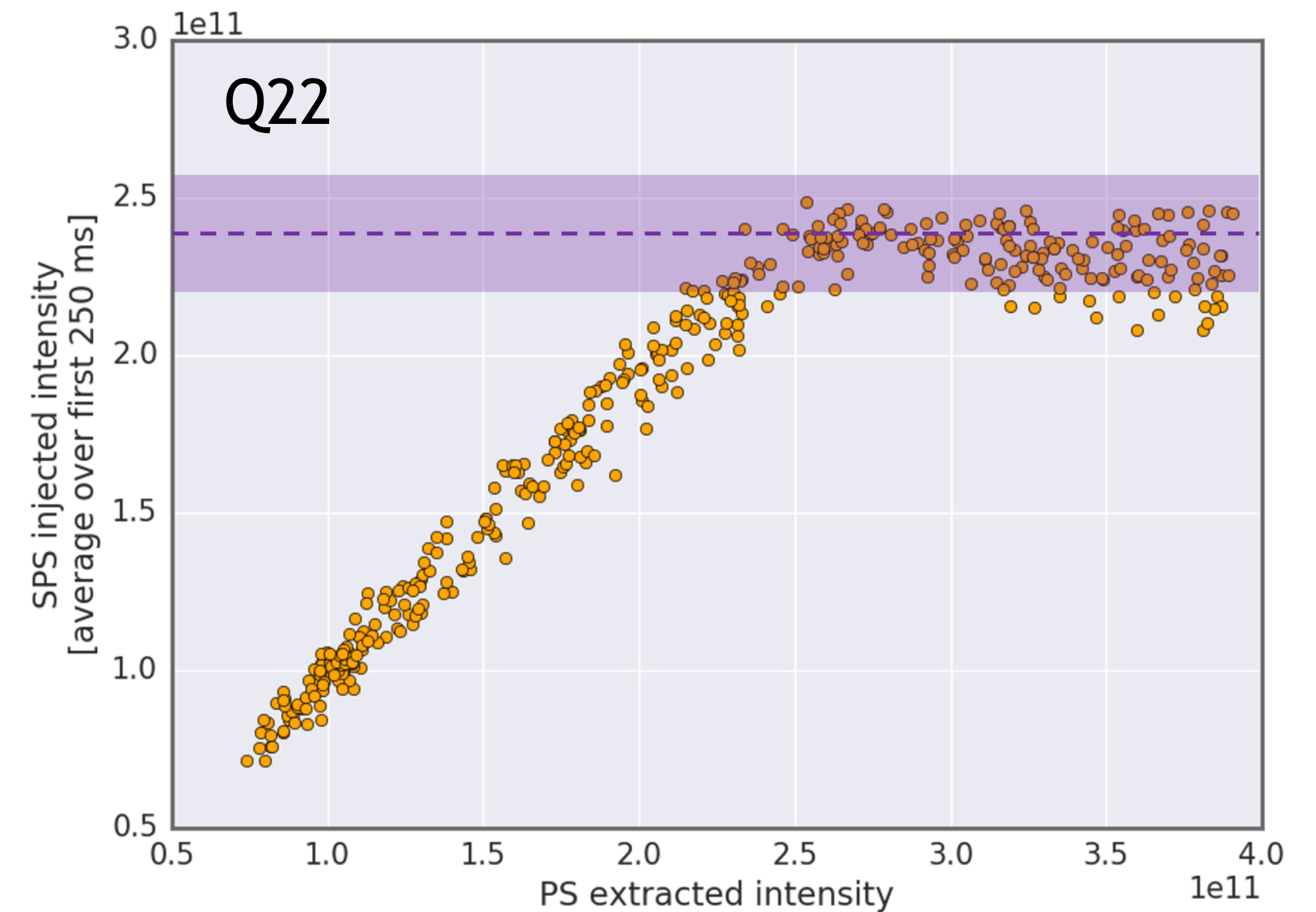

see poster M. Carla et al.  
TUPAF022

# Q22: Intensity scan 2018

- Due to limitations imposed by the ions cycle the injected intensity had to be reduced → the RF voltage was reduced adequately to obtain TMCI at a lower intensity.
- First test... looking at the BCT, **a constant signal** is observed all along the cycle.
- To be noted that we are **injecting high intensity beams** ( $\sim 2.5e11$  ppb) → TMCI induced losses occur before the first BCT sampling point
- A look into the HEADTAIL monitor **just after injection reveals the TMCI**.

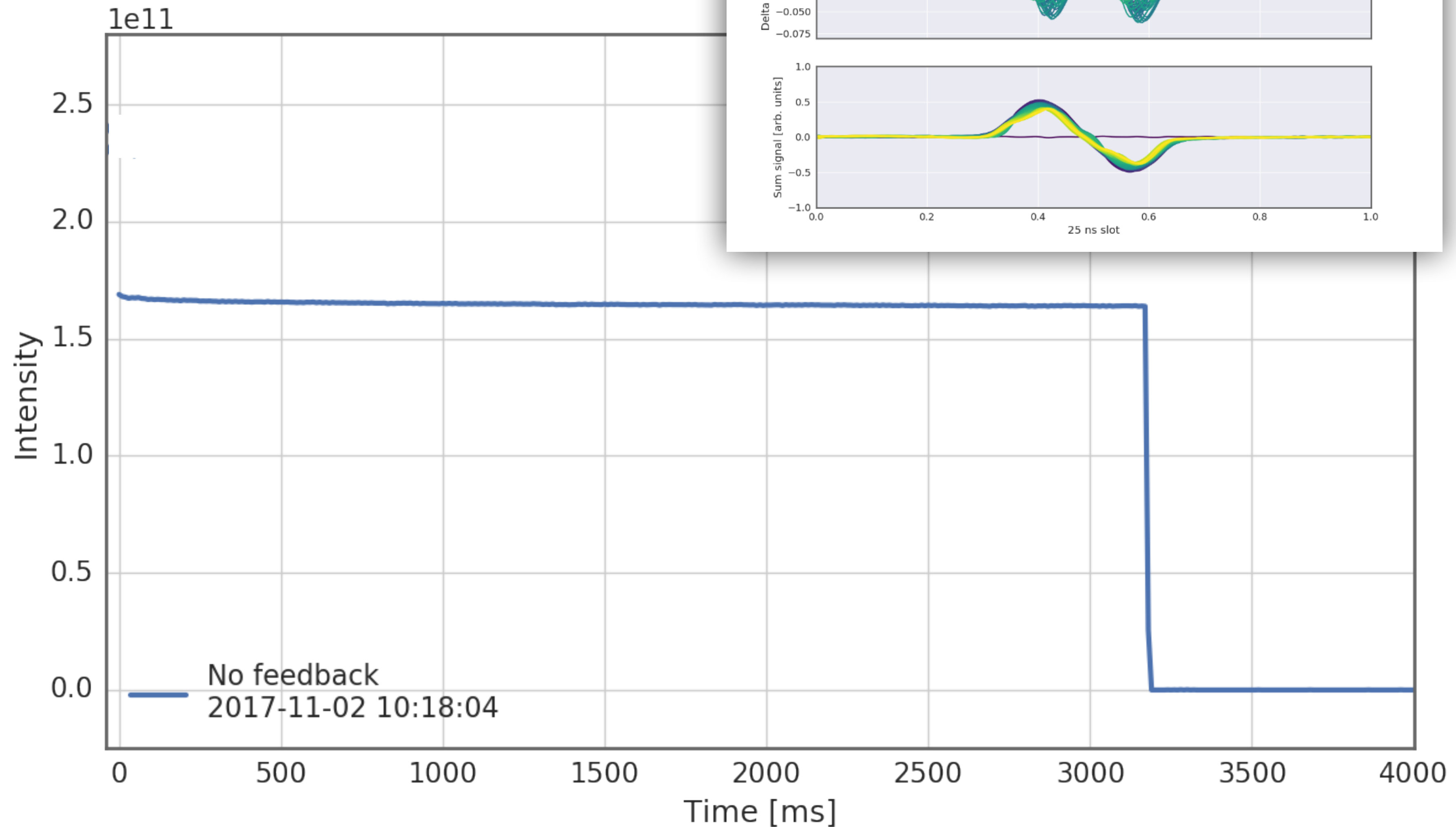

# Q22: Intensity Scan 2018

- The **standard transverse damper** was set up and put into operation in an attempt to mitigate the instability.
- The fast growth was reduced but **could not be stopped**. The losses are ultimately comparable to running without the transverse damper.
- This is expected **due to the bandwidth limitations** of the transverse damper... the high frequency content of the instability remains unaffected.

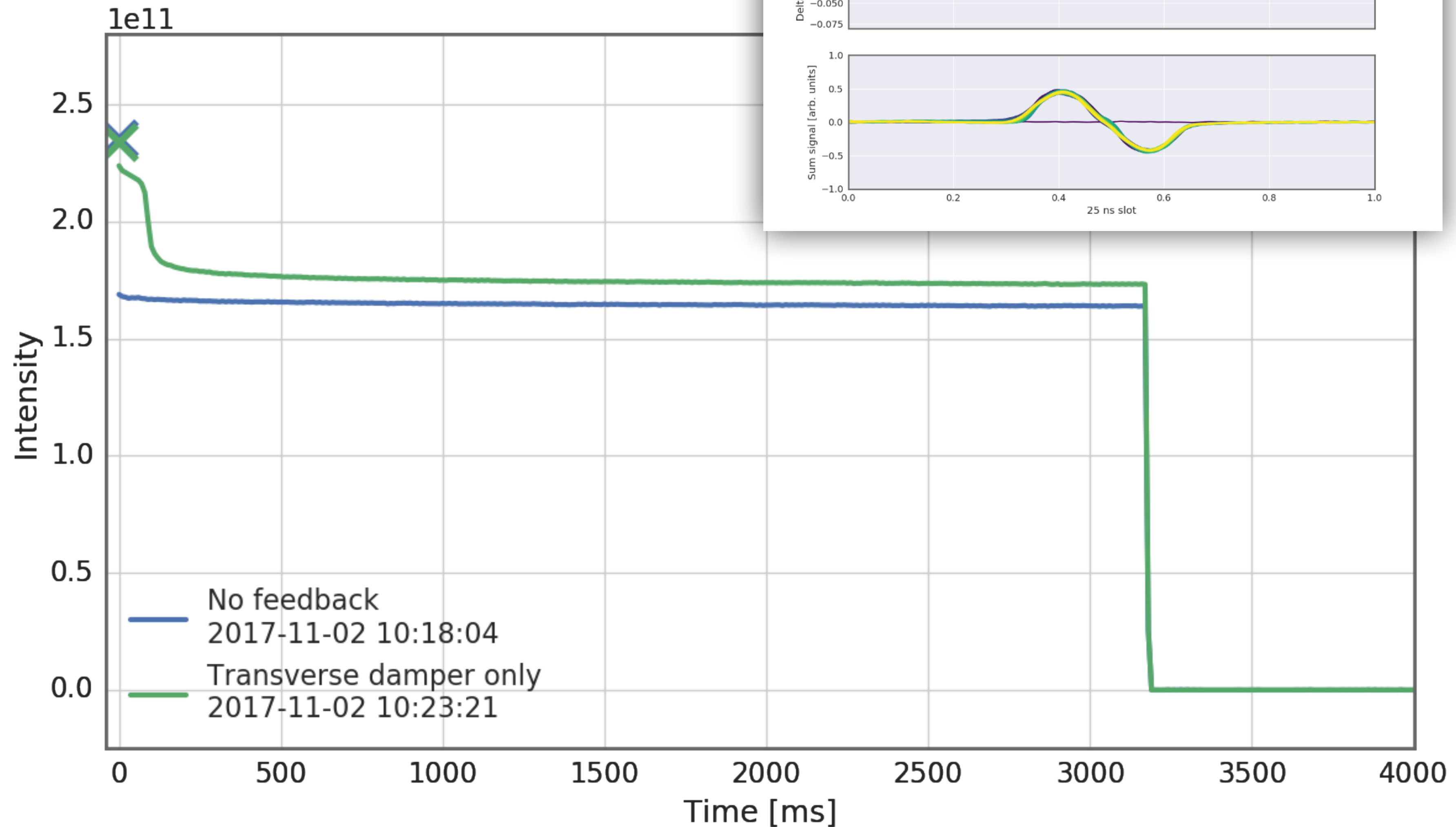

# Intensity Scan 2018

- Finally, the **wideband feedback system** was time aligned, configured and activated by closing the loop over the observed instability.
- The **transverse damper was kept active** to control the large amplitude low frequency motion to prevent saturation of the ADCs which would otherwise render the wideband feedback system ineffective.
- With the **two systems active**, the **losses are significantly reduced** and comparable to what is observed in absence of TMCI.

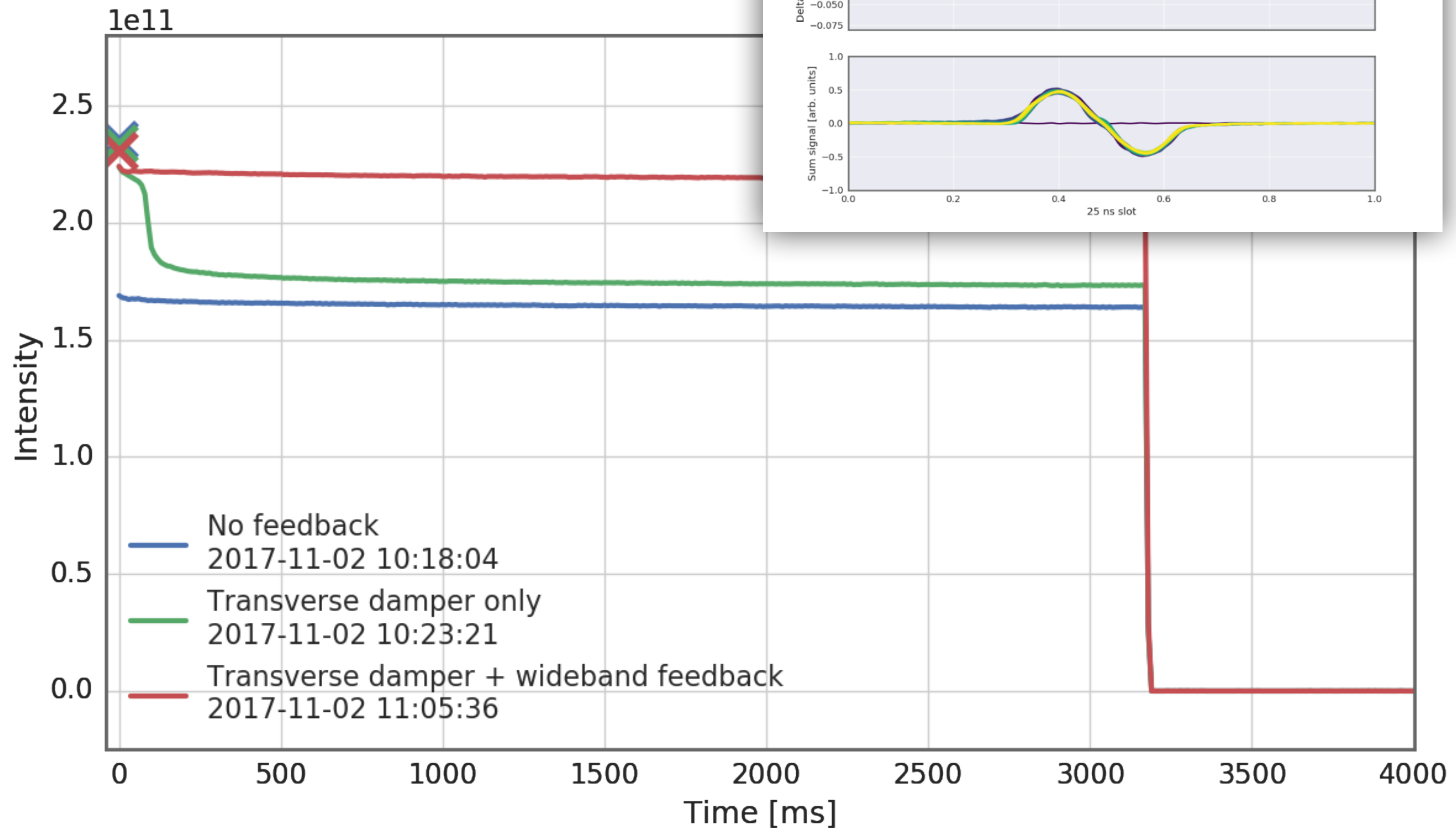

# Q22: Intensity scan 2018

- The wideband feedback loop **was closed and opened several times** over a period of half an hour **to ensure reproducibility** of both the TMCI and the stabilization of the latter.

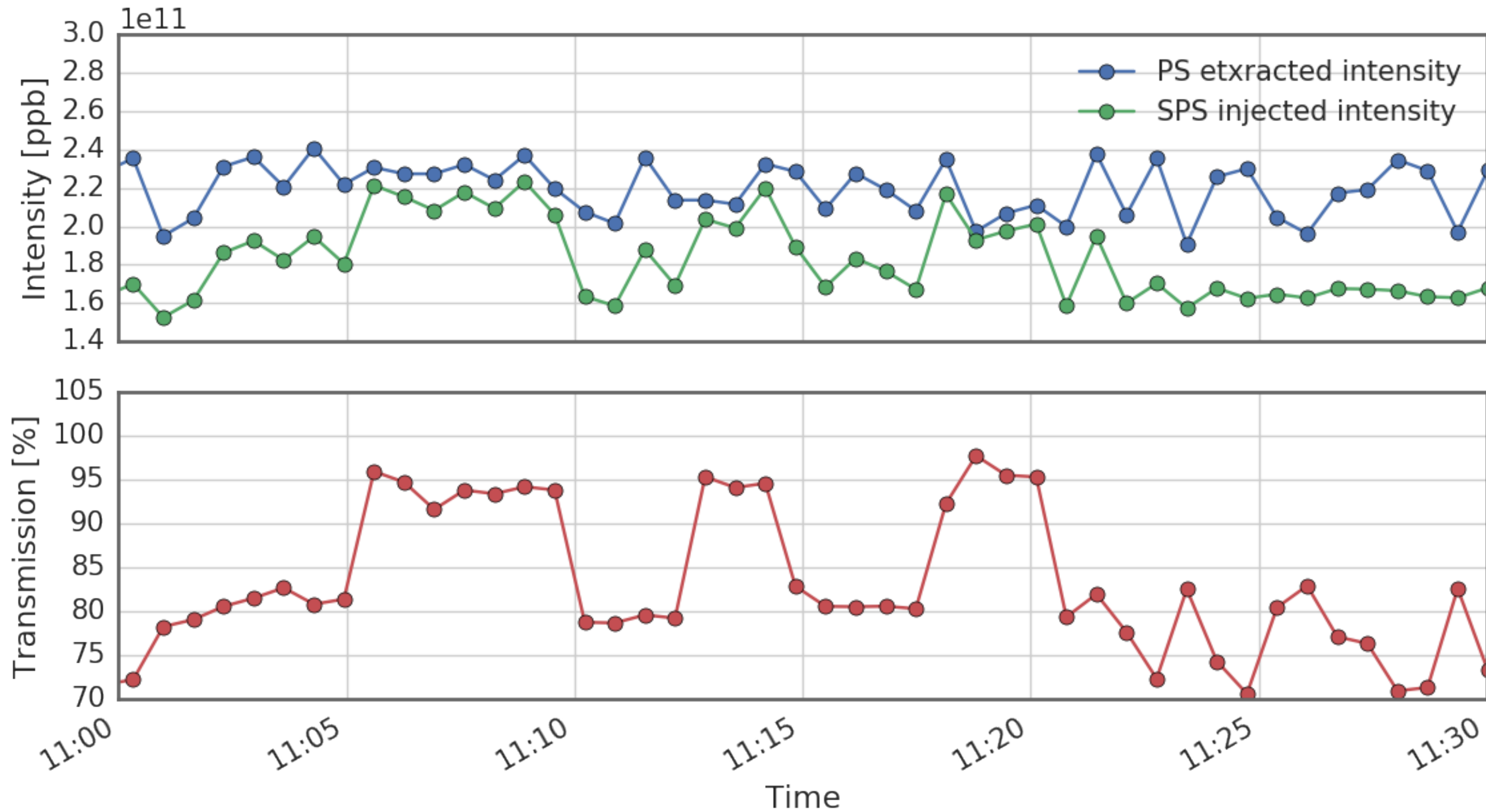

# Q22: Intensity Scan

- The wideband feedback loop **was closed and opened several times** over a period of half an hour **to ensure reproducibility** of both the TMCI and the stabilization of the latter.
- There is a **clear correlation** between transmission and open/closed loop configuration.

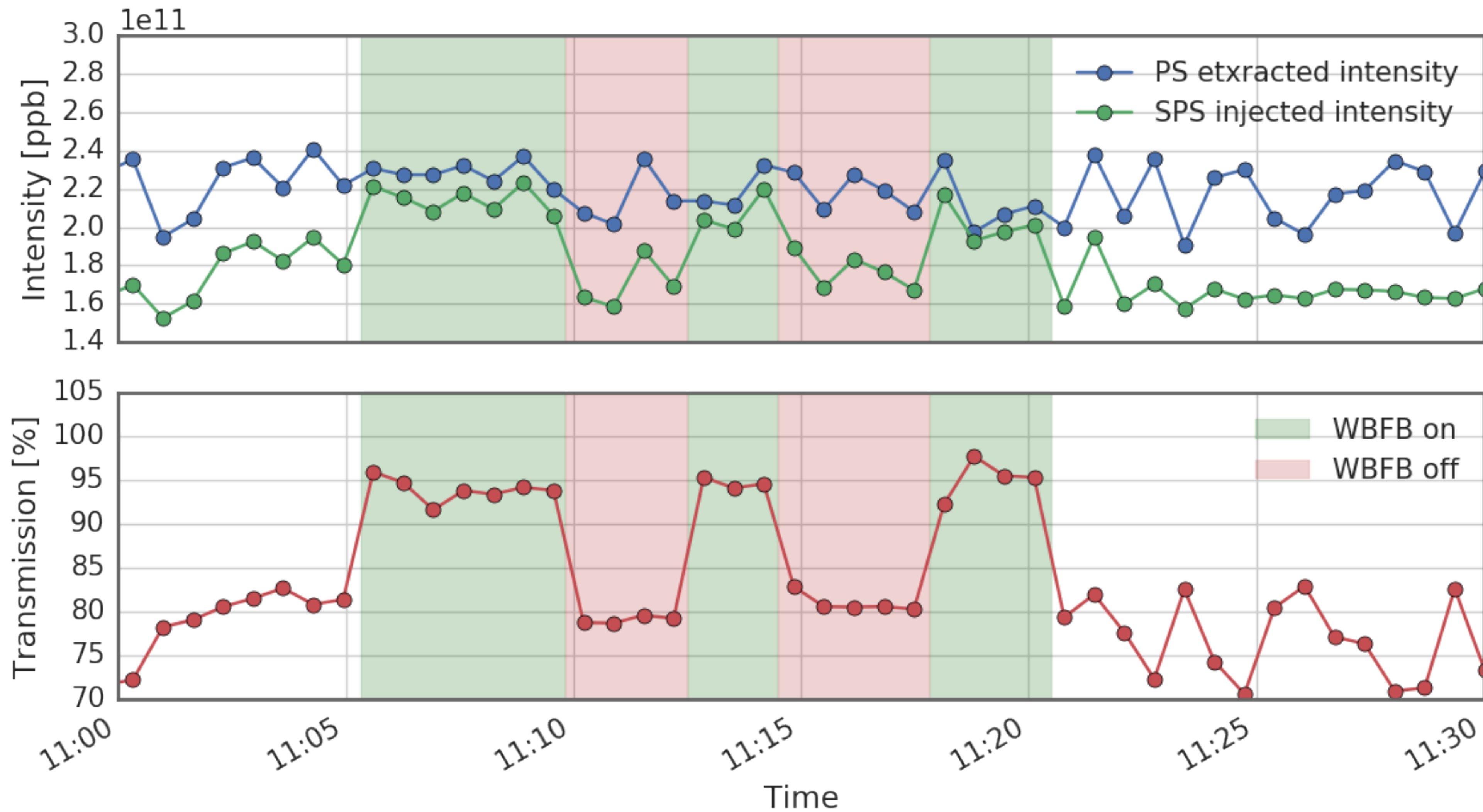

# Intensity scan

- One can now make a comparison of the intensity reach (average over first 250 ms) in the different configurations:

- **No feedback**

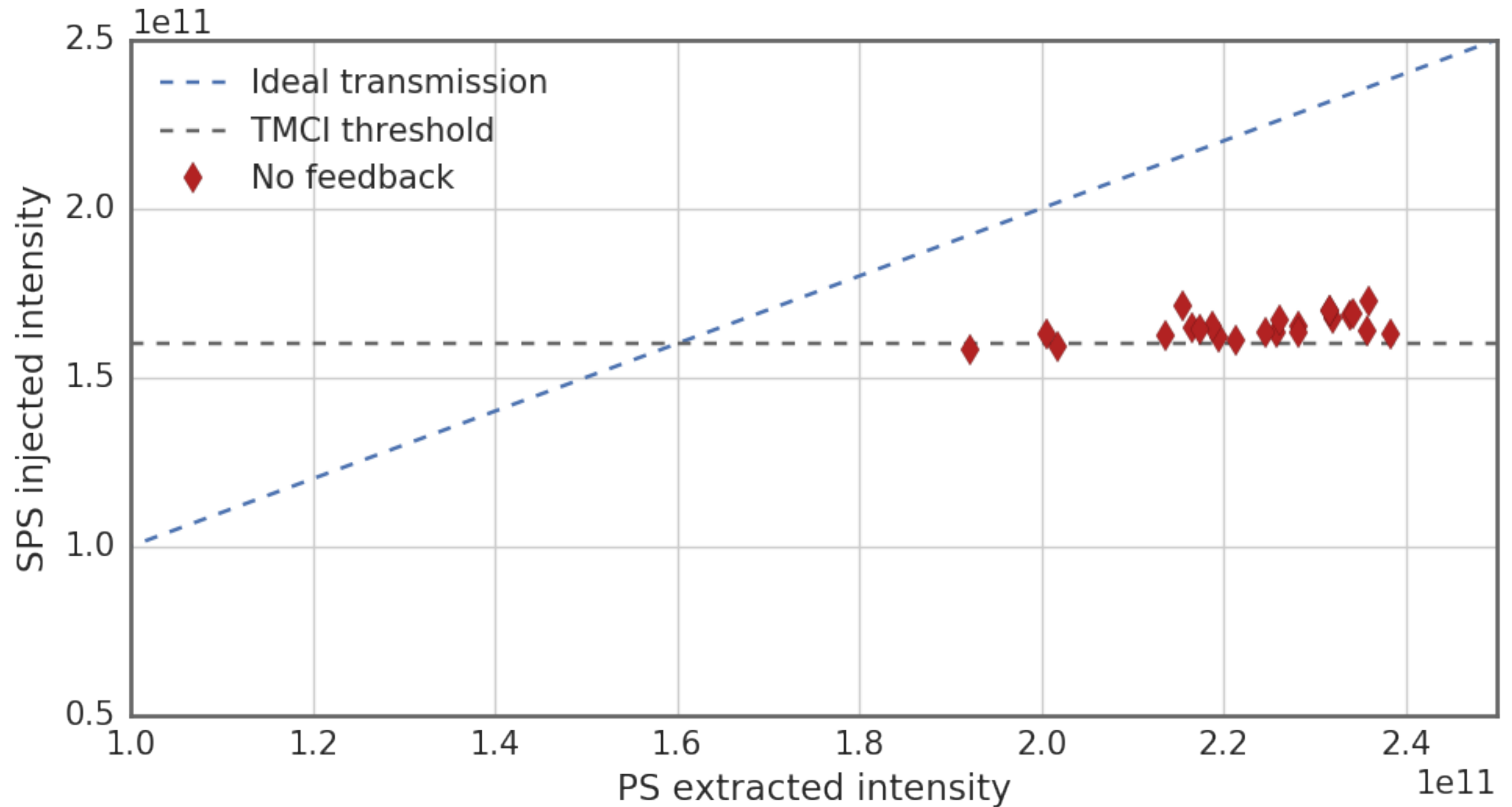

# Intensity scan

- One can now make a comparison of the intensity reach (average over first 250 ms) in the different configurations:

- **No feedback**
- **Transverse damper**

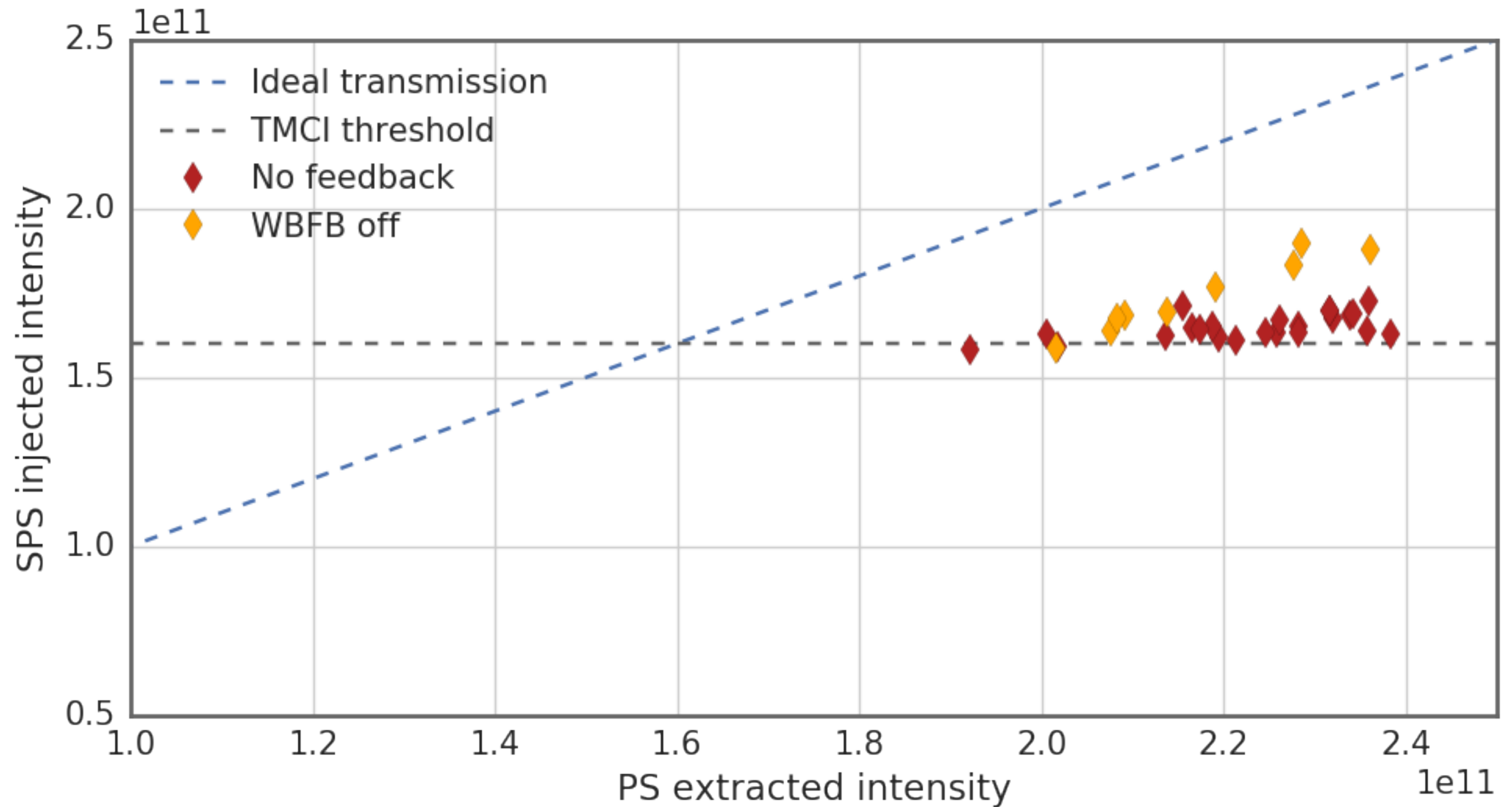

# Intensity scan

- One can now make a comparison of the intensity reach (average over first 250 ms) in the different configurations:

- **No feedback**
- **Transverse damper**
- **Transverse damper + wideband feedback**

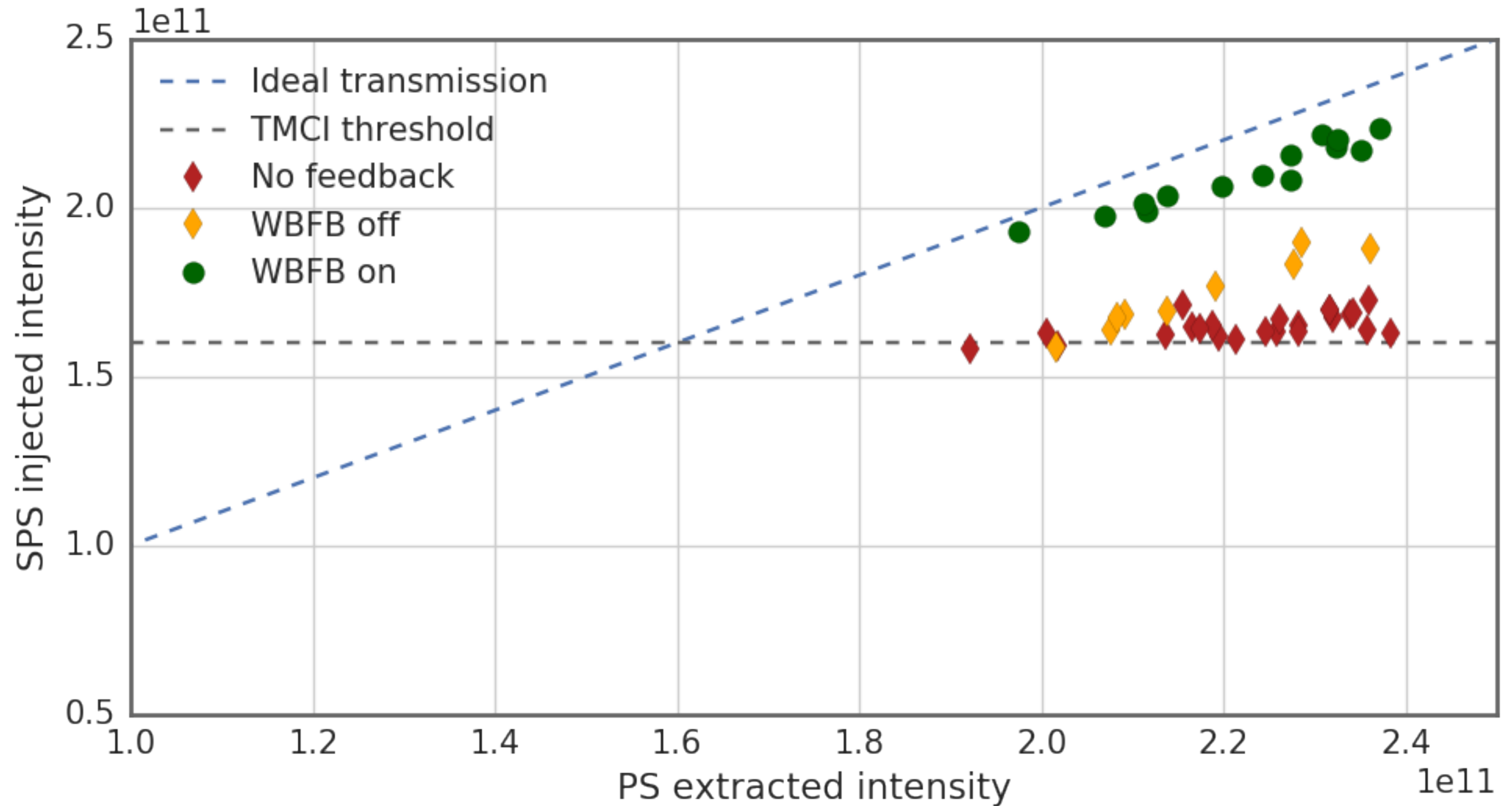



# Conclusions and outlook

- Prototype Wideband Transverse Feedback System in SPS for vertical plane deployed
  - Demonstrator as a proof of principle for LHC type beams at injection 26 GeV/c
  - Signal processing operating at 3.2 GS/s, treating up to 64 bunches
- Recent achievements include
  - damping multi-bunch **centroid** (beam instability at low chromaticities)
  - damping of single intra-bunch oscillations in **TMCI regime**
  - demonstrated increase of intensity reach in the SPS Q22 optics
- Next steps
  - Extension of kick strength and frequency reach by commissioning slotline kicker in 2018
  - Machine studies using the nominal beam parameters of the LIU beams



# LHC Injectors Upgrade



# The Transverse mode coupling instability

- SPS TMCI has a long history of studies...
- It can be reasonably well reproduced using a broadband resonator impedance model at around 1.3GHz

H. Bartosik

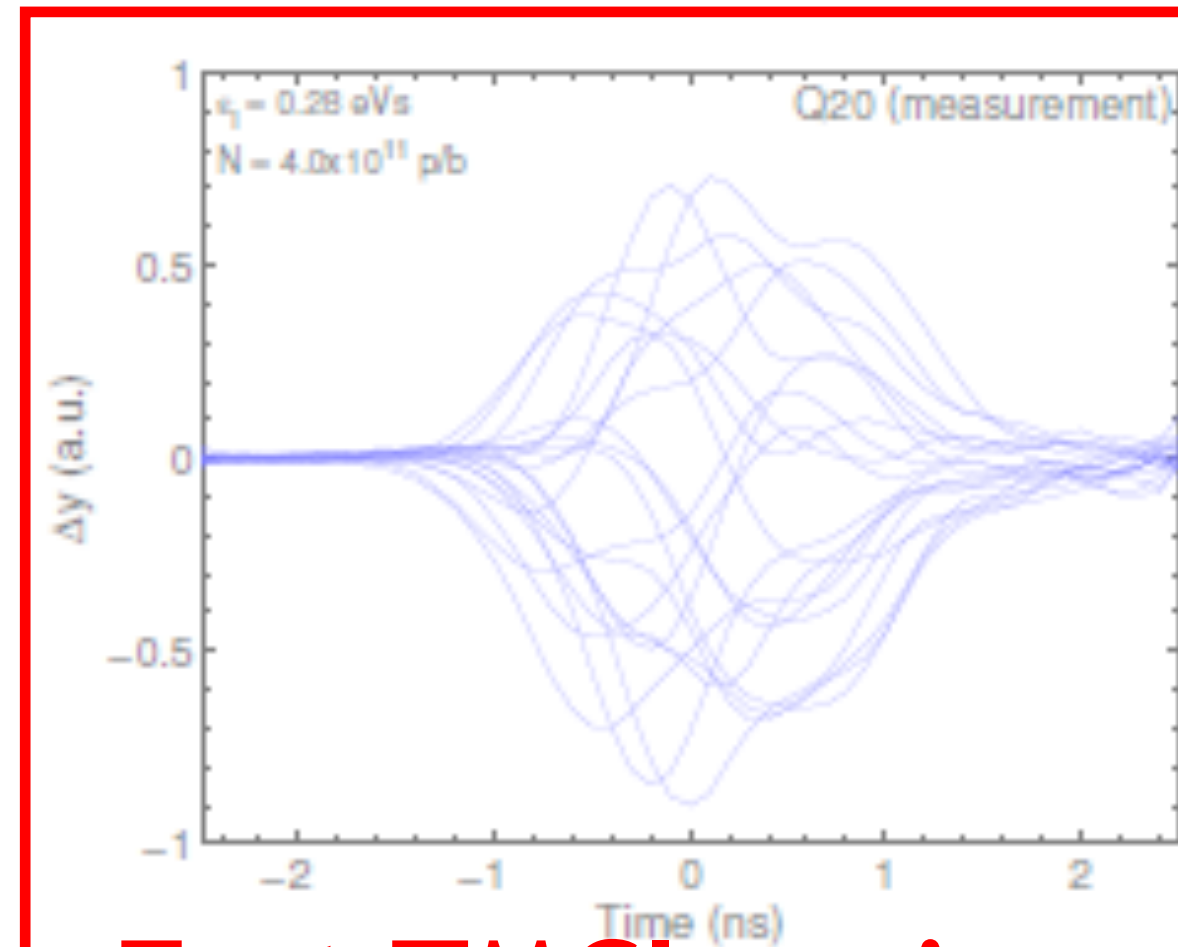
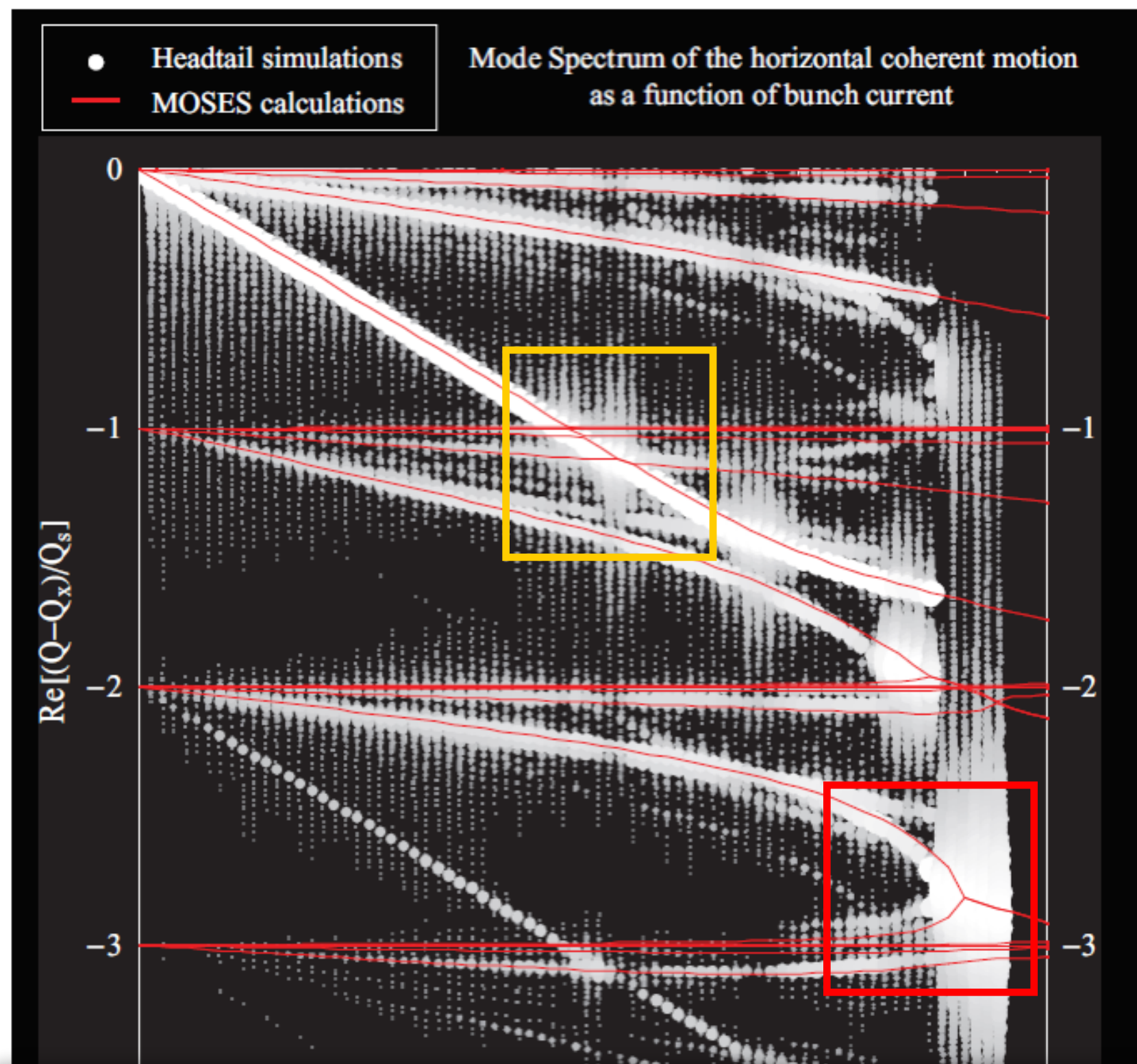

**Fast TMCI regime**

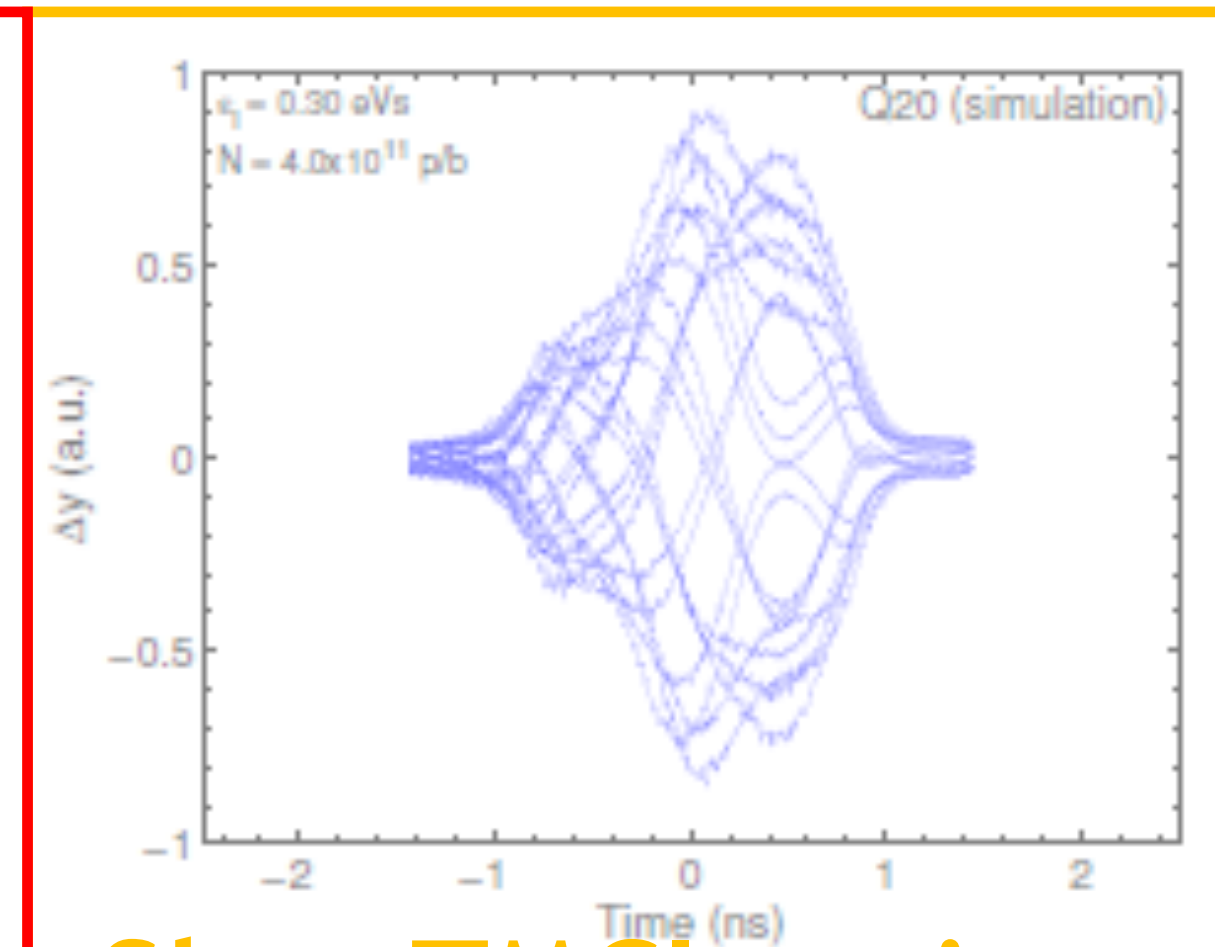

**Slow TMCI regime**

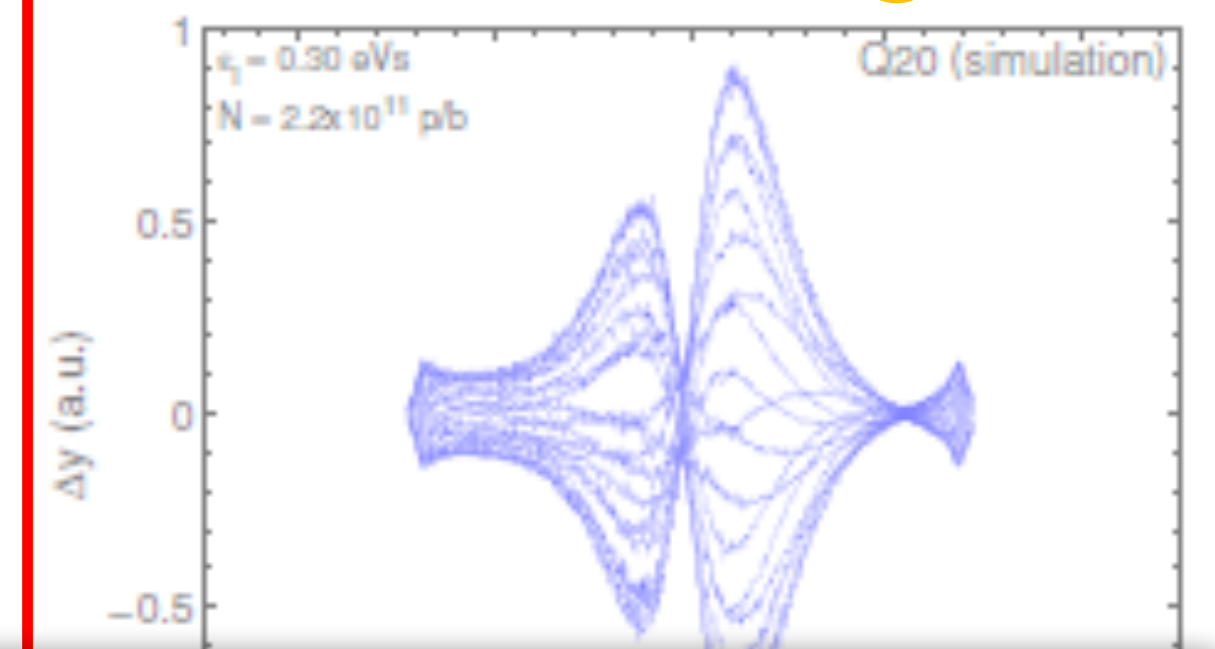
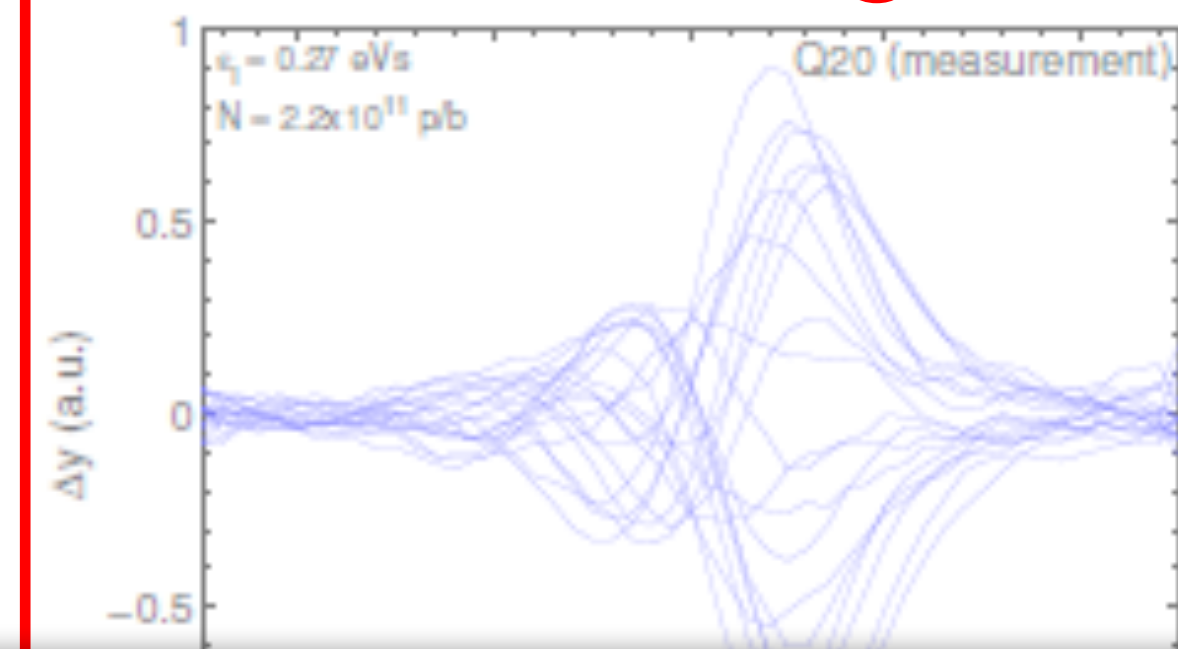

The Q20 TMCI threshold is out of the reach of the LIU parameters - the Q22 TMCI threshold, however, **dangerously approaches this.**