

Beam Diagnostics for the APS MBA Upgrade TUZGBD3 IPAC 2018

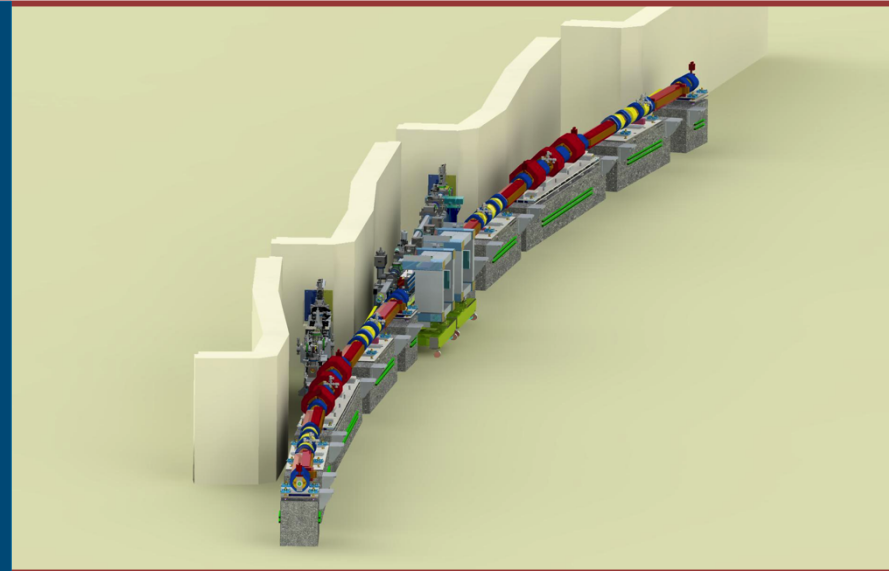

Nick Sereno

Diagnostics Group Leader
APS/Argonne National Laboratory
For the APS Beam Stability Team

2018 International Particle Accelerator Conference
May 1, 2018

APS Beam Stability Team

Many Groups Working on Beam Stability and Diagnostics

- ASD – Diagnostics:
 - R. Blake, A Brill, H. Bui, P. Dombrowski, L. Erwin, R. Keane, B. Lill, N. Sereno, X. Sun, B. X. Yang, P. Weghorn, R. Zabel
- AES – Controls:
 - N. Arnold, T. Fors, D. Paskvan, A. Pietryla, S. Shoaf, S. Xu
- ASD – Power Supplies:
 - B. Deriy, J. Wang
- APS Upgrade Vacuum:
 - H. Cease, B. Stillwell
- ASD – Accelerator Operations and Physics
 - L. Emery, V. Sajaev, M. Sangroula, H. Shang, A. Xiao
- APS Upgrade Project:
 - J. Carwardine, G. Decker, U. Wienands
- ANL Facilities:
 - M. Kirchenbaum, S. Stewart, G. Kailus

Outline

- Diagnostics for the MBA Ring
- Beam Stability Requirements
- RF BPM System Design
- Mechanical Motion System and R&D
- GRID X-ray BPM
- Beam Size Measurement Design Considerations
- Orbit Feedback System Design and R&D
- Summary

MBA Ring Design

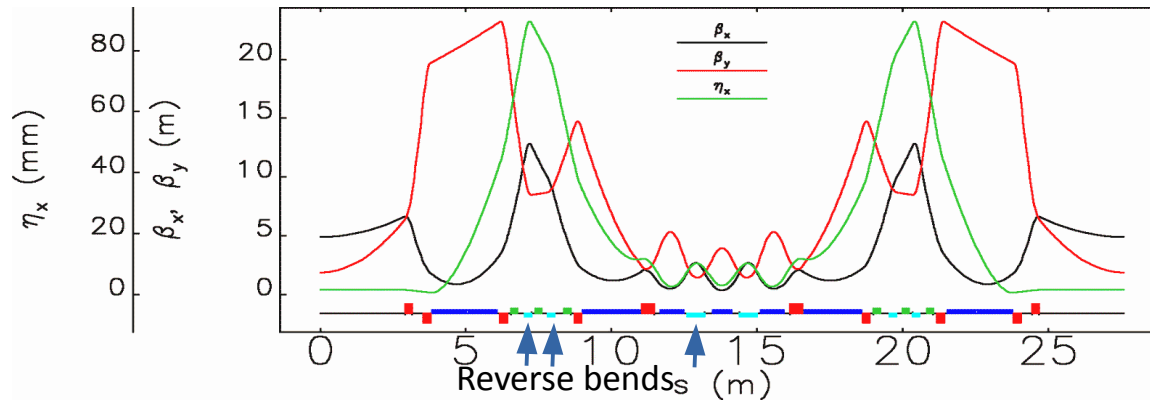

Invited Talk: THXGBD1
Aimin Xiao

Quantity	APS Now	APS MBA	APS MBA	Units
		Timing Mode	Brightness Mode	
Beam Energy	7		6	GeV
Beam Current	100		200	mA
Number of bunches	24	48	324	
Bunch Duration (rms)	34	104	88	ps
Energy Spread (rms)	0.095	0.156	0.130	%
Bunch Spacing	153	77	11	ns
Horizontal Emittance	3100	32	42	pm·rad
Emittance Ratio	0.013	1	0.1	
Horizontal Beam Size (rms)	275	12.6	14.5	μm
Vertical Beam Size (rms)	11	7.7	2.8	μm
Betatron Tune	35.2, 19.27		95.1, 36.1	
Natural Chromaticity	-90,-43		-130, -122	

- Diagnostics for the MBA Ring driven by small beam size
 - Beam Stability Requirements
 - Emittance Measurement Diagnostics

Diagnostic Systems For the MBA Ring

Diagnostic	Quantity/Sector	Total
Arc RF BPMs	12	480
ID RF BPMs (A:P0, B:P0)	2	80
Canted ID RF BPMs (C:P0)	1	10
Orbit Feedback System	N/A	1
Mechanical Motion Systems	1	35
Current Monitors	N/A	2
Bunch Current Monitor	N/A	1
Beam Size Monitors	N/A	3
Transverse Multi-bunch Feedback	N/A	1
X-Ray BPM Electronics GRID	1	35

570 rf BPMs

Beam Stability Requirements

- Beam stability requirements are set at a fraction of the particle beam phase space (x, x', y, y') dimensions, typically 10% at the ID source points

Plane	AC rms Motion (0.01-1000 Hz)		Long Term Drift (7 Days)	
Horizontal	1.3 μm	0.25 μrad	1.0 μm	0.6 μrad
Vertical	0.4 μm	0.17 μrad	1.0 μm	0.5 μrad

Present APS has ~5 times these values with bandwidth up to 100 Hz

RF BPM Requirements

Beam Position at Insertion Device	Specification Limit	Condition
AC (0.01Hz-1kHz)	Resolution 250 nm rms	range: +/- 2mm
Drift (period of 1 week)	1 μm	range: +/- 2mm
Beam Position at Arcs	Specification Limit	Condition
AC (0.01Hz-1kHz)	Resolution 400 nm rms	range: +/- 2mm
Drift (period of 1 week)	2 μm	range: +/- 2mm

RF BPMs*

- Baseline design uses Libera Brilliance+ by ITech
 - < 60 nm rms AC noise 0.01 to 1000 Hz
 - < 50 nm pk-pk drift over 7 days
 - < 30 μm single shot rms noise for 1 nC typical commissioning charge levels
- 40 Shielded EMI enclosures for BPMs and feedback system electronics.
- BPM pickup electrode assembly has integrated shielded bellows designed in coordination with vacuum design group.

Libera Brilliance Plus electronics

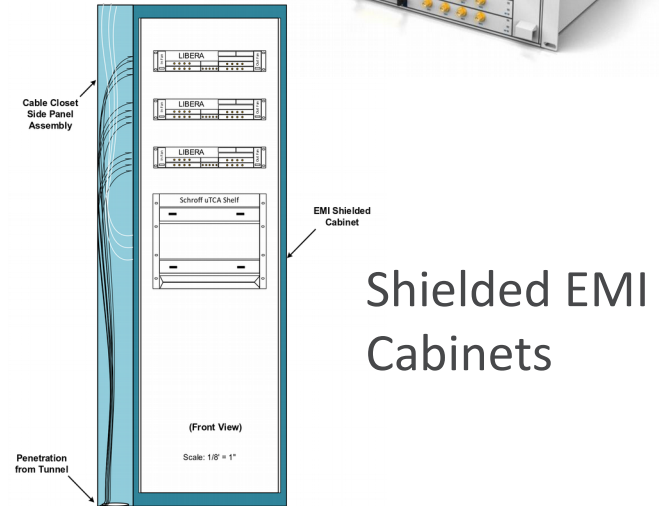

Shielded EMI Cabinets

BPM with integrated shielded bellows

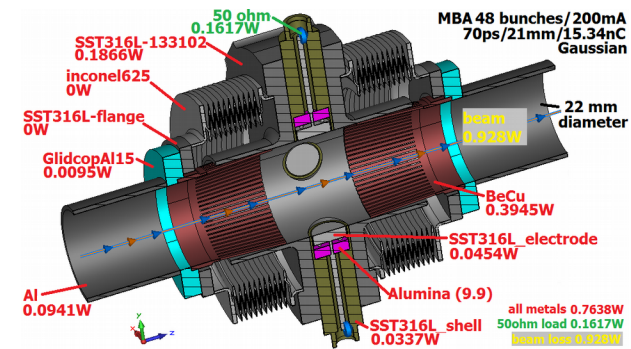

* R. Lill et al. IBIC 2016, Barcelona, Spain 2016
 X. Sun et al. IBIC 2017, Grand Rapids, MI, 2017

RF BPM Pickup Electrode Design

Fill Pattern	Mode	Current (ma)	Single bunch current (ma)	Bunch charge (nC)	Bunch length (ps/mm)
48	User	200	4.2	15.34	75.8/22.7
324	User	200	0.6	2.27	56.1/16.8
Single	Studies	1	1	3.68	57/17.1

- Assembly designed with the vacuum group
- For MBA 8 mm button conducted trade-off studies on critical design parameters.
 - Signal strength (324 bunches)
 - Matching vs ability to braze feedthroughs
 - Machine impedance
 - **Assembly power dissipation budget (0.42 watts with 48 bunch 200 mA)**
- Designed and ordered prototypes from 2 vendors for qualification testing. (Settled on one vendor)
- Beam Testing of assembly in APS SR (Fall 2018)
 - Noted CST simulation showed bellows mechanical displacement effect on beam position

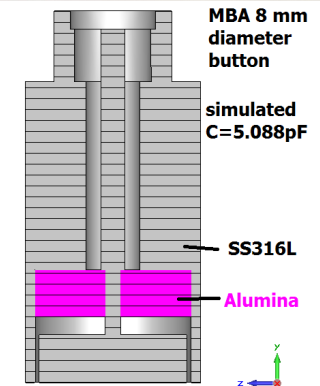
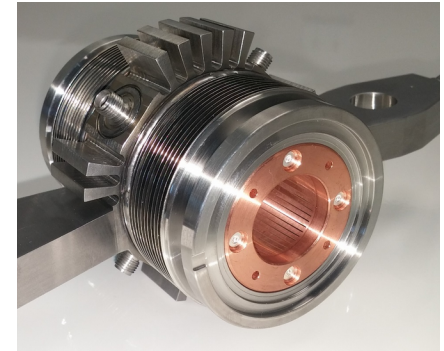

BPM Prototypes from two vendors

- Units from both vendors were tested for electrical performance with encouraging results.

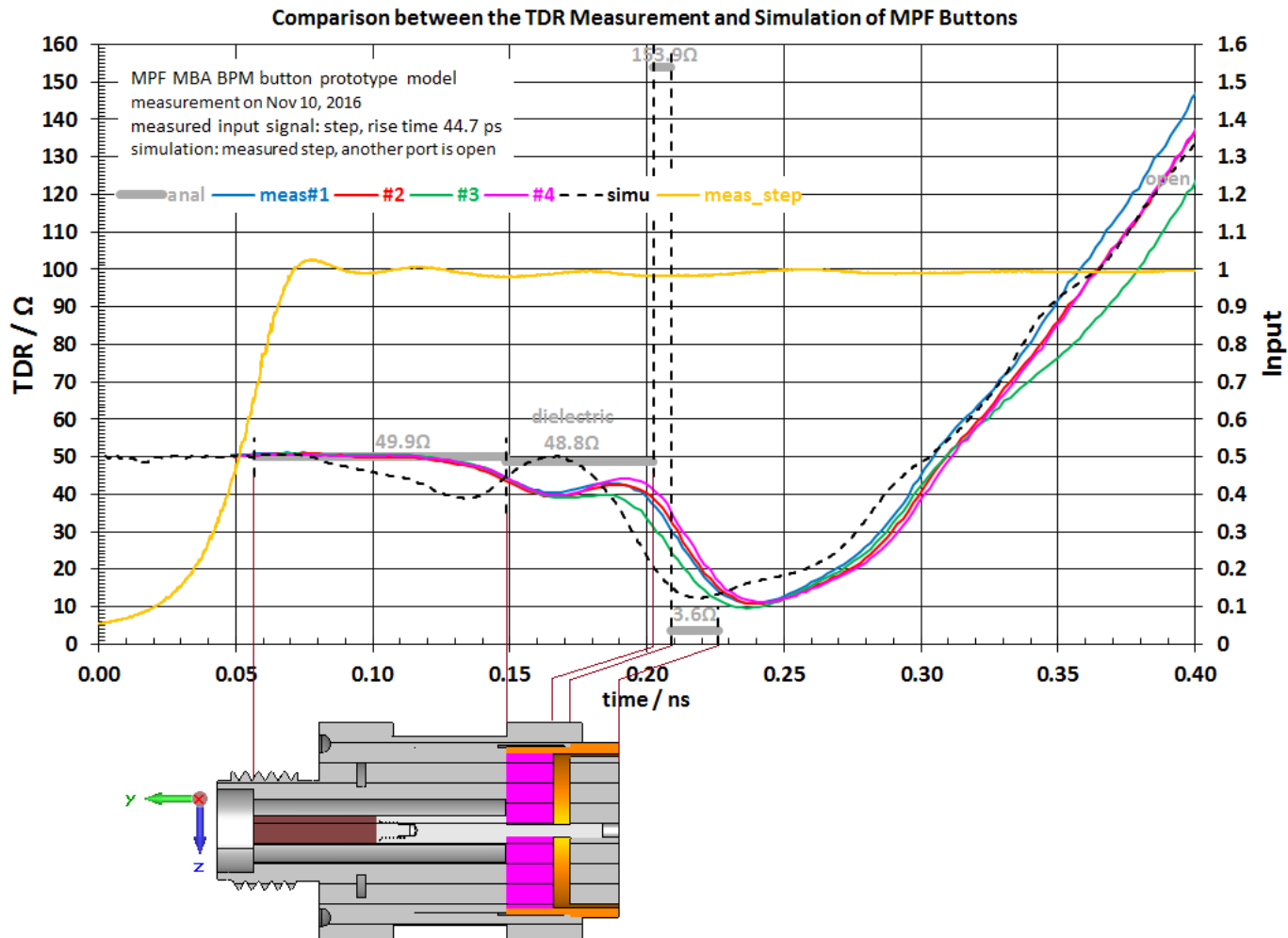

Goubau Line Test Setup*

Minimize the size of cavity to reduce effect of trapped modes

Use small slots to shield low-frequency EM fields

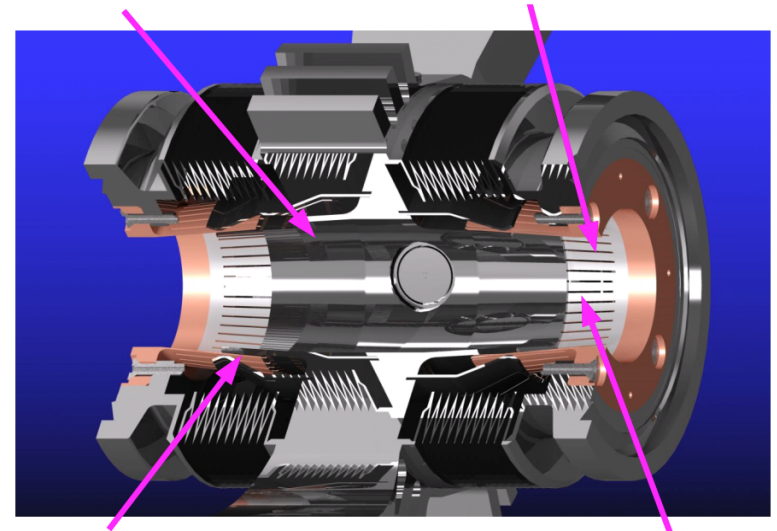
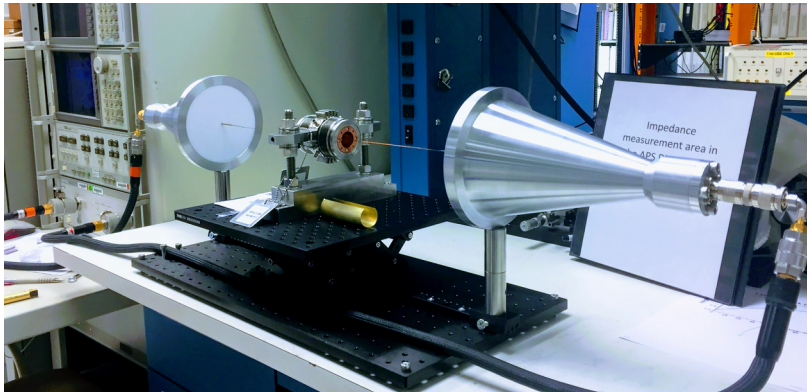

Gradual tapering to different dimensions

Plate poor conductors with good conductors (if possible)

- A Goubau line based test fixture has been designed and built to characterize coupling impedance of various accelerator components (S_{21} measurement)
- G-line test fixture provides a wide-band (beam like) test signal
- The EM waves are launched onto the wire by the cones and propagate through the device under test (DUT) to the receiving antenna where the signals are terminated

*M. Sangroula et al. Poster THPAK005, IPAC 2018

Gaubau Line S_{21} Measurements

- RF-gap found

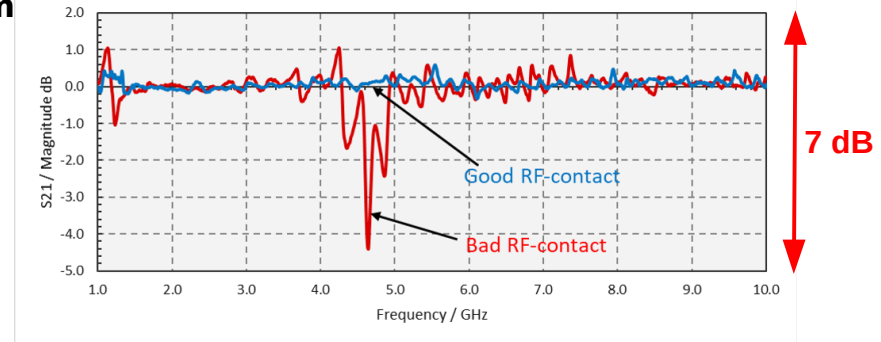
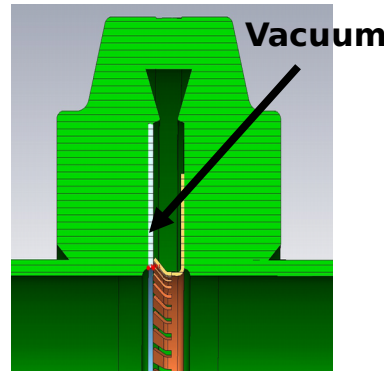
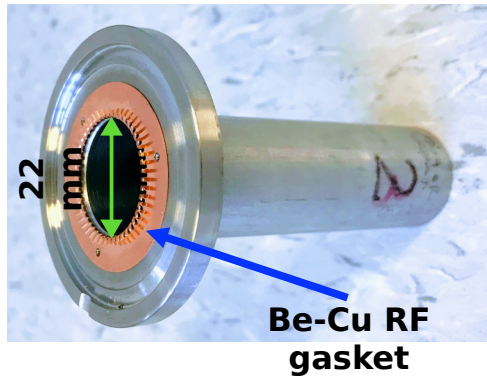

Measured and simulated response comparison for a prototype BPM-bellows assembly

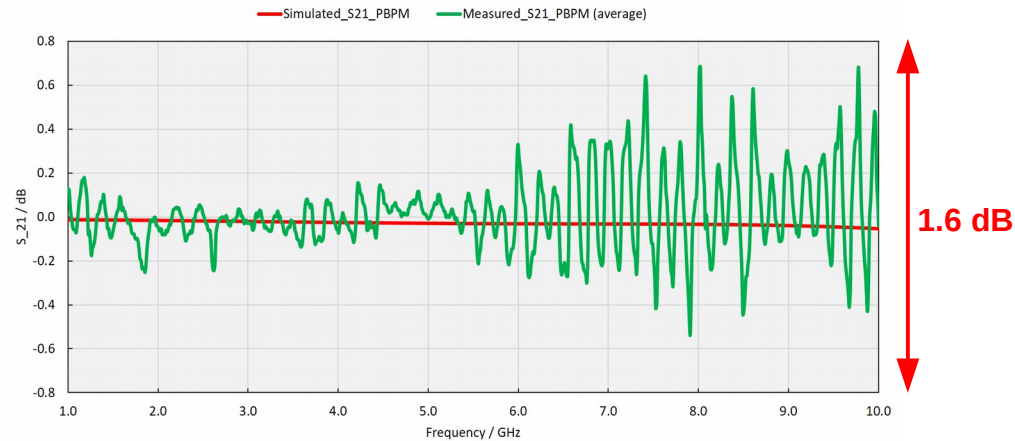
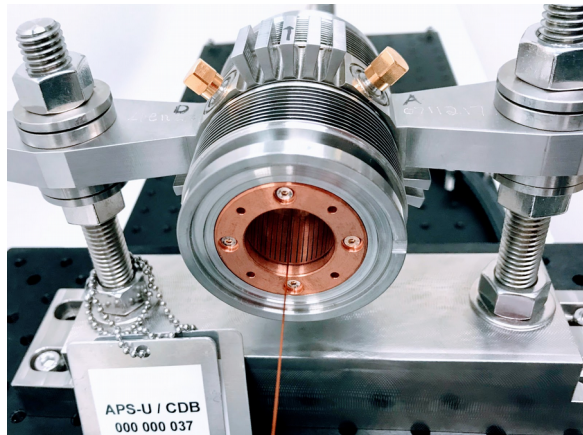

- Discovered an air gap in a flange gasket that resulted in high frequency resonant response (high loss at ~4.75 GHz)
- BPM bellows indicate only a broadband low-loss response indicating they are designed properly

Mechanical Motion Measurement Systems (MMS)*

Correct raw bpm position for long-term mechanical movement of the vacuum chamber

- Instrument BPMs with capacitive detectors and hydrostatic detectors
- Tested system in Sector 27 at rf “P0” BPM and GRID X-ray BPM
- Final R&D design phase of the MMS instruments the X-Ray BPM inside the user hutch.
- Used data from the system to both inform the design and show how to correct bpm position for mechanical motion

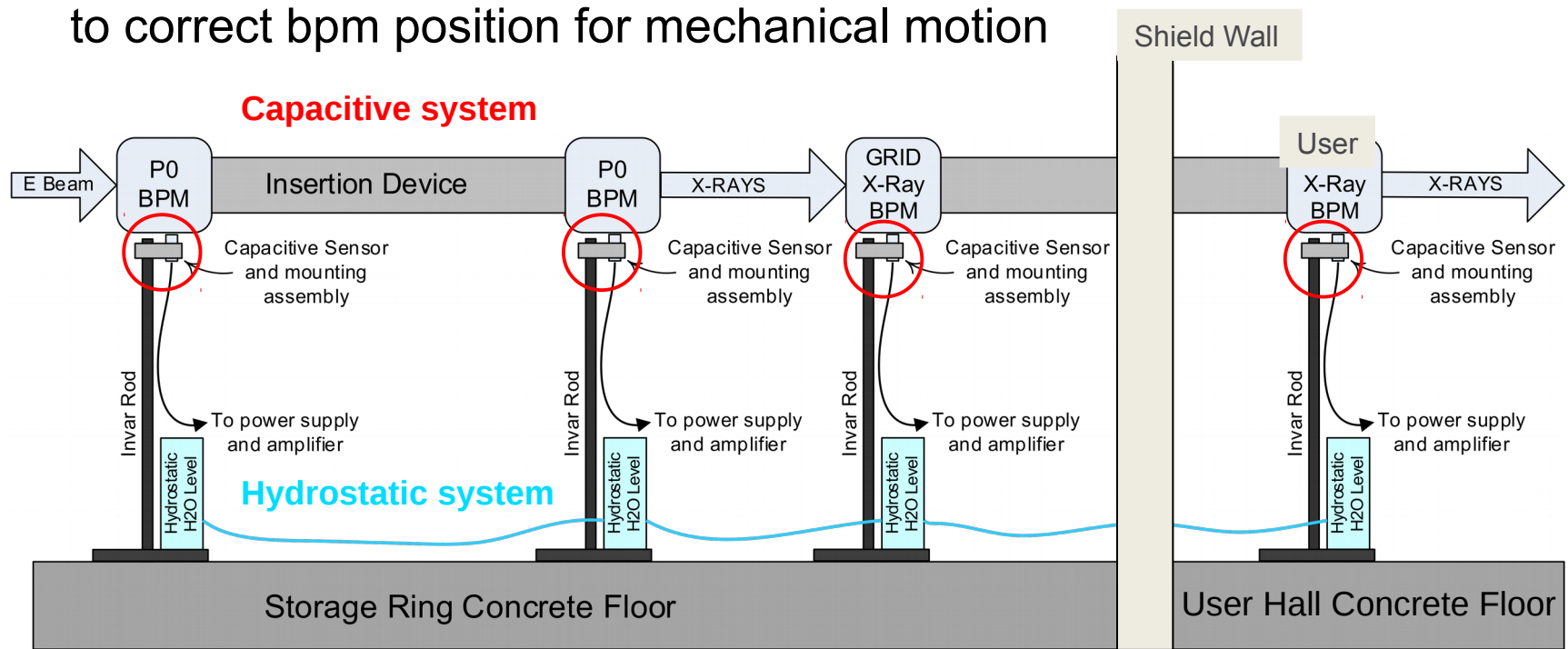

MMS Design

Capacitive electrode and heater

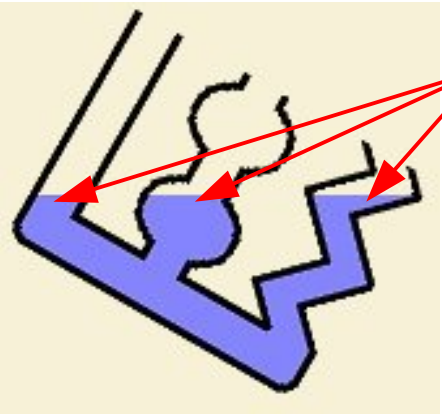
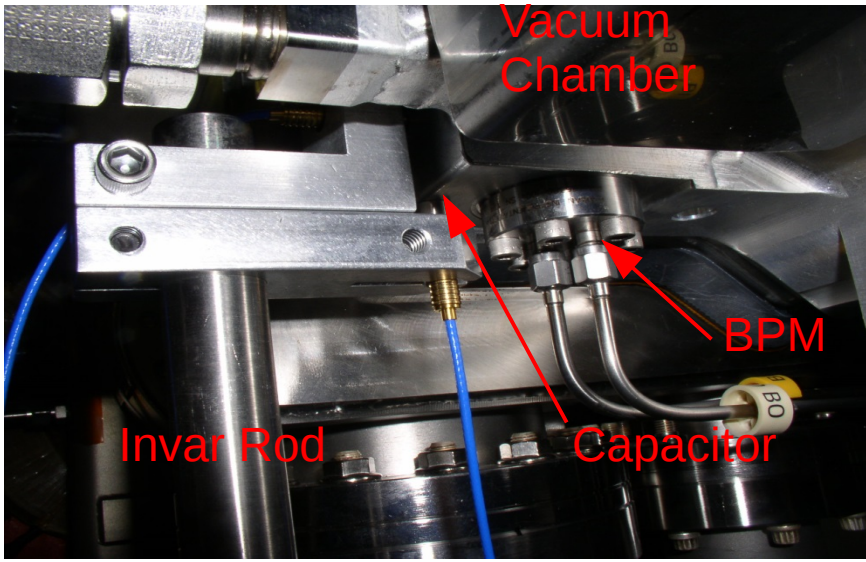
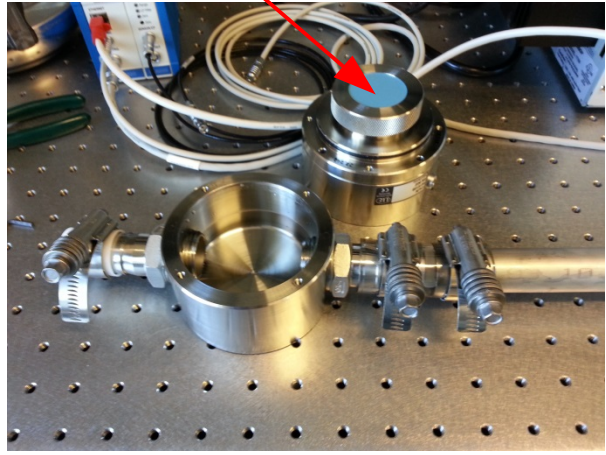

Communicating Vessels:
 H_2O level is the same relative to ground no matter the orientation or shape of the vessels
Provides an absolute vertical Reference

- P0 rf BPMs for the MBA are now planned to be moved off ID vacuum chamber and have an isolated invar support system similar to NSLS-II

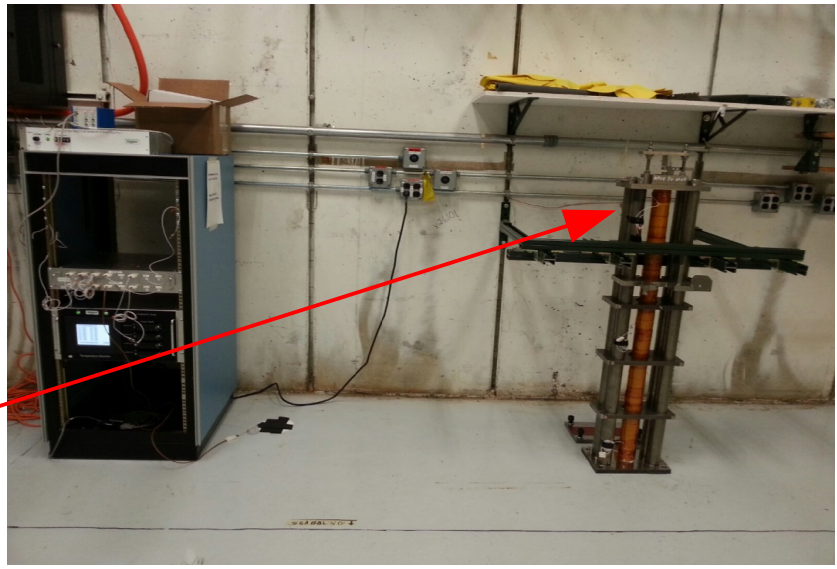

MMS Correction of Raw BPM Position Using Orbit Feedback*

Successive Predictions at the GRID Using MMS Data For Week 10-25-16

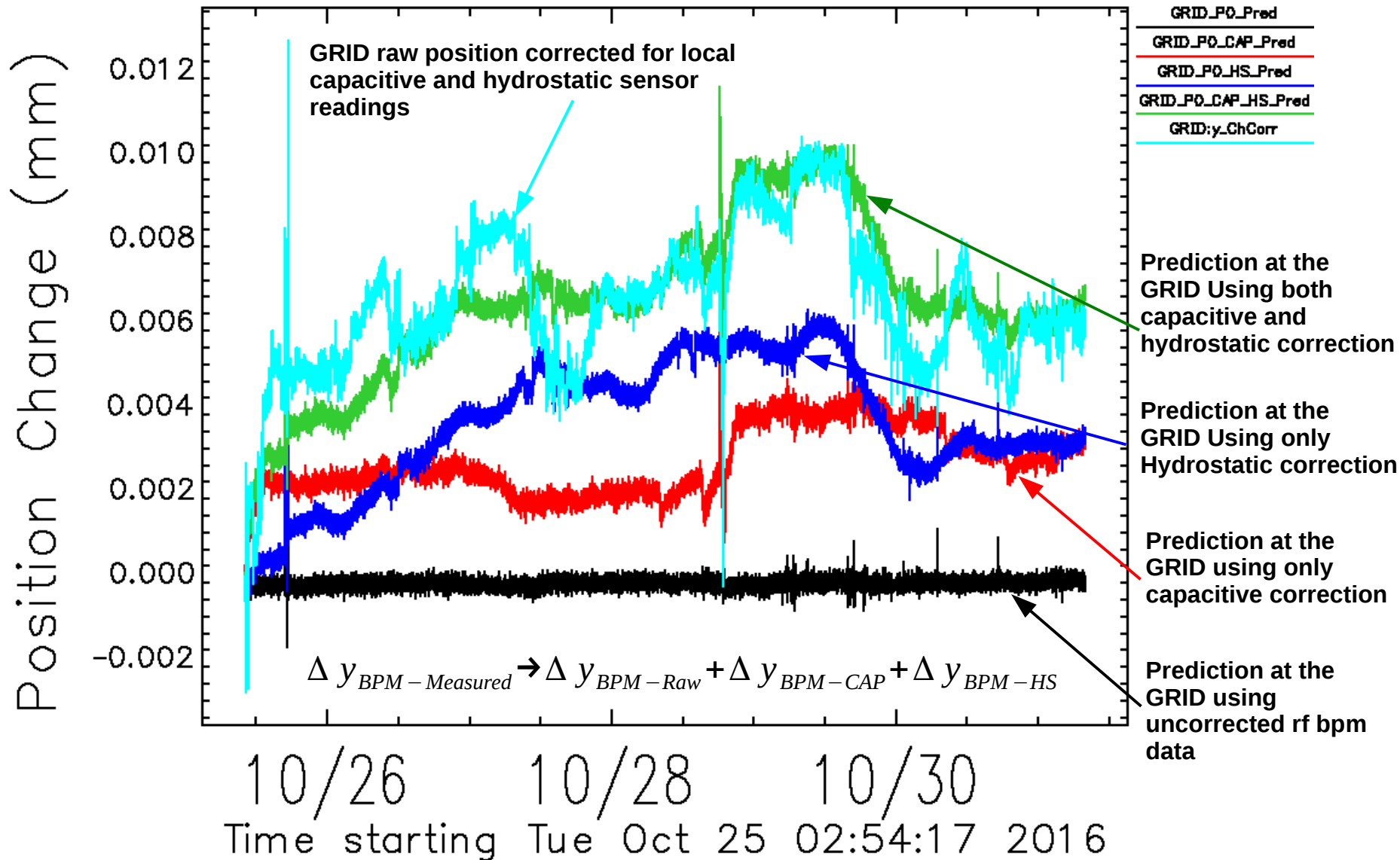

GRID-XBPM Prototype Design*

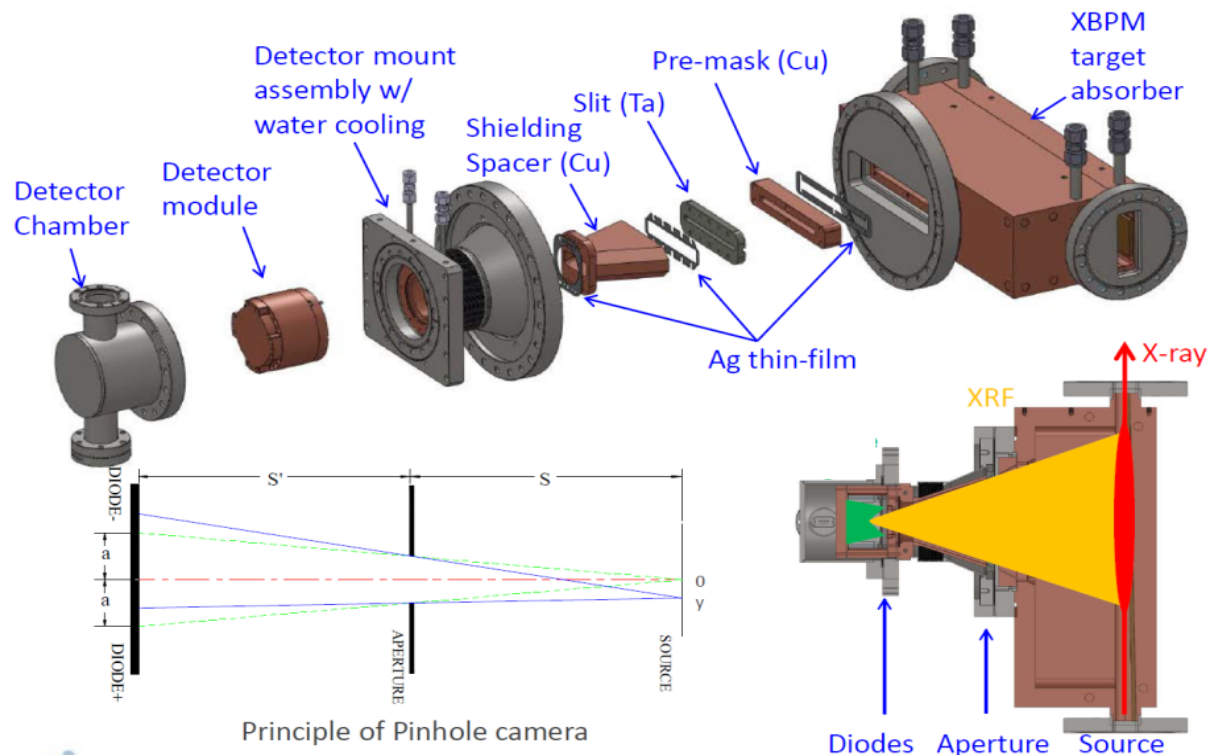

- 27-ID GRID installed for R&D and User Operations since Summer 2015
- Based on interception of hard X-rays and fluorescence by Cu (GridCop)
- Vertical position obtained from pinhole imaging by each detector assembly
- Horizontal position obtained from difference over sum between upstream and downstream detectors
- Final engineering of system underway due to higher energy/flux bend magnet/quad backgrounds in 42 pm emittance MBA ring

*B. X. Yang et al. IPAC 2015, Richmond, Va. 2015
B. X. Yang et al. IBIC 2016, Barcelona, Spain, 2016
G. Decker, PAC 2007, Albuquerque, NM, 2007

GRID-XBPM Prototype Performance

- GRID Prototype installed in S27 Front-end factor of 30 better signal to background
- Old PE XBPMs make use of the Decker distortion

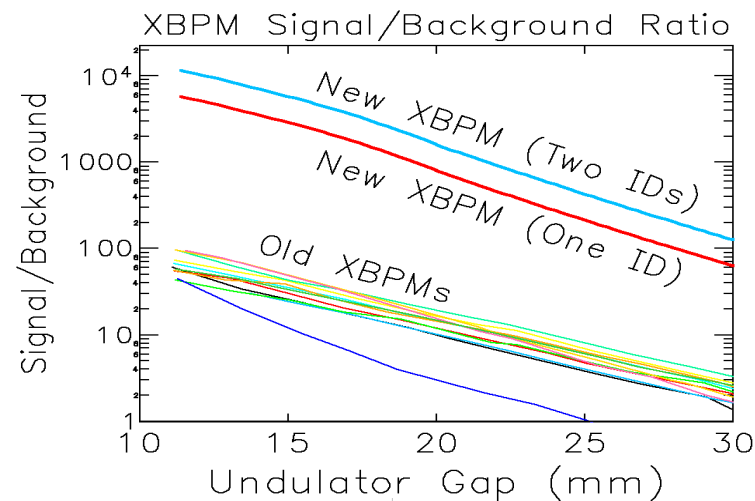

Horizontal beam positions in 60-days of User Operations

Vertical beam positions in 60-days of User Operations

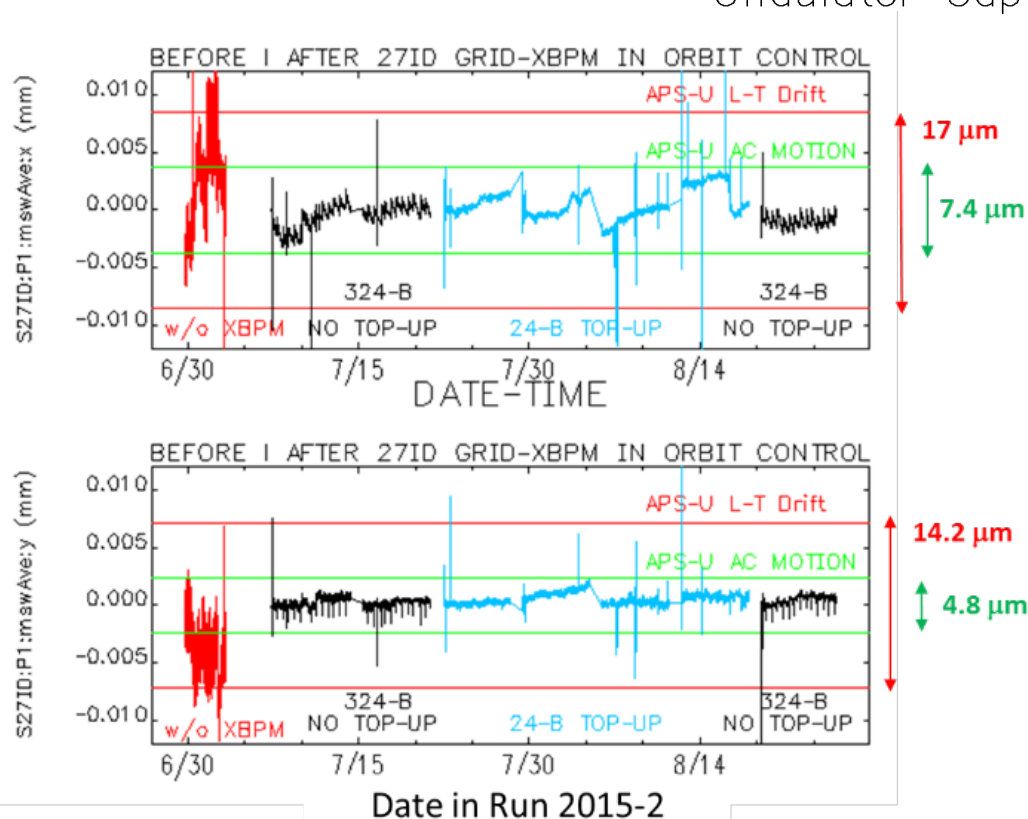

Beam Size and Emittance Measurement Design Considerations*

- The A:M1 source is very important to successful APS-U storage ring emittance diagnostics:
 - Low dispersion allows for clean emittance measurements
 - Larger beam sizes relax resolution requirements compared to other possible lattice sources
- Four measurement techniques are considered to cover all expected beam conditions and smallest expected emittance of 4 pm-rad
 - For absolute beam size measurements, we will use a pinhole camera (8-100 μm), a wide aperture Fresnel diffractometer (4-16 μm) and a Young's double-slit interferometer (1-5 μm).
 - For relative beam size changes, 1-D double-slit collimator will be used to monitor normalized peak intensities.
- Coherence preservation is the most important concern.

Orbit Feedback System*

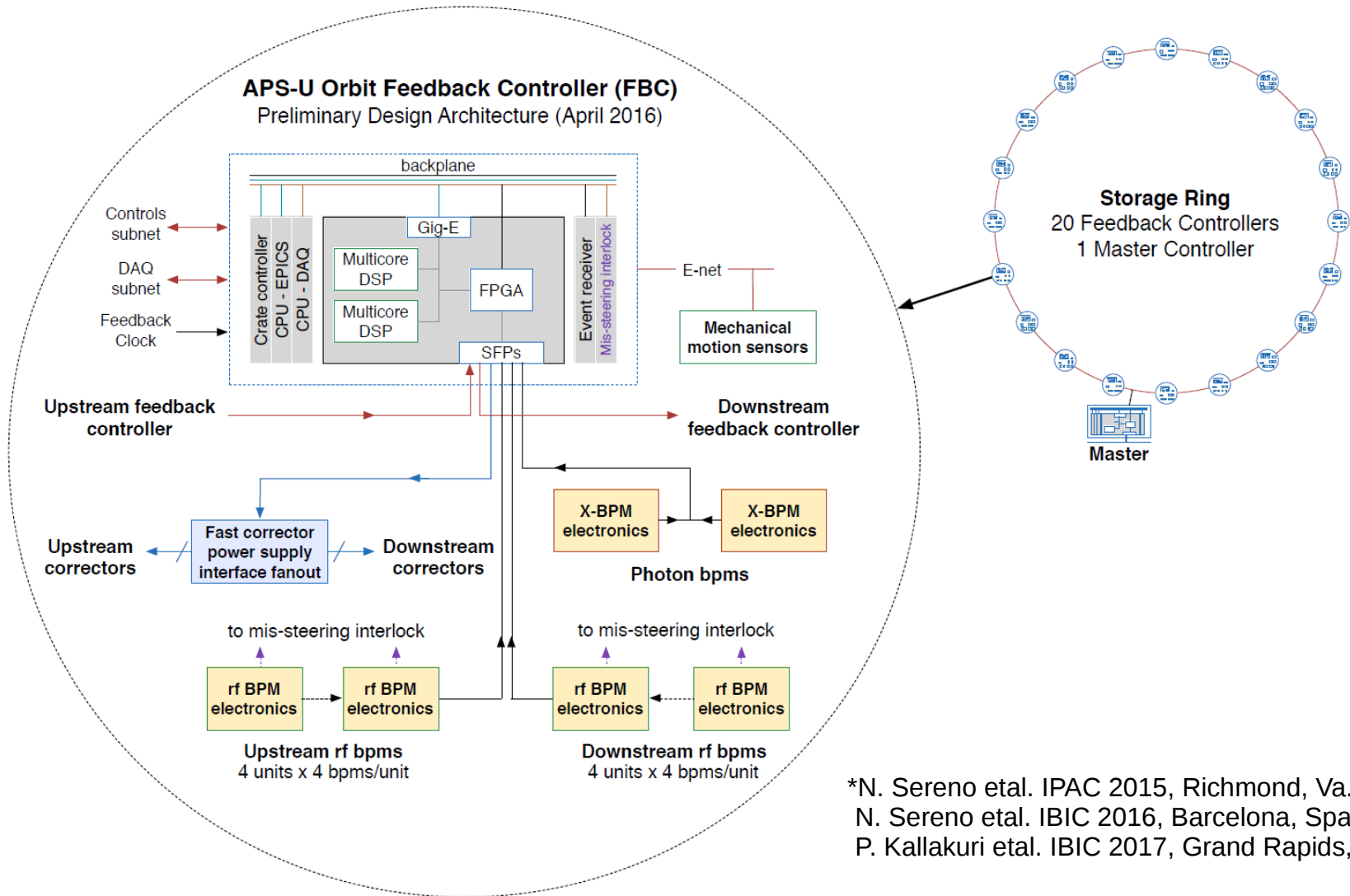

Integrated Beam Stability R&D in APS Sector 27

Major systems tested: BPM Electronics, Fast Corrector PS, Feedback Controller

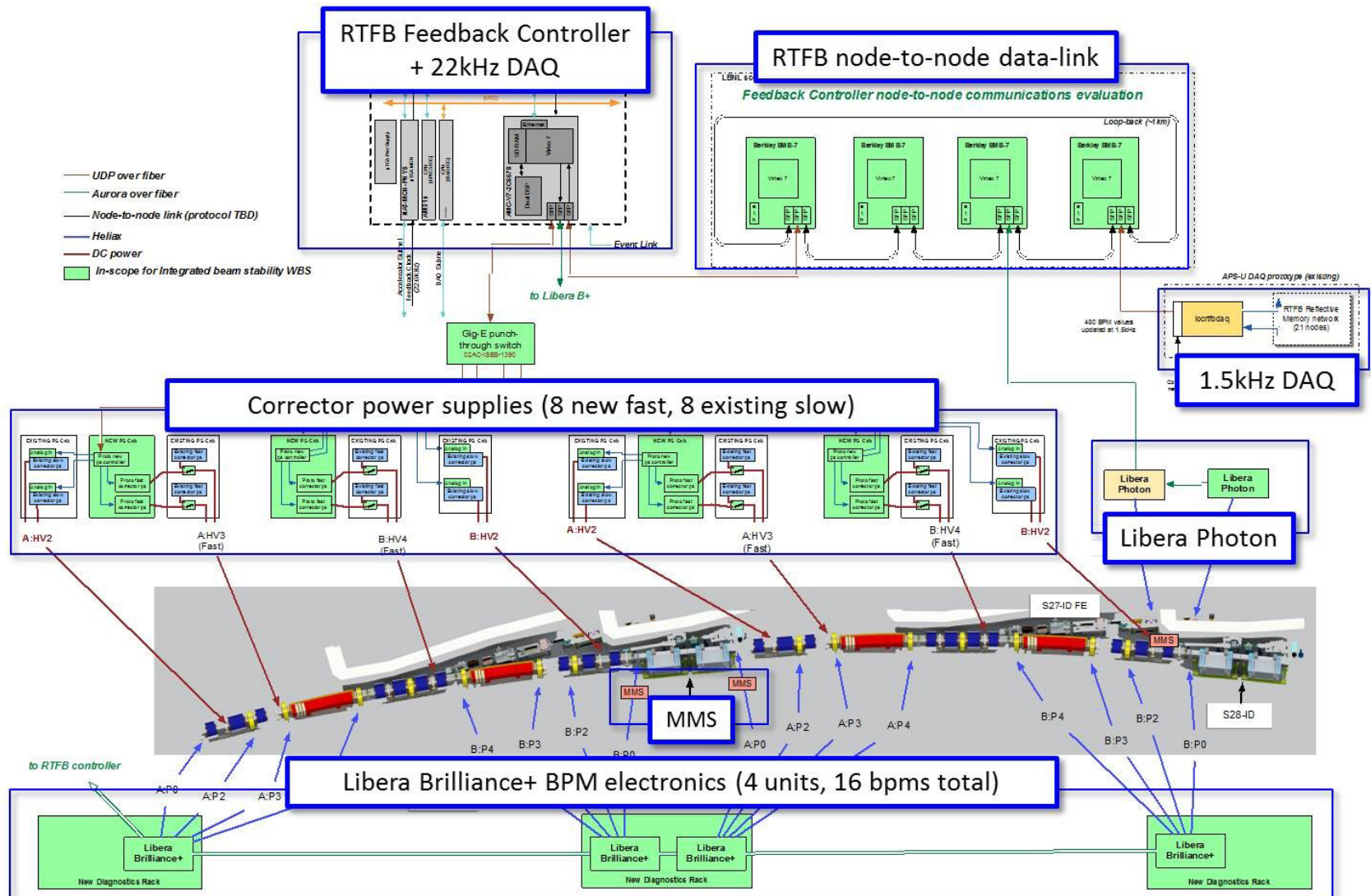

RMS beam stability test at S27 with 22.6 kHz sampling rate and unified feedback (rms beam motion)

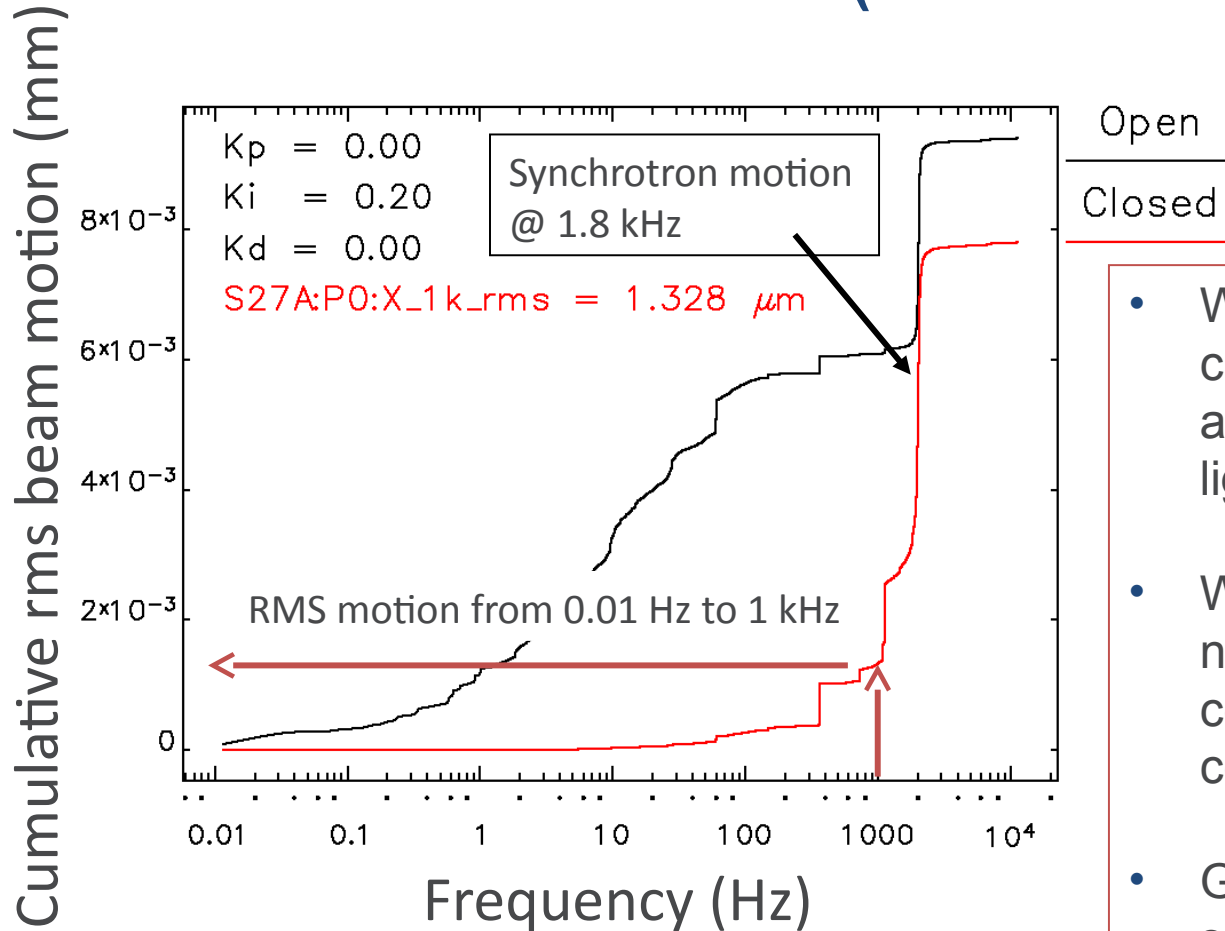

- We have demonstrated closed-loop orbit feedback at 22kHz (highest of any light-source)
- We have demonstrated a new unified algorithm that combines slow and fast correctors
- Good progress on matlab simulation of the full MBA feedback system

We are near spec for AC stability (400 nm vertical and 1300 nm horizontal)
Achieved > 700 Hz closed loop bandwidth

Closed Loop Bandwidth Record Achieved During studies: 4-25-2018 Horizontal Plane

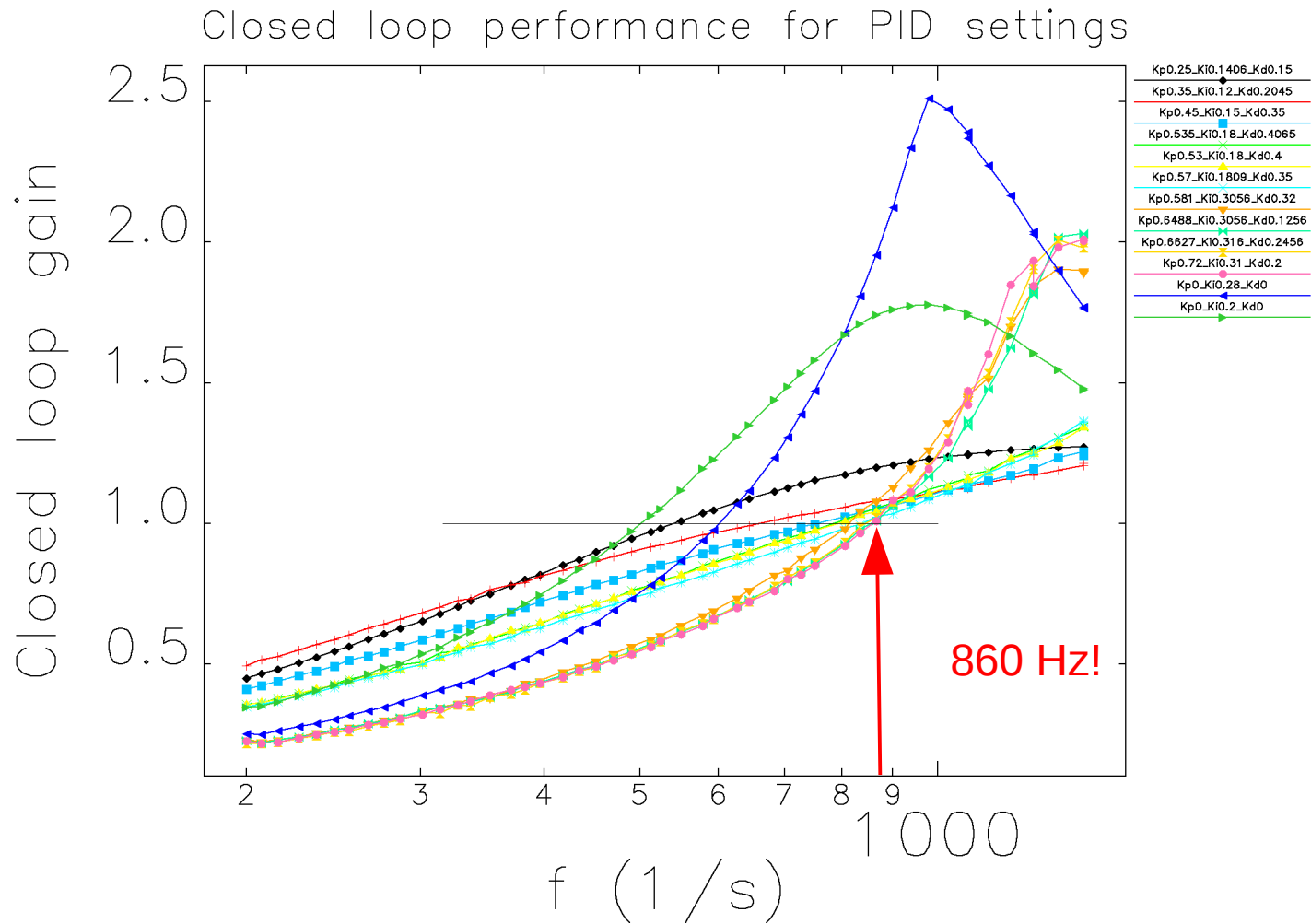

Summary

- MBA diagnostics must deliver unprecedented beam stability and be able to measure ultra small beam size for emittance measurements
- Significant progress has been made developing the design of the primary diagnostics for the MBA ring
- Integration and R&D testing in sector 27 has informed MBA design and given the team confidence that demanding MBA requirements can be met
- We now look forward to conclusion of the R&D program and proceeding to final design in the coming year