

PROTECT +
ENHANCE +
SAVE LIVES



Design and Simulation Tools for the High-Intensity Industrial Rhodotron Accelerator

Wiel Kleeven (on behalf of the IBA R&D team)

Ion Beam Applications (IBA)

Louvain-la-Neuve, Belgium

Willem.kleeven@iba-group.com

INDUSTRIAL &
STERILIZATION
SOLUTIONS



Outline of this presentation

- Intro
 - About IBA (2 slides)
 - Rhodotron accelerator and its applications (4 slides)
- Simple optics
 - Hard-edge models for transverse and longitudinal optics (4 slides)
- EM-fields for particles tracking
 - 3D RF cavity fields and 3D magnetic field computations (2 slides)
- Full 3D particle tracking with space charge (1 slide)
- Egun simulations (1 slide)
- Conclusions (1 slide)

Total: 18 slides

IBA – Ion Beam Applications

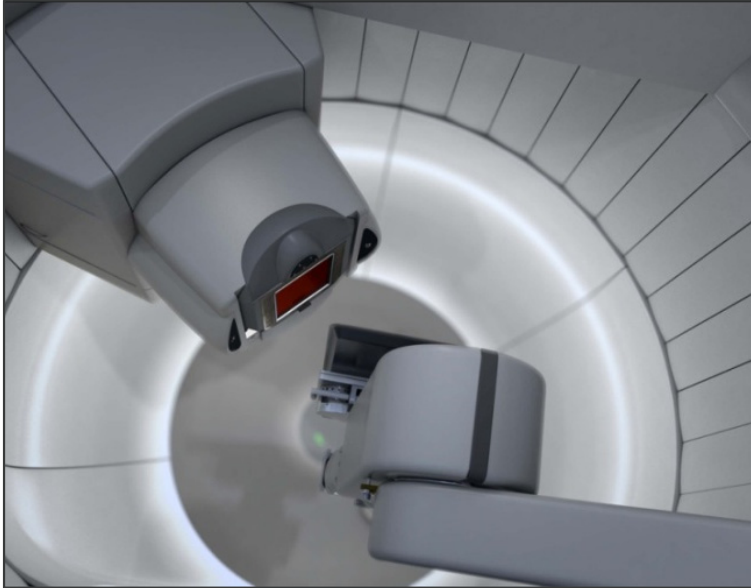

- Based at LLN in Belgium
- Founded in 1986 by Yves Jongen
 - Spin of from university UCL
 - Founded the developement of an industrial 30 MeV cyclotron

NOWADAYS

Over **400**
accelerator systems
installed worldwide

~270 M€ sales (2015)
~1600 employees
worldwide,
40 nationalities

R&D:

- 12% of turnover
- 13% of workforce

Patent portfolio
(2016): 510 patents &
patent applications,
for 102 innovations

IBA Main Activities



Proton Therapy

Cancer treatment

**Cyclotron based
particle therapy**

Patient and machine QA

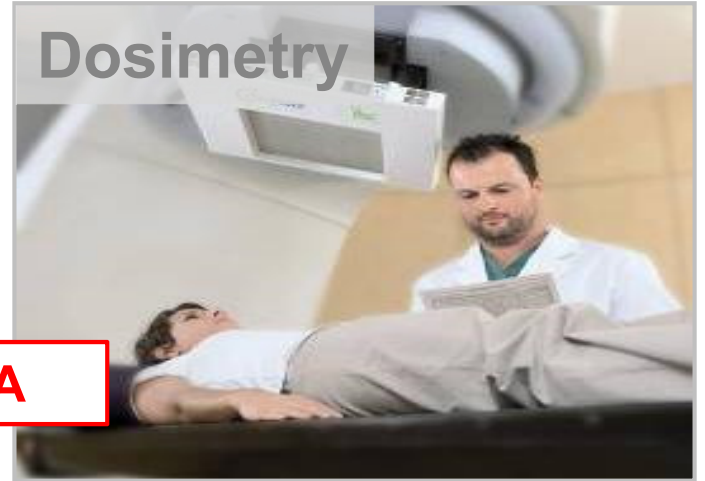

Dosimetry



RadioPharma

Cancer diagnostic

**Cyclotrons and
Radiofarmaceutical
synthesis**

Industrial applications



Industrial

Main Characteristics of the Rhodotron Accelerator

- A compact cw high intensity industrial recirculating electron accelerator
- Energies in the range of 1 to 10 MeV
Average beam powers in the range from 10 kW to almost 1 MW
- RF frequencies in the range from 100 MHz up to 400 MHz
- Recently, also pulsing was developed
 - Reduce average wall power
 - Smaller cavities (TT50)
 - Higher energies possible (40 MeV)



Main Characteristics of the Rhodotron Accelerator

- A compact cw high intensity industrial recirculating electron accelerator
- Energies in the range of 1 to 10 MeV
Average beam powers in the range from 10 kW to almost 1 MW
- RF frequencies in the range from 100 MHz up to 400 MHz
- Recently, also pulsing was developed
 - Reduce average wall power
 - Smaller cavities (TT50)
 - Higher energies possible (40 MeV)

Rhodotron product range



TT50 Super Compact 10 MeV



Up to 20Kw, 2mA



TT100 Compact 10 MeV



40kW, 4mA



TT200 Standard 10 MeV



100kW*, 10mA



TT300 High power 10 MeV



245kW*, 35mA



TT1000 High power 7 MeV



560kW*, 80mA

Main Characteristics of the Rhodotron Accelerator

- A compact cw high intensity industrial recirculating electron accelerator
- Energies in the range of 1 to 10 MeV
Average beam powers in the range from 10 kW to almost 1 MW
- RF frequencies in the range from 100 MHz up to 400 MHz
- Recently, also pulsing was developed
 - Reduce average wall power
 - Smaller cavities (TT50)
 - Higher energies possible (40 MeV)

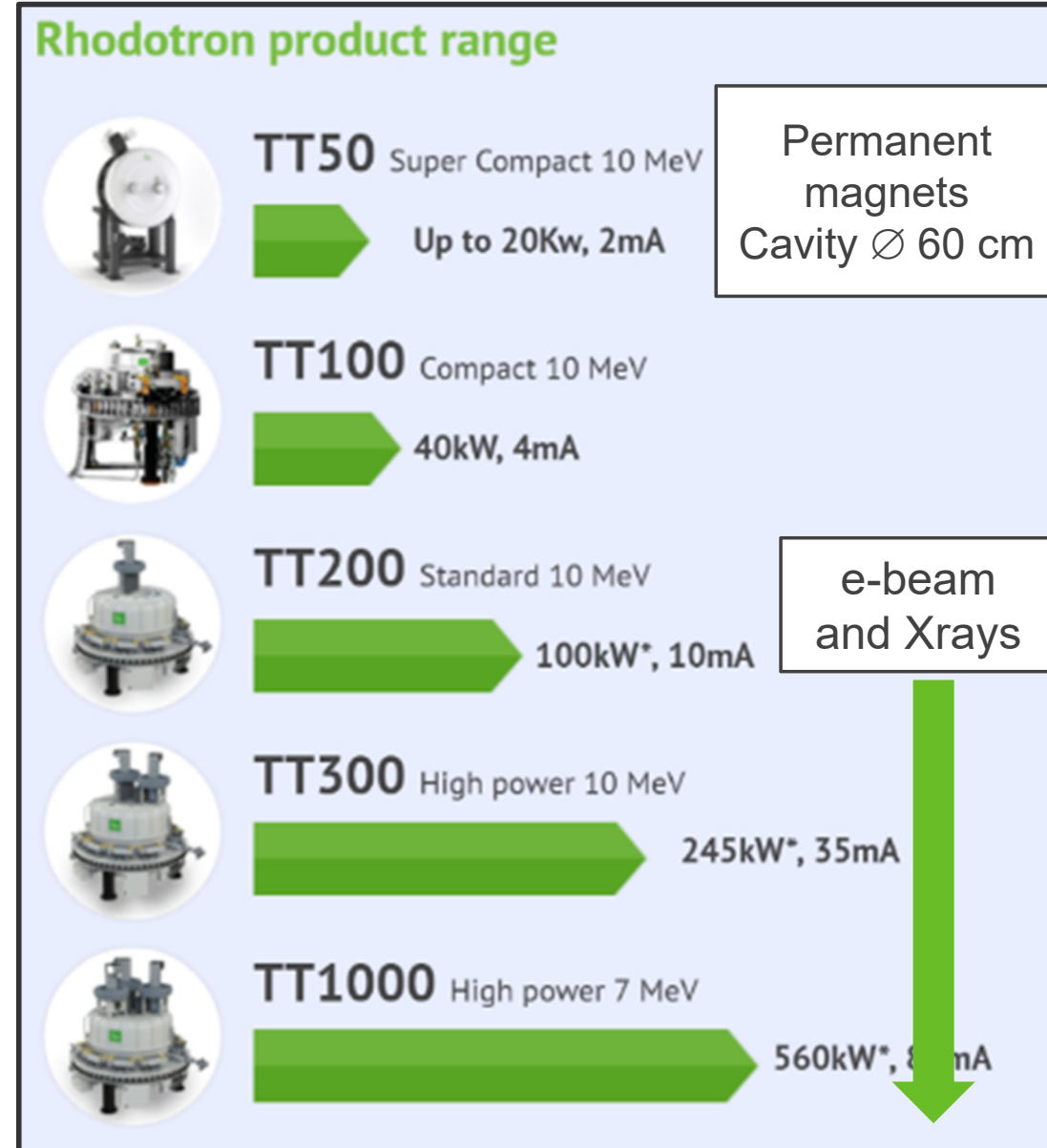

Main Applications

- Sterilization
 - Ionizing radiation of e-beam or X-ray
 - damages DNA \Rightarrow living cell cannot reproduce
 - Mainly used for medical disposables
 - Injection needles, syringes, bandages,....



Main Applications

- Sterilization
 - Ionizing radiation of e-beam or X-ray
 - damages DNA \Rightarrow living cell cannot reproduce
 - Mainly used for medical disposables
 - Injection needles, syringes, bandages,....
- Polymer cross-linking
 - Wire and cable market
 - Applications requiring limited space, high T, low weight, long life time
 - Automotive, aerospace, solar technology, ...

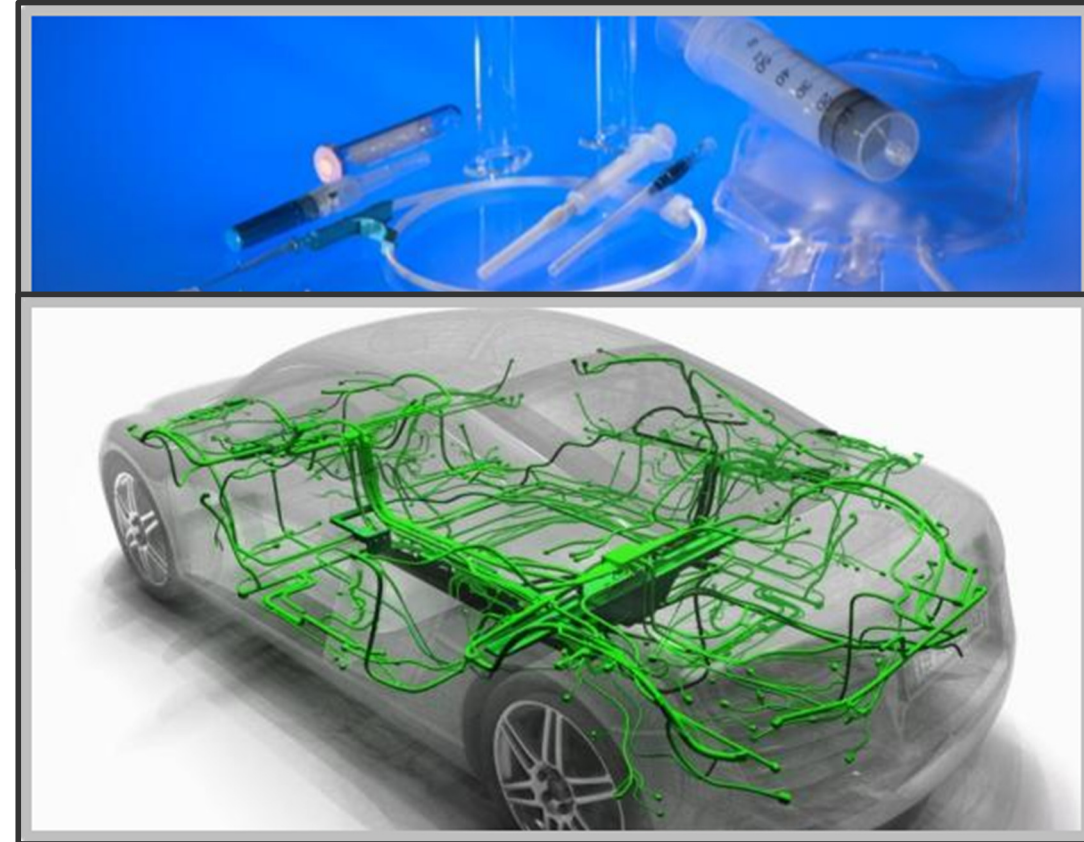

Main Applications

- Sterilization
 - Ionizing radiation of e-beam or X-ray
 - damages DNA \Rightarrow living cell cannot reproduce
 - Mainly used for medical disposables
 - Injection needles, syringes, bandages,....
- Polymer cross-linking
 - Wire and cable market
 - Applications requiring limited space, high T, low weight, long life time
 - Automotive, aerospace, solar technology, ...
- Others
 - Food treatment
 - Cargo screening
 - Mail sanitization
 - Colouring of Gemstones
 -

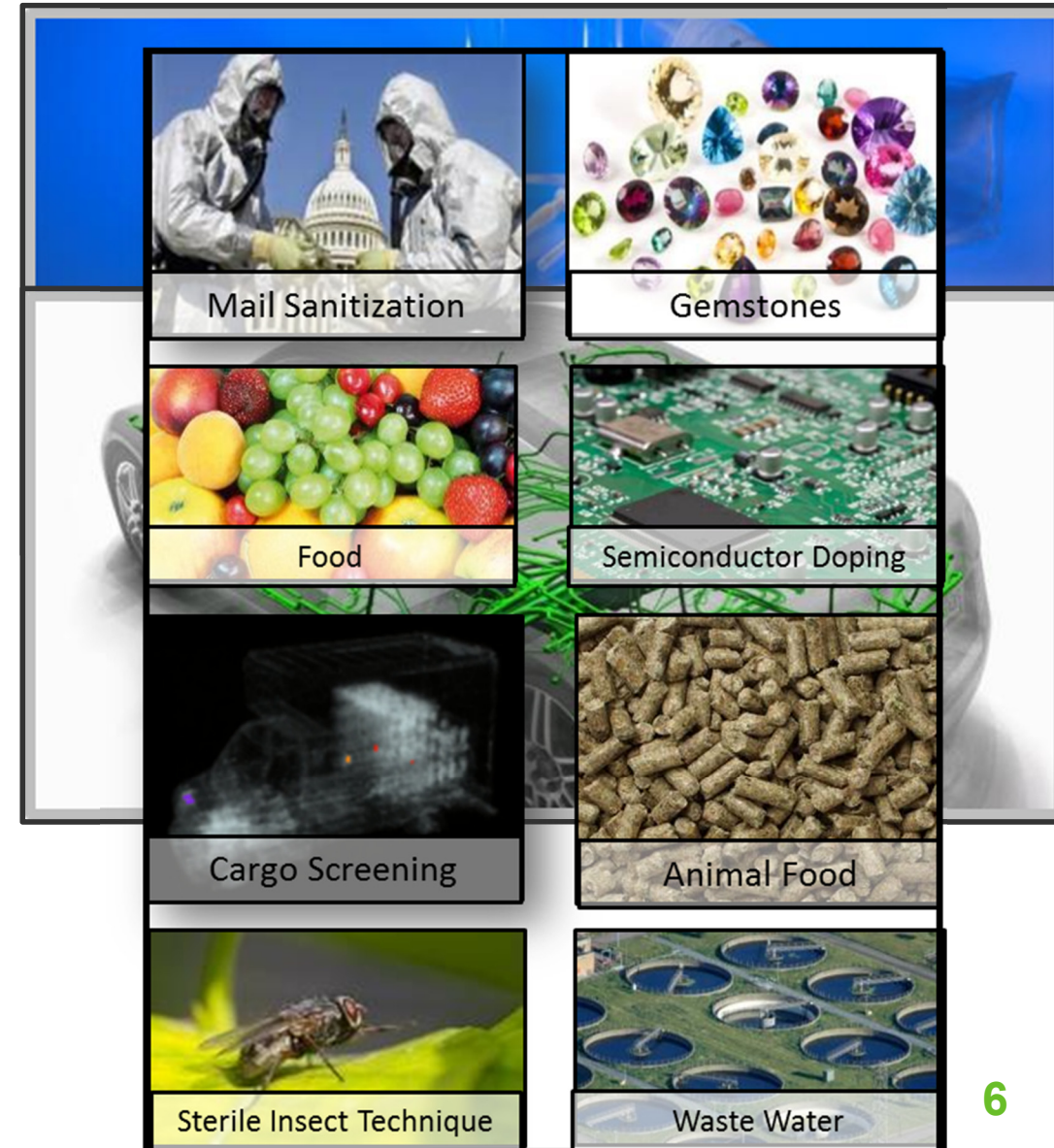

Rhodotron principle

- Coaxial cavity in TEM mode
⇒ radial RF electric field in the median plane, from outer conductor (cavity wall) to inner conductor (pillar)



Rhodotron principle

- Coaxial cavity in TEM mode
⇒ radial RF electric field in the median plane, from outer conductor (cavity wall) to inner conductor (pillar)
- Outside egun injecting radially
- Accelerating twice on one pass through the cavity ⇒ E-field changes direction during pillar transit



Rhodotron principle

- Coaxial cavity in TEM mode \Rightarrow radial RF electric field in the median plane, from outer conductor (cavity wall) to inner conductor (pillar)
- Outside egun injecting radially
- Accelerating twice on one pass through the cavity \Rightarrow E-field changes direction during pillar transit
- Re-injection after each pass via external dipoles \Rightarrow E-field changes direction during dipole transit

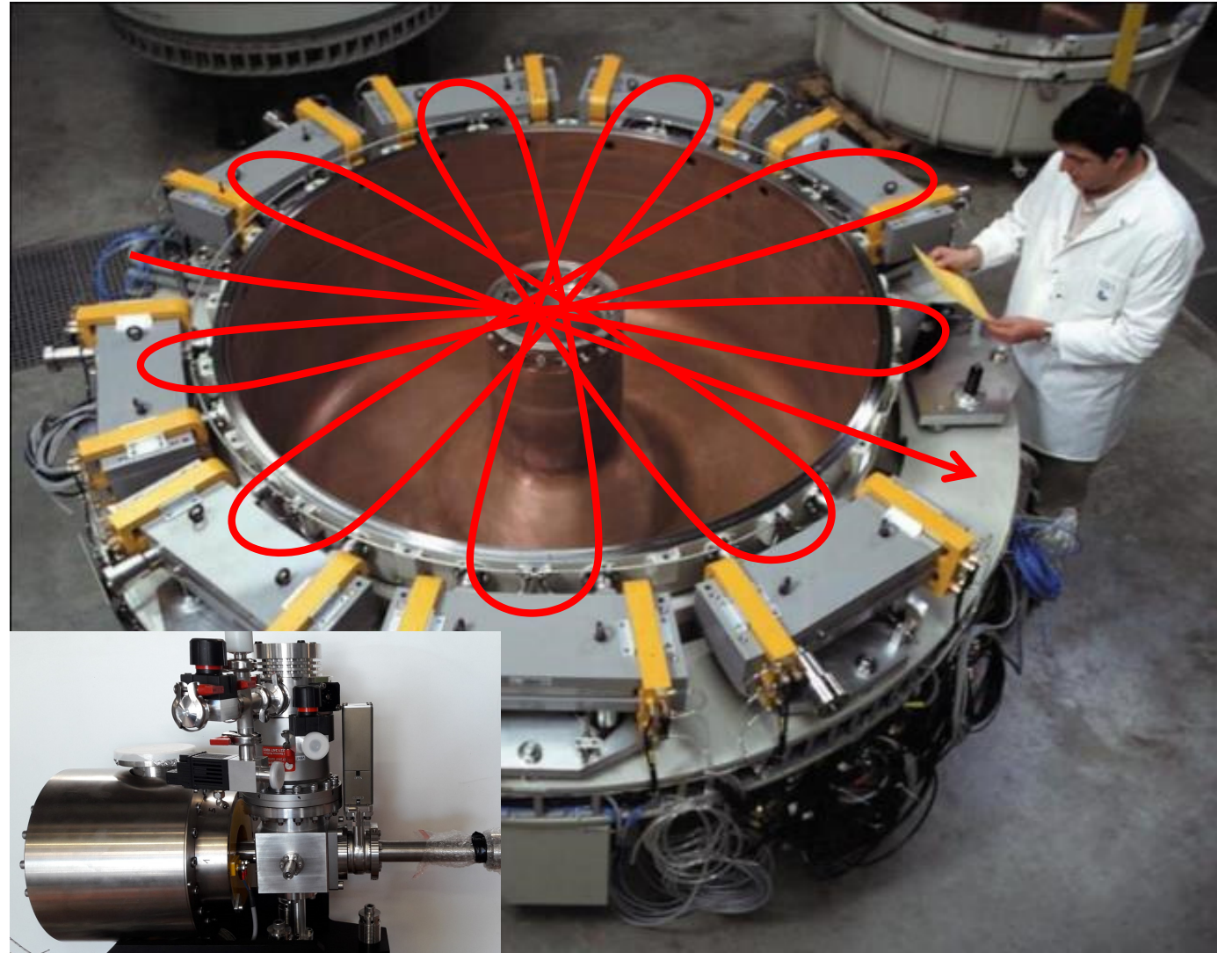

A typical facility layout

- Boxes to be irradiated are placed on a conveyor and moved through the beam area of the rhodotron which is installed one level up
- The e-beam is spread out over $\sim 1\text{m}$ width by scanning magnets



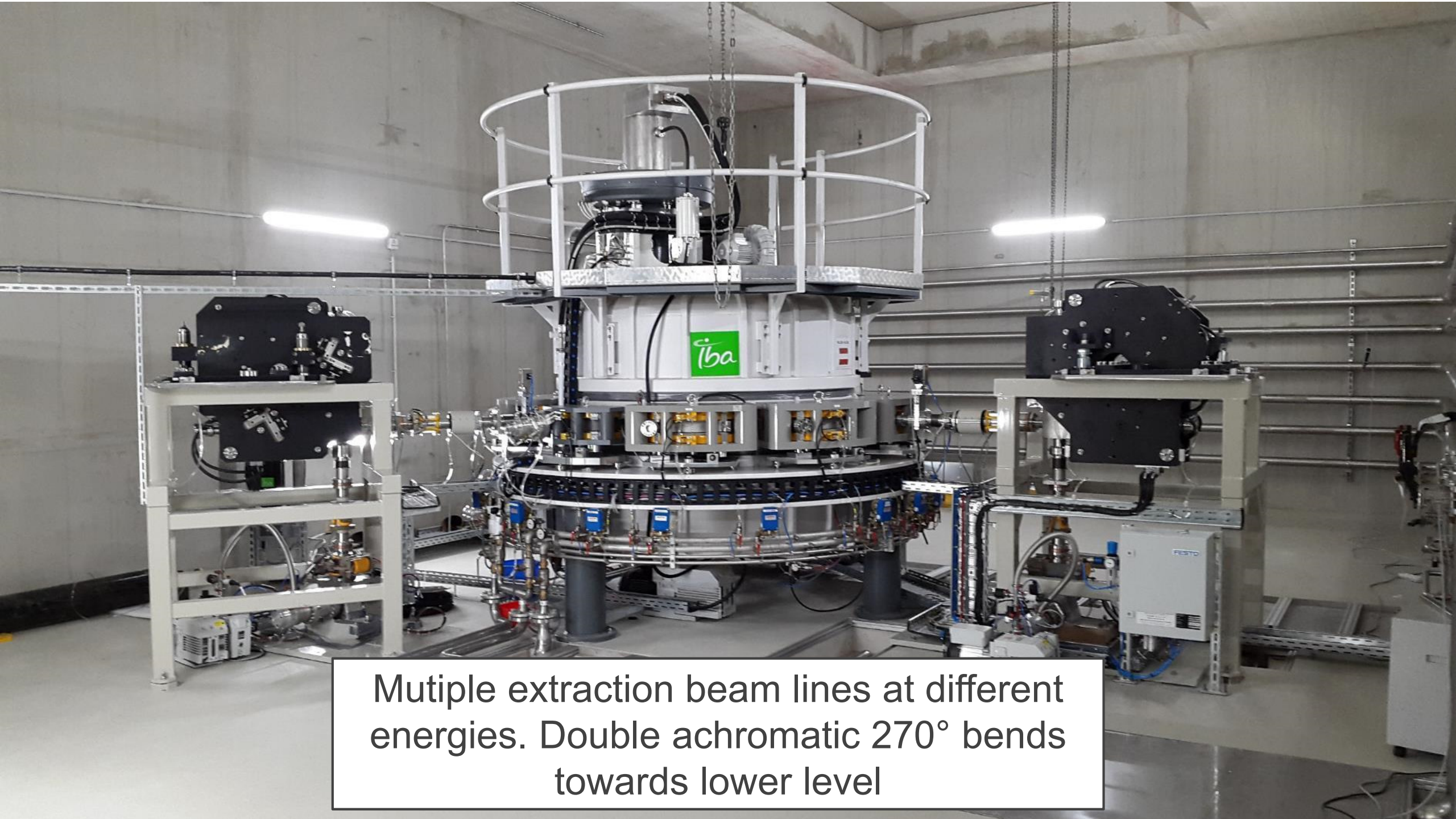

Mutiple extraction beam lines at different energies. Double achromatic 270° bends towards lower level

A simple model for linear transverse optics (1)

- The model calculates hard-edge linear optics along one period (optical cell) of the turn-pattern
- A half cell consists of a drift l , a pole face rotation β and a uniform bend (angle $\pi + 2\gamma$)
- The pole face rotation depends on the fringe field shape by an integral k_1
- The betatron phase advance per cell Φ is obtained from the trace of the full period transfer matrix:

$$\cos \Phi = \frac{1}{2} \text{Trace}(M)$$

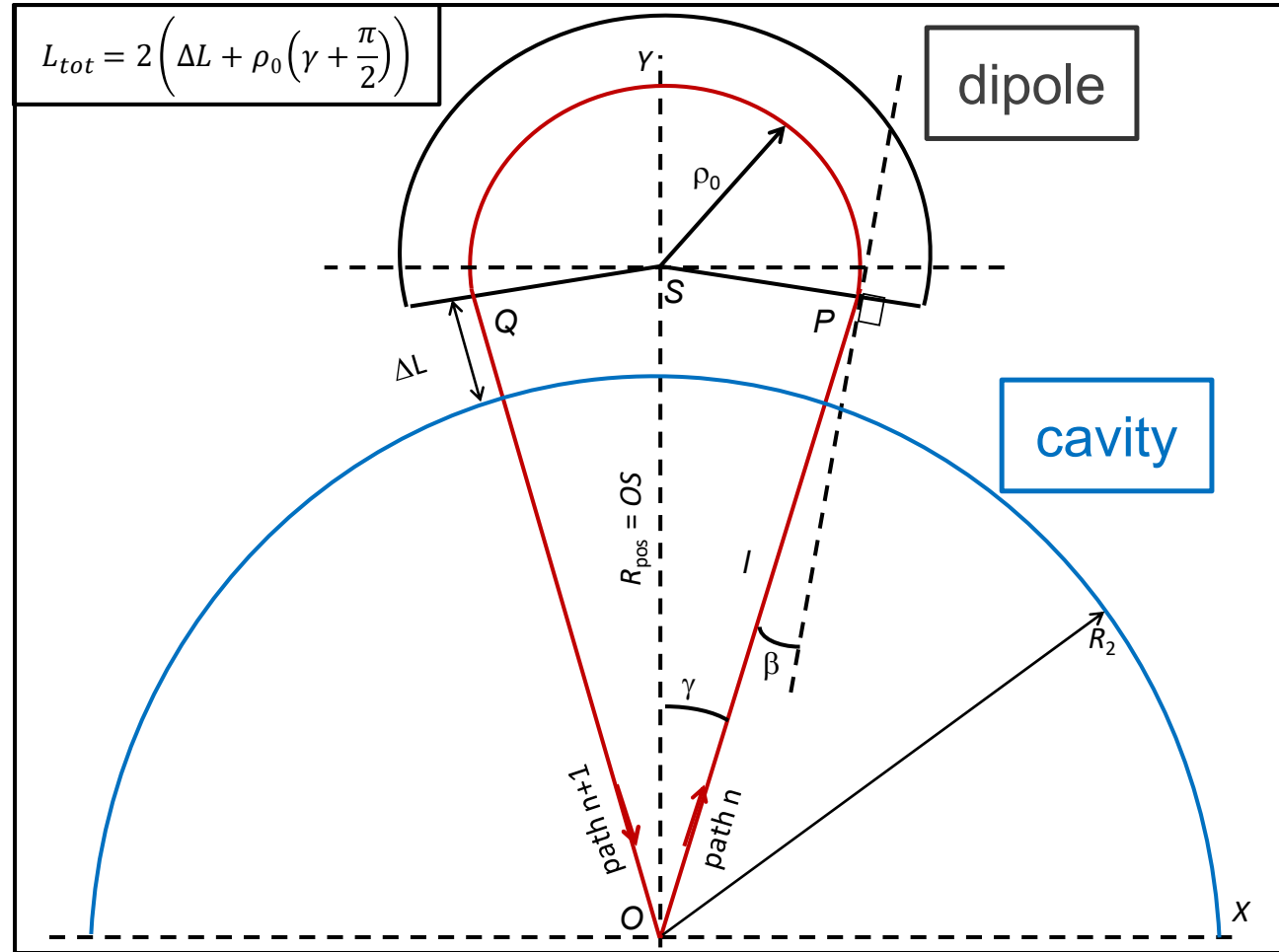

A simple model for linear transverse optics (2)

- Best stability is obtained for $\Phi_x \approx \Phi_z$ and small values of k_1 .
- Dipole field clamps are used to obtain this condition

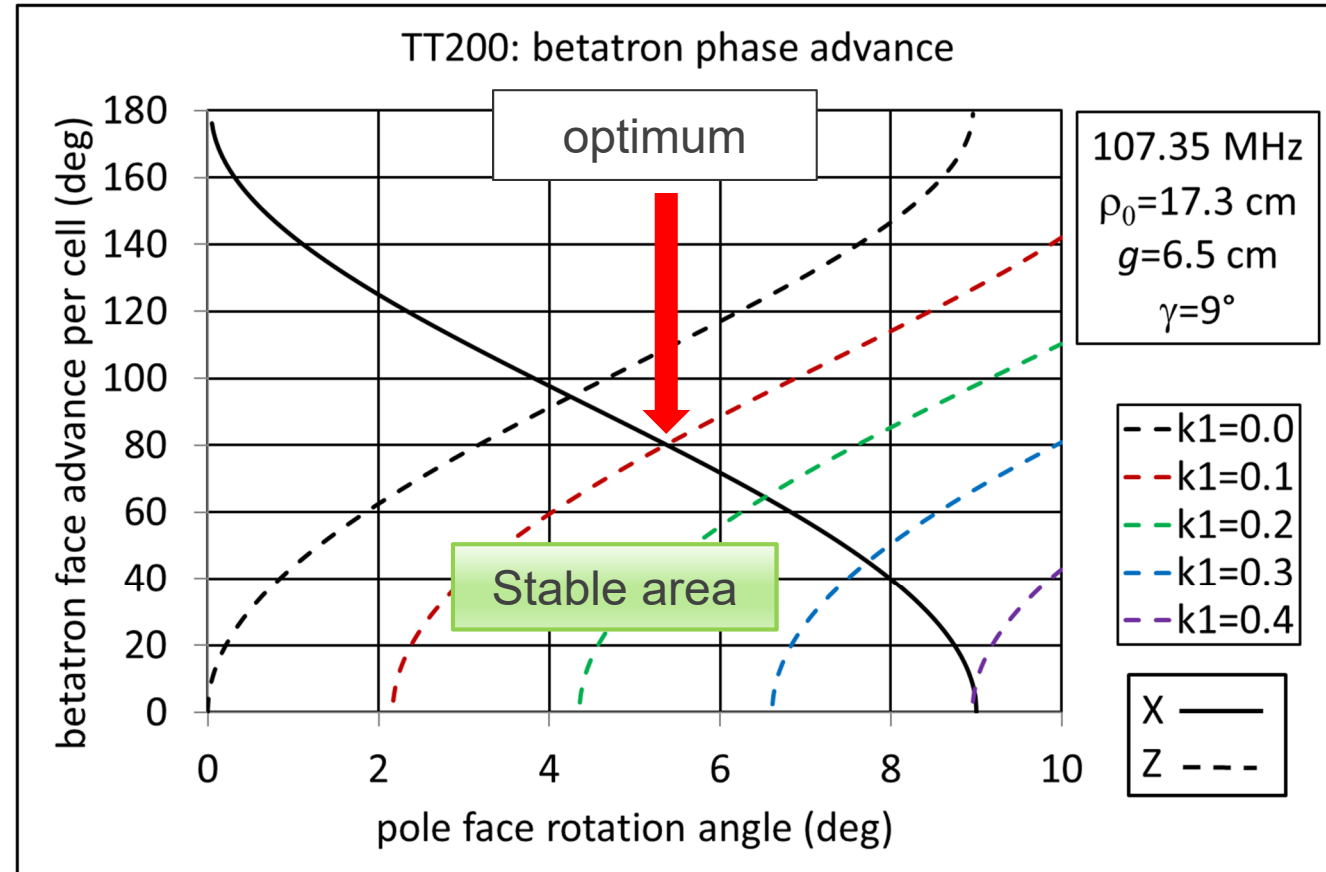
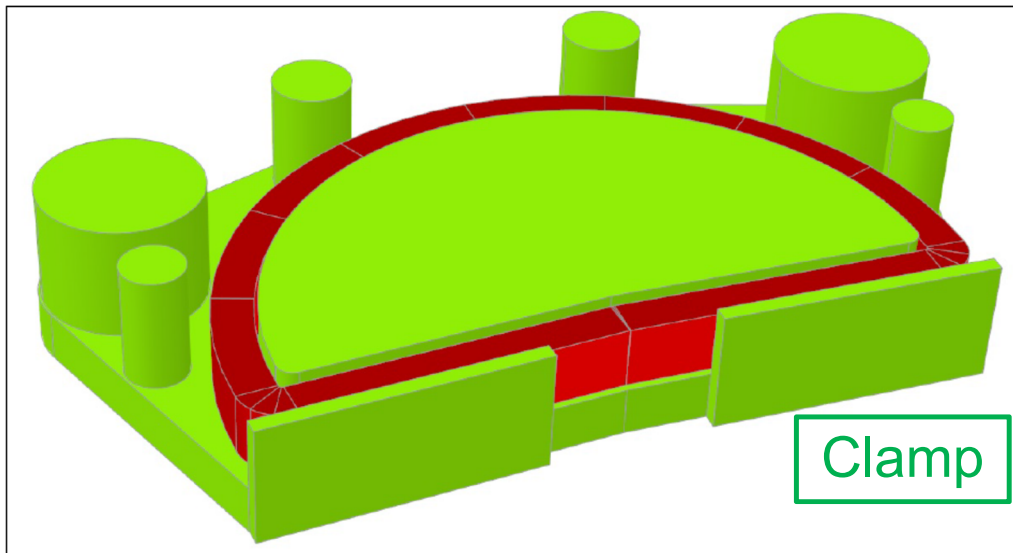

A simple model for linear transverse optics (2)

- Best stability is obtained for $\Phi_x \approx \Phi_z$ and small values of k_1 .
- Dipole field clamps are used to obtain this condition

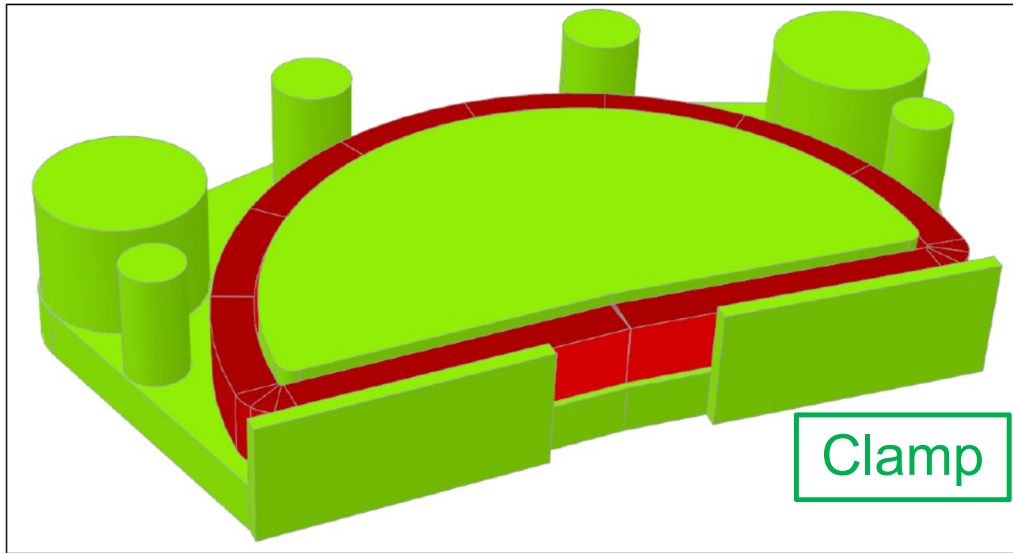

- Tracking code AOC confirms sensitive dependence of beam-envelopes on pole face angle .

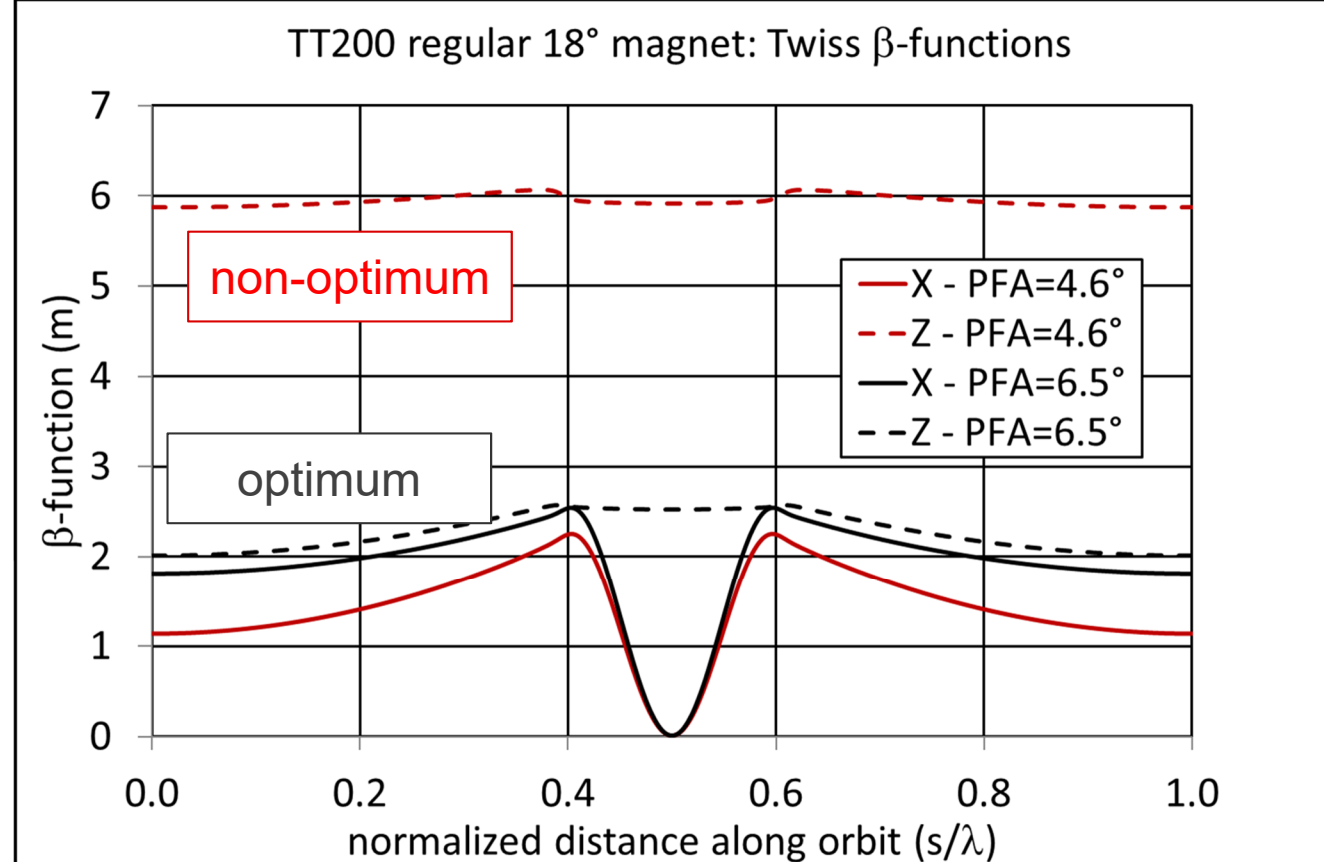
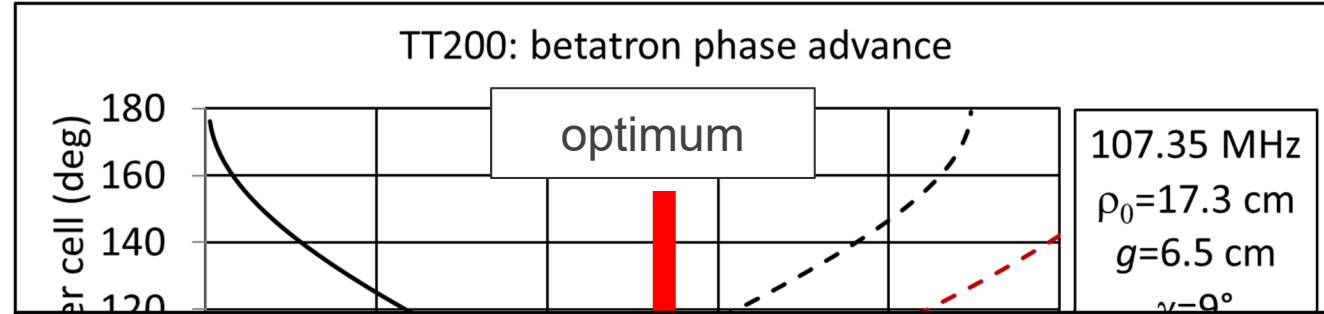

A simple hard-edge model for longitudinal optics (1)

- Cavity oscillates in almost perfect TEM-mode
- Electric field in median plane is radial and shows a $1/r$ dependence

$$E_r(r) = V_0 / r \ln\left(\frac{R_2}{R_1}\right)$$

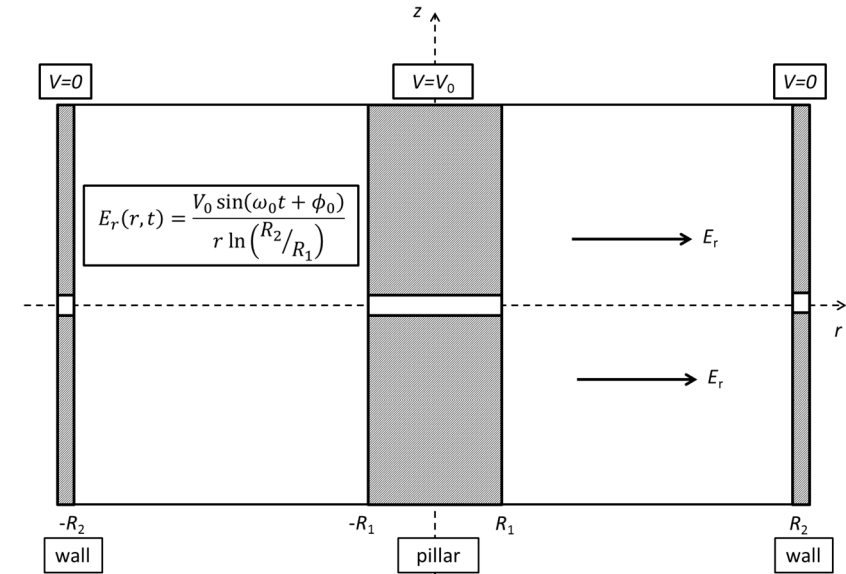

Radial electric field along injection axis

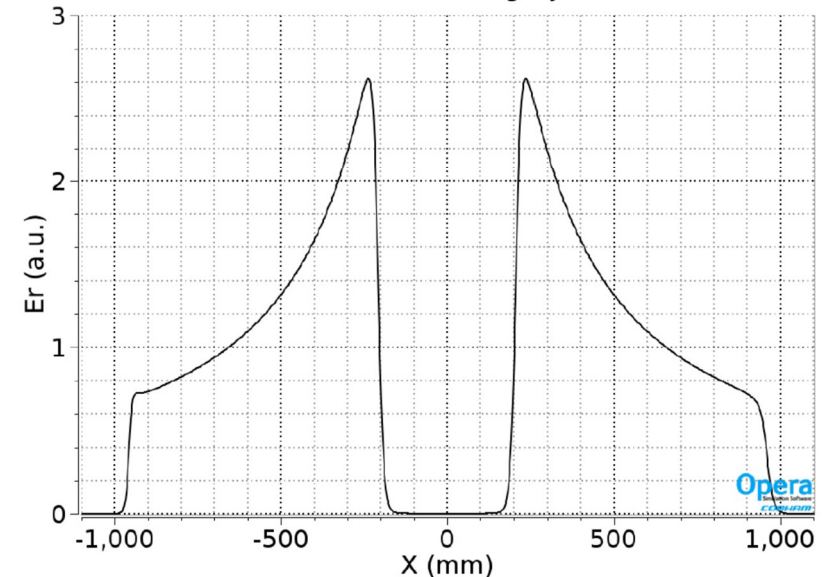

A simple hard-edge model for longitudinal optics (1)

- Cavity oscillates in almost perfect TEM-mode
- Electric field in median plane is radial and shows a $1/r$ dependence

$$E_r(r) = V_0 / r \ln\left(\frac{R_2}{R_1}\right)$$

- Equation of motion through a pass have been implemented in Excel
- Model calculates subsequent passes:
 - cavity \Rightarrow tracking
 - Magnets \Rightarrow transit time from geometry

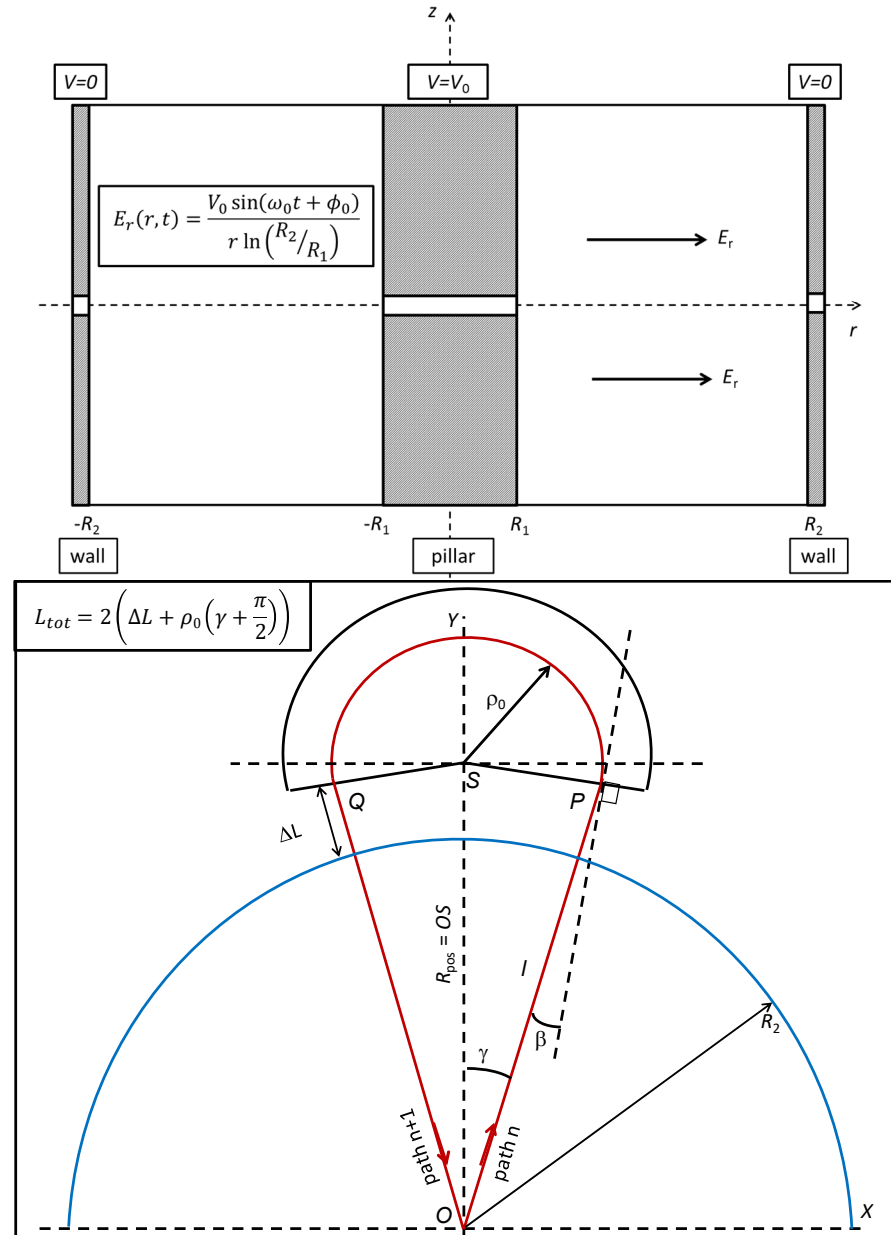

A simple hard-edge model for longitudinal optics (2)

- Step 1: calculate 'ideal' particle (gains max. energy). Done by optimizing (Excel solver):
 1. injection phase for first pass
 2. Orbit length through dipoles for each pass
 - This step gives positions, bend radius and fields (PSU-settings) of all magnets
- Step 2: allow dipoles to be shifted away from initial position:
 - Bend radius and PSU settings are accordingly adopted
- Step 3: allow a range of injection phases:
 - transit times through dipoles are accordingly adopted

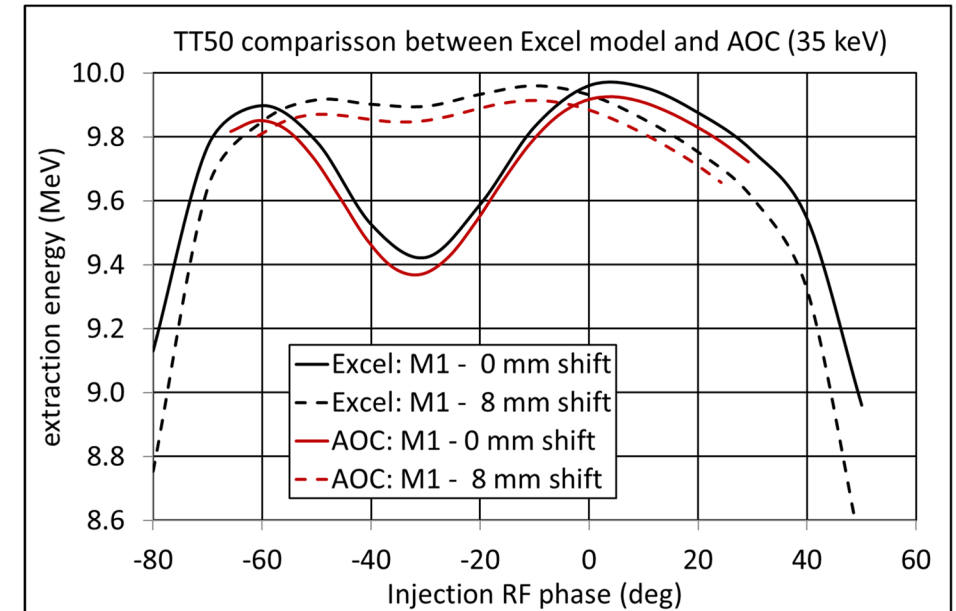

- Extraction energy as function of injection phase
- Good agreement between Excel and tracking code AOC
- Repositioning of M1 gives improved energy spectrum

A simple hard-edge model for longitudinal optics (2)

- Step 1: calculate 'ideal' particle (gains max. energy). Done by optimizing (Excel solver):
 1. injection phase for first pass
 2. Orbit length through dipoles for each pass
 - This step gives positions, bend radius and fields (PSU-settings) of all magnets
- Step 2: allow dipoles to be shifted away from initial position:
 - Bend radius and PSU settings are accordingly adopted
- Step 3: allow a range of injection phases:
 - transit times through dipoles are accordingly adopted

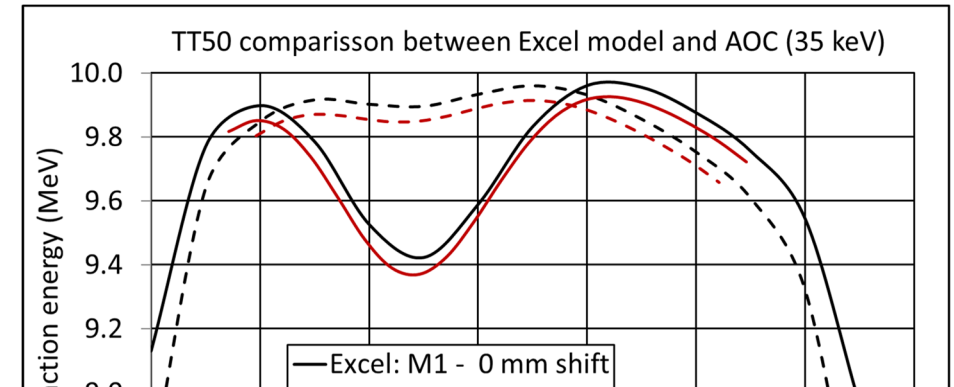

Improved energy spectrum at extraction confirmed by full 3D tracking code AOC

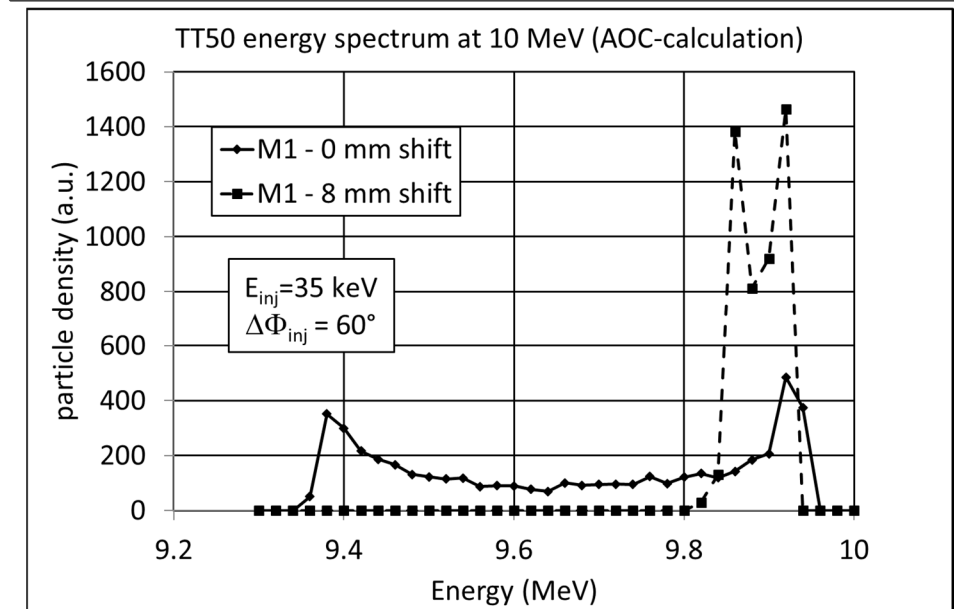

RF cavity fields computations for particle tracking

- Since the cavity oscillates in almost perfect TEM-mode, it can be solved electrostatically
- We use the electrostatic solver Opera3D to generate full 3D maps close to the median plane for particle tracking
- It allows to use fine meshing in critical zones such as beam holes where transverse electrical focusing can be strong
- Vacuum chambers are included in the model, in order to be able to detect possible particle losses everywhere
- RF magnetic field is obtained via relation with the electric field

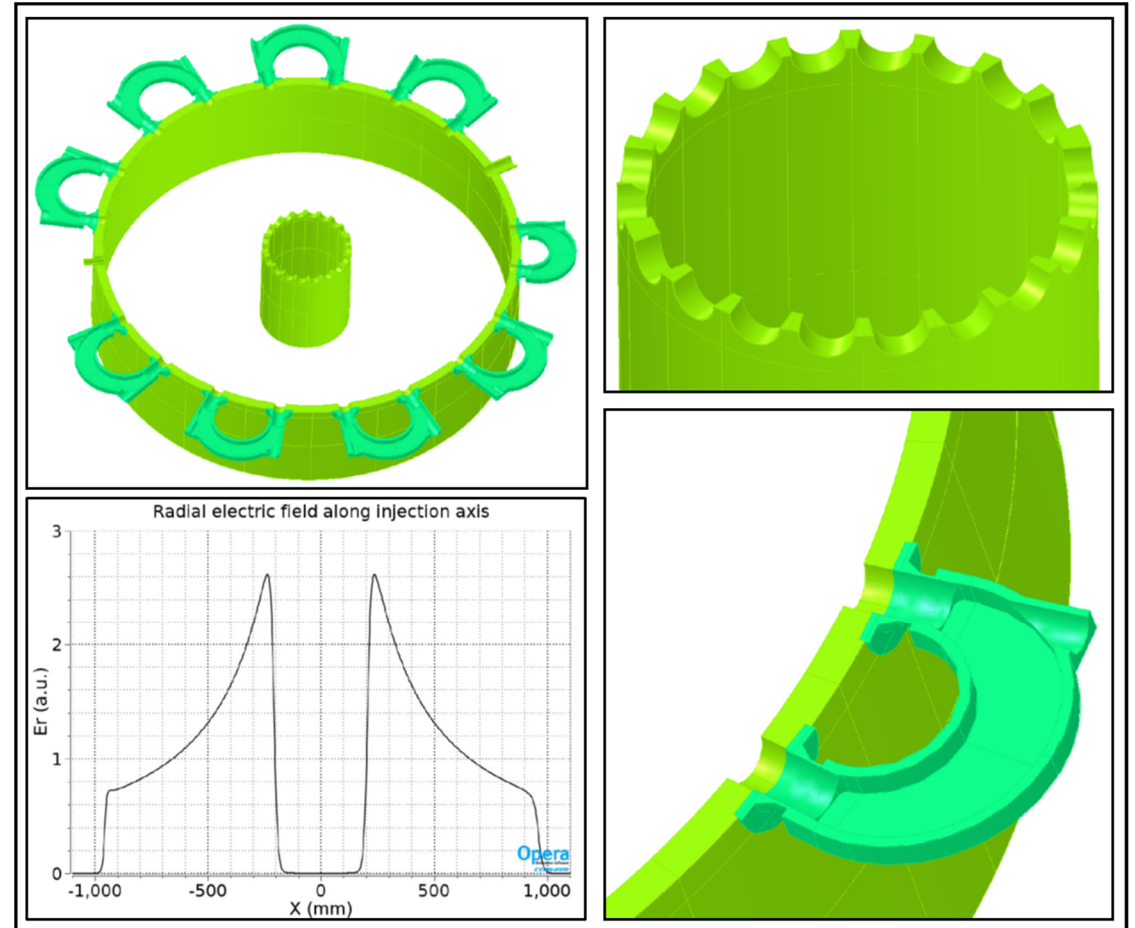

$$E_r = E_{r0} \sin \omega t$$
$$B_\theta = \frac{E_{r0}}{\eta_0} \tan(\omega z/c) \cos \omega t$$

3D magnetic field computations for particle tracking

- Opera3D is used to generate full 3D maps of all different magnets (dipoles, egun solenoids,...), which can be included in AOC
- Maps can be placed with 6 degrees of freedom and individually scaled according to PSU setting
- In regions where maps overlap, one can choose to accumulate fields, or to include only the most relevant magnet
- In this way, the full Rhodotron magnetic structure can be constructed and tuned for optimum beam transmission
- **Low energy electrons maybe very sensitive to stray magnetic fields.**

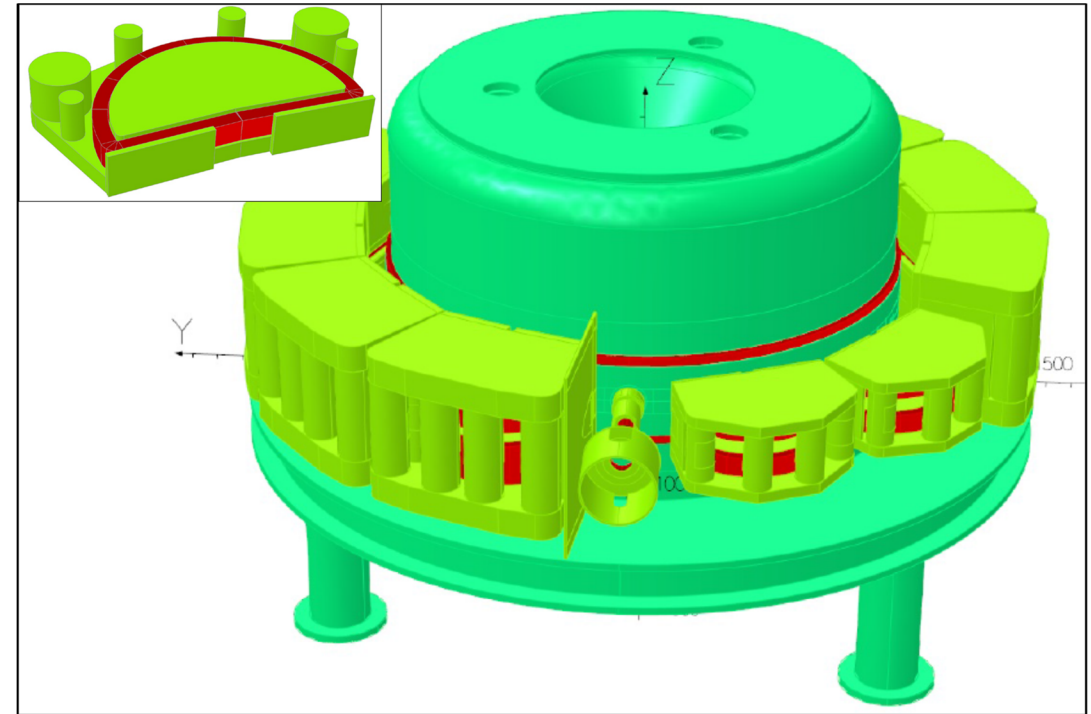

Pulsed 40 MeV rhodotron under study for isotope production by photo-nuclear reaction

3D magnetic field computations for particle tracking

- Opera3D is used to generate full 3D maps of all different magnets (dipoles, egun solenoids,...), which can be included in AOC
- Maps can be placed with 6 degrees of freedom and individually scaled according to PSU setting
- In regions where maps overlap, one can choose to accumulate fields, or to include only the most relevant magnet
- In this way, the full Rhodotron magnetic structure can be constructed and tuned for optimum beam transmission
- **Low energy electrons maybe very sensitive to stray magnetic fields.**
- To account for this, we construct a full model with all magnets and all (iron) subsystems (support structure, cavity, egun shield...) and construct a cross-talk map that represents the difference between the full structure and the sum of the separate magnets.
- A pair of global solenoids around the cavity allows to globally fine-tune the first pass

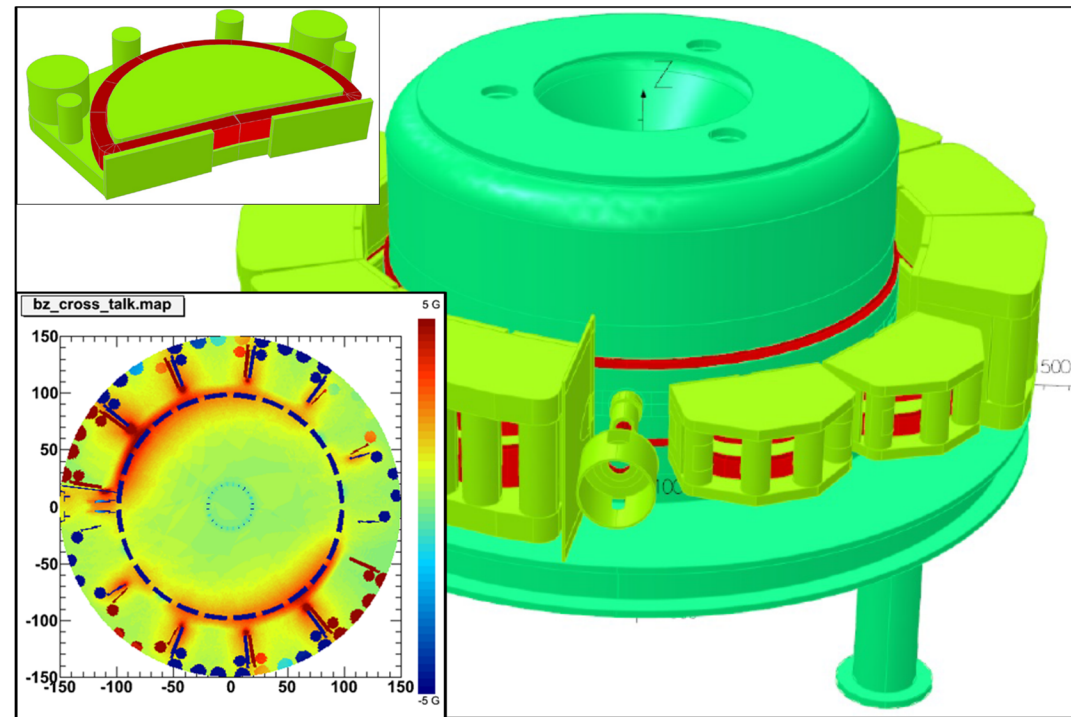

Pulsed 40 MeV rhodotron under study for isotope production by photo-nuclear reaction

Full 3D particle tracking with space charge

- The tracking code AOC calculates the full 3D electric and magnetic self-fields of the bunch
 - Relativistic particle-to-particle calculation
 - Any bunch-shape allowed
- These effects are important at high intensities and especially at lower energies (within the egun and during the first pass)
- The figure shows a space charge beam in the TT50 for a 10 mA average peak current (roughly 100 mA bunch current)
- Beam is simulated from egun cathode (35 keV) upto extraction at 10 MeV

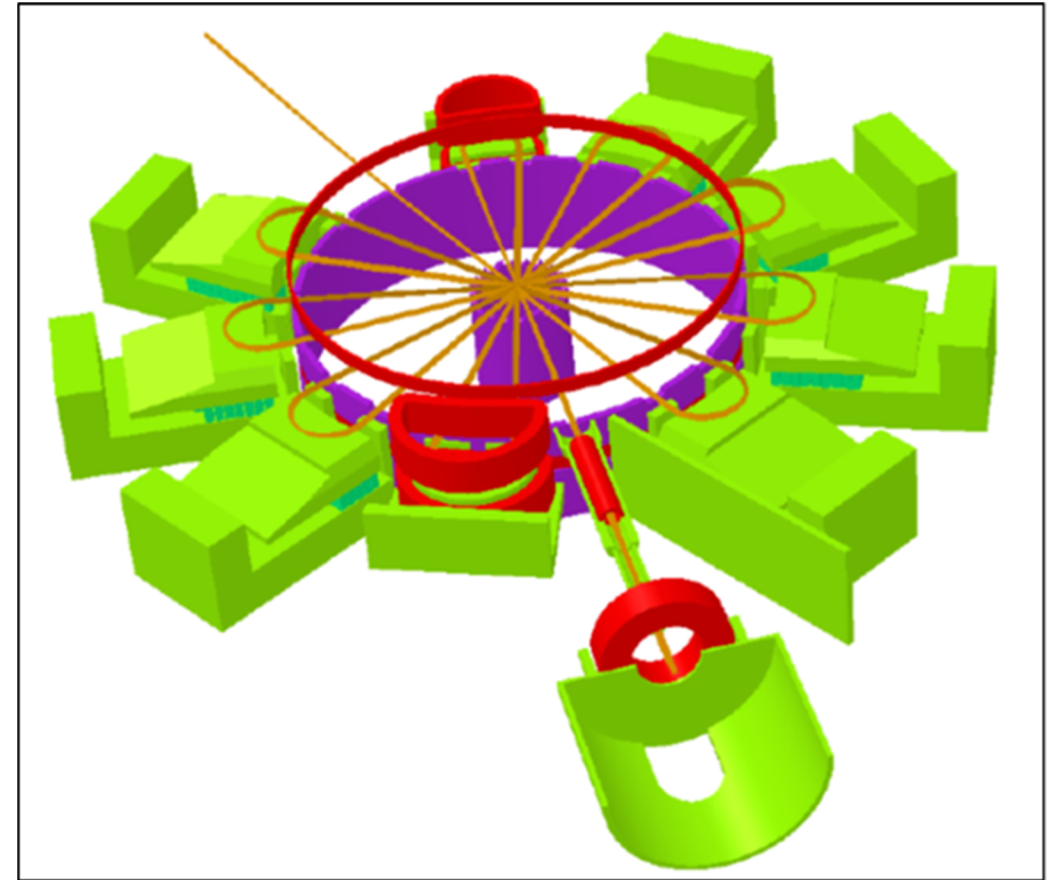

Compact TT50 \Rightarrow pulsed 10 MeV machine, newly developed for container security scanning. It uses permanent magnet dipoles

- A rotational symmetric model of the egun is solved with the Opera2D space charge module (SP)
- The model contains the cathode (with holder) at high negative voltage, a beam extraction electrode (ground), a bias electrode (preventing cathode back-bombardment by ions), a focusing solenoid and an iron shield screening external magnetic stray fields
- The model is solved, first in magnetic mode and then in self-consistent electric space charge mode (The cathode surface is a Child-Langmuir emitter)
- The cathode grid is simulated as a series of concentric circular wires. The cathode-grid voltage determines the extracted current
- The SP solver calculates self-consistent beamlets that leave the cathode and pass through the grid
- The model is solved for a number of cathode-grid-voltages; this allows to construct a realistic 6D phase space of the RF bunch, needed for tracking

Egun simulations

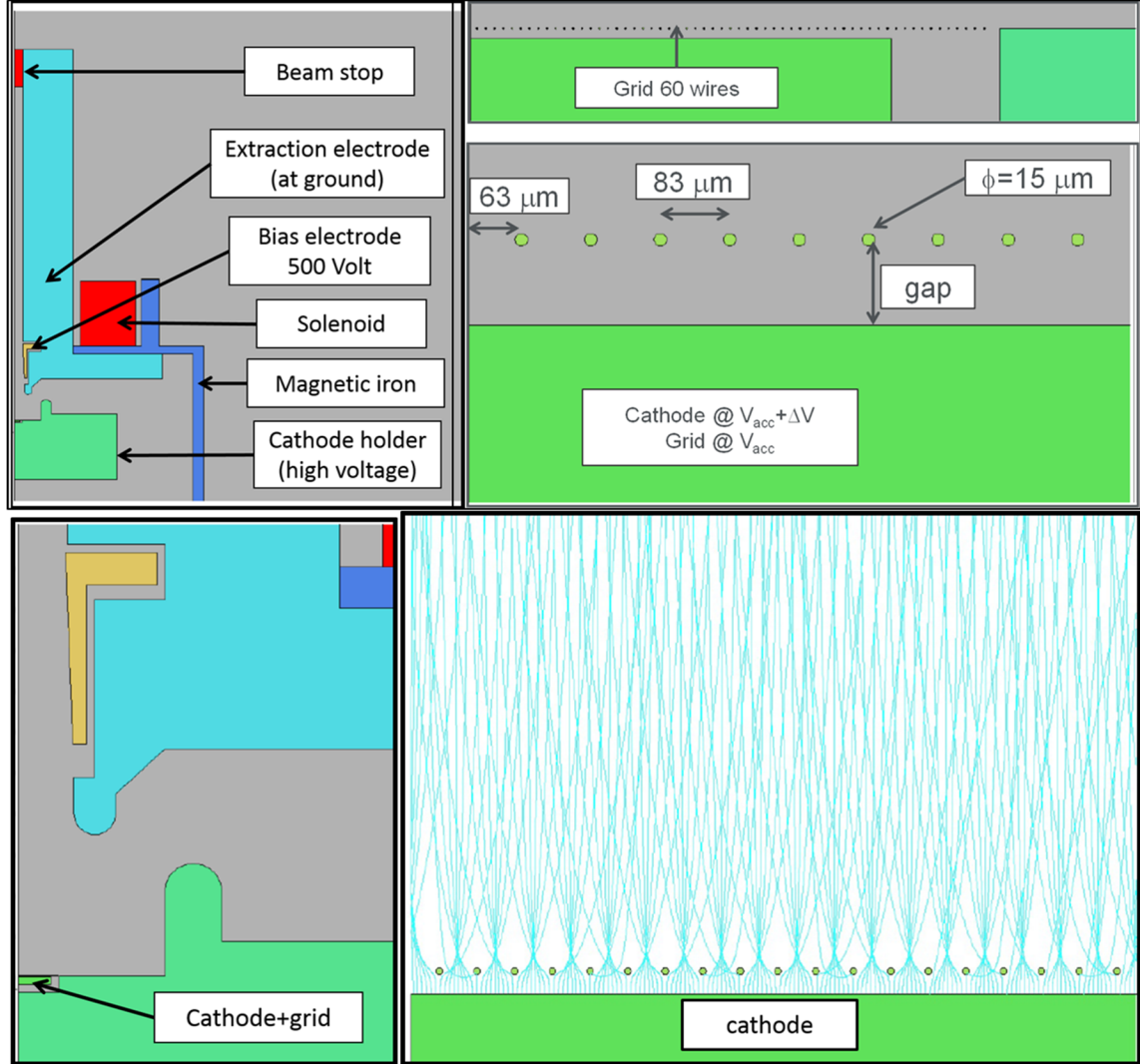

Conclusion

- The tools described, allow to make fast and simple conceptual design studies
- But also to do very detailed beam tracking studies that include:
 - 3D cavity RF field maps and 3D static magnetic field maps
 - Effects of magnetic stray fields and mutual interaction of magnets
 - Perturbations due to iron support structures and earth magnetic fields
 - Full self-consistent space charge effects
 - Self-consistent beams from the egun
- This tracking simulates the full accelerator from the source up to extraction
- These tools have allowed to successfully construct and commission the TT50: the latest member of the Rhodotron family, using pulsed RF and permanent magnet technology
- Acceleration of 3.5 MeV per pass has been demonstrated at the company, paving the road for the 40 MeV machine, to be used for isotope production

PROTECT +
ENHANCE +
SAVE LIVES



Thank you for your attention

Wiel Kleeven

INDUSTRIAL &
STERILIZATION
SOLUTIONS

