

# HIGH POWER BEAM OPERATION OF THE J-PARC RCS AND MR

Yoichi Sato for J-PARC Accelerator Group

May 3<sup>rd</sup>, 2018

THYGBF1, IPAC2018

# Contents

- Overview
- RCS
  - 1 MW beam test
  - Compatibility of both MLF and Main Ring operations
- MR with fast extraction
  - Typical operation and basic tuning keys
  - Study for upgrade plan
- MR with slow extraction
- Summary

Japan  
Proton  
Accelerator  
Research  
Complex  
Complex  
(J-PARC)

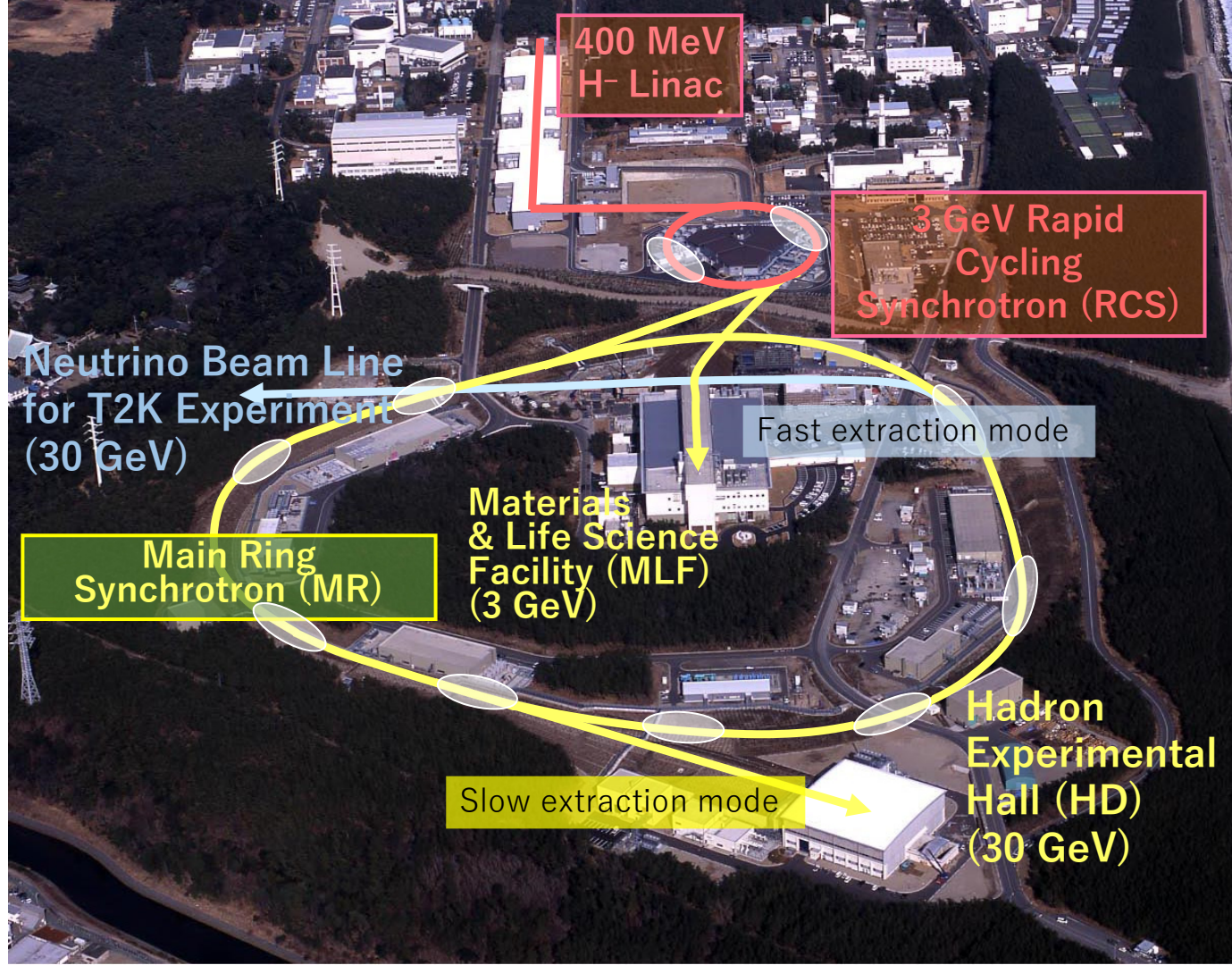

## Beam Power History RCS to MLF

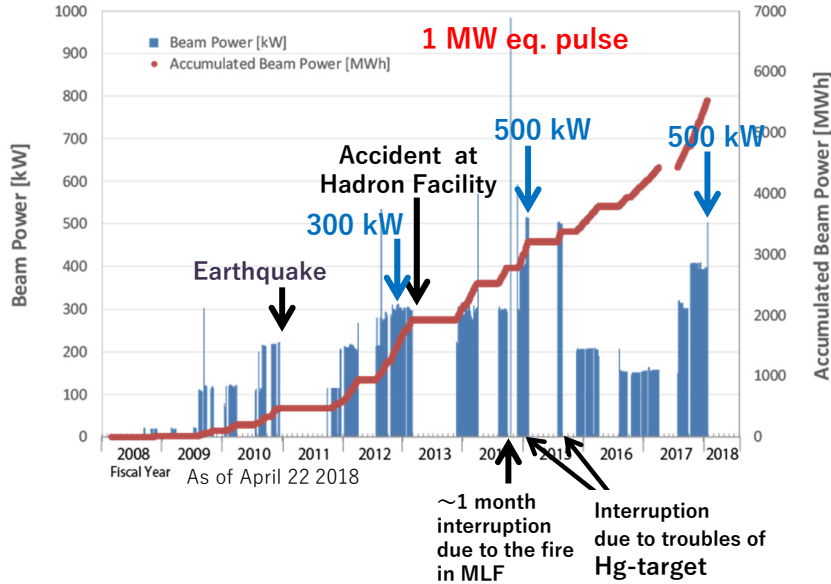

- Beam power has steadily increased.
- Stable user operation:  
MLF 500 kW  
NU 490 kW  
HD 50 kW

## Beam Power History MR to NU (FX) / HD (SX)

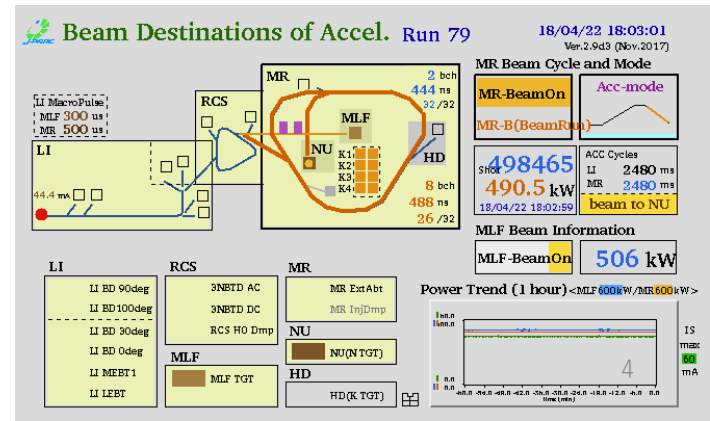
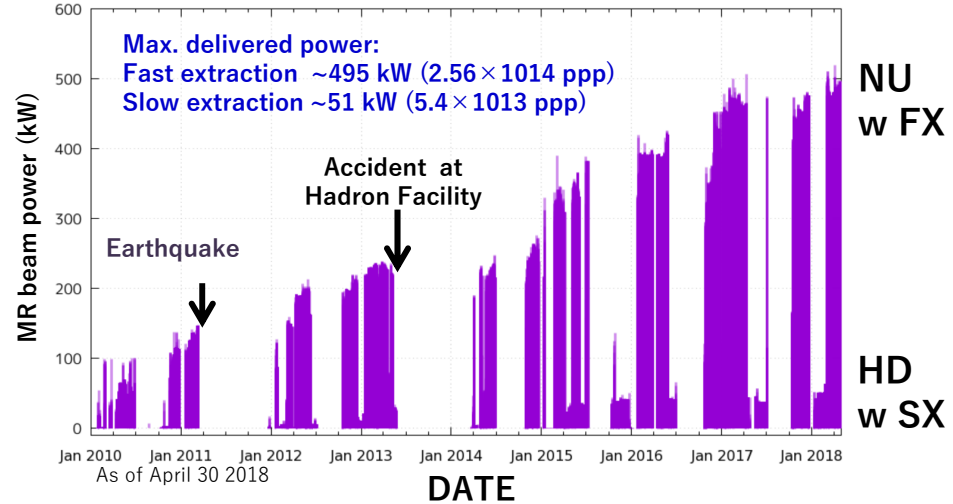

# RCS (Rapid cycle synchrotron)

- 1 MW beam test
- Compatibility of both MLF and Main Ring operations

# 1-MW beam (designed beam power) test in 2016

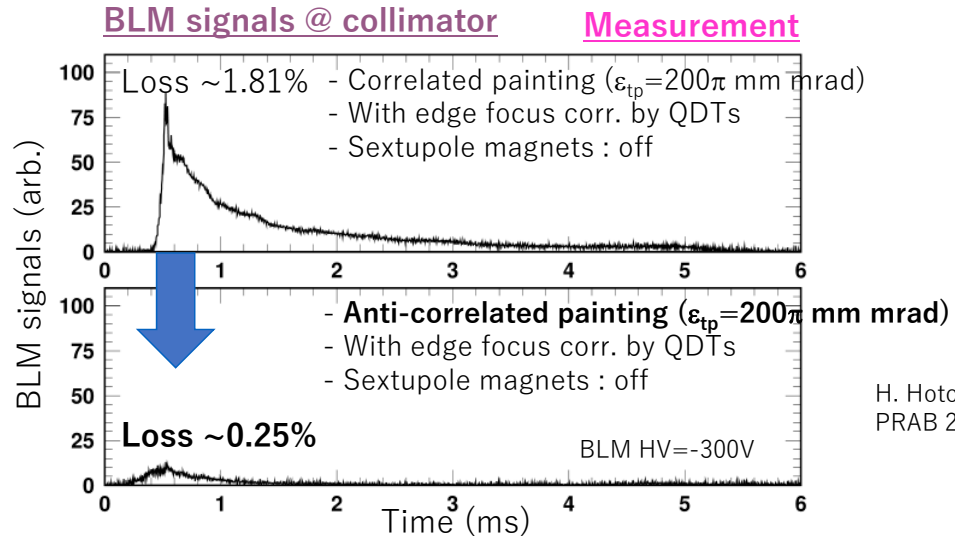
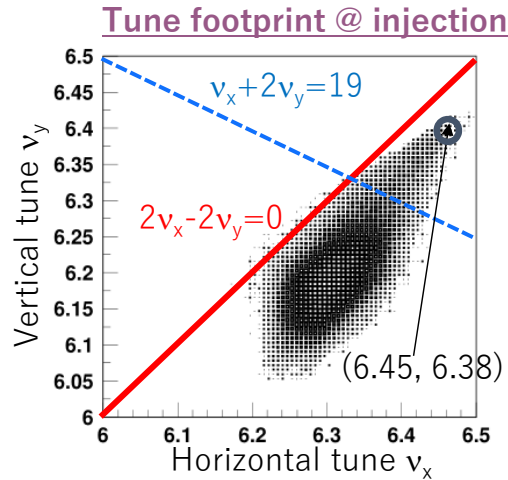

H. Hotchi et al.,  
PRAB 20, 060402 (2017)

- Issues in realizing a large transverse painting were  $v_x + 2v_y = 19$  and  $2v_x - 2v_y = 0$ ; they cause a shrinkage of the dynamic aperture and make additional beam loss when the transverse painting area is enlarged to  $\epsilon_{tp} > 100\pi$  mm mrad.
- By minimizing the effects of  $v_x + 2v_y = 19$  and  $2v_x - 2v_y = 0$ , the transverse painting area was successfully expanded to  $200\pi$  mm mrad.

H. Hotchi et al., PRSEAB 15, 040402 (2012)  
PRAB 19, 010401 (2016)

- We achieved a 1-MW beam acceleration with a very small beam loss of a couple of  $10^{-3}$ .**

Loss:  $\sim 0.25\%$  at  $\sim 400$  MeV  $\Rightarrow 333$  W · · · Small, but not negligible for machine activations

- We tried **further** beam loss mitigation with better operation point

## Beam loss : (6.45, 6.38) vs (6.45, 6.32)

H. Hotchi et al.

- 40 mA, 500  $\mu$ s, 489 ns, 2 bunches;  
~ $7.70 \times 10^{13}$  ppp (~924 kW-eq.)
- Transverse painting;  
 $\varepsilon_{tp}=200\pi$  mm mrad
- Full longitudinal painting

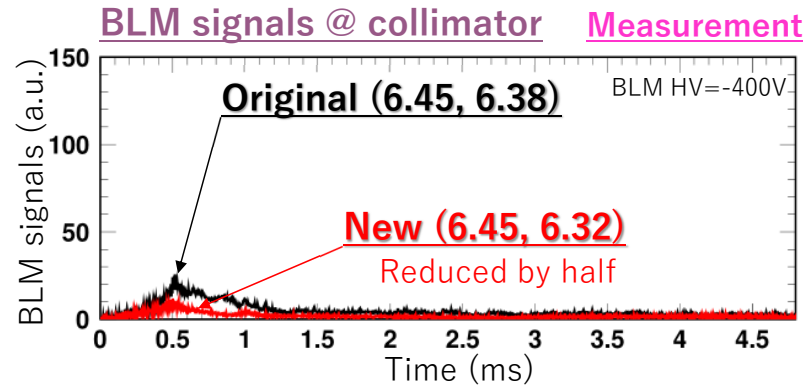
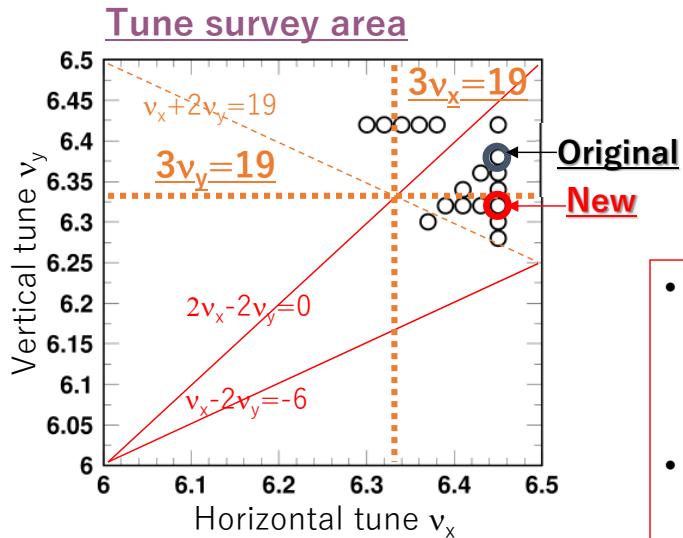

- **Through the experiment and the simulation study, we got a new operating point:** more suitable for the beam operation **to MLF**, which requires  $200\pi$  mm mrad painting
- **New operating point (6.45, 6.32)**, avoids the effect of  $3v_y=19$ , and also keeps the less effect of  $3v_x=19$ .
- **The beam loss was well reduced 1/2.**

# FOR MR: Emittance growth and cause

## Tune diagram

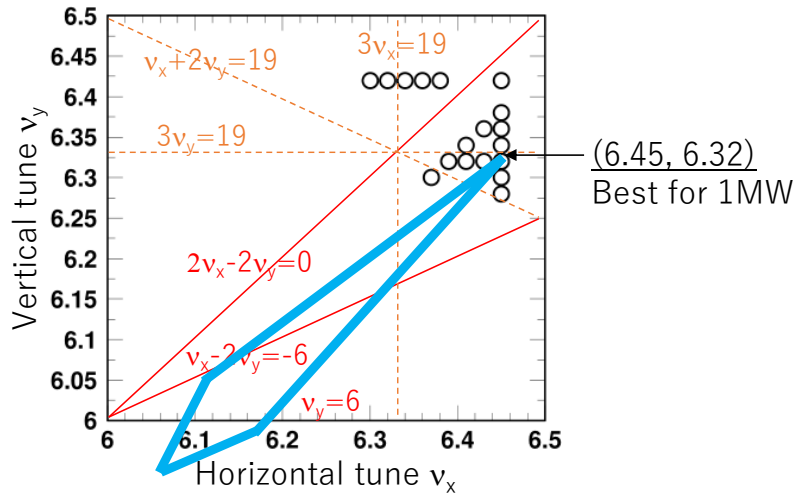

Main cause of the emittance growth :  $v_y=6$

## Time dependence of beam emittance simulated

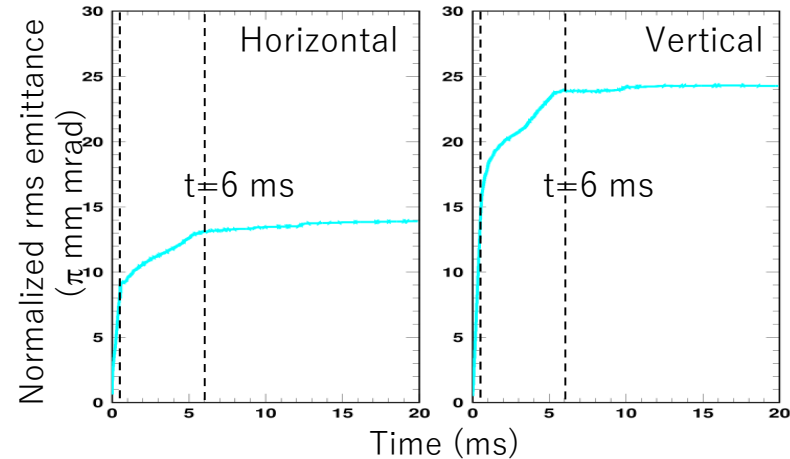

Significant emittance growth occurs for the first 6 ms, especially on the vertical plane.

- **Low emittance beam required in MR**, because its physical aperture is much smaller than the MLF.
- **Small injection painting emittance is adopted:  $\varepsilon_{tp}=50\pi$  mm mrad**
  - ⇒ **A large space-charge detuning is generated.**
  - ⇒ **A part of beam particles reaches  $v_y=6$ :** all-order systematic resonance are excited, causing a large emittance growth especially on the vertical plane.
- **This emittance growth can be mitigated by manipulating the tune and the chromaticity so as to separate the beam from the integer.**

# Extracted beam emittances, manipulating tune and chromaticity

H. Hotchi, et al., TUPAL018, IPAC2018

- ID1 : -  $\varepsilon_{tp}=50\pi$  mm mrad  
- No chromatic corr.  
- Tune variation: (a)
- ID2 : -  $\varepsilon_{tp}=50\pi$  mm mrad  
- With chromaticity corr. (Bipolar excitation)  
- Tune variation: (a)
- ID3 : -  $\varepsilon_{tp}=50\pi$  mm mrad  
- With chromaticity corr. (Bipolar excitation)  
- Tune variation: (b)

- ID4: -  $\varepsilon_{tp}=50\pi$  mm mrad  
- With chromaticity corr. (Bipolar excitation)  
- Tune variation : (c) by adding 6 quadrupole-correctors

## Un-normalized rms emittance of the extraction beam

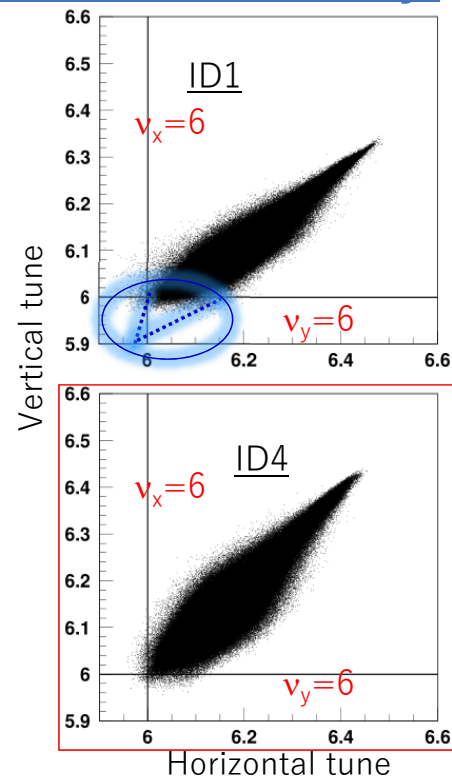
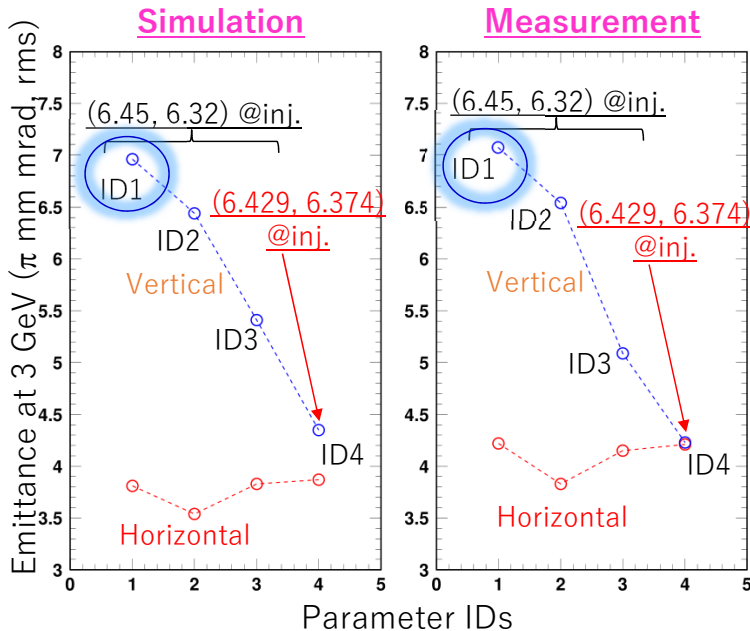

- Manipulating tune and chromaticity, the separation from  $v_y=6$  was well improved in ID4, and extracted beam emittance was well reduced, as predicted by simulation.
- Pulsed quadrupole correctors (QDTs) enabled additional tune change from ID3 to ID4.  
→ we can perform pulse by pulse switching of optimal tunes between MLF and MR

# Operational parameters optimized to date considering the compatibility of the beam operations to MLF & MR

H. Hotchi, et al., TUPAL018, IPAC2018

## To MLF:

- Tune @ injection:  $(6.45, 6.32)$
- Transverse painting:  $\varepsilon_{tp} = 200\pi$  mm mrad (anti-correlated/correlated)
- Sextupoles : off
- Full longitudinal painting

## **Pulse-by-pulse switching**

## To MR:

- Tune @ injection:  $(6.429, 6.374)$ , changed by pulsed quadrupole correctors (installed Summer 2017)
- Transverse painting:  $\varepsilon_{tp} = 50\pi$  mm mrad (correlated)
- Sextupoles : bipolar excitation
- Full longitudinal painting

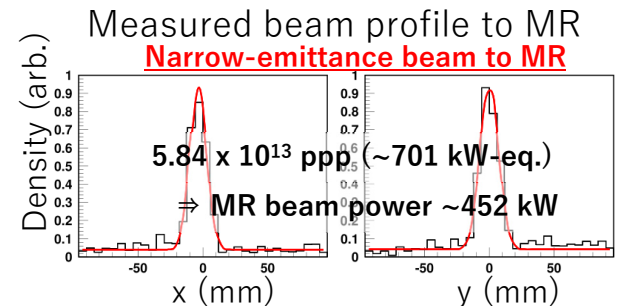
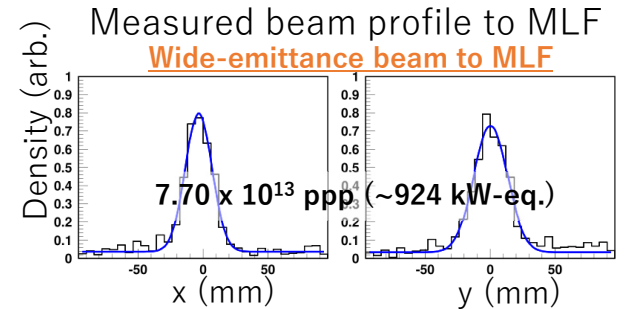

**By introducing a pulse-by-pulse switching of the tune, the painting area and the chromaticity, we successfully met different requirements from MLF and MR while keeping the RCS beam loss within acceptable levels.**

## Summary of RCS high intensity operation

- RCS has recently initiated a pulse-by-pulse switching of painting emittance, chromaticity and betatron tune. By this effort, we successfully met different requirements from MLF and MR while keeping beam loss within acceptable levels.
- Before the next summer maintenance, we will conduct a beam test with the design injection beam current of 50 mA, in which the feasibility of the design 1-MW beam operation to MLF and also its compatibility with the beam operation to MR will be inspected again with the new operational parameters optimized this time.

# Main Ring

- Overview
- With fast extraction for Neutrino Facility
- With slow extraction for Hadron Facility

# Main parameters of MR

Circumference	1567.5 m
Injection energy	3 GeV
Extraction energy	30 GeV
Super-periodicity	3
harmonic	9
Number of bunches	8
Rf frequency	1.67 - 1.72 MHz
Transition $\gamma$	j 31.7 (typical)

## Physical Aperture

3-50 BT Collimator	54-65 $\pi$ mmmrad	Capacity 2 kW
3-50 BT physical ap.	> 120 $\pi$ mmmrad	
Ring Collimator	54-70 $\pi$ mmmrad	Capacity 2 kW (JFY2017)
Ring physical ap.	> 81 $\pi$ mmmrad	

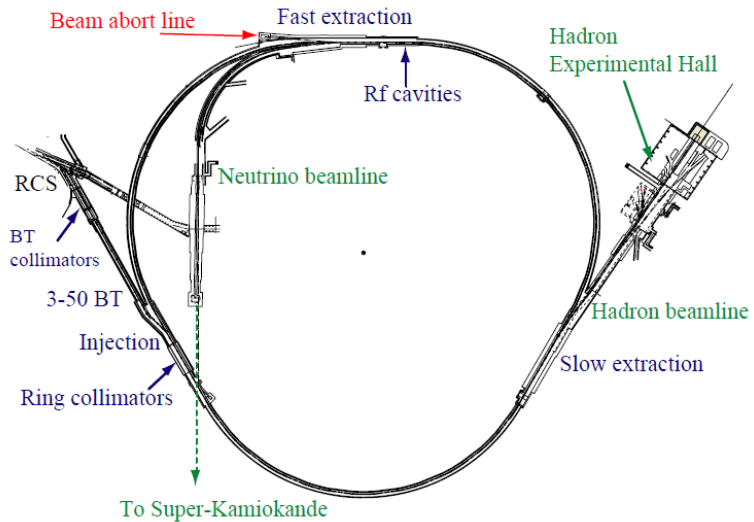

FX beam power  
0.75 MW (design)  
0.49 MW (present)

## Three dispersion free straight sections of 116-m long:

- Injection and collimator systems
- Slow extraction (SX) to Hadron experimental Hall
- RF cavities and Fast extraction (FX) (beam is extracted inside/outside of the ring)
  - outside: Beam abort line
  - inside: Neutrino beamline (intense  $\nu$  beam is send to SK)

# Main parameters of MR

<b>Circumference</b>	<b>1567.5 m</b>
<b>Injection energy</b>	<b>3 GeV</b>
<b>Extraction energy</b>	<b>30 GeV</b>
<b>Super-periodicity</b>	<b>3</b>
<b>harmonic</b>	<b>9</b>
<b>Number of bunches</b>	<b>8</b>
<b>Rf frequency</b>	<b>1.67 - 1.72 MHz</b>

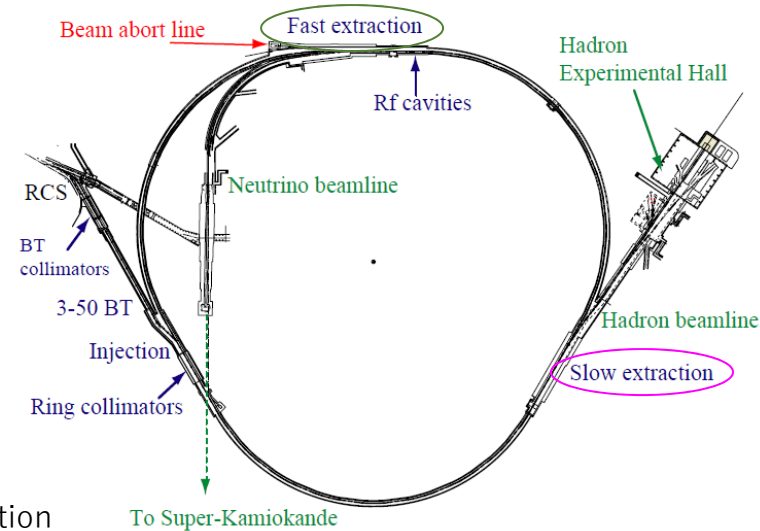

## TWO OPERATION MODES:

- **Fast extraction mode (FX)** for the neutrino experiment: 1 turn extraction
- **Slow extraction mode (SX)** for the hadron hall experiments: 2 s extraction

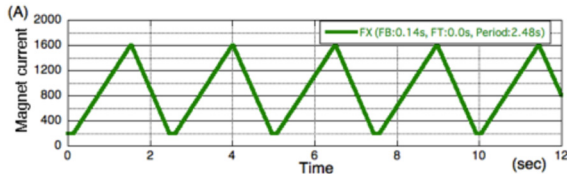

**FX Cycle time 2.48 s**

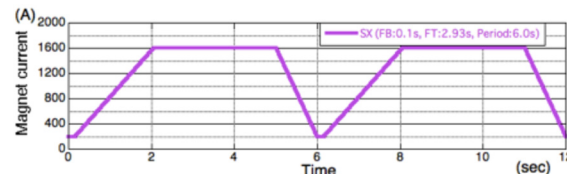

**SX Cycle time 5.52 s → 5.20 s**

**FX beam power**  
**0.75 MW (design)**  
**0.49 MW (present)**

### Beam power [W]

$$= \text{Ave. Beam Current [A=C/s]} \times \text{Beam Energy [eV]}$$

$$= \text{Number of charged particles [C/pulse]} \times \text{Number of pulse [pulse/s]} \times \text{Beam Energy [eV]}$$

Beam power is the most important parameter for our experiments.

# MR with fast extraction

- Typical operation and high intensity tuning keys

# Typical operation of MR 490 kW to NU

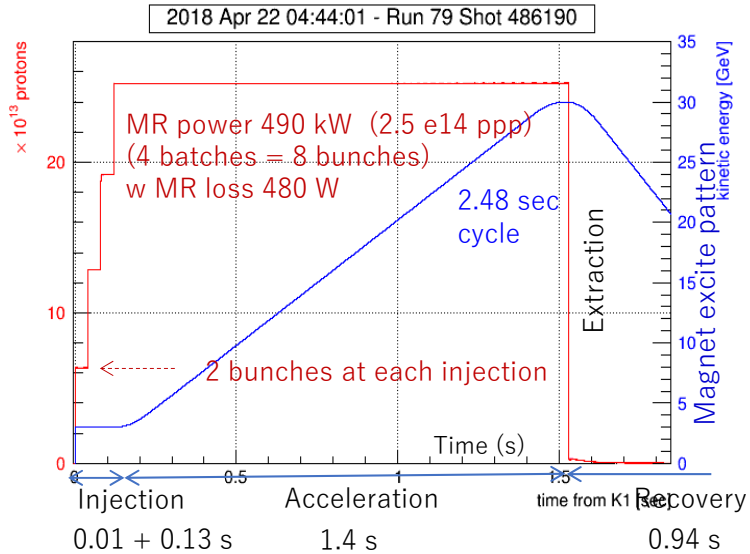

2018 Apr 22 04:29:30 - Run 79 Shot 485858

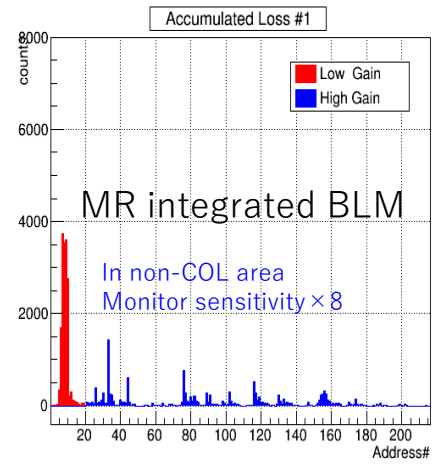
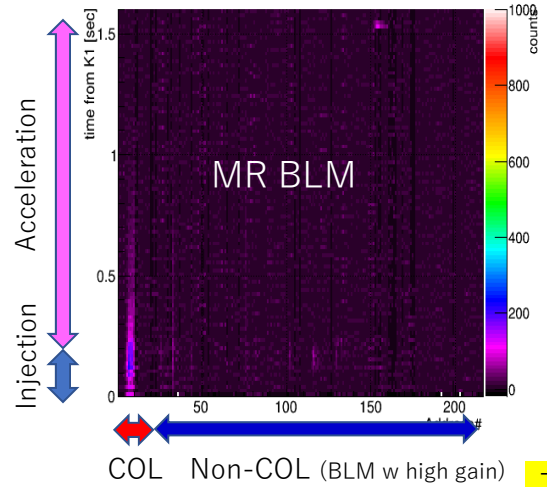

**MR power** 490 kW  
**3-50BT loss** 50 W < BT COL capacity 2 kW  
**MR loss** 480 W (\*1) < MR COL capacity 2 kW

*Injection* 230 W  
*Acc 1<sup>st</sup> 90 ms* 200 W  
*Acc after 90ms* 50 W

- Tuning Items:**
- RCS conditions
  - Operation point
  - Optics corr.
  - Resonance line corr.
  - Instability damping
  - Space charge effect mitigation
  - Collimator balancing

NOTE \*1: Beam loss estimated with DCCT#1.

- MR total loss, ~ 1%, is well localized in COL section and low energy, and less than the COL capacity
- Most of non-COL section: One foot residual doses are < 300  $\mu$ Sv/h (4H after operation)

# Beam loss sources and tuning items for fast extraction

## Beam loss sources in MR

- **Upstream beam quality from RCS:**
  - In Transverse, to choose optimal conditions with [3-50BT OTR monitor](#)
- **Physical aperture**
  - to hold effective aperture with closed orbit correction, optics correction
- **Emittance growth by Betatron resonances**
  - **To choose optimal operation point considering**
    - Tune spread by space charge
      - to control high bunching factor with [higher harmonic RF](#)
    - Tune spread by chromaticity
      - patterned Chromaticity correction with [sextupoles](#)
    - Resonance strength
      - to enlarge dynamic aperture by leakage field corrections with [Trim-quadrupoles](#)  
resonance corrections with [Skew-quadrupoles, Trim-Sextupoles](#)  
optics meas. & correction not only injection period but acceleration period
- **Emittance growth by beam instability (impedance from resistive wall)**
  - transverse feedback system (bunch by bunch, intra-bunch)
  - large tune spread (but acceptable level in betatron resonance)  
to suppress instabilities: optimizing bunching factor & chromaticity

Many Items  
to be optimized  
**iteratively**

## Choice of operation betatron tune (21.35, 21.43)

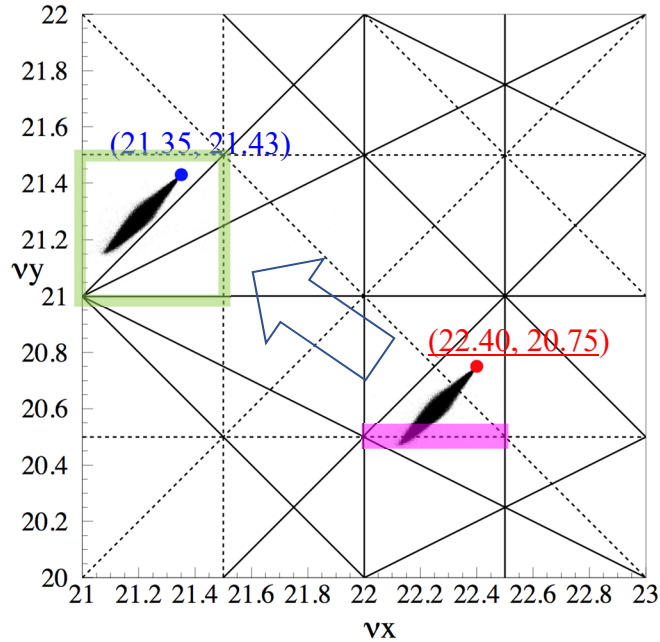

- Structure resonances of up to 3<sup>rd</sup> order (Solid lines)
- Non-structure resonances of half integer and linear coupling resonances (Dashed lines)

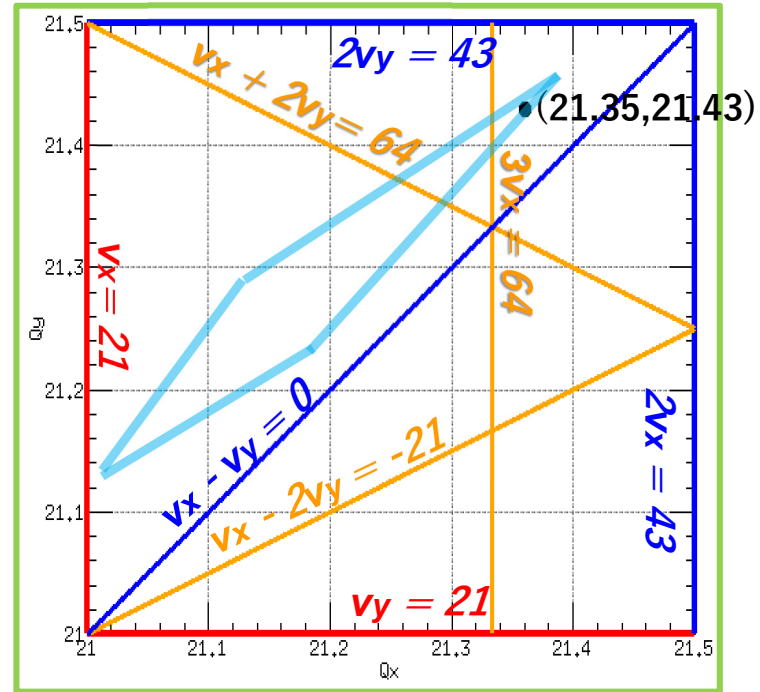

- Tune was shifted from (22.40, 20.75) to (21.35, 21.43) in 2016, to avoid the small tunability by  $v_y = 20.5$
- At the new tune (21.35, 21.43), to correct  $v_x + 2v_y = 64$  and  $3v_x = 64$  are important.  
 → Trim coils of 4 sextupoles have been optimized.

# Correction of the 3<sup>rd</sup> order resonances of both $\nu_x + 2\nu_y = 64$ and $3\nu_x = 64$

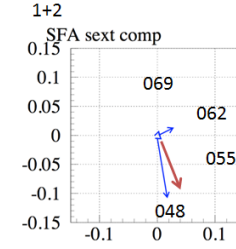
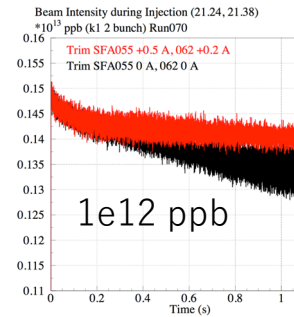
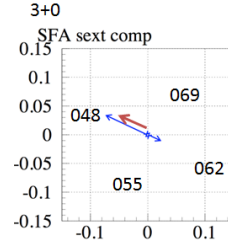
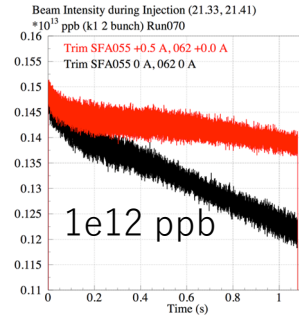
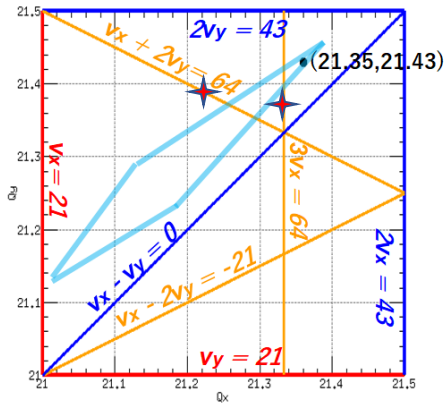

$$G_{3,0,64} = \frac{\sqrt{2}}{24\pi} \beta_x^{3/2} k_2 \exp[i(3\phi_x)]$$

$$G_{1,2,64} = \frac{\sqrt{2}}{8\pi} \beta_x^{1/2} \beta_y k_2 \exp[i(\phi_x + 2\phi_y)]$$

Activated trim-coils of 4 sextupole magnets locating independent phase

$$\sum_{j=2}^3 \frac{\sqrt{2}}{24\pi} \beta_x^{3/2}(j) k_2(j) \cos[3\phi_x(j)] \quad \text{Measured } G_{3,0,64} \text{ w 2 Trim-Ss}$$

$$\sum_{j=2}^3 \frac{\sqrt{2}}{8\pi} \beta_x^{1/2}(j) \beta_y(j) k_2(j) \cos[\phi_x(j) + 2\phi_y(j)] \quad \text{Measured } G_{1,2,64} \text{ w 2 Trim-Ss}$$

1 = T-SFA048, 2 = T-SFA055, 3 = T-SFA062, 4 = T-SFA069

- Scanning 2 trim-sextupoles identify the driven factors of  $\nu_x + 2\nu_y = 64$  and  $3\nu_x = 64$
  - 4 parallel eqs. provide a solution to correct both lines simultaneously with 4 trim-sextupoles
  - Beam losses were reduced with the correction not only injection but acceleration
  - We keep investigating the resonance sources.
- Residual magnetism of the resonance sextupoles (RSX) for SX  $\rightarrow$  degaussed in FX operation.

S. Igarashi et al.,  
Proc. HB2016,  
pp 21-26, 2016

# Correction of the 3<sup>rd</sup> order resonances of both $\nu_x + 2\nu_y = 64$ and $3\nu_x = 64$

S. Igarashi et al.,  
Proc. HB2016,  
pp 21-26, 2016

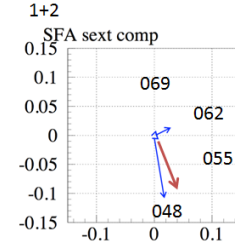
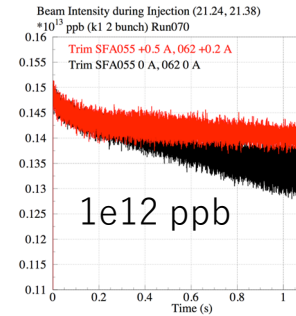
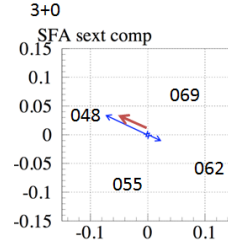
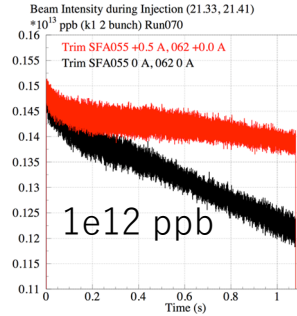
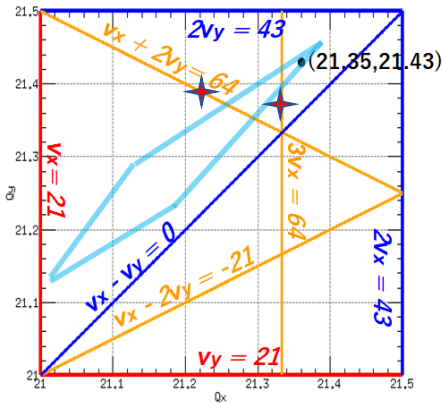

$$G_{3,0,64} = \frac{\sqrt{2}}{24\pi} \beta_x^{3/2} k_2 \exp[i(3\phi_x)]$$

$$G_{1,2,64} = \frac{\sqrt{2}}{8\pi} \beta_x^{1/2} \beta_y k_2 \exp[i(\phi_x + 2\phi_y)]$$

Calc.  $k_2$  of  
4 Trim-Ss  
for both  
G 3,0,64  
G 1,2,64

$$\sum_{j=1}^4 \frac{\sqrt{2}}{24\pi} \beta_x^{3/2}(j) k_2(j) \cos[3\phi_x(j)] =$$

$$\sum_{j=1}^4 \frac{\sqrt{2}}{24\pi} \beta_x^{3/2}(j) k_2(j) \sin[3\phi_x(j)] =$$

$$\sum_{j=1}^4 \frac{\sqrt{2}}{8\pi} \beta_x^{1/2}(j) \beta_y(j) k_2(j) \cos[\phi_x(j) + 2\phi_y(j)] =$$

$$\sum_{j=1}^4 \frac{\sqrt{2}}{8\pi} \beta_x^{1/2}(j) \beta_y(j) k_2(j) \sin[\phi_x(j) + 2\phi_y(j)] =$$

$$\sum_{j=2}^3 \frac{\sqrt{2}}{24\pi} \beta_x^{3/2}(j) k_2(j) \cos[3\phi_x(j)] =$$

$$\sum_{j=2}^3 \frac{\sqrt{2}}{24\pi} \beta_x^{3/2}(j) k_2(j) \sin[3\phi_x(j)] =$$

$$\sum_{j=2}^3 \frac{\sqrt{2}}{8\pi} \beta_x^{1/2}(j) \beta_y(j) k_2(j) \cos[\phi_x(j) + 2\phi_y(j)] =$$

$$\sum_{j=2}^3 \frac{\sqrt{2}}{8\pi} \beta_x^{1/2}(j) \beta_y(j) k_2(j) \sin[\phi_x(j) + 2\phi_y(j)] =$$

Measured

G 3,0,64

w 2 Trim-Ss

Measured

G 1,2,64

w 2 Trim-Ss

Equations for canceling both resonances, for  $k_2(1), k_2(2), k_2(3), k_2(4)$ .

1 = T-SFA048, 2 = T-SFA055, 3 = T-SFA062, 4 = T-SFA069

- Scanning 2 trim-sextupoles identify the driven factors of  $\nu_x + 2\nu_y = 64$  and  $3\nu_x = 64$
  - 4 parallel eqs. provide a solution to correct both lines simultaneously with 4 trim-sextupoles
  - Beam losses were reduced with the correction not only injection but acceleration
  - We keep investigating the resonance sources.
- Residual magnetism of the resonance sextupoles (RSX) for SX  $\rightarrow$  degaussed in FX operation.

# Correction of the 3<sup>rd</sup> order resonances of both $\nu_x + 2\nu_y = 64$ and $3\nu_x = 64$

S. Igarashi et al.,  
Proc. HB2016,  
pp 21-26, 2016

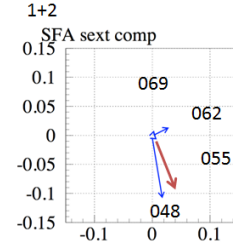
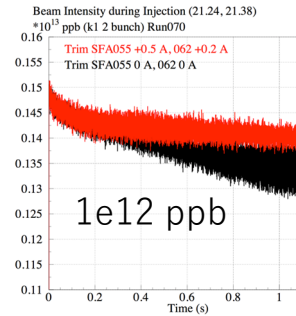
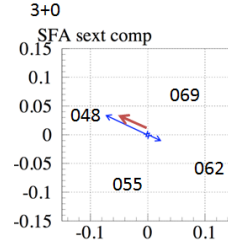
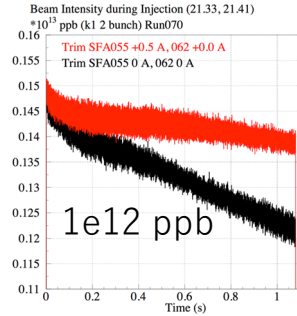
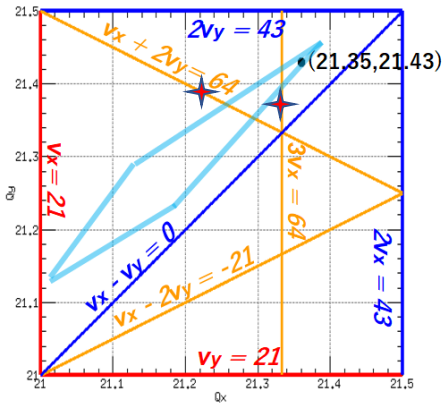

$$G_{3,0,64} = \frac{\sqrt{2}}{24\pi} \beta_x^{3/2} k_2 \exp[i(3\phi_x)]$$

$$G_{1,2,64} = \frac{\sqrt{2}}{8\pi} \beta_x^{1/2} \beta_y k_2 \exp[i(\phi_x + 2\phi_y)]$$

Calc.  $k_2$  of  
4 Trim-Ss  
for both  
G 3,0,64  
G 1,2,64

$$\sum_{j=1}^4 \frac{\sqrt{2}}{24\pi} \beta_x^{3/2}(j) k_2(j) \cos[3\phi_x(j)] = \sum_{j=2}^3 \frac{\sqrt{2}}{24\pi} \beta_x^{3/2}(j) k_2(j) \cos[3\phi_x(j)]$$

$$\sum_{j=1}^4 \frac{\sqrt{2}}{24\pi} \beta_x^{3/2}(j) k_2(j) \sin[3\phi_x(j)] = \sum_{j=2}^3 \frac{\sqrt{2}}{24\pi} \beta_x^{3/2}(j) k_2(j) \sin[3\phi_x(j)]$$

$$\sum_{j=1}^4 \frac{\sqrt{2}}{8\pi} \beta_x^{1/2}(j) \beta_y(j) k_2(j) \cos[\phi_x(j) + 2\phi_y(j)] = \sum_{j=2}^3 \frac{\sqrt{2}}{8\pi} \beta_x^{1/2}(j) \beta_y(j) k_2(j) \cos[\phi_x(j) + 2\phi_y(j)]$$

$$\sum_{j=1}^4 \frac{\sqrt{2}}{8\pi} \beta_x^{1/2}(j) \beta_y(j) k_2(j) \sin[\phi_x(j) + 2\phi_y(j)] = \sum_{j=2}^3 \frac{\sqrt{2}}{8\pi} \beta_x^{1/2}(j) \beta_y(j) k_2(j) \sin[\phi_x(j) + 2\phi_y(j)]$$

$$\sum_{j=2}^3 \frac{\sqrt{2}}{24\pi} \beta_x^{3/2}(j) k_2(j) \cos[3\phi_x(j)] = \text{Measured } G_{3,0,64}$$

$$\sum_{j=2}^3 \frac{\sqrt{2}}{24\pi} \beta_x^{3/2}(j) k_2(j) \sin[3\phi_x(j)] = \text{w 2 Trim-Ss}$$

$$\sum_{j=2}^3 \frac{\sqrt{2}}{8\pi} \beta_x^{1/2}(j) \beta_y(j) k_2(j) \cos[\phi_x(j) + 2\phi_y(j)] = \text{Measured } G_{1,2,64}$$

$$\sum_{j=2}^3 \frac{\sqrt{2}}{8\pi} \beta_x^{1/2}(j) \beta_y(j) k_2(j) \sin[\phi_x(j) + 2\phi_y(j)] = \text{w 2 Trim-Ss}$$

Equations for canceling both resonances, for  $k_2(1), k_2(2), k_2(3), k_2(4)$ .

1 = T-SFA048, 2 = T-SFA055, 3 = T-SFA062, 4 = T-SFA069

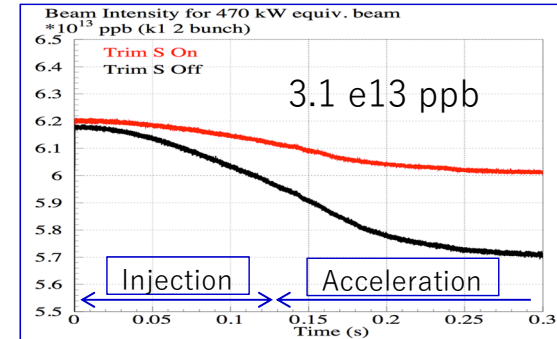
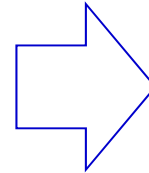

- Scanning 2 trim-sextupoles identify the driven factors of  $\nu_x + 2\nu_y = 64$  and  $3\nu_x = 64$
  - 4 parallel eqs. provide a solution to correct both lines simultaneously with 4 trim-sextupoles
  - Beam losses were reduced with the correction not only injection but acceleration
  - We keep investigating the resonance sources.
- Residual magnetism of the resonance sextupoles (RSX) for SX  $\rightarrow$  degaussed in FX operation.

# FX Septum Leak field

QFR 154	SM11- 22	QDT 155	SM30- 33	QFP 156
------------	-------------	------------	-------------	------------

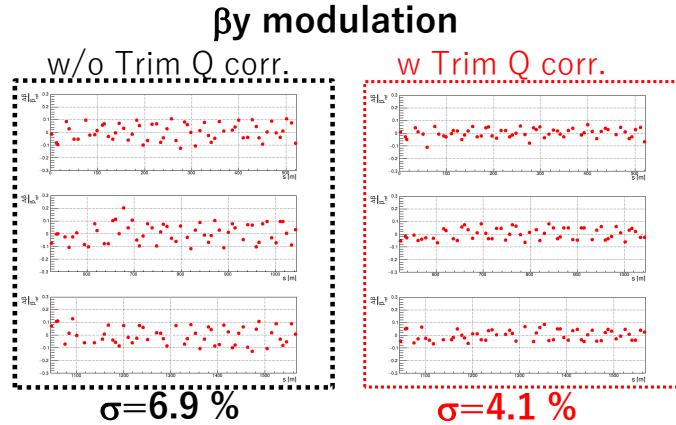
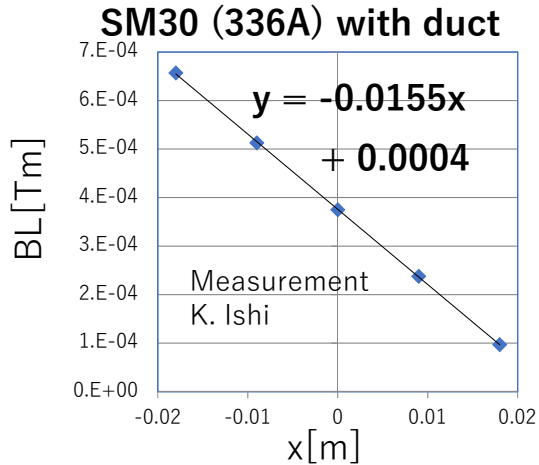

Kurimoto, et al.

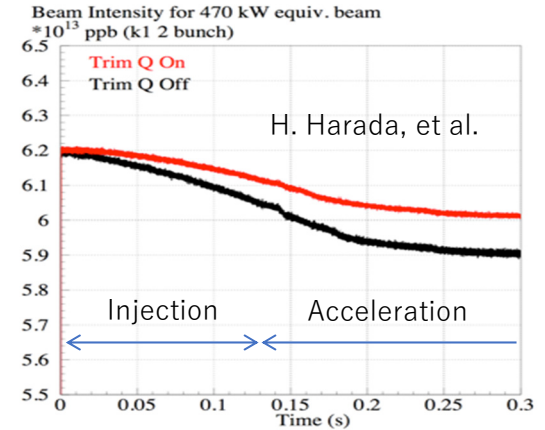

- **Leak field of 8 FX septum magnets corresponds to ~3% of K1 of the main Q magnet.**  
→ One of main sources of beam optics modulation and reduce MR physical aperture
- **Trim coils of 3 Q magnets have been used to correct the leak field of FX septum magnets.**
- All main quadrupoles are also adjusted to correct beam optics (tune, beta, phase advance, dispersion, chromaticity) in not only injection but also acceleration.
- **The beam loss was reduced with these adjustments.**

# Longitudinal Profiles with high intensity (500 kW eq.)

(100 kV, 0 kV)

Bunching factor  $0.2 \sim 0.3$

Bunch length  $\sim 200$  ns

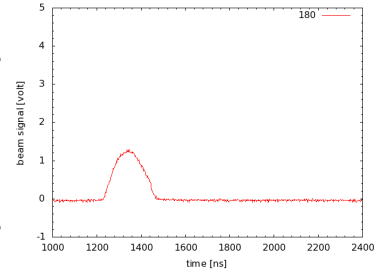
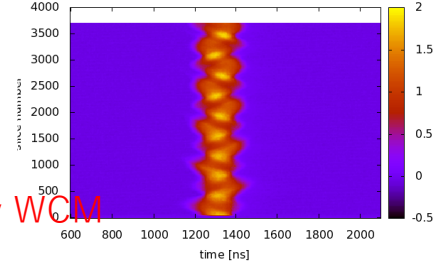
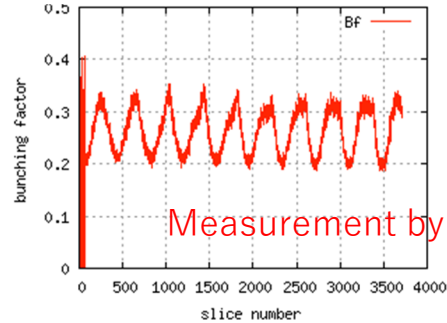
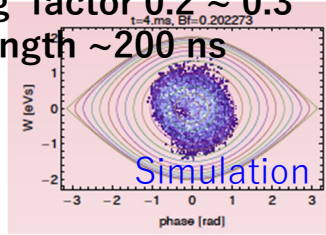

(100 kV, 70 kV)

Bunching factor  $0.3 \sim 0.4$

Bunch length  $\sim 400$  ns

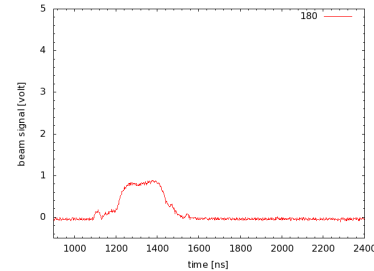
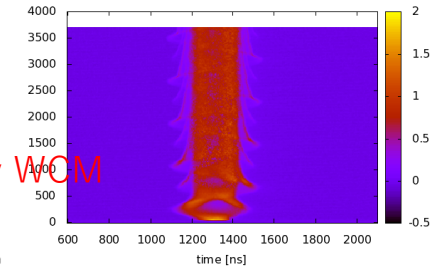
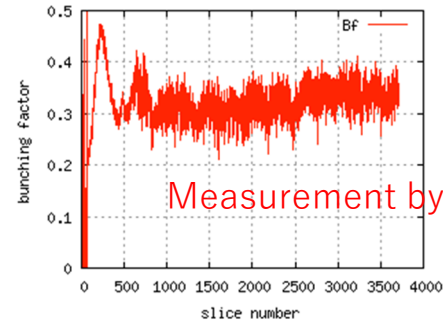
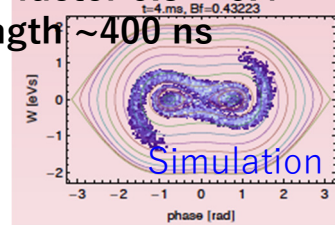

- Large amplitude voltage of 2<sup>nd</sup> harmonic RF, over 50% to fundamental harmonic RF, is adopted
- Longitudinal mismatch is purposely used to suppress space charge effect promptly

# Instability Suppression (1) Chromatic Pattern

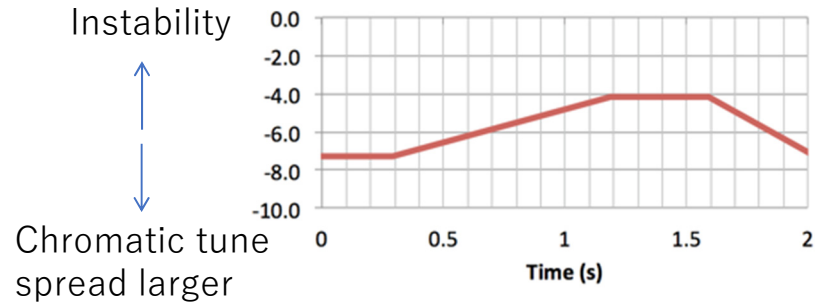
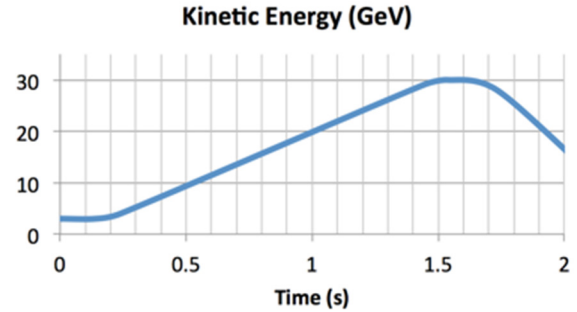
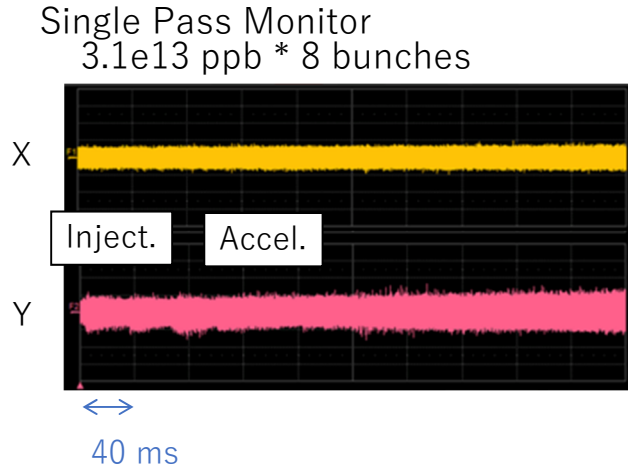

- The chromaticity pattern was set to minimize the beam loss, and kept in negative value
- If the chromaticity is too small, we observe instability
- If the chromaticity is too large, we observe the beam loss due to chromatic tune spread
- This pattern scheme works but is not enough for high intensity operation

# Instability Suppression (2) Transverse Feedback System

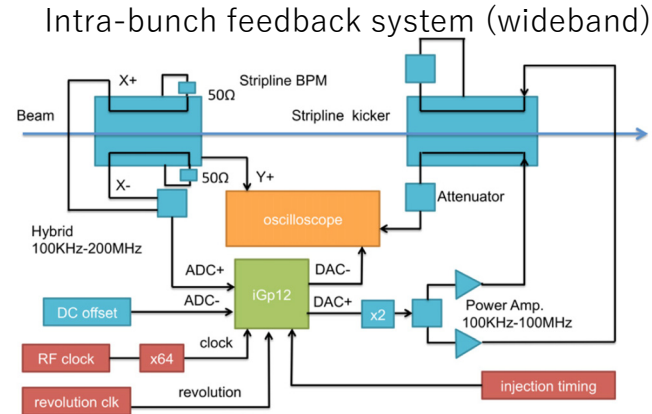
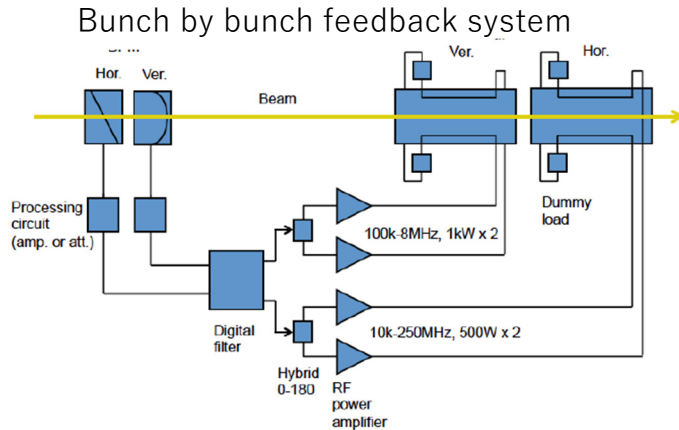

Beam Position with Intra-bunch FB off



P1+100 ms P2

Beam Position with Intra-bunch FB on

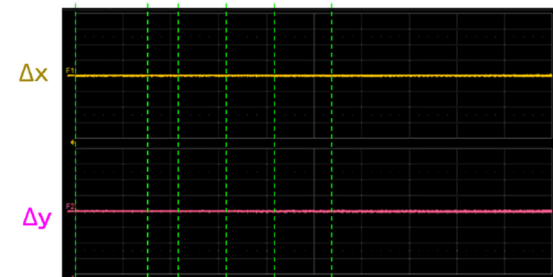

P1+100 ms P2

- The bunch by bunch and intra-bunch feedback system were developed to suppress coherent oscillation. It is damped well during injection and the beginning of acceleration
- The feedback system is indispensable for high intensity operation

# Tune tracking for bunch train tune shift (1)

Bunch train tune shift in case of PEP-II octagonal chamber in dipoles (A. Chao, et al., PRSTAB, 5, 111001 (2002))

$$\Delta\nu_{x,y} = \pm \frac{\Gamma}{2\omega_0\omega_{x,y}} h \approx \pm \frac{\Gamma}{2\omega_0\omega_{x,y}} \frac{rb}{\delta_0} = \pm \frac{1}{48} \frac{rNr_0L}{\gamma b^2 \nu_{x,y}}$$

N: total number of particles in beam  
L: Length of octagonal chamber  
b: half of vertical separation  
r: parameter of impedance

MR tunes are shifted by Quadrupolar Wake of non-circular beam pipe ( $d\nu_x = +0.02$ ,  $d\nu_y = -0.02$ )

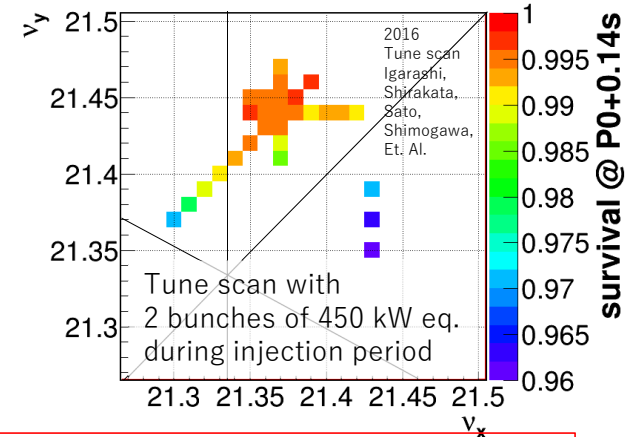
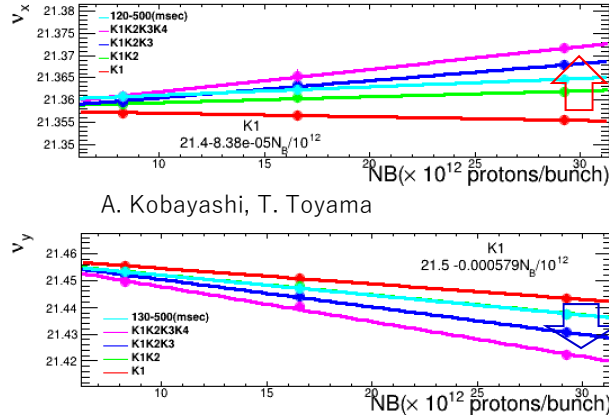
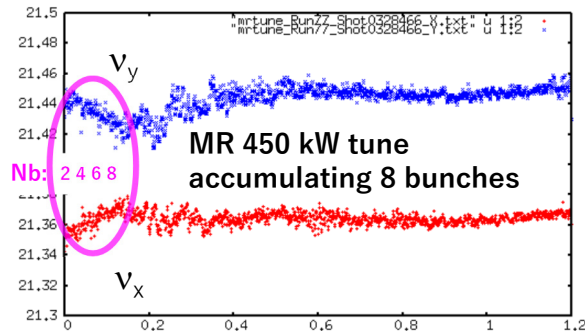

- Non-circular beam pipe causes bunch train tune shift as a whole ring.
- In MR, the bunch train tune shift during injection was observed for high intensity beam > 450 kW, though best survival betatron tune is in limited area

# Tune tracking for bunch train tune shift (2)

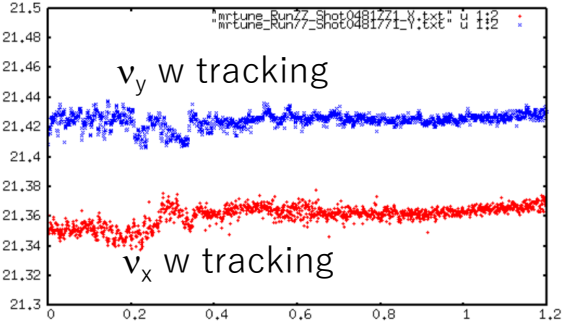
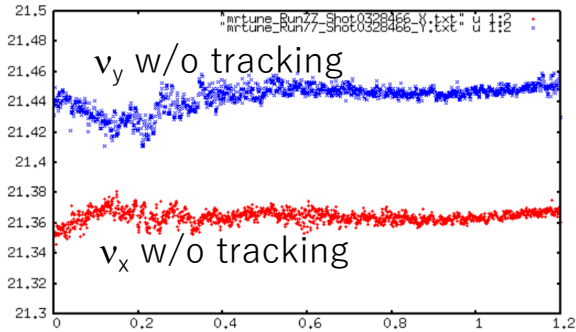

Power 450 kW  
Loss 850 W

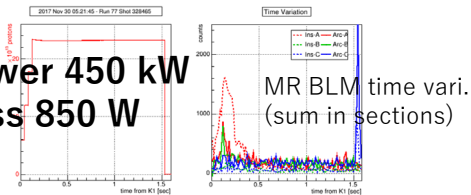

Power 451 kW  
Loss 590 W

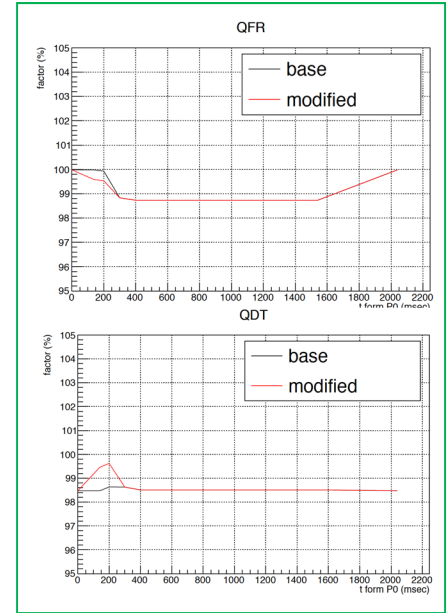
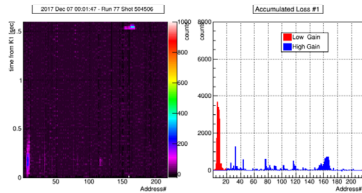
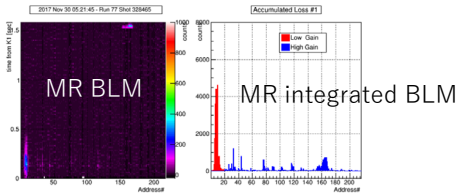
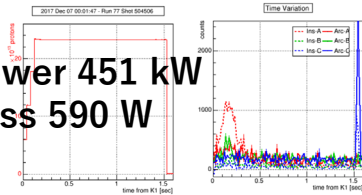

**490 kW user operation achieved By this trick.**

Beam survival was improved with correction of the tune shift.  
*New power supply of QFR (prepared for MR upgrade) enabled this tune tracking.*  
 → Stable 490 kW user operation (*Trim-Sextupoles/Octupole/MR COL were tuned also*)

# Beam loss localization with MR Collimators

MR Collimator System 2017 Fall 2.0 kW

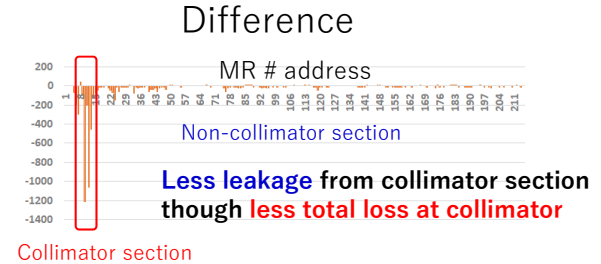
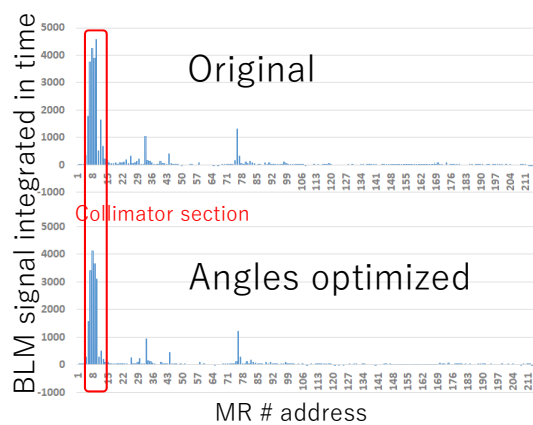
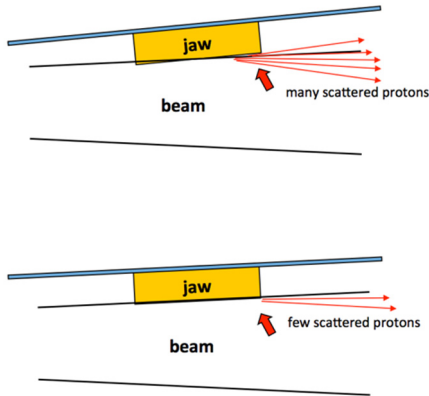
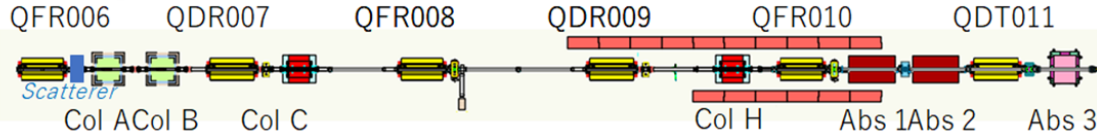

M. Shirakata, Y. Sato

- Collimators C and D have angle adjustment capability
- Fitting the collimator jaws to beam envelopes reduced loss leakage in non-collimator section
- Additional rotational collimators are considered to be installed.

# Residual Radiation and Beam Losses during Operation

- Residual radiation is measured 4 hours after the 478 kW operation on 2018/4/12
- One foot < 300  $\mu\text{Sv/h}$  in most of non-collimator section
- High-radiated points in non-collimator section are as follows:

One foot [ $\mu\text{Sv/h}$ ]	QFN029	QFX033	BM QDX044	QFT075 ESS	ESS QFP076	QDX089	BM QDX116	QFN117	SM2 QDT155	SM30 QFP156
3/22	100	300	200	400	600	500	200	300	1000	300
3/27	100	300	250	700	600	700	150	350	1000	300
4/2		200	250	350	450	350	180	300	700	300
4/12		250	250	400	400	400	150	500	800	350

- At these places beam losses are observed to be 100 ~ 1500 of Integ-BLM counts during operation

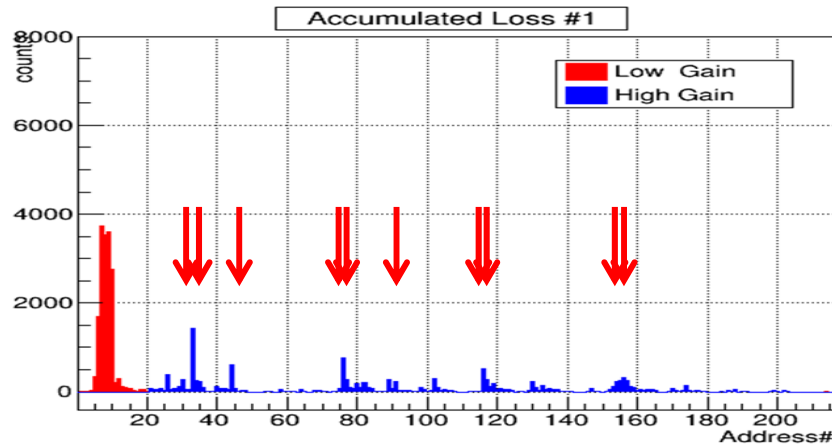

→ Enough eyes to manage them

- Residual activation is well controlled with high power beam operation
- Less beam loss and better loss localization are under studied, observing BLM signal

# High Intensity Trial at 520 kW

**MR power 520 kW (2.68e14 ppp)**  
**3-50BT loss 200 W**  
 < BT COL capacity 2 kW  
**MR loss 1 kW (\*1)**  
 < MR COL capacity 2 kW  
*Injection 450 W*  
*Acc 1<sup>st</sup> 90 ms 460 W*  
*Acc after 90ms 90 W*

NOTE \*1: Beam loss estimated with DCCT#1.

- Losses at the beginning of the acceleration: ArcB loss (@ high  $\beta_y$ )
- V-profile was large @ NU.
- Optimization necessary for loss reduction.
- Longitudinal oscillation enlarged but no leakage from RF bucket
- RF#3 anode current 100 A

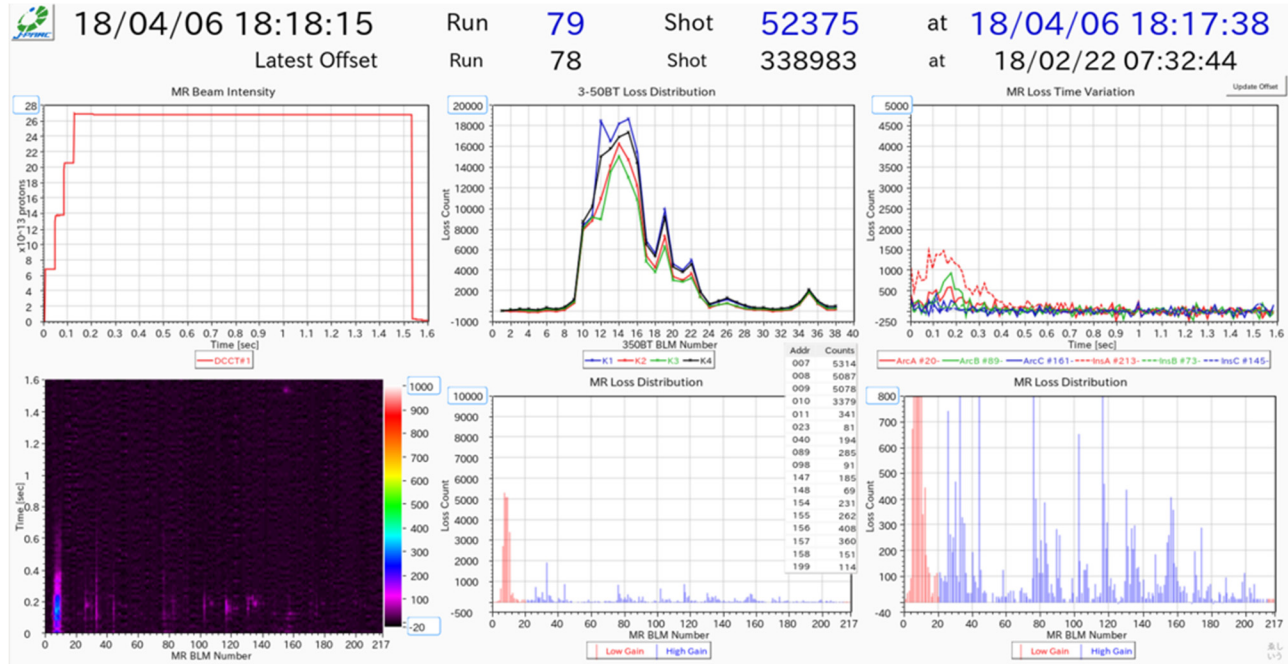

- **520 kW in 2.48 s cycle shows no significant total loss with ~ 2%.**  
 → 1.1 MW capability demonstrated in 1.16 s near-future-cycle
- **Beam loss collimation is needed. We can perform iterative tunings of Tune/ IntraBFB/ RF/ Sextupoles/ Trim-S/ Octupoles** for less losses and better loss localization in > 520 kW
- **We are developing longitudinal feedback system newly, also**

# Study for MR upgrade plan

- Beam Power Upgrade Concept
- Scatterer test device

# Beam Power Upgrade Concept

- The operation of 490 kW has been achieved so far with the cycle time of 2.48 s and the accelerated protons of  $2.5 \times 10^{14}$  ppp.
- The beam power of 1.3 MW is planned with the faster cycling of 1.16 s and the accelerated protons of  $3.3 \times 10^{14}$  ppp.
- Hardwares (Magnet PS/ RF/ Colli/ Inj&FX/...) are under preparation
- **The most powerful neutrino beam can be realized in several years.**

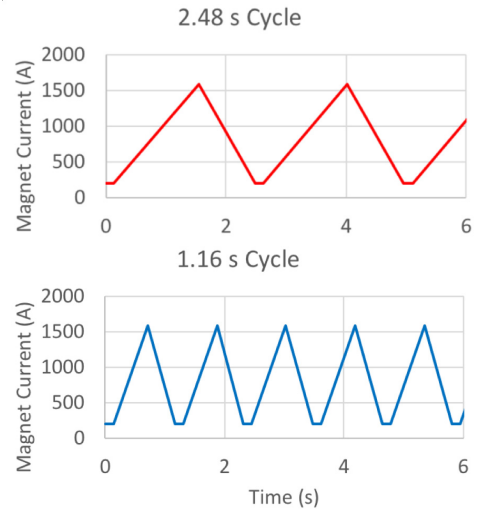

Beam Power	Cycle time	Protons per pulse (ppp)	Protons per bunch (ppb)	Eq. beam power in RCS
490 kW	2.48 s	$2.5 \times 10^{14}$	$3.1 \times 10^{13}$	760 kW
520 kW	2.48 s	$2.7 \times 10^{14}$	$3.4 \times 10^{13}$	810 kW
750 kW	1.3 s	$2.0 \times 10^{14}$	$2.5 \times 10^{13}$	610 kW
1.3 MW	1.16 s	$3.3 \times 10^{14}$	$4 \times 10^{13}$	1 MW

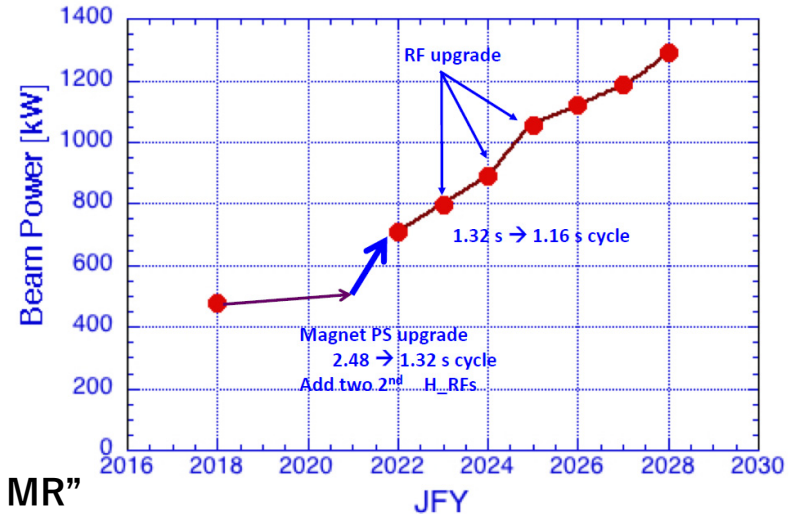

# Scatterer Test Device with MR Collimators

MR Collimator System 2017 Fall 2.0 kW

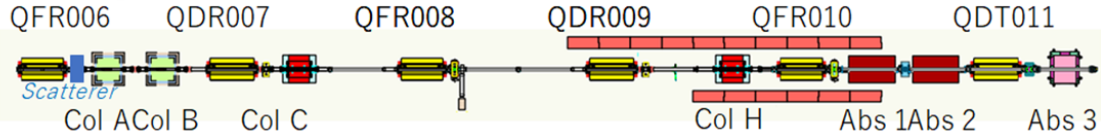

Beam test with 450 kW eq.  
(2 bunches)

V Scatt: Full Open >  $80\pi$

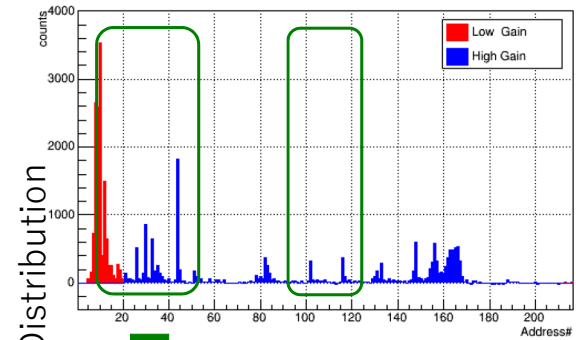

V Scatt:  $60\pi$

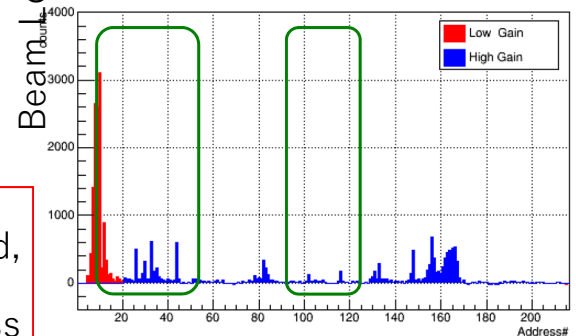

Normalized phase space in Y - PY

V-Scatt:  $60\pi$

V-Col3V  
(down)  
 $75\pi$

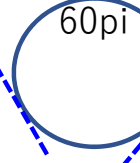

V-ColB(up)  
 $60\pi$

If Vup-Scatt Full open, more BLM counts in Col3V down stream

Y. Sato, Y. Hashimoto, Y. Kurimoto, M. Shirakata, et. al.

- In the faster cycle itself, beam loss will increase linearly.
- In the view of beam operation, loss localization is important
- 2 stage collimator scenario, using thin-plates as scatterer, is under studied, besides adding new collimators having angle adjusted jaws.
- Successful beam test: Less loss leakage without increasing total beam loss

# Scatterer Test in Beam Simulation

ScatVup  $> 81\pi$  COLBV  $60\pi$  COL3DV  $75\pi$

ScatVup  $60\pi$  COLBV  $60\pi$  COL3DV  $75\pi$

Beam loss distribution in non-COL area

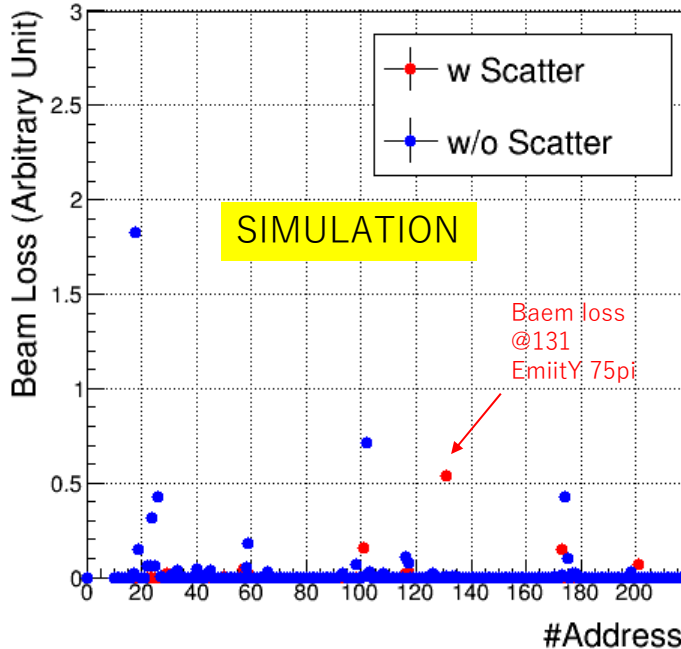

Geant4 for scattering + sad for tracking  
 Scattered at Scatterer Vup /COL B V  
 Independent scattered angles in  
 X-X' and Y-Y'  
 COLA,COLC H-Physical aperture  $75\pi$   
 Non-collimator physical aperture  $> 81\pi$

Y. Kurimoto

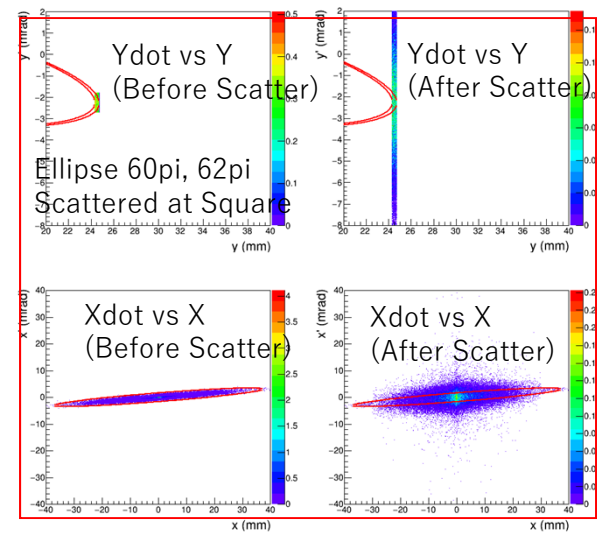
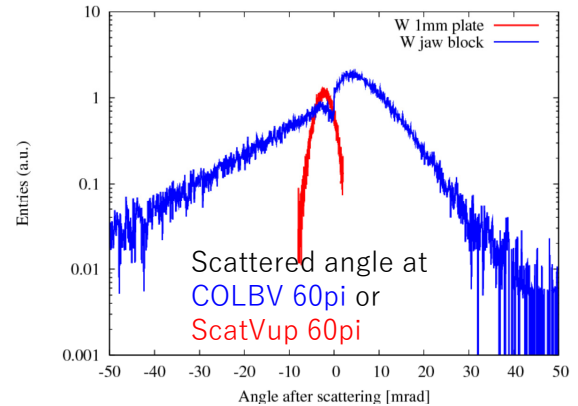
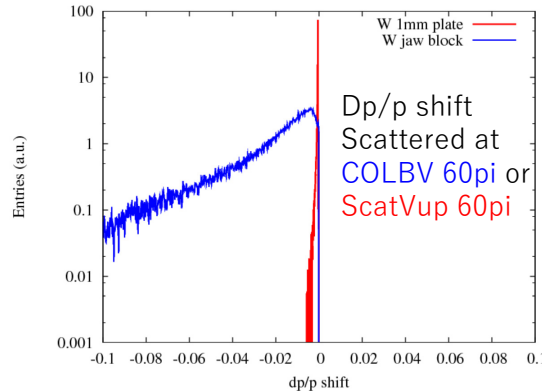

Scatter effect was well simulated in the beam loss distribution

# MR with slow extraction

- Typical operation
- Fine tunings for Extraction Efficiency

# Typical operation of MR 50 kW with 30 GeV slow extraction to HD

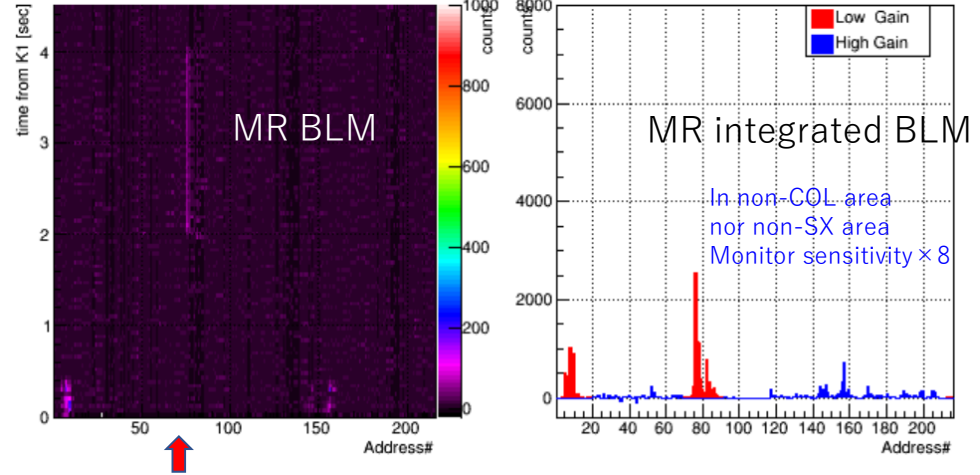
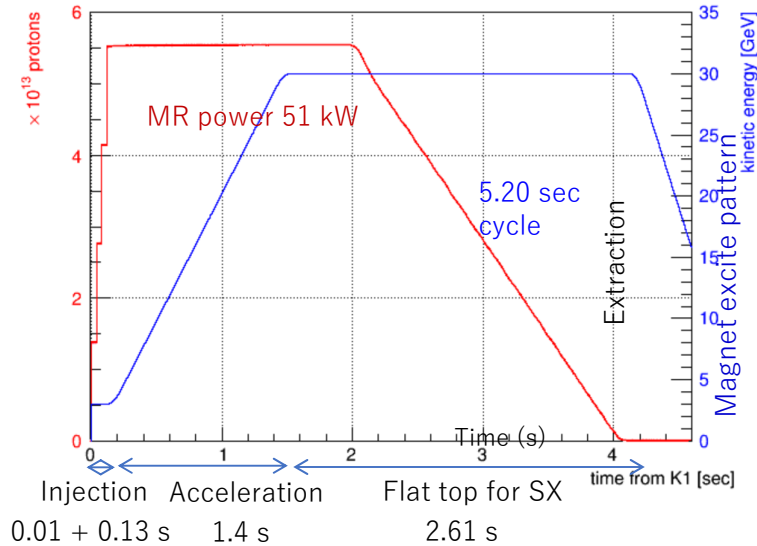

Main loss at SX region (especially at the electrostatic septum)

MR power  
Efficiency  
Spill Duty  
Spill length

51.1 kW in 5.20 s cycle  
99.52% Extraction Efficiency Trend  
48%  
2.05 s

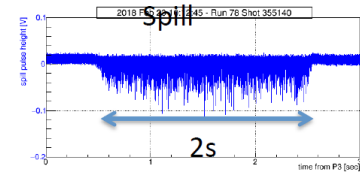
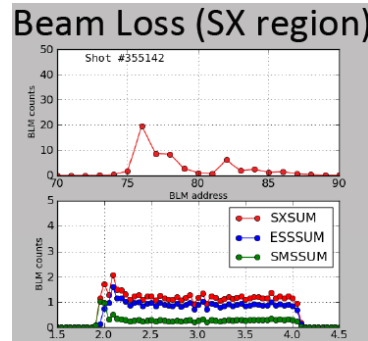
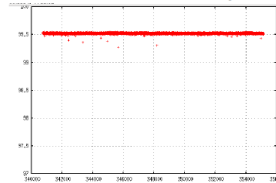

# Fine Tunings for Extraction Efficiency

- Besides basic SX tuning, fine tunings were necessary with
  - ESS1 angle
  - ESS2 position and angle
  - SMS1 position
  - Bump orbit with Dynamic Bump

fixed bump

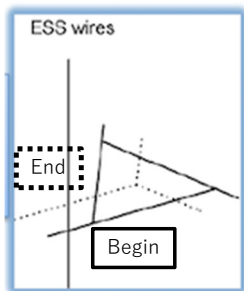

dynamic bump

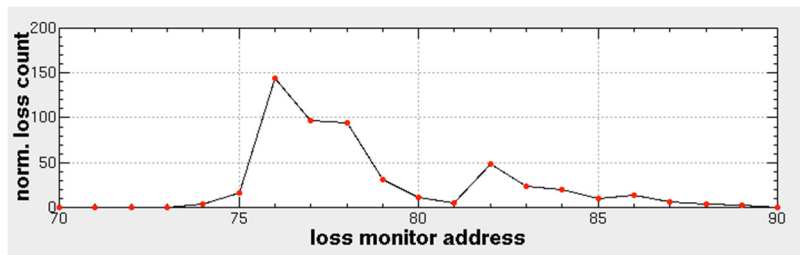
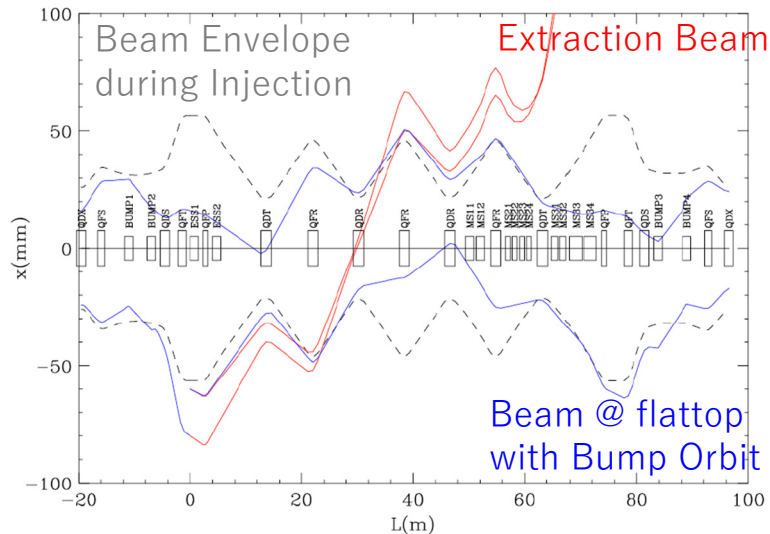
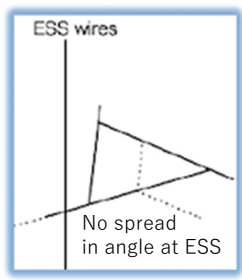

ESS1 2

SMS1 2 3

To keep same separatrix at ESS is important

# Summary

- 1 MW acceleration in the RCS was successfully demonstrated with minimum beam losses. Pulse-by-pulse switching of major parameters for MLF and MR is in operation.
- MR with fast extraction achieved stable 490 kW (2.5 e14 protons per pulse) operation without significant beam loss. Changing operation point was a big key to increase the beam power.
- MR upgrade is planned with preparing faster cycle (from 2.48 s to 1.3 s and 1.16 s) to achieve 1.3 MW. 80% of required protons were accelerated in 2.48 s cycle.
- MR with slow extraction achieved 51 kW operation with 99.5% efficiency.

**Thank you for listening!**