

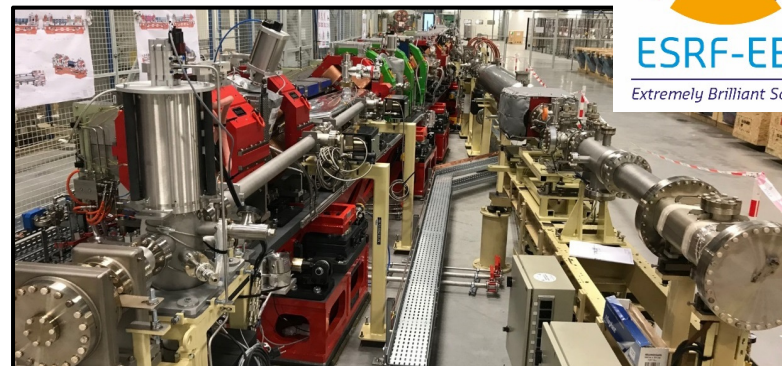

STATUS OF THE ESRF EXTREMELY BRILLIANT SOURCE PROJECT

Jean-Luc Revol,
on behalf of the EBS Accelerator Project Team



The European Synchrotron

9th International Particle Accelerator Conference
Vancouver, Canada
April 29 - May 4, 2018

- **Introduction to the ESRF**
- **The Upgrade Programme**
- **Brief description of the project**
- **Design and procurement**
- **Installation and commissioning**

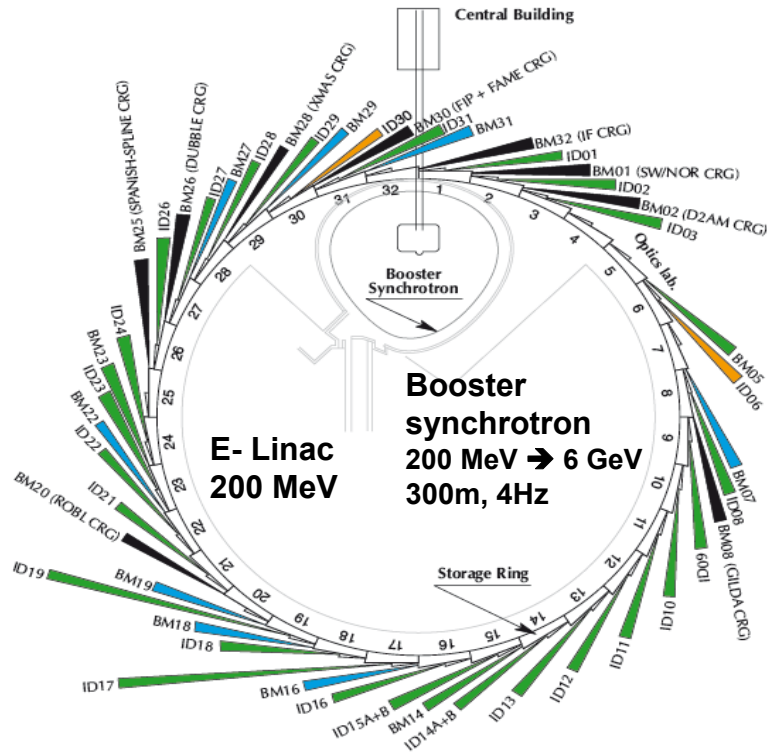

844 m circumference storage ring
DBA lattice, 32 straight sections

42 Beamlines
(including 12 on Bending Magnets)

Third generation light source

Location: Grenoble, France
Cooperation: 22 partner nations
Annual budget: 100 million €
Staff: 630
Start User Mode: 1994

Energy	6.04	GeV
Multibunch current	200	mA
Horizontal emittance	4	nm.rad
Vertical emittance	4	pm.rad

Availability: 98.75 %
Mean Time Between Failures: 89.4 hours
Average over the last 4 years

- 9,000 scientific visits every year
- 1800 publications every year

2009-2022 – UPGRADE PROGRAMME

2009
2015 Upgrade PHASE I – 180 M€

- New beamlines (19 experimental stations)
- New ultra-stable experimental hall
- Improvement and refurbishment scientific equipment and accelerator infrastructure

150 M€ – ESRF-EBS

2015
2022

- **Construction of a new storage ring**
- Construction of 4 new beamlines
- Ambitious instrumentation program

Purple
Book
January
2008



Orange
Book
January
2015

EXTREMELY BRILLIANT SOURCE: ACCELERATOR UPGRADE

The accelerator Upgrade Phase II aims to:

- ✓ Substantially decrease the Storage Ring Equilibrium Horizontal Emittance
- ✓ Increase the source brilliance
- ✓ Increase its coherent fraction

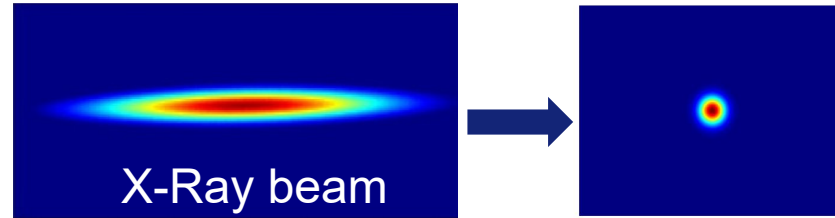

In the context of the R&D on Ultimate Storage Ring, the ESRF has developed a solution, based on the following requirements and constraints:

- Reduce the horizontal equilibrium emittance from 4 nm.rad to 133 pm.rad
- Maintain the existing Insertion Device (ID) and Bending Magnet beamlines
- Preserve the time structure operation and a multi-bunch current of 200 mA
- Keep the present injector complex and infrastructure
- Limit the downtime for installation and commissioning to 18 months.
- **Maintain standard User-Mode Operations** until the day of shut-down for installation

THE HYBRID MULTI-BEND ACHROMAT (HMBA) LATTICE

- Multi-bend and longitudinal gradient in the dipole for lower emittance
- Dispersion bump for efficient chromaticity correction, and thus weaker sextupoles
- Fewer sextupoles than in DBA
- No need of “large” dispersion on the inner dipoles, giving small invariant and thus small emittance.

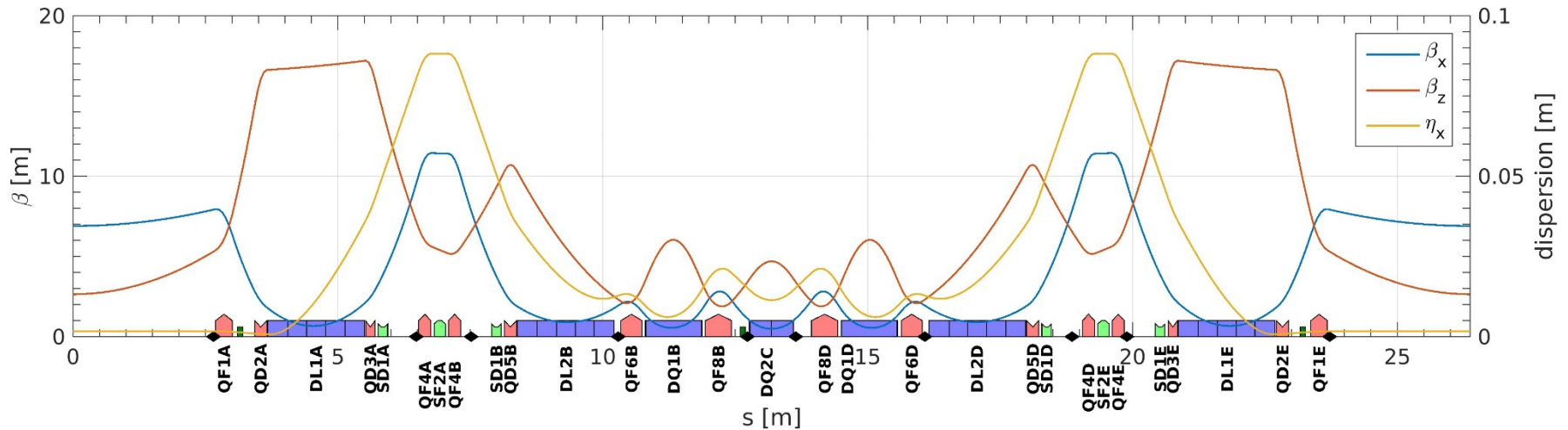

Pantaleo Raimondi, IPAC'17

NEW LATTICE VS PRESENT ESRF LATTICE

▪ Present ESRF lattice

32 cells, Double Bend Achromat = (2 dipoles + 8 quad. 7sext.) per cell
ID length = 5 m (standard) / 6m / 7m

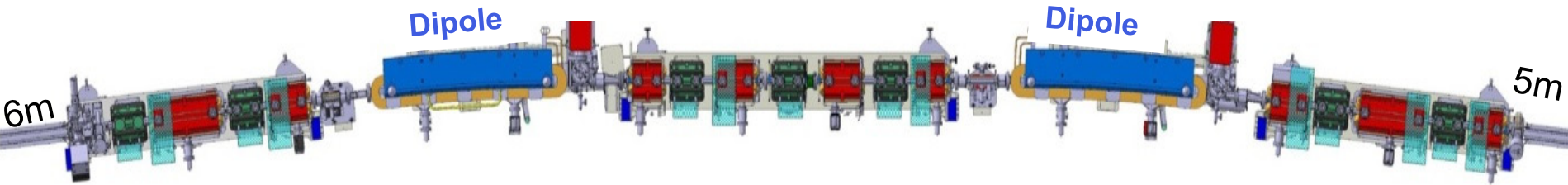

▪ ESRF EBS lattice

Hybrid 7 Bend Achromat = (4 dipoles + 3 dipoles-quad + 16 quad., 6 sext., 2 oct.) per cell
32 identical arcs 21.2 m long, ID length = 5 m

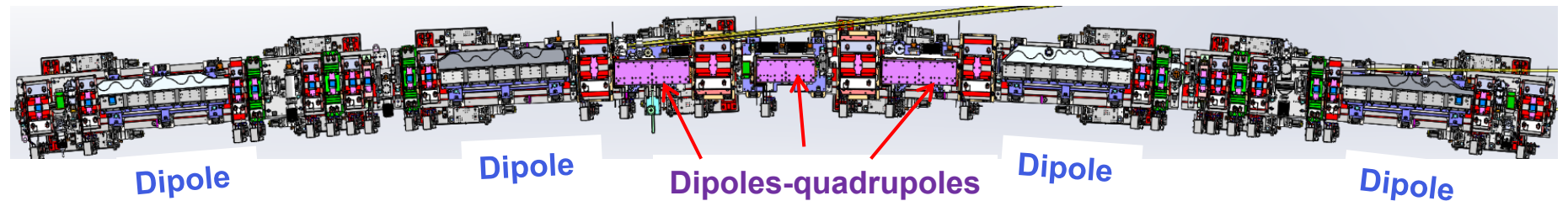

*31 magnets per cell instead of 17 currently
Free space between magnets (total for one cell): 3.4m instead of 8m today !!*

PLANNING

October	2017	Start of the girder assembly (12 months)
10 December	2018	Start of the long shutdown (18 Months)
		Dismantling (3 months) and Installation (9 months)
December	2019	Accelerator commissioning
March	2020	Beamline commissioning
25 August	2020	Back to USM

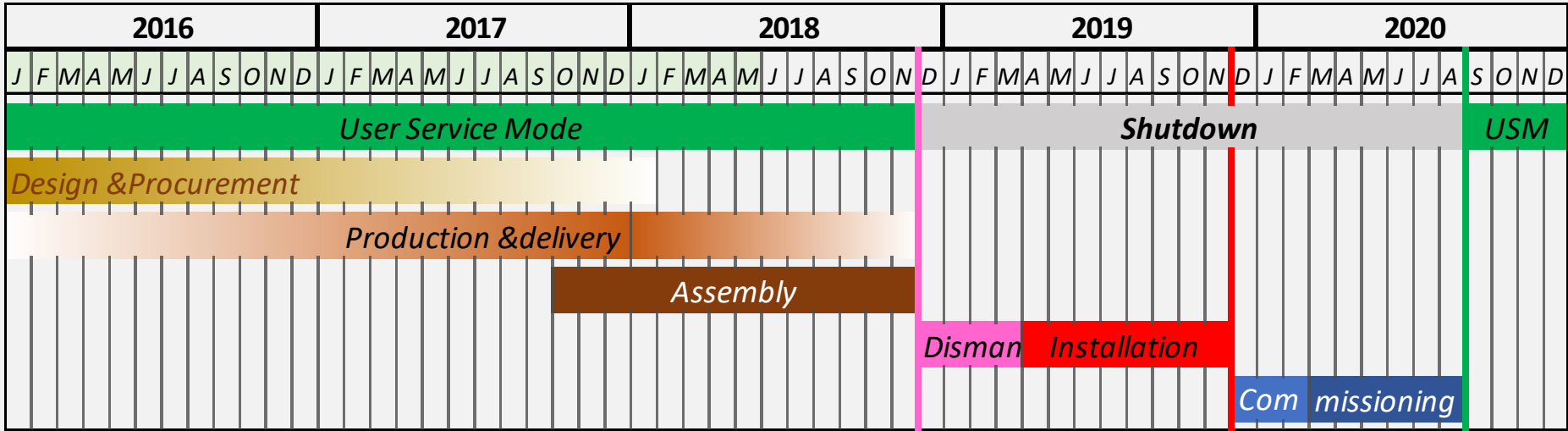

MAGNET SYSTEM

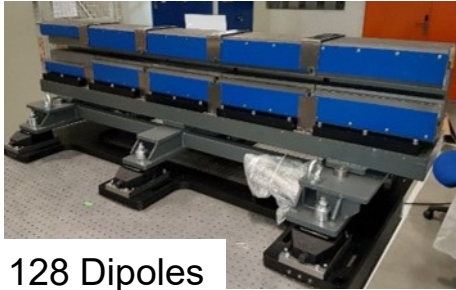

128 Dipoles
Assembled in house

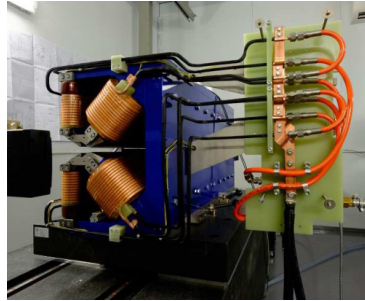

96 Dipole-quadropoles



96 Correctors

More than 1000 Magnets procured in less than 3 years



512 Quadrupoles
(128 HG, 384 MG)

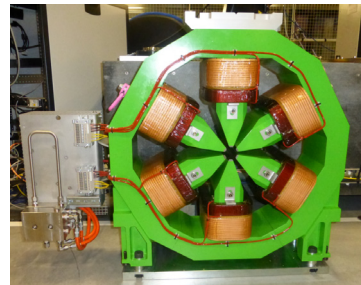

192 Sextupoles

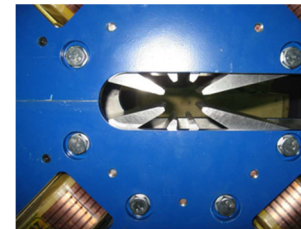

64 Octupoles

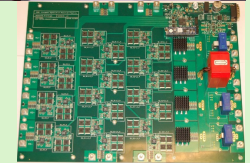

DC-DC converters
in procurement to
power each
magnet individually

GIRDERS & SUPPORTS

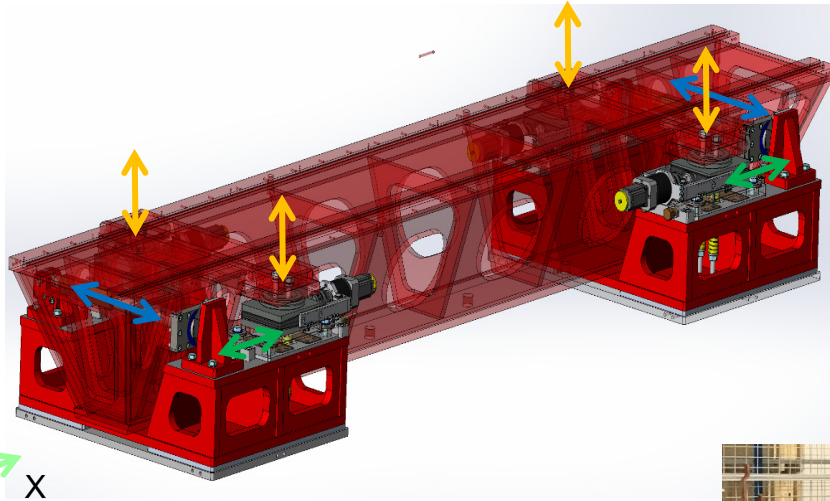

4 girders per cell
Central DQ2 sitting between 2 girders

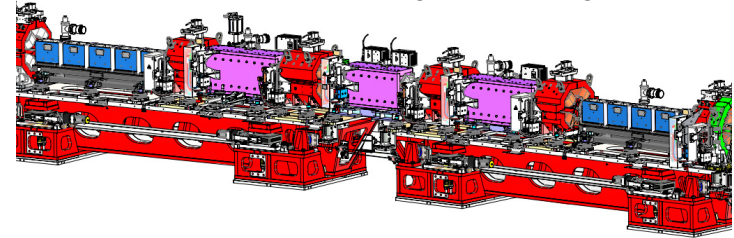

- Girder supported by 4 adjustable Z feet made of motorised wedges
- Y adjustment by 2 manual jacks pushing the girder
- 1st natural frequency: 49 Hz measured



MOCK-UP

Sept. 2017: One full cell assembled including straight section, front-ends and services
(Cables trays, connection boxes, cooling pipes,)

- ✓ Validation of the engineering prior series production
- ✓ validation of the assembling and installation procedures

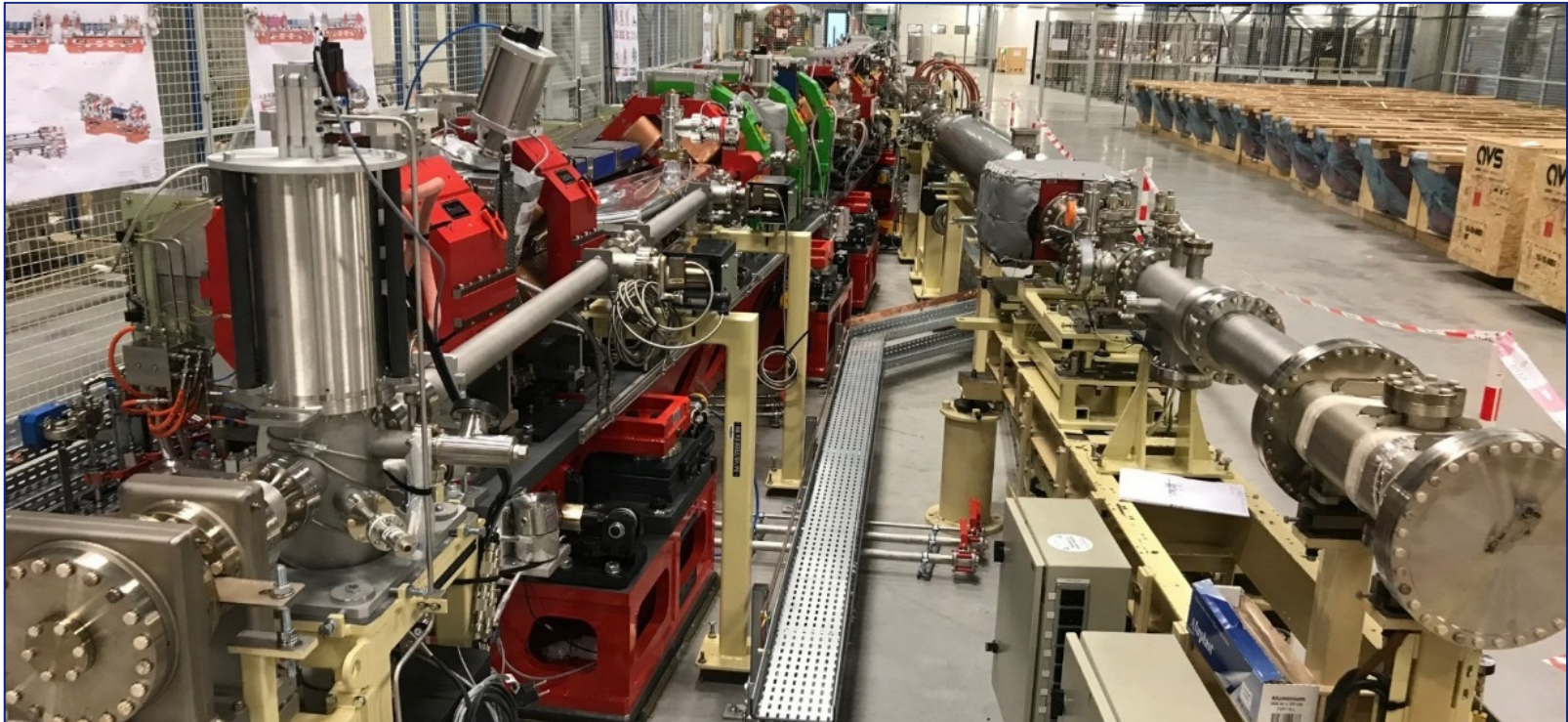

ASSEMBLY



- Week 1:
- Position girders
 - Install magnets & align
 - Open magnets

- Week 2:
- Install pre-assembled chambers
 - Align BPM's & chambers
 - Close magnets

- Week 3:
- Cooling installation
 - Final alignment
 - Move girder outside

- Each week:
- Vacuum chambers preparation

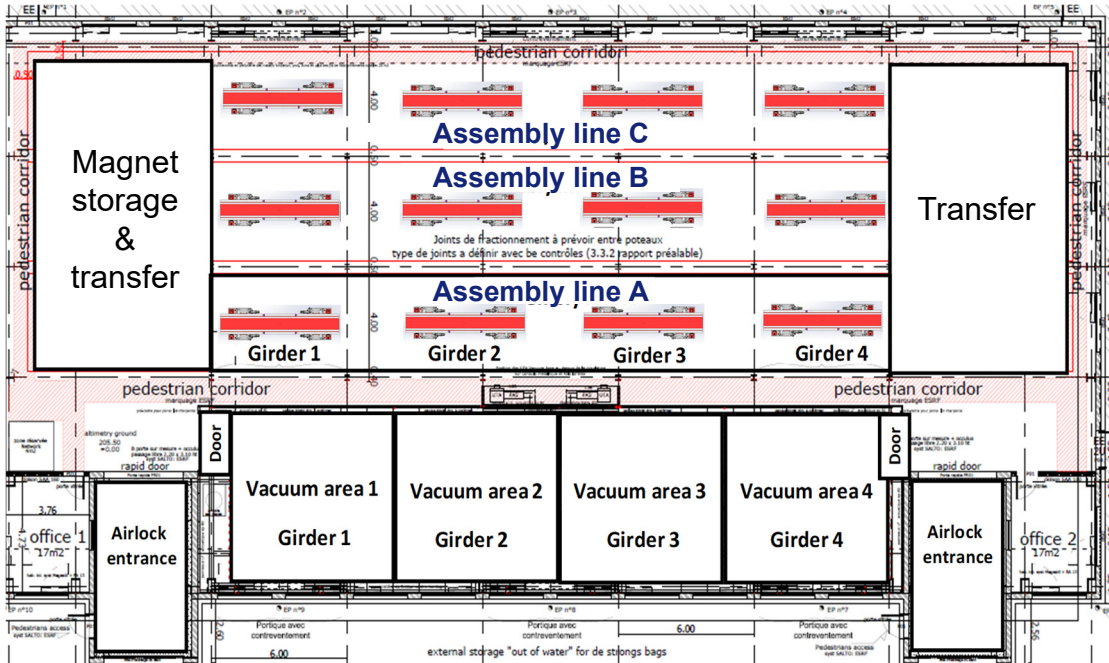

GIRDER ASSEMBLY IN FULL SWING



- Assembly building delivered in October 2017
- 3 assembly lines + 1 vacuum preparation line
- 3 to 4 girders assembled per week
- 37 girders among 128 are fully assembled (*end of April*)

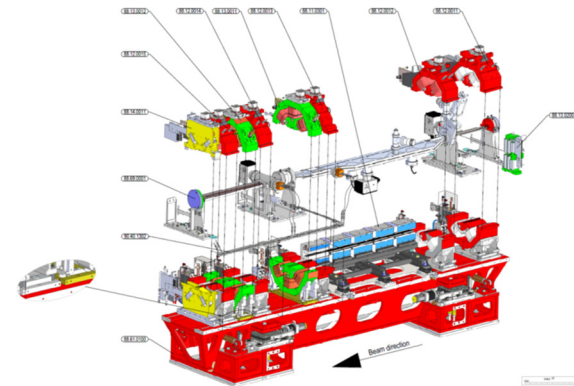

LOGISTICS & STORAGE



Storage and logistics are key issues for an upgrade



DISMANTLING + INSTALLATION: DEC 2018 – NOV 2019

Dec 2018

Nov 2019



DISMANTLING + INSTALLATION: DEC 2018 – NOV 2019

Dec 2018

Nov 2019

Dismantling

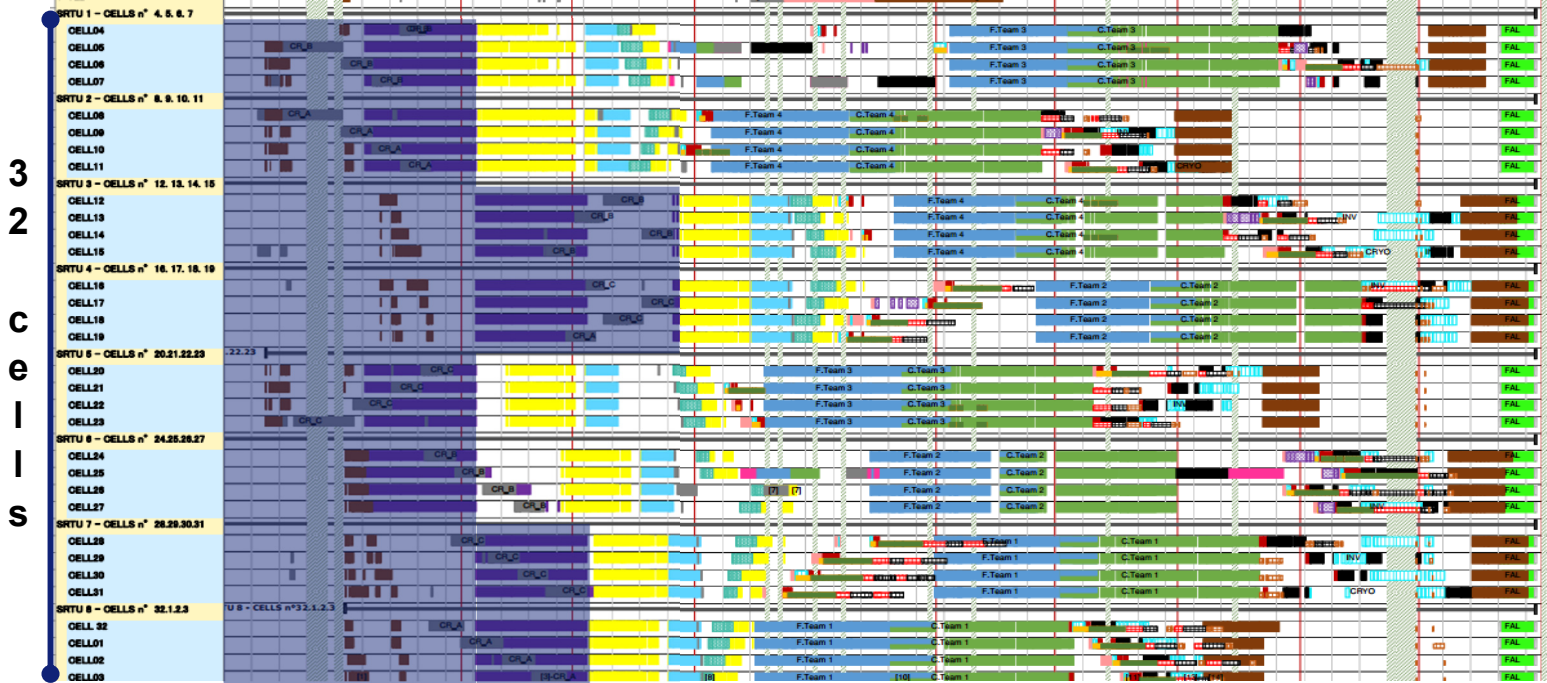

DISMANTLING + INSTALLATION: DEC 2018 – NOV 2019

Dec 2018

Nov 2019

Dismantling

Civil works

3
2
C
E
I
S

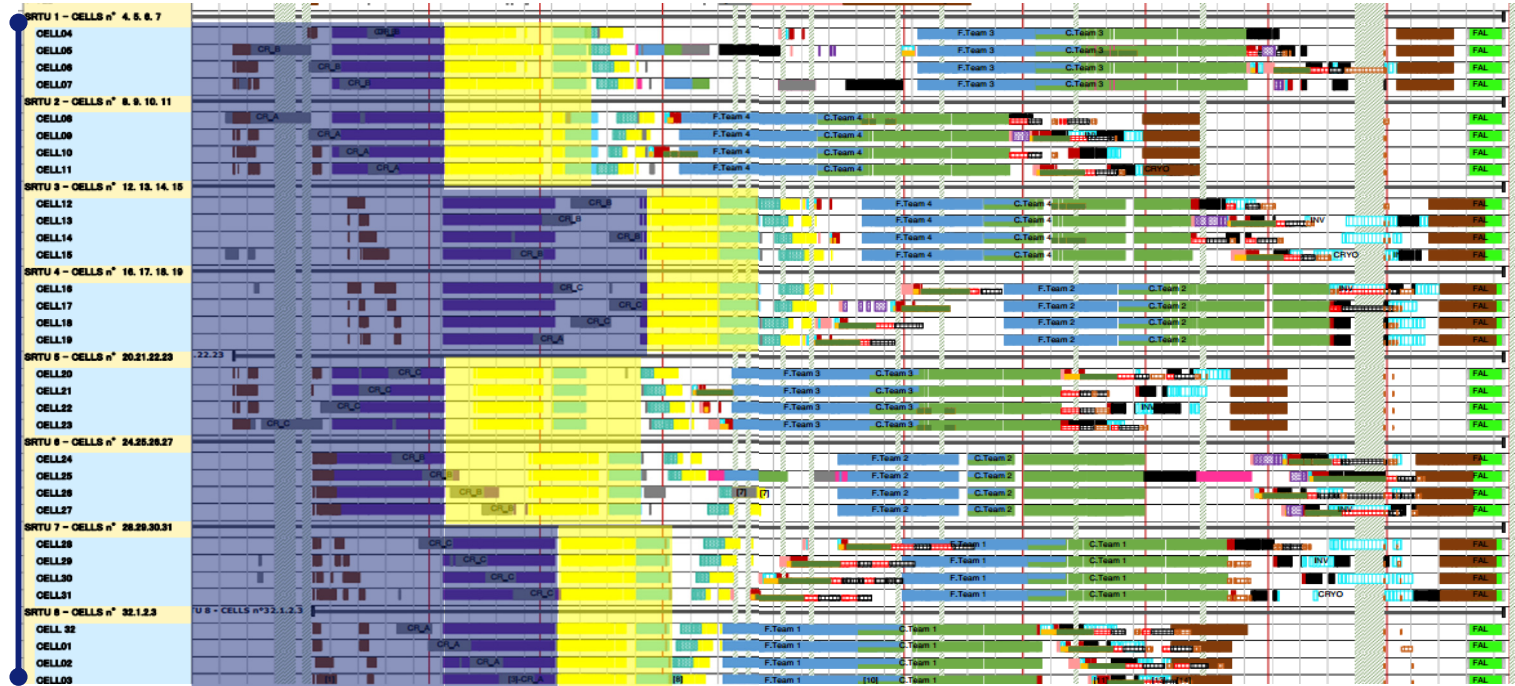

Old machine storage building for radioprotection control

DISMANTLING + INSTALLATION: DEC 2018 – NOV 2019

Dec 2018

Nov 2019

Dismantling

Civil works

Girder entry
Vacuum connection

3
2
C
E
I
S

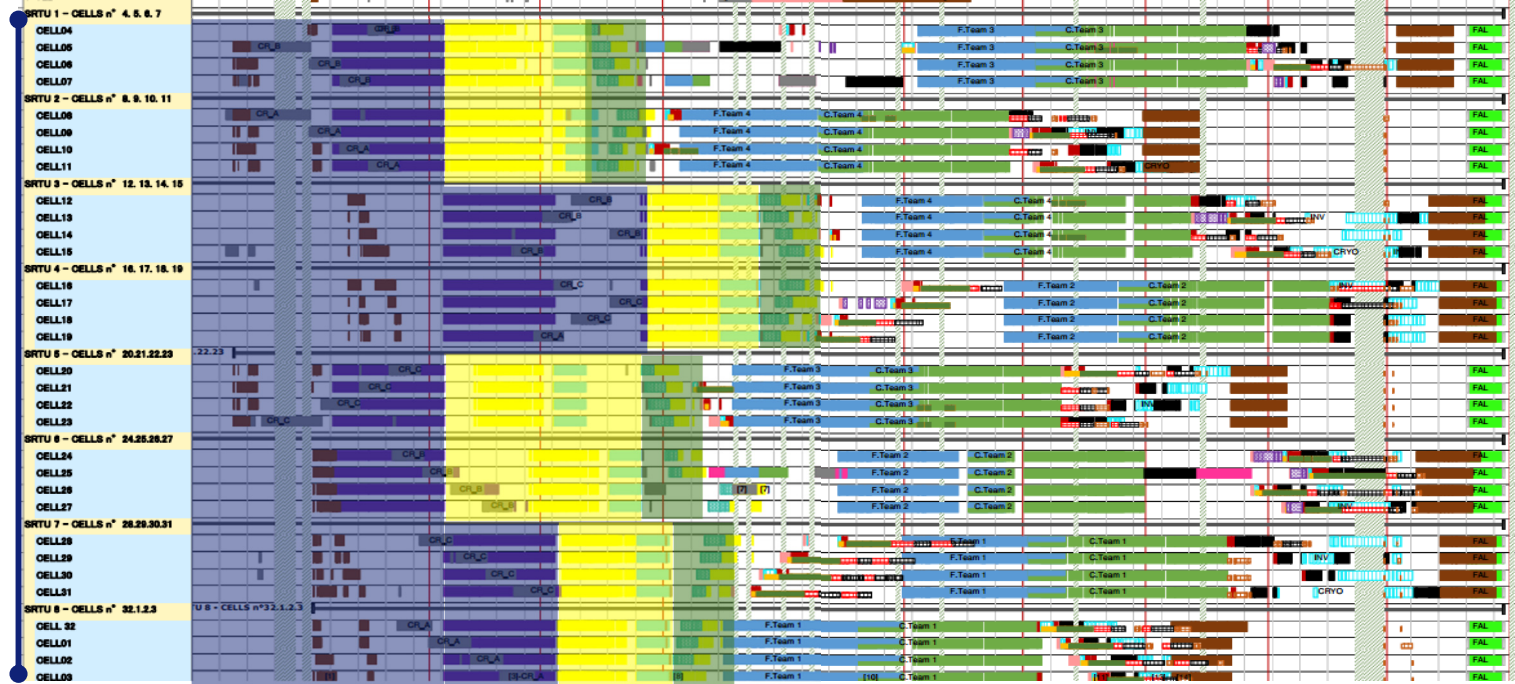

DISMANTLING + INSTALLATION: DEC 2018 – NOV 2019

Dec 2018

Nov 2019

Dismantling

Civil works

Girder entry
Vacuum connection

Piping

3
2
C
E
I
S

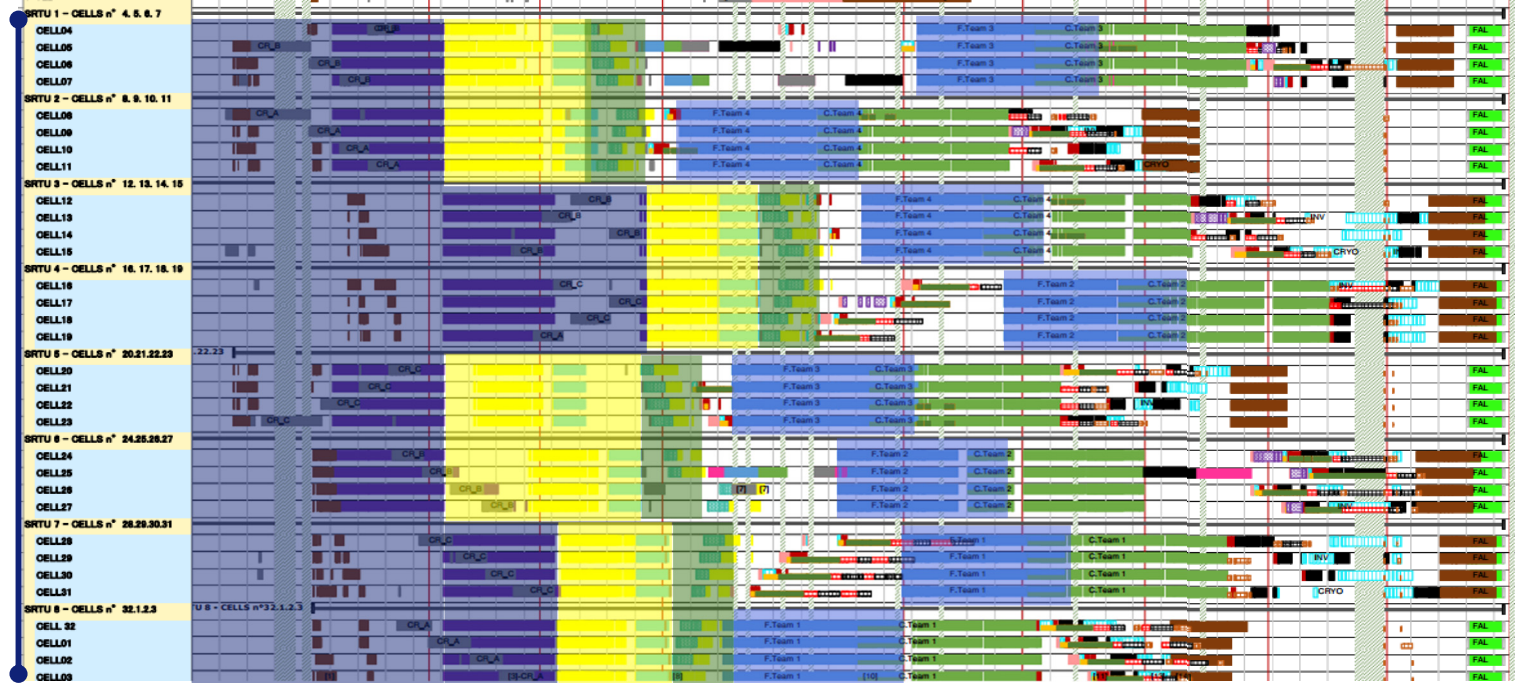

DISMANTLING + INSTALLATION: DEC 2018 – NOV 2019

Dec 2018

Nov 2019

Dismantling

Civil works

Girder entry
Vacuum connection

Piping
Cabling

3
2
C
E
I
S

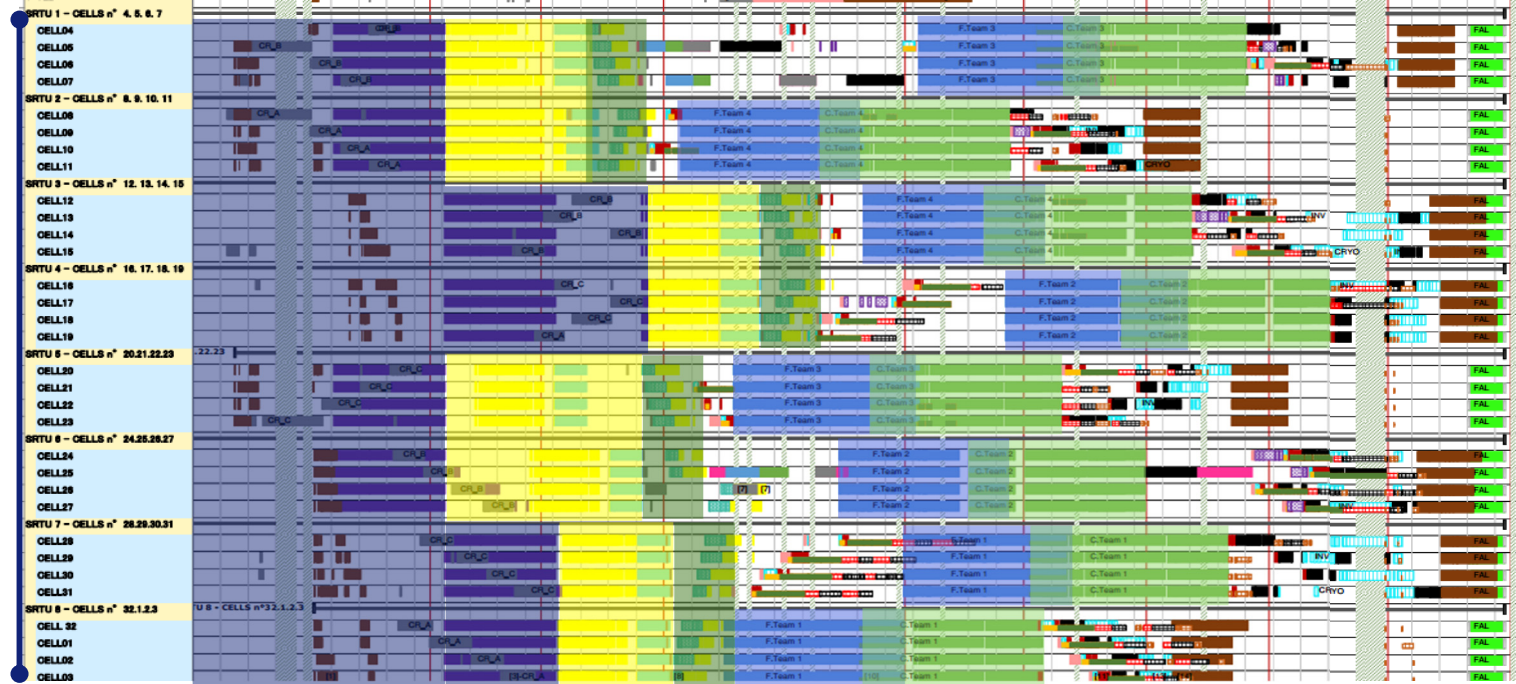

DISMANTLING + INSTALLATION: DEC 2018 – NOV 2019

Dec 2018

Nov 2019

Dismantling

Civil works

Girder entry
Vacuum connection

Piping
Cabling

FE+Bakeout
+Straights Sections

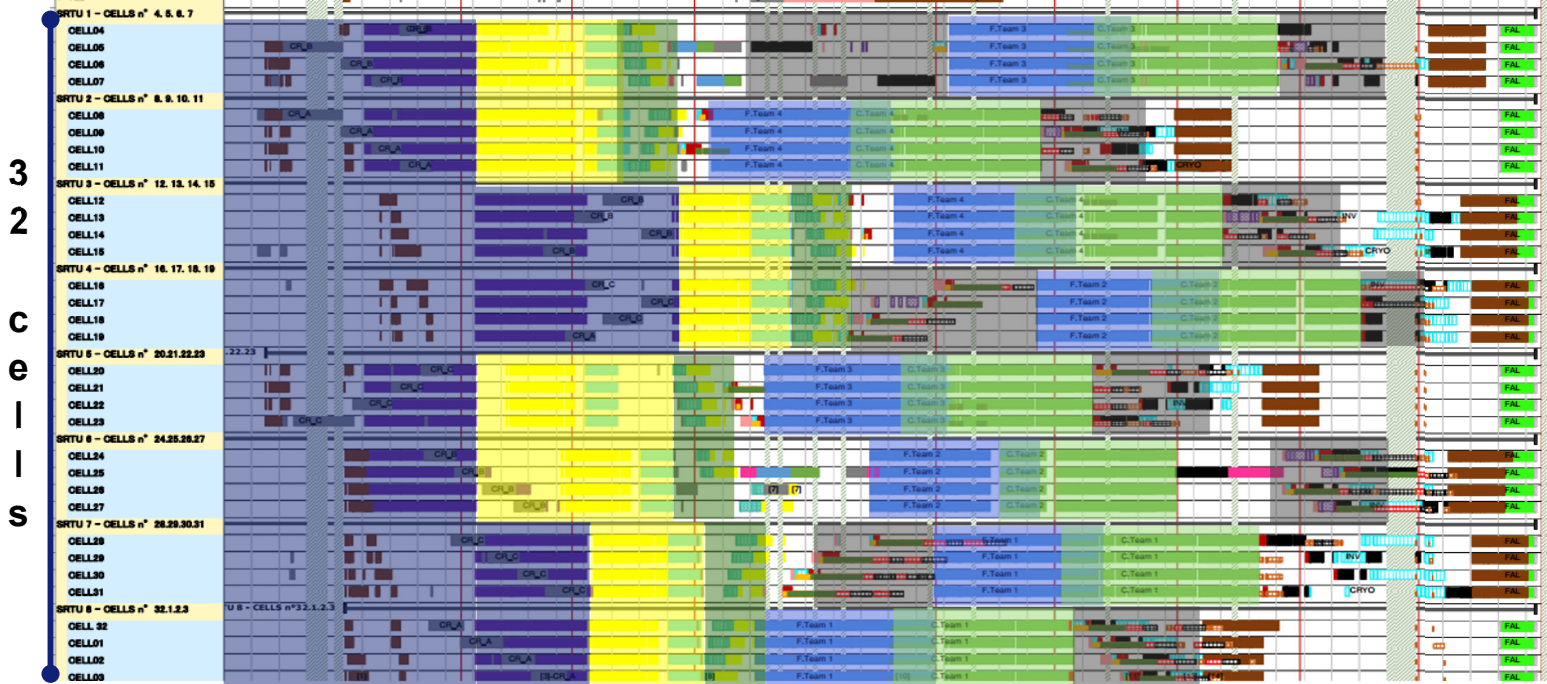

DISMANTLING + INSTALLATION: DEC 2018 – NOV 2019

Dec 2018

Nov 2019

Dismantling

Civil works

Girder entry
Vacuum connection

Piping
Cabling

FE+Bakeout
+Straights Sections

PSS test

3
2
C
e
l
l
i
s

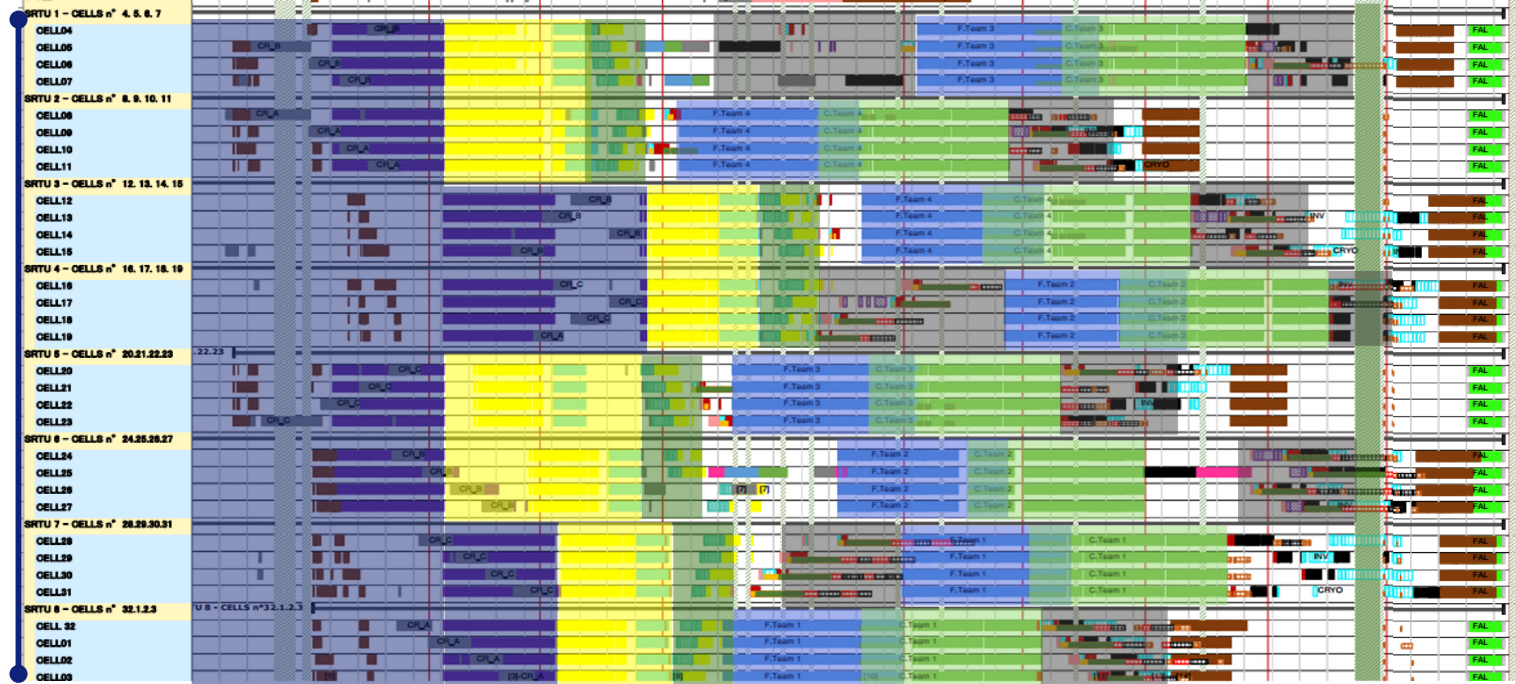

DISMANTLING + INSTALLATION: DEC 2018 – NOV 2019

Dec 2018

Nov 2019

Dismantling

Civil works

Girder entry
Vacuum connection

Piping
Cabling

FE+Bakeout
+Straights Sections

PSS test
Equipment test

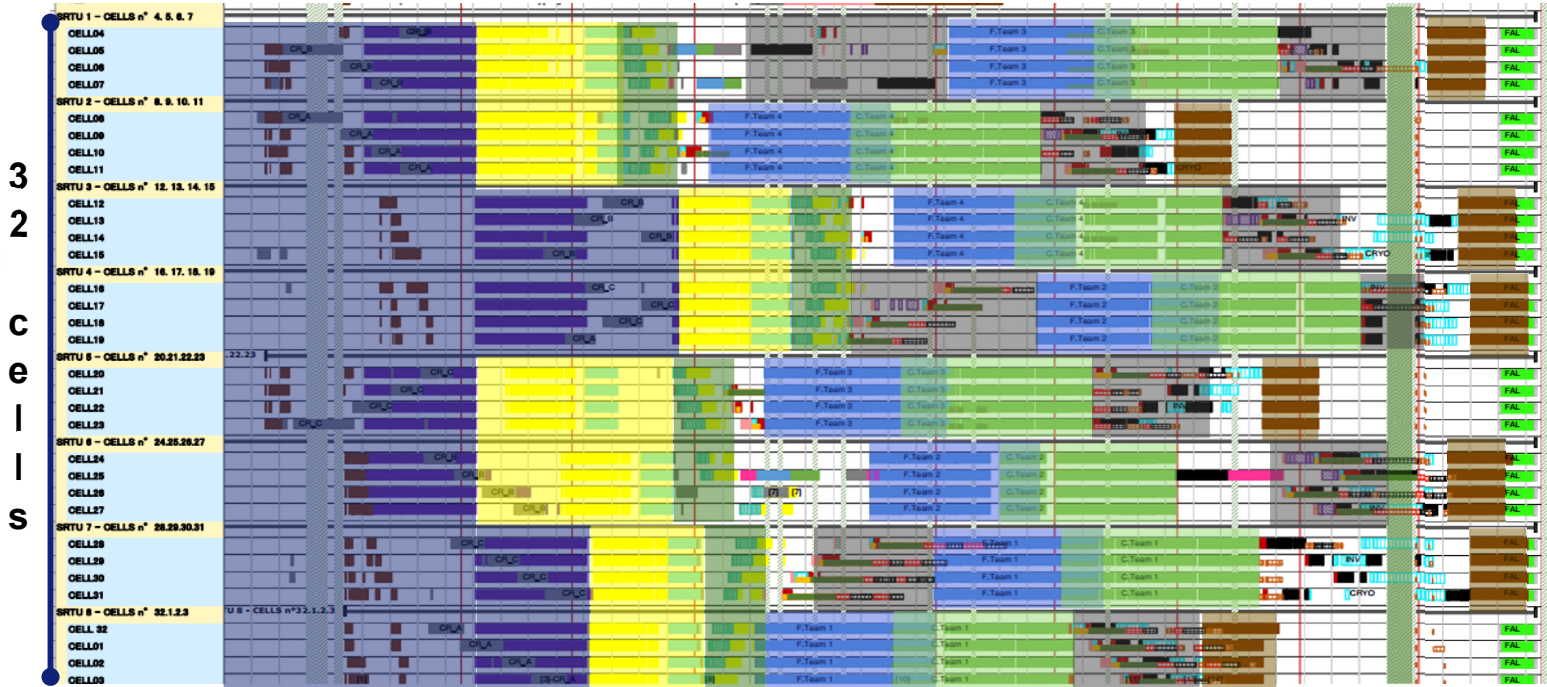

DISMANTLING + INSTALLATION: DEC 2018 – NOV 2019

Dec 2018

Nov 2019

Dismantling

Civil works

Girder entry
Vacuum connection

Piping
Cabling

FE+Bakeout
+Straights Sections

PSS test
Equipment test
Alignment

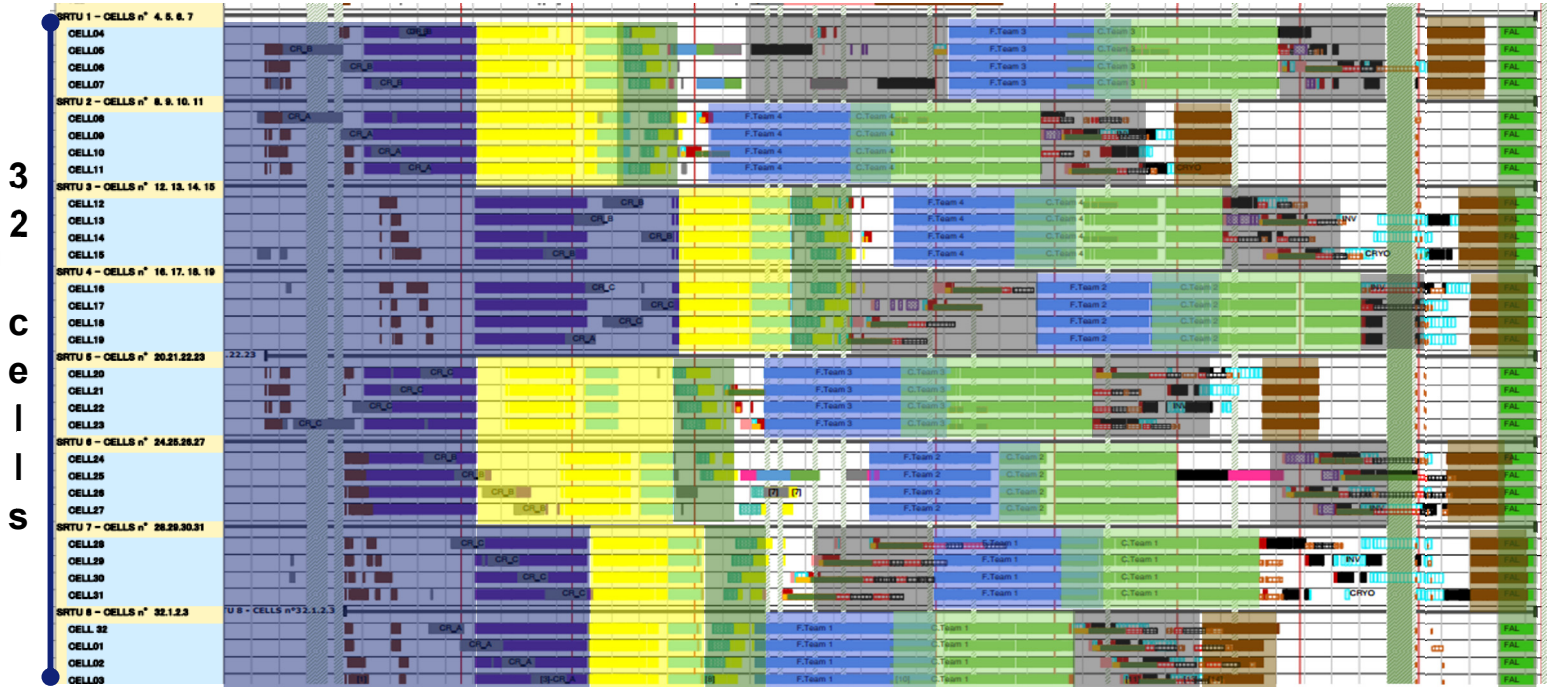

+ all the activities in the technical areas

SR INSTALLATION – ENTERING GIRDERS

Assembled girders (12T) are too heavy for the 3 overhead cranes (6.3T)

3 entry points with fixed gantries to lift the girders above the tunnel wall

2 modules to move the girders inside the tunnel for final installation

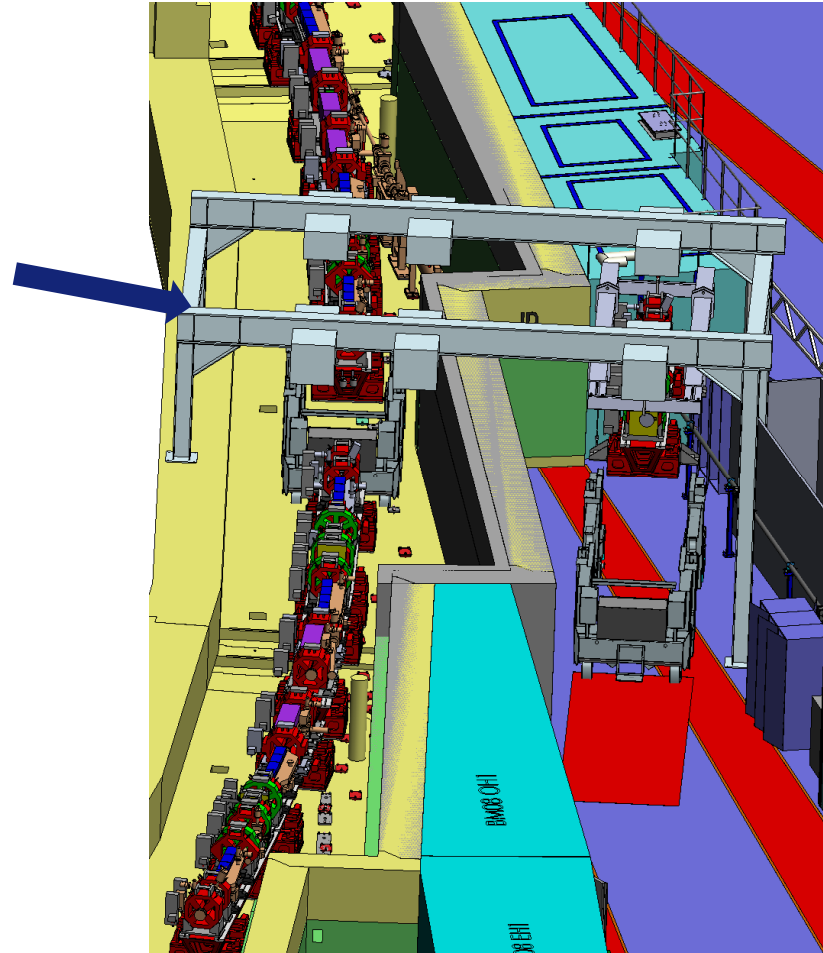

➤ Tests before commissioning:

All equipment must be available and tested for both Hardware, Control software

The new SR will benefit from the existing control system (TANGO) and from the running infrastructure

Avoid any modification of equipment tested and running before the shutdown:

- New timing system: should be operational before the shutdown
- BPMs: 60% of the hardware is kept, new hardware already installed and tested, software unchanged,
- Loss monitors: installed and operational to get references

High level commissioning procedures tested on the accelerator simulator available from now on

The magnet power supply system (*completely new architecture*) is the most critical element

➤ Accelerator commissioning:

Allocated time : 3 months, starting: Monday November 18th, 2019

- Month 1 : debugging of equipment and software, 1st turn, initial tuning at low current
- Month 2 : Current ramping, finer optics tuning
- Month 3: Contingency, stabilisation of the beam delivery

2 shutdowns are scheduled in that period for heavy interventions and the installation of the sources for bending magnet beamlines (*Single-pole magnet, Two-pole wigglers, Three-pole wiggler*)

CONCLUSION

- **EBS project running in parallel with ESRF operation**
 - **No impact on user operation**
 - **Continuation of the development of the existing machine**
(injector upgrade, top-up, cryo-undulators,...)
- **Project execution progression as of today:**
 - **Engineering Design completed**
 - **Procurement in full swing**
 - **Delivery of main components within schedule**
 - **Mock-up cell completed**
 - **Assembly in full swing**
 - **Dismantling/installation/commissioning in preparation**
 - **At this stage of the project, no show stopper identified.**

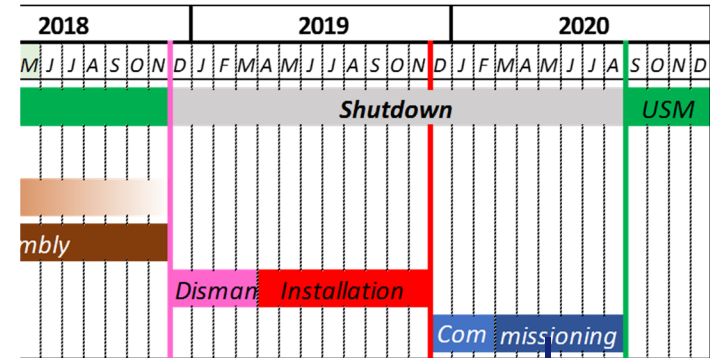

MANY THANKS FOR YOUR ATTENTION

Posters at IPAC'18

WEPMK009 Status of the ESRF-EBS Magnets

THPMF017 Operation Improvements and Emittance Reduction of the ESRF Booster

THPMF019 ESRF-EBS Lattice Model with Canted Beamlines

THPMF021 ESRF Operation Status

