



# **A PROPOSAL FOR COHERENT HARD X-RAY GENERATION BASED ON TWO-STAGE EEHG**

Zhentang Zhao

Shanghai Institute of Applied Physics, Chinese Academy of Sciences

IPAC'18, the 9th International Particle Accelerator Conference

Vancouver Canada, April 29-May 4, 2018

# Outline

- Introduction
- Recent experimental results of EEHG at SXFEL
- Two-linac based two-stage EEHG
- Double-bunch based two-stage EEHG
- A proposal for Testing cascaded EEHG at SXFEL
- Summary

# Introduction: Development of X-ray FEL

## First lasing of hard x-ray FEL

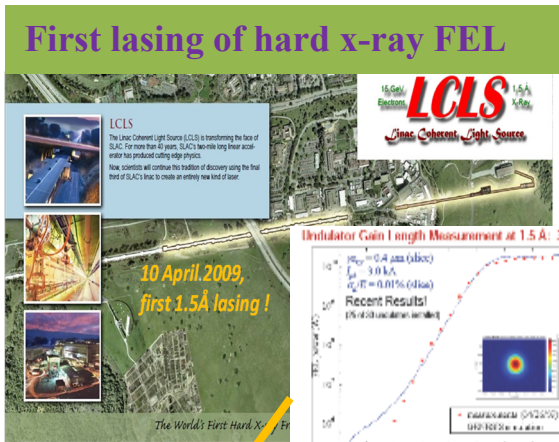

**LCLS**  
The Linac Coherent Light Source (LCLS) is transforming the face of SLAC. For more than 40 years, SLAC's been making linear accelerators for precision testing of physics. Now, scientists will continue this tradition of discovery using the full force of SLAC's linac to create an entirely new kind of laser.

**10 April 2009, first 1.5Å lasing!**

**Recent Results!**  
 $I_{ph} = 0.4 \mu\text{A}$  (dotted)  
 $I_{ph} = 3.0 \mu\text{A}$  (solid)  
 $\epsilon_1/\epsilon_2 = 0.01\%$  (dotted)  
 Recent Results! (5% of 2009 lasing data, simulated)

**Undulator Gain Length Measurement at 1.5 Å: 3.3 m**

*The World's First Hard X-ray FEL*

## Demonstration of hard x-ray self-seeding

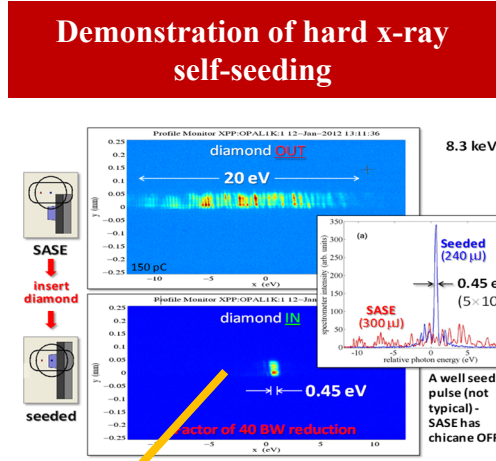

**8.3 keV**

**diamond OUT**  
20 eV  
150 pC

**diamond IN**  
0.45 eV  
factor of 40 BW reduction

**SASE (300 μJ)**  
Seeded (240 μJ)  
0.45 eV ( $5 \cdot 10^{-5}$ )

A well seeded pulse (not typical) - SASE has chicane OFF

## Two-color FEL: time and spectral control of the FEL

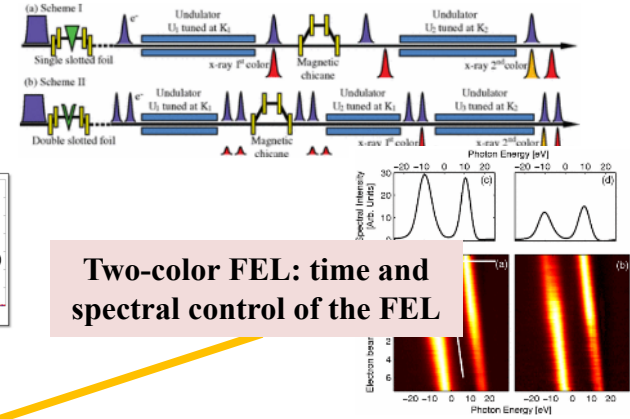

(a) Scheme I: Single slotted foil, Undulator  $U_1$  tuned at  $K_1$ , x-ray 1<sup>st</sup> color, Magnetic chicane, Undulator  $U_2$  tuned at  $K_2$ , x-ray 2<sup>nd</sup> color.

(b) Scheme II: Double slotted foil, Undulator  $U_1$  tuned at  $K_1$ , x-ray 1<sup>st</sup> color, Magnetic chicane, Undulator  $U_2$  tuned at  $K_1$ , x-ray 2<sup>nd</sup> color.

**Spectral Intensity [arb. Units]**  
Photon Energy [eV]

**Electron beam**  
Photon Energy [eV]



## SACLA Lased



**SACLA RIKEN**

Announcement  
**SACLA Lased**

At 16.1 nm (Jan 7, 2011), we accomplished "lasing" with SACLA, our new hard X-ray free electron laser facility. Construction of SACLA began in 2006 as part of Japan's Key Technology of National Importance program. We appreciate your support in helping us to achieve this milestone. We will do our best to live up to your expectations.

## FERMI: First fully coherent x-ray FEL based on external seeding

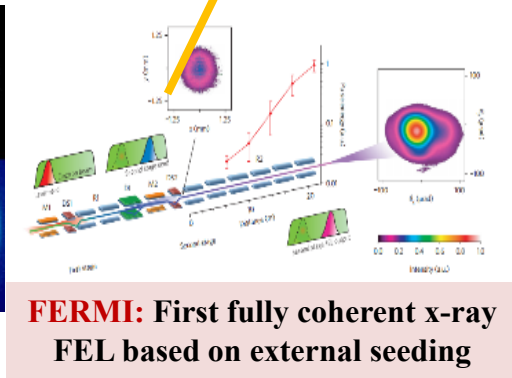

**FERMI**



**European XFEL: Superconducting linac based FEL**

- PAL-XFEL
- SwissFEL
- European XFEL
- FLASH-II
- SXFEL

Short wavelength, fully coherent, spectral control, high-repetition rate

# Applications of longitudinal coherent FEL

## Self-seeding

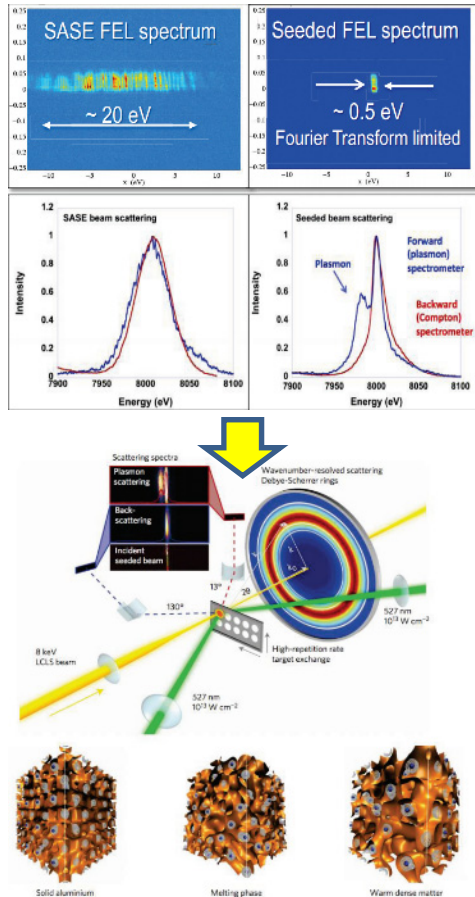

L. Fletcher et al., J. Instrum, 2013

## External seeding

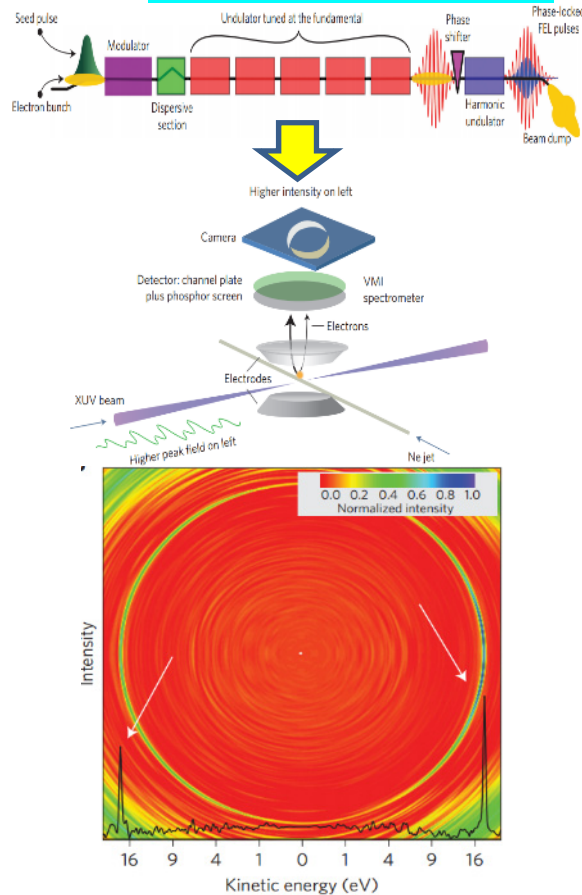

K. Prince et al., Nature Photonics, 2016.

## Multi-color

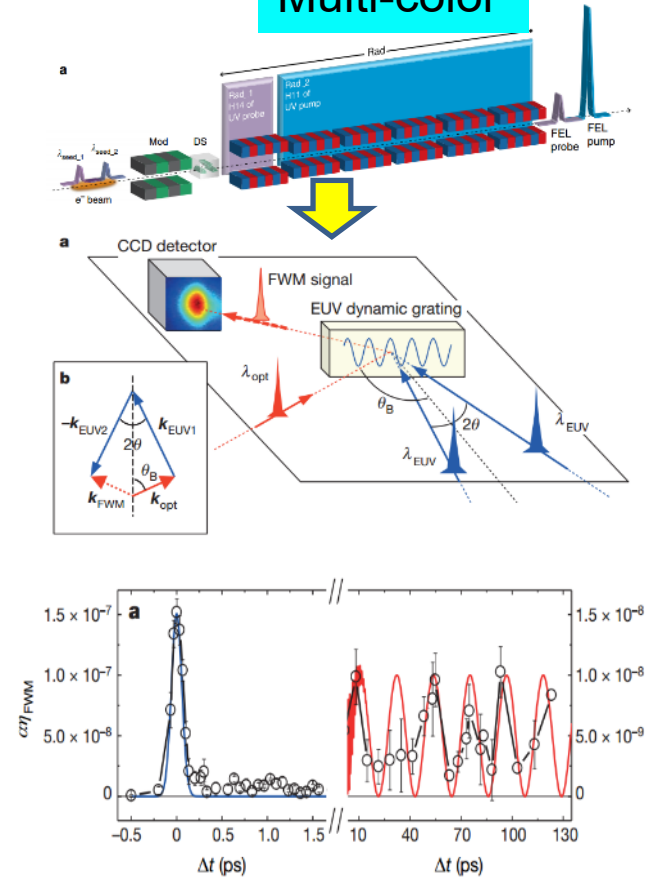

F. Bencivenga et al., Nature, 2015.

- User requirements for fully coherent, phase locked or multi-color radiation promote the development of fully coherent x-ray FEL.

# High-gain FEL facilities in China



**Shanghai Depp UV FEL (SDUV-FEL)**  
A test bench for novel FEL schemes



**Dalian Coherent Light Source (DCLS)**  
An EUV user facility (50 – 150 nm)



**Shanghai Soft X-ray FEL (SXFEL)**  
A test and user facility (2 – 10 nm)

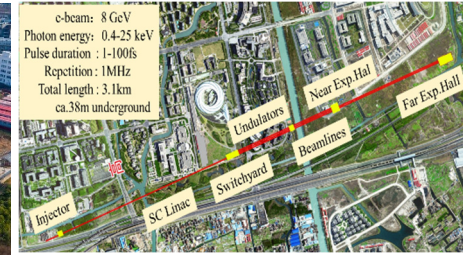

**Shanghai Coherent Light Facility (SCLF)**  
High repetition rate XFEL based on SC linac

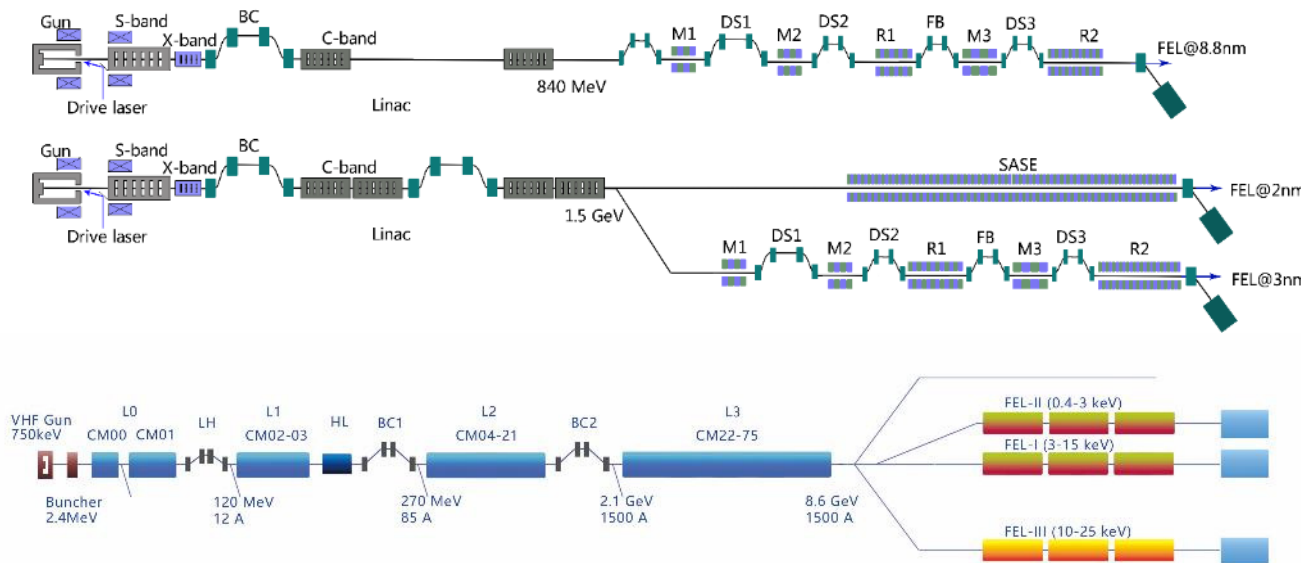

- ✓ SXFEL-TF&UF: EEHG, HGHG cascade, EEHG-HGGG cascade
- ✓ Coverage: 0.1-0.6 keV

- ✓ SCLF FEL-II: HGHG cascade, EEHG-HGGG cascade
- ✓ Coverage: 0.4-3keV

- Various external seeding schemes have been adopted as basic operation modes for FEL facilities in China
- Photon energy coverage from VUV to tender X-ray

# Echo-enabled Harmonic Generation

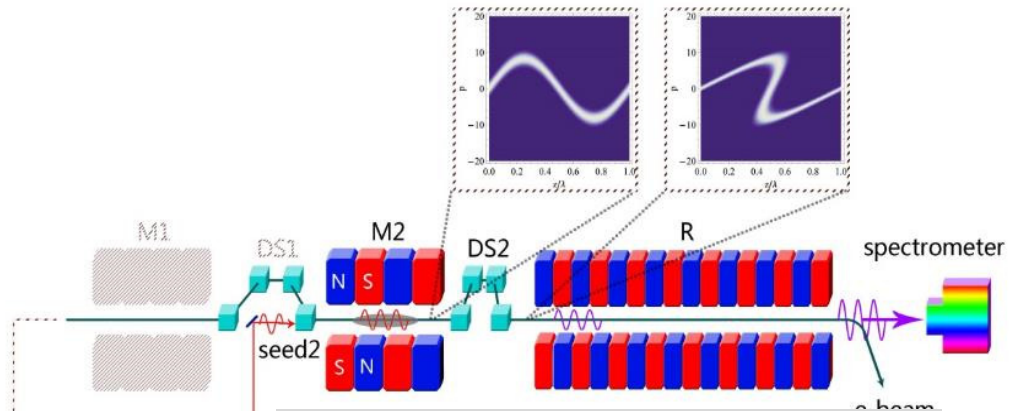

**HGHG:**  
L. H. Yu, PRA Vol.44, No.8 (1991)

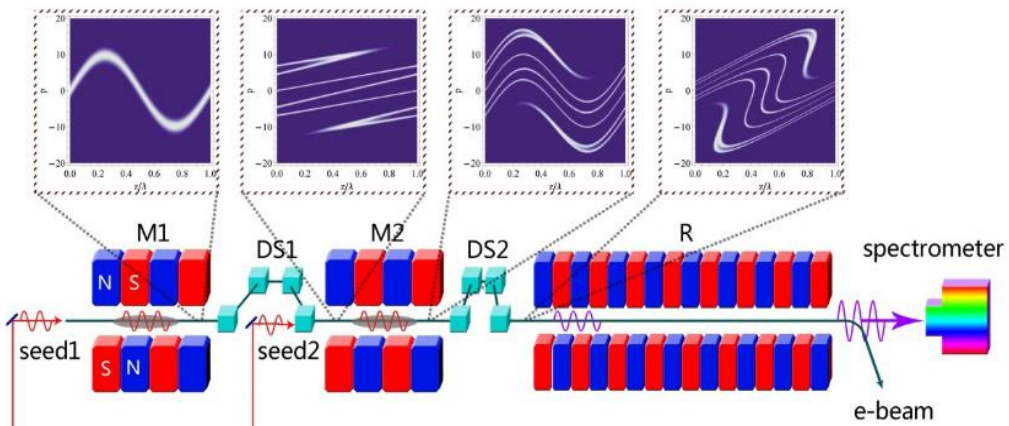

**EEHG:**  
G. Stupakov, PRL 102, 074801 (2009)  
D. Xiang, G. Stupakov, PRAB 12, 030702 (2009)

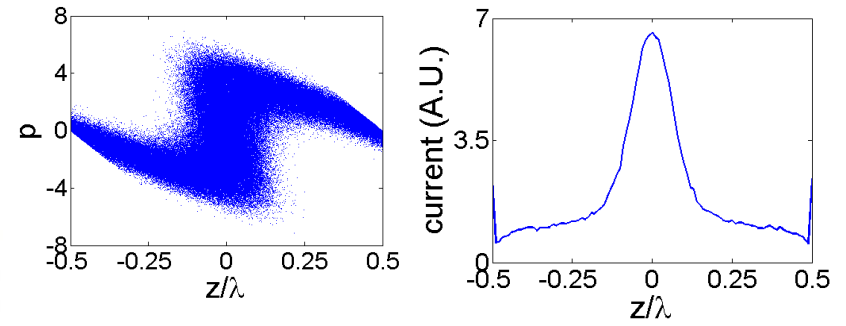

- Induced energy modulation at longer wavelength is changed into harmonic content after compression with a chicane.
- A selected harmonic is picked up with a succeeding undulator.
- Harmonic number is limited by laser induced energy spread.
- FERMI / DCLS / SXFEL.

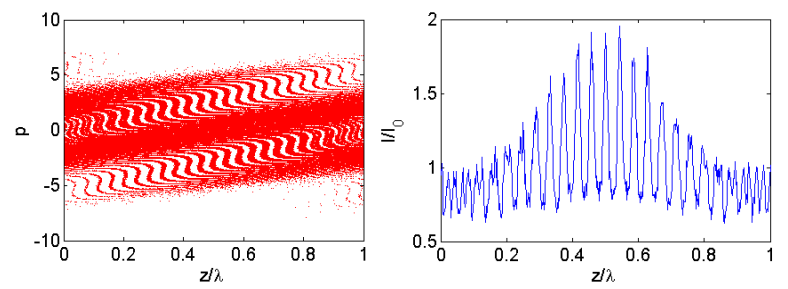

- over compression to generate energy bands
- spacing of bands defines harmonics
- **Commissioning at SXFEL/FERMI**

*High efficiency for bunching*

$$b_{\max} = \frac{0.39}{m^{1/3}}$$

# Demonstration the Principle of EEHG

Coherent signal of EEHG at 3<sup>rd</sup>, 7<sup>th</sup>, 15<sup>th</sup>, 75<sup>th</sup>  
(The shortest wavelength has been pushed to 32 nm!)

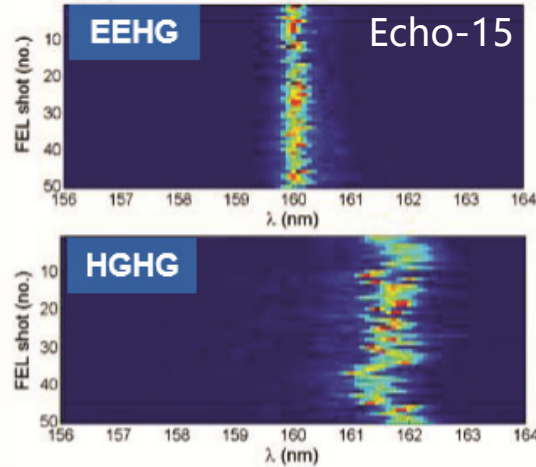
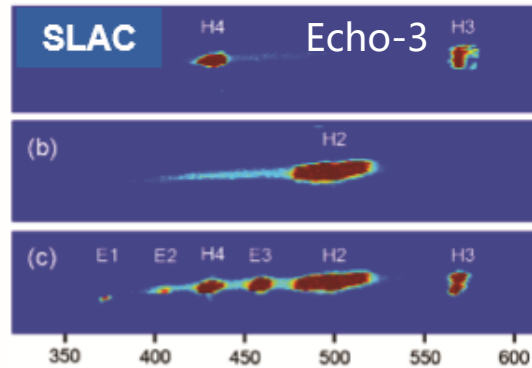

First lasing of EEHG@**350nm**  
(3<sup>rd</sup> harmonic of the seed)

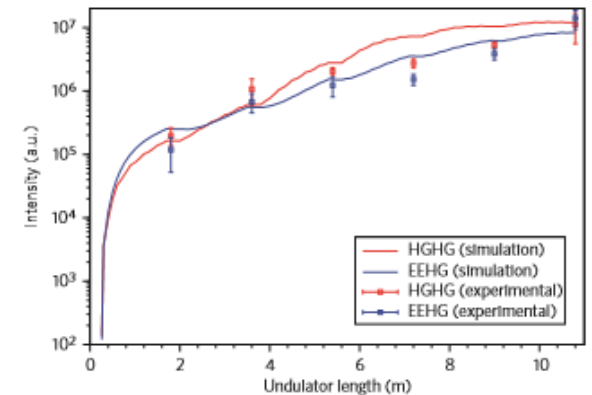
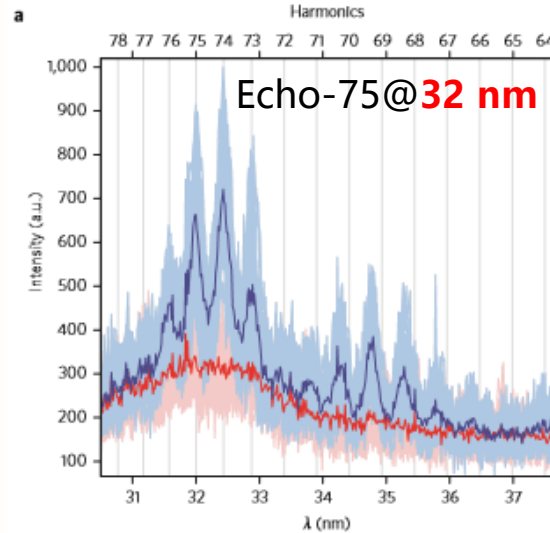
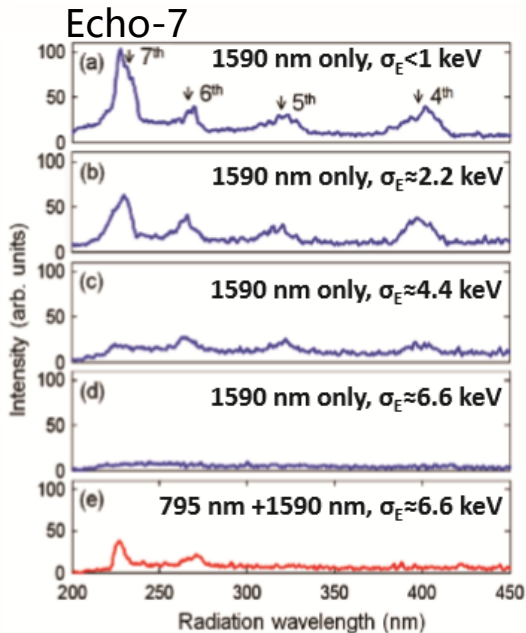
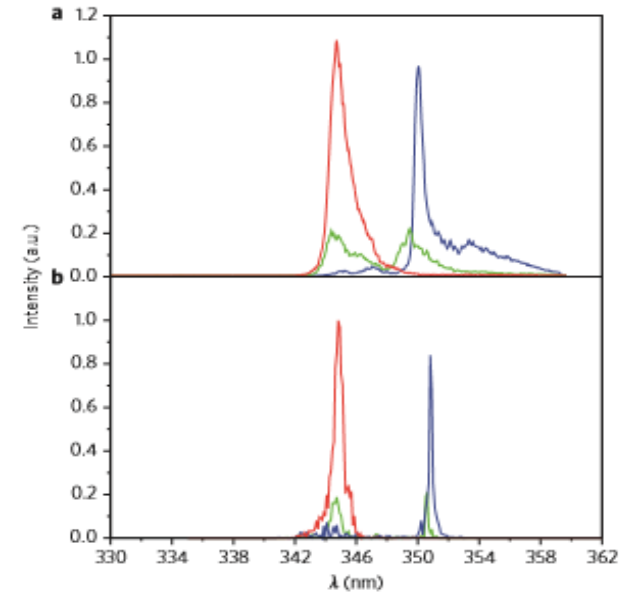

Xiang et al., PRL (2010), Xiang et al., PRL (2012), Hemsing et al., PRST-AB (2014), Hemsing et al., Nat. Photonics (2016)

Zhao et al., Nat. Photonics 6 (2012)

# Echo-30 Experiment at SXFEL (8.8 nm)

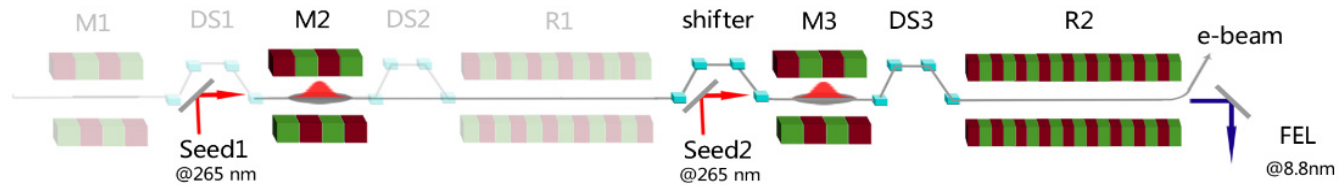

Layout for the echo-30 experiment at SXFEL

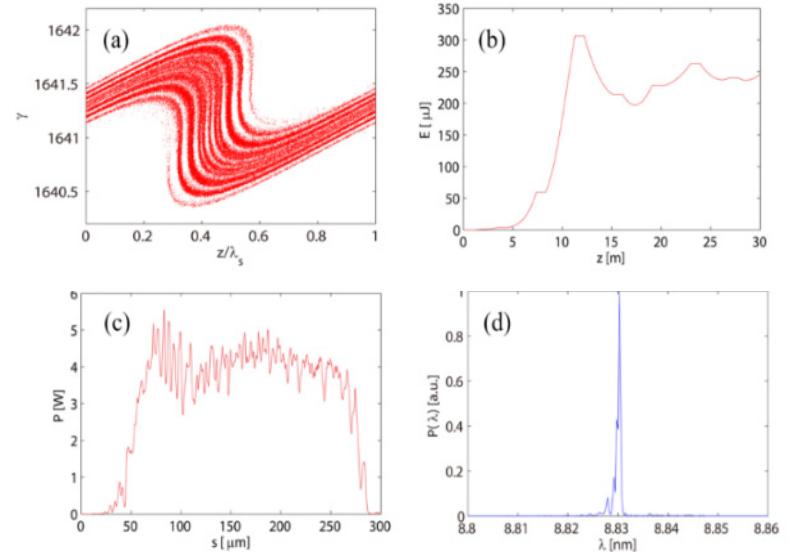

Results from s2e simulations

➤ **Coherent radiation of echo-30 (at 8.8 nm) has been obtained at SXFEL**

# First coherent x-ray from EEHG at SXFEL

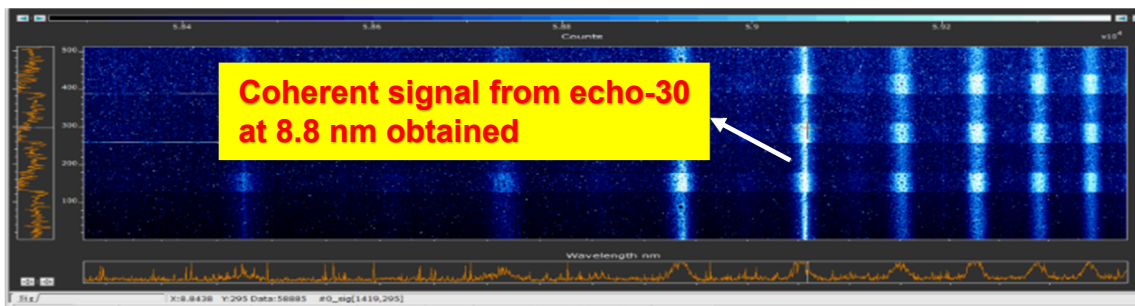
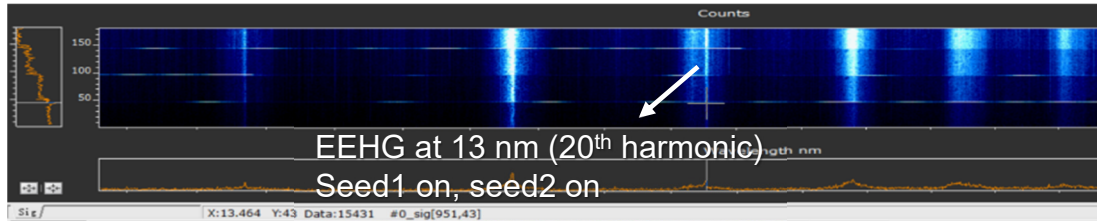
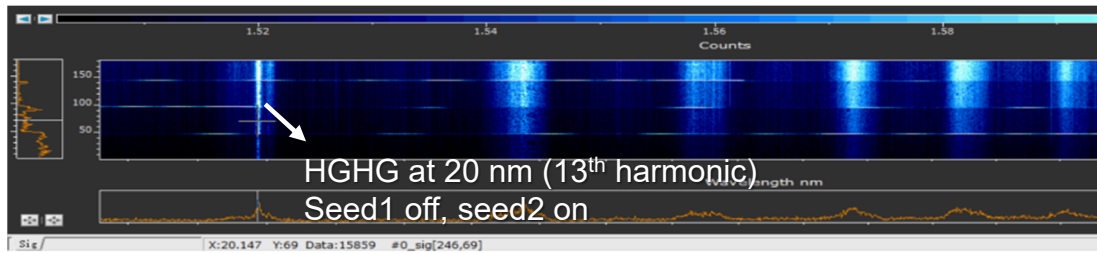
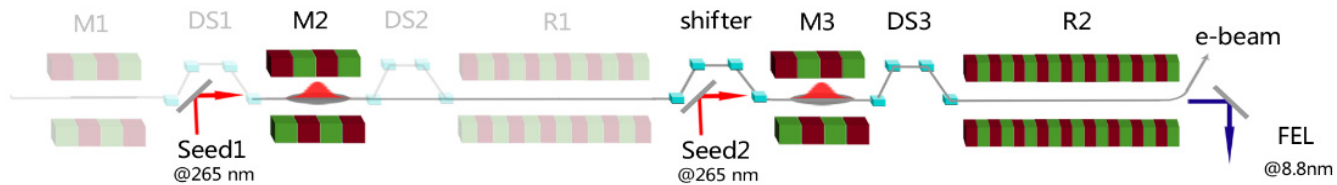

- Observed coherent signal for both HGHG and EEHG on the spectrometer
- It's hardly to see the coherent signal of HGHG for harmonic number larger than 16
- For EEHG it's easy to generate coherent signal at 20<sup>th</sup> and 30<sup>th</sup> harmonics of the seed by tuning the strength of the first chicane.

# EEHG Cascade for Higher Harmonics

## Two scenarios :

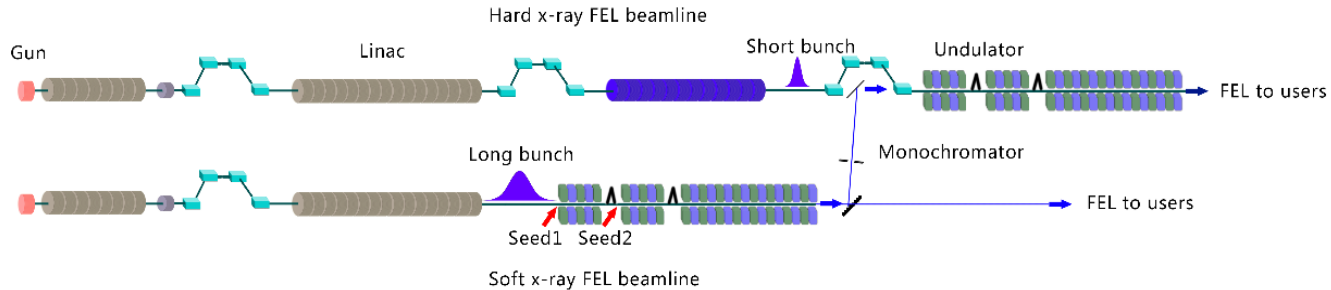

### 1. Two-linac based two-stage EEHG

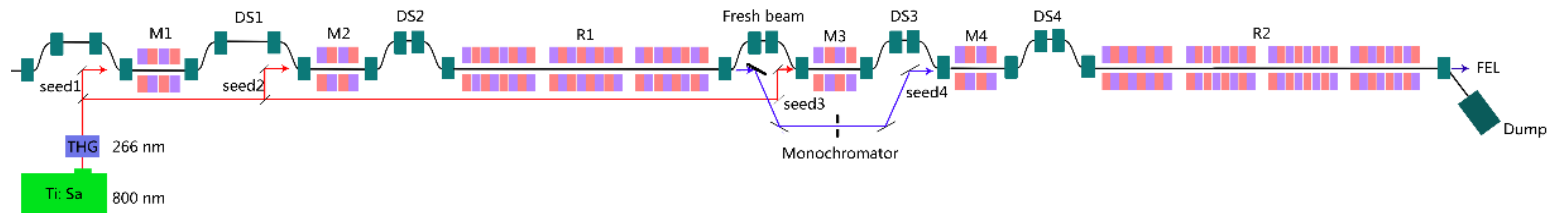

### 2. Double-bunch based two-stage EEHG

- **Long and electron short bunches:** Electron beams with quite different properties are separately used in each stage for improving the stability and peak power of the final output
- **Monochromator:** The noise amplification problem of harmonic cascading schemes may be solved by adding a soft x-ray monochromator between the two stages
- **A long soft x-ray EEHG pulse:** to seed a short electron bunch at two modulators

# Two-linac based two-stage EEHG

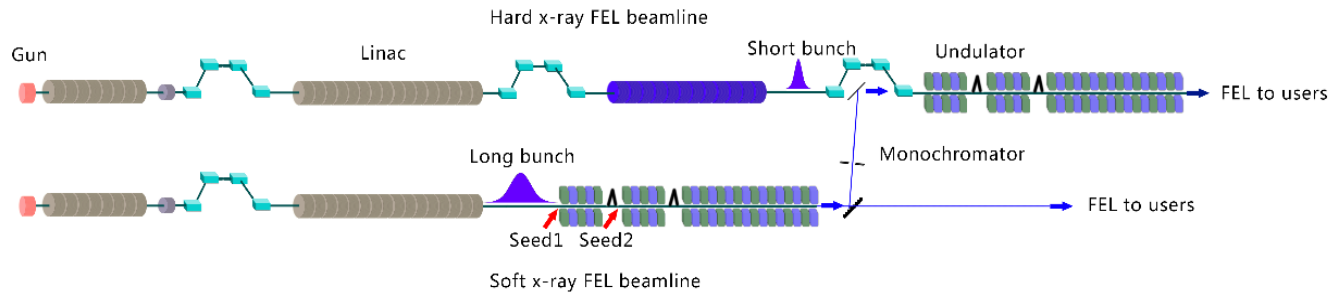

- This scheme combines the EEHG technique with the fresh bunch technique. It integrates the soft x-ray and hard x-ray FEL beamlines in one facility;
- Two electron bunches with quite different properties are generated by two linacs and separately used in two stages for improving the FEL performance:
  - ✓ The electron bunch used in the first stage is relative long to provide a long seed laser pulse for the second stage;
  - ✓ The electron bunch used in the second stage is short to maintain a stable overlapping at two EEHG modulator undulators.
- A soft x-ray monochromator between the two stages is employed, which may solve the noise amplification problem of harmonic cascading schemes;
- A long pulse to seed the short bunch at two modulators, it can reduce timing jitter effects on the final output, and it can be used for generating ultra-short radiation pulses with low charge mode at the second stage.

# Two-linac based two-stage EEHG

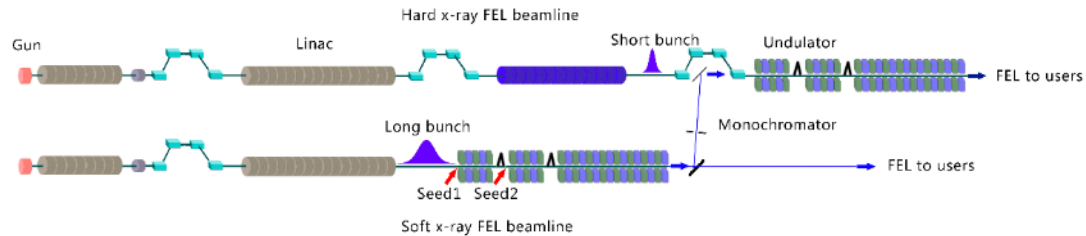

Main parameters and various jitters in the simulations

	The soft x-ray beamline (1 <sup>st</sup> stage)	The hard x-ray beamline (2 <sup>nd</sup> stage)
Beam energy/GeV	1.6	6
Peak current/kA	1	3
Normalized emittance/ $\mu\text{mrad}$	1	0.4
Slice energy spread	0.01%	0.01%
Bunch length/fs (FWHM)	500	80
Seed wavelength/nm	270	4.5
Seed powers/MW	200/500	800/800
Modulator period/cm	8	8
Modulator period numbers	20/10	15/10
Chicane strengths/mm	8.5/0.145	$4.7 \times 10^{-5}/3.26 \times 10^{-6}$
Radiator period/cm	2.5	1.8
Radiator gap/mm	7.2	5.2
Radiator length/m	14	40
Radiation wavelength/nm	4.5	0.15
Timing jitter of the drive laser/fs (rms)	50	50
Charge jitter (rms)	2%	2%
Phase error in the linac/degree (rms)	0.05	0.05
Voltage error in the linac (rms)	0.01%	0.01%
Relative timing jitter of the seed laser to the electron bunch/fs (rms)	50	/
Pulse energy fluctuation of the seed laser (rms)	5%	/

# Two-linac based two-stage EEHG

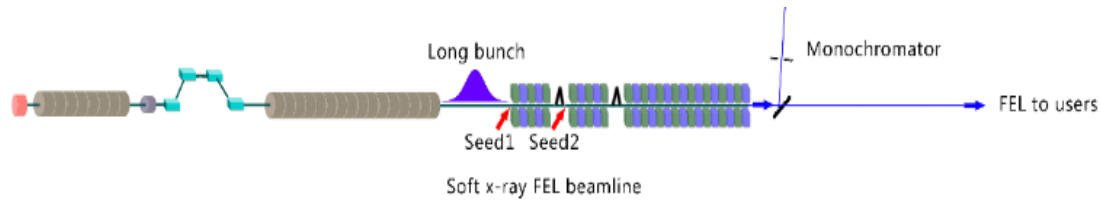

S2E simulation results for soft x-ray beamline:

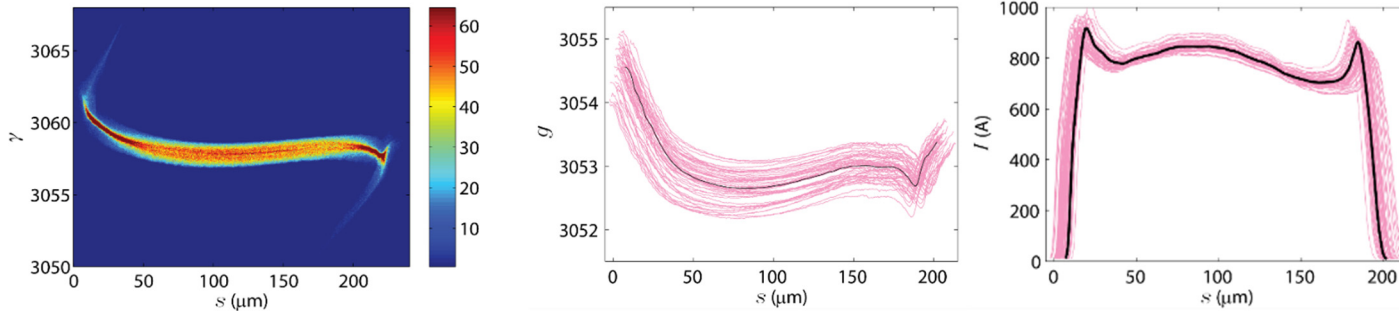

Electron beam with shot-to-shot energy jitter and current jitter

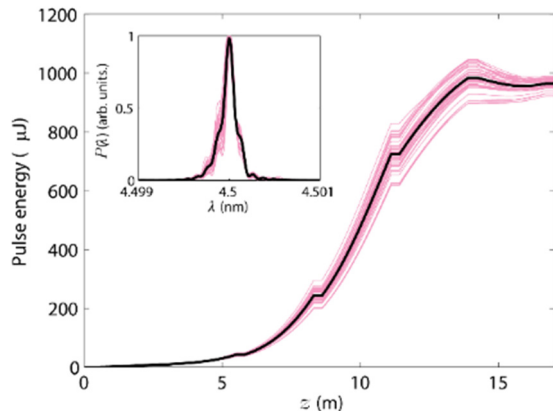

FEL gain curves in the radiator of the first stage. The insert plots the spectra of the FEL output

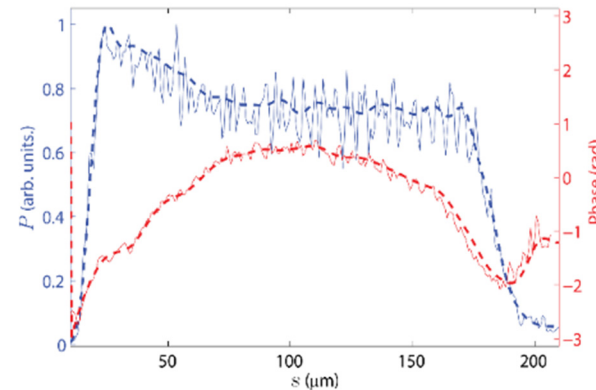

Longitudinal profile (blue) and phase (red) of the radiation pulse before (solid line) and after (dashed line) the monochromator.

# Two-linac based two-stage EEHG

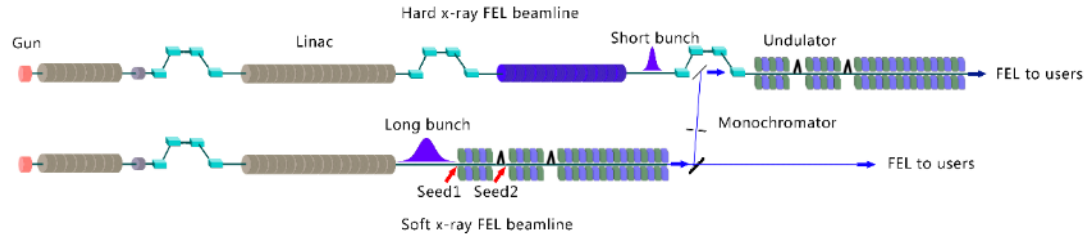

S2E simulation results for hard x-ray beamline:

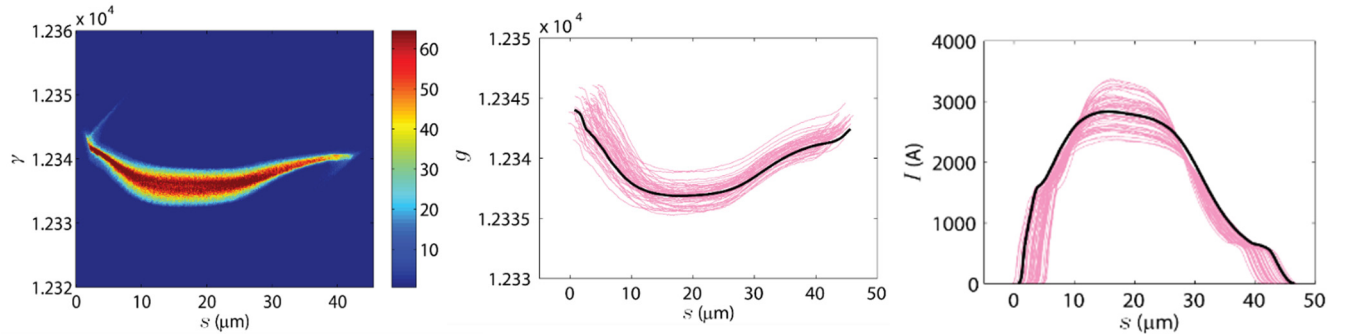

Electron beam with shot-to-shot energy jitter and current jitter

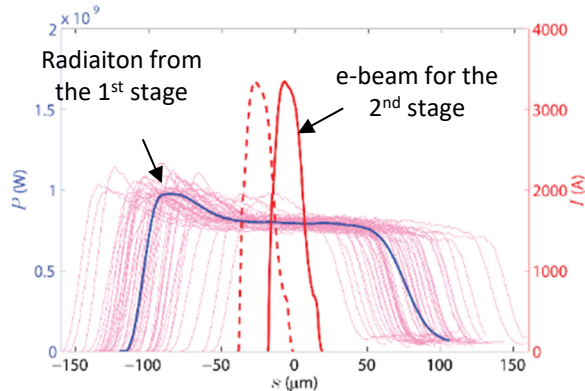

Realization of the energy modulations of EEHG with a single seed laser pulse in the second stage

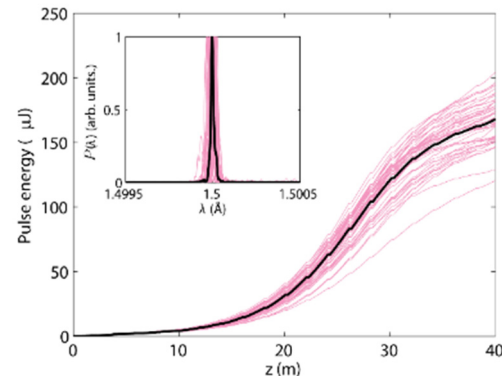

FEL gain curves in the radiator of the second stage. The insert plots the spectra of the FEL output

# Double-bunch two-stage EEHG

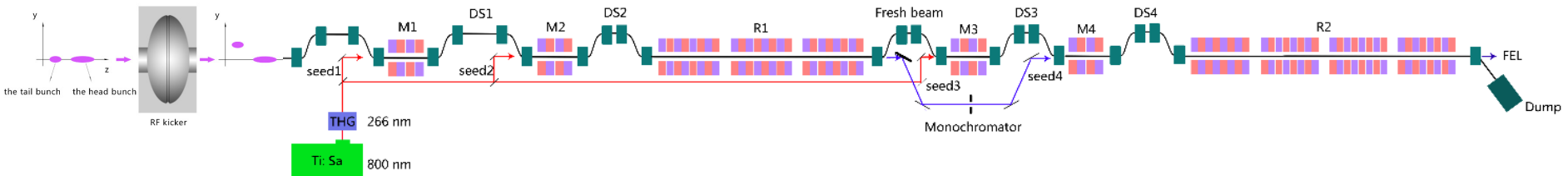

- Two different bunches are generated by two laser pulses, accelerated and compressed in the adjacent RF cycles of the linac, equivalent to having two separate concatenated seeded x-ray FELs.
- If needed, a RF kicker can be added into the upstream of undulators to provide a transverse deflection, and two adjacent bunches can be separately used in each stage.
- The soft x-ray pulse generated from the first EEHG stage is filtered through a monochromator and delayed by one RF cycle to seed the tail electron bunch in the second EEHG stage.
- The long FEL pulse is used to seed a short bunch at two modulators of 2<sup>nd</sup> EEHG stage, assuring the effective overlapping.

# Double-bunch based two-stage EEHG

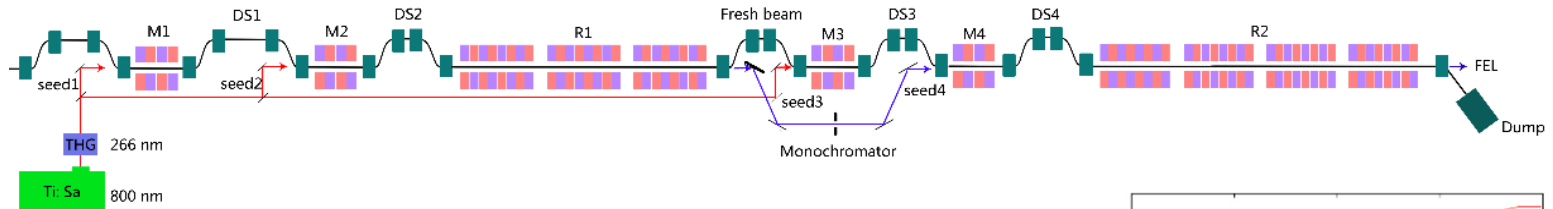

Main parameters in the simulations

	The soft x-ray beamline (1 <sup>st</sup> stage)	The hard x-ray beamline (2 <sup>nd</sup> stage)
Beam energy/GeV	8	8
Peak current/kA	3	3
Normalized emittance/ $\mu\text{mrad}$	1	0.4
Slice energy spread	0.01%	0.01%
Bunch length/fs (FWHM)	300	80
Seed wavelength/nm	266/266	266/4.43
Seed powers/GW	2/2	2/1.7
Modulator period/cm	16/16	16/6
Modulator period numbers	20/10	20/10
Chicane strengths/mm	8.5/0.145	$4.7 \times 10^{-5}/3.26 \times 10^{-6}$
Radiator period/cm	6	2
Radiator gap/mm	11.3	4.7
Radiator length/m	14	40
Radiation wavelength/nm	4.43	0.148
Repetition rate/kHz	1	1

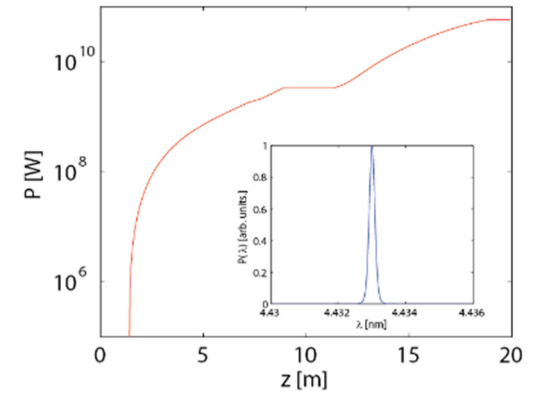

Simulation results for the first stage EEHG

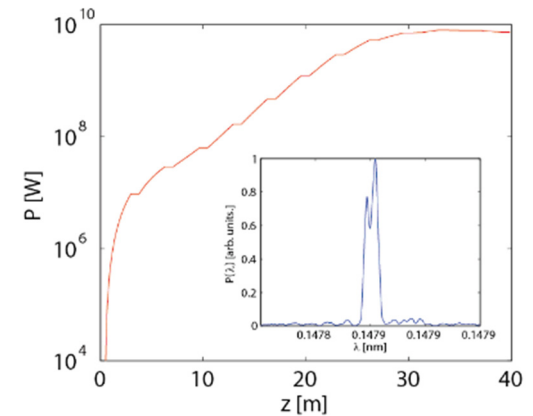

Simulation results for the second stage EEHG

# Double-bunch based two-stage EEHG

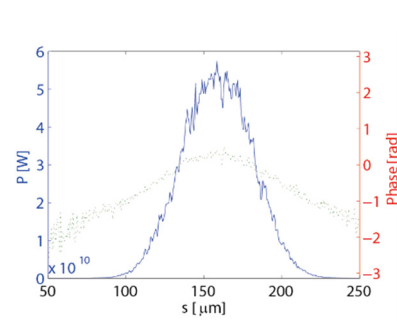

The FEL radiation pulse from 1<sup>st</sup> stage EEHG

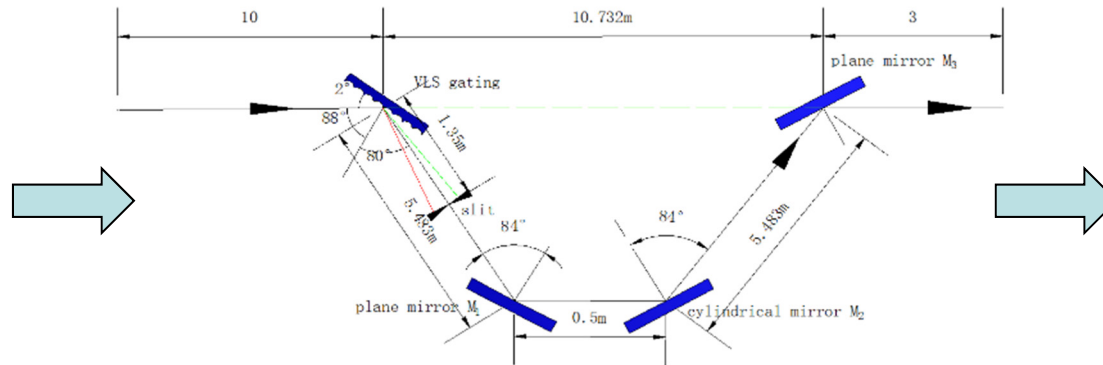

Soft x-ray monochromator

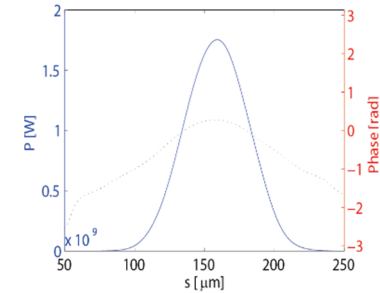

The seed laser pulse to 2<sup>nd</sup> stage EEHG

## Design parameters for the grating monochromator

parameter	Value (@1000eV)
Incidence angle	88°
Diffraction angle	80°
$D_0(cm)$	32919
$D_1(cm^2)$	489.41
$D_2(cm^3)$	16.25
$D_3(cm^4)$	0.43665
$R_m(m)$	190
$R_{sag}(cm)$	35
$f_{obj}(m)$	10
$f_{imag}(m)$	1.35
delay(cm)	25
$M_2$ radius	10.42

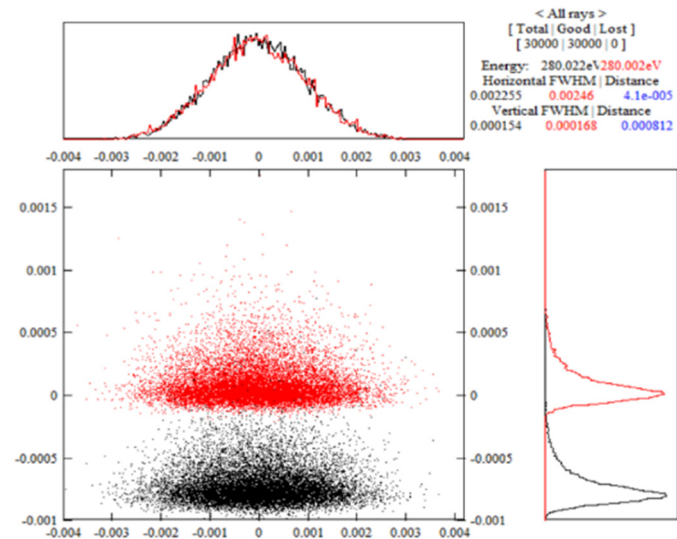

Calculation results of the resolution of the monochromator

# A Proposal for Testing cascaded EEHG at SXFEL

## CW-FEL Test facility for SCLF

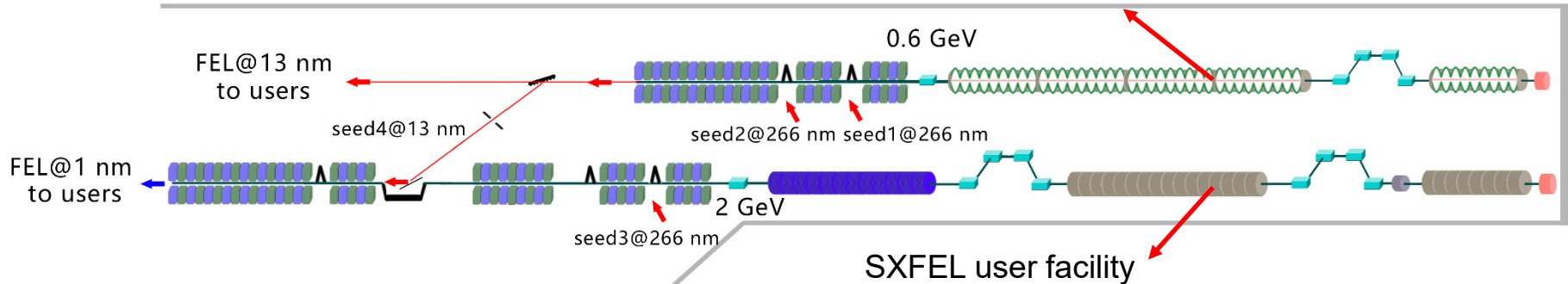

## SXFEL user facility

### Electron beam of CW-FEL Test Facility

Energy	600 MeV
Slice energy spread (rms)	60 KeV
Normalized emittance (rms)	1.5 mm-mrad
Charge	500 pC
Peak current	500 A
Rep rate	100 kHz

### Undulator

Period of modulators	5 cm
Seed laser wavelength	260 nm
Period of radiators	2.5 cm
FEL wavelength	13 nm (20 <sup>th</sup> harmonic)
FEL pulse length (FWHM)	1 ps
FEL peak power	300 MW
FEL average power	300 W

- As a test facility: testing superconducting techniques and new FEL principles
- As a user facility: providing high average-power radiation at ~13 nm

# Summary

- Single stage EEHG seems very promising for producing coherent soft x-ray generation.
- The first soft x-ray radiation from EEHG at 8.8 nm has been obtained at the SXFEL test facility.
- Two scenarios for cascaded EEHG have been proposed to generate fully coherent hard x-ray free electron laser.

***Thanks for your attention!***