

First Demonstration of Ionization Cooling in MICE

ILLINOIS INSTITUTE
OF TECHNOLOGY

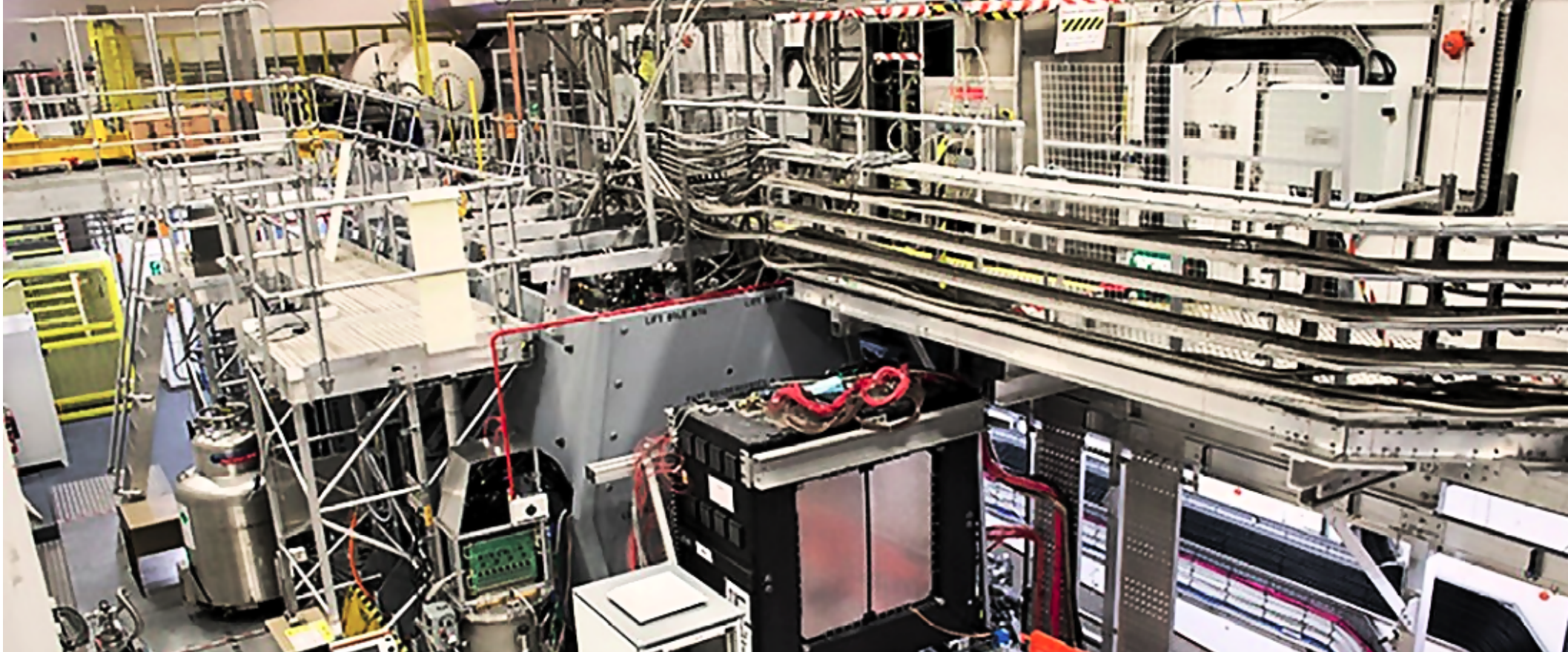

Tanaz Angelina Mohayai, for the MICE Collaboration
IPAC'18, Vancouver, Canada



Overview

- ▶ Motivation
- ▶ Muon Ionization Cooling
- ▶ Muon Ionization Cooling Experiment (MICE):
 - Collaboration, experimental site
 - Concept, single-particle nature, status
 - Beamline, detectors, optics
- ▶ Demonstration of Ionization Cooling:
 - Material studies
 - Ionization cooling
- ▶ Conclusion and Future Prospects

Overview

- ▶ Motivation
- ▶ Muon Ionization Cooling
- ▶ Muon Ionization Cooling Experiment (MICE):
 - Collaboration, experimental site
 - Concept, single-particle nature, status
 - Beamline, detectors, optics
- ▶ Demonstration of Ionization Cooling:
 - Material studies
 - Ionization cooling
- ▶ Conclusion and Future Prospects

Motivation

- **Muon Collider:**

- ★ Much less energy loss from synchrotron radiation ($m_\mu/m_e \sim 200$)
- ★ Compact \rightarrow cost-effective
- ★ Circular \rightarrow recycled beam \rightarrow high luminosity ($10^{34} \text{ cm}^{-2}\text{s}^{-1}$)
- ★ Clean multi-TeV collisions (e.g. $\mu^+ \mu^- \rightarrow H$)

- **Neutrino Factory** (shares same front-end with **Muon Collider**):

- ★ Background-free, well-characterized, intense ν_e/ν_μ from μ^- decay
- ★ Best ν oscillation sensitivity

- Challenge: large phase-space volume of muon beam (μ from **proton source**)

- Solution: **rapid beam cooling** via ionization energy loss – Muon Ionization Cooling

- Test: **Muon Ionization Cooling Experiment** as first demonstrator of ionization cooling

Overview

- ▶ Motivation
- ▶ Muon Ionization Cooling
- ▶ Muon Ionization Cooling Experiment (MICE):
 - Collaboration, experimental site
 - Concept, single-particle nature, status
 - Beamline, detectors, optics
- ▶ Demonstration of Ionization Cooling:
 - Material studies
 - Ionization cooling
- ▶ Conclusion and Future Prospects

Muon Ionization Cooling Principle

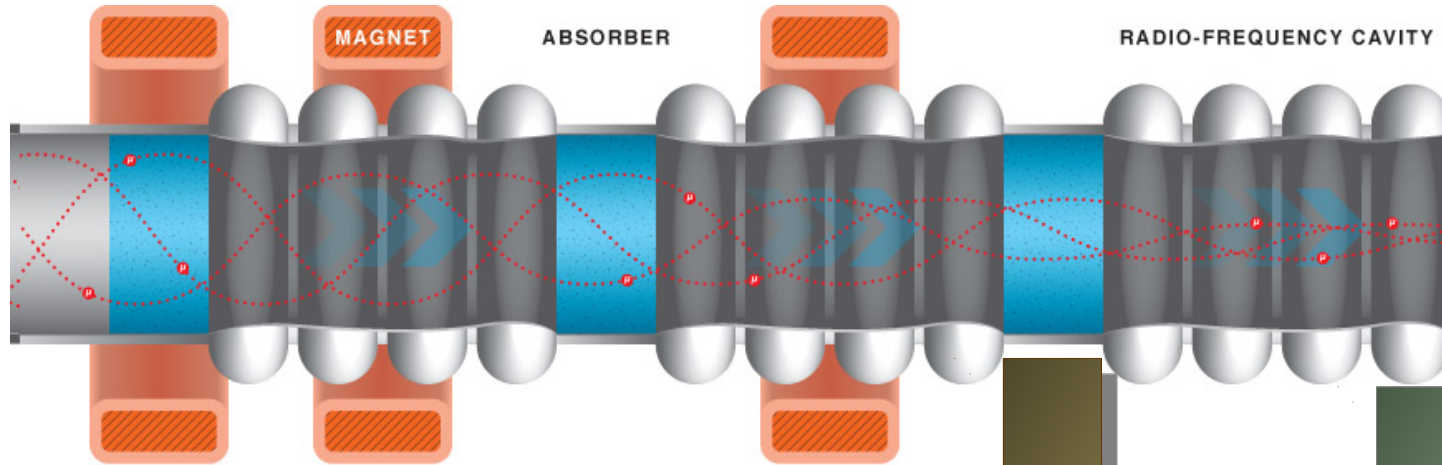

Cooling by ionization energy loss

$$\frac{d\varepsilon_T}{dx} \approx -\frac{\varepsilon_T}{\beta^2 E_\mu} \left\langle \frac{dE}{dx} \right\rangle + \frac{\beta_T (13.6 \text{ MeV}/c)^2}{2\beta^3 E_\mu m_\mu X_0}$$

Minimize heating by multiple (Coulomb) scattering: $\downarrow \beta_T$ (strong focusing), $\uparrow dE/dx \cdot X_0$ (low-Z material)

Minimize $\varepsilon_{\text{equilibrium}}$ (minimum achievable ε from balance of cooling and heating terms)

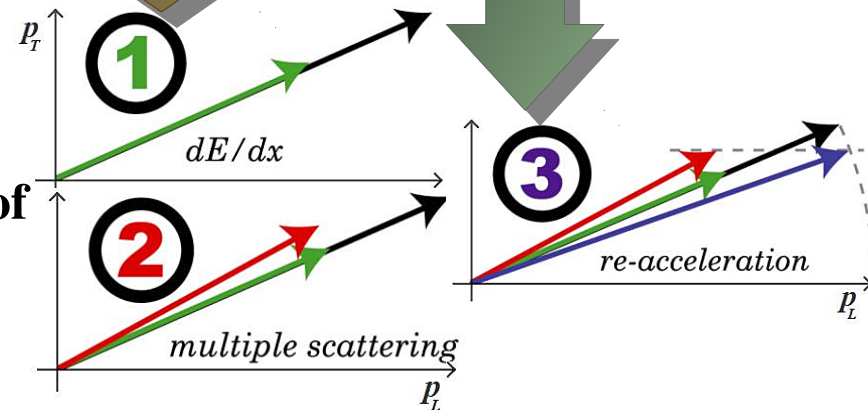

Overview

- ▶ Motivation
- ▶ Muon Ionization Cooling
- ▶ Muon Ionization Cooling Experiment (MICE):
 - Collaboration, experimental site
 - Concept, single-particle nature, status
 - Beamline, detectors, optics
- ▶ Demonstration of Ionization Cooling:
 - Material studies
 - Ionization cooling
- ▶ Conclusion and Future Prospects

Experimental Site and the Collaboration



- Situated at **Rutherford Appleton Laboratory (RAL)** in U.K.
- Over **100** collaborators, **10** countries, **30** institutions

Overview

- ▶ Motivation
- ▶ Muon Ionization Cooling
- ▶ Muon Ionization Cooling Experiment (MICE):
 - Collaboration, experimental site
 - Concept, single-particle nature, status
 - Beamline, detectors, optics
- ▶ Demonstration of Ionization Cooling:
 - Material studies
 - Ionization cooling
- ▶ Conclusion and Future Prospects

Muon Ionization Cooling Experiment (MICE)

Measure muon position and momentum in Spectrometer Solenoid using scintillating fiber tracker, upstream of absorber

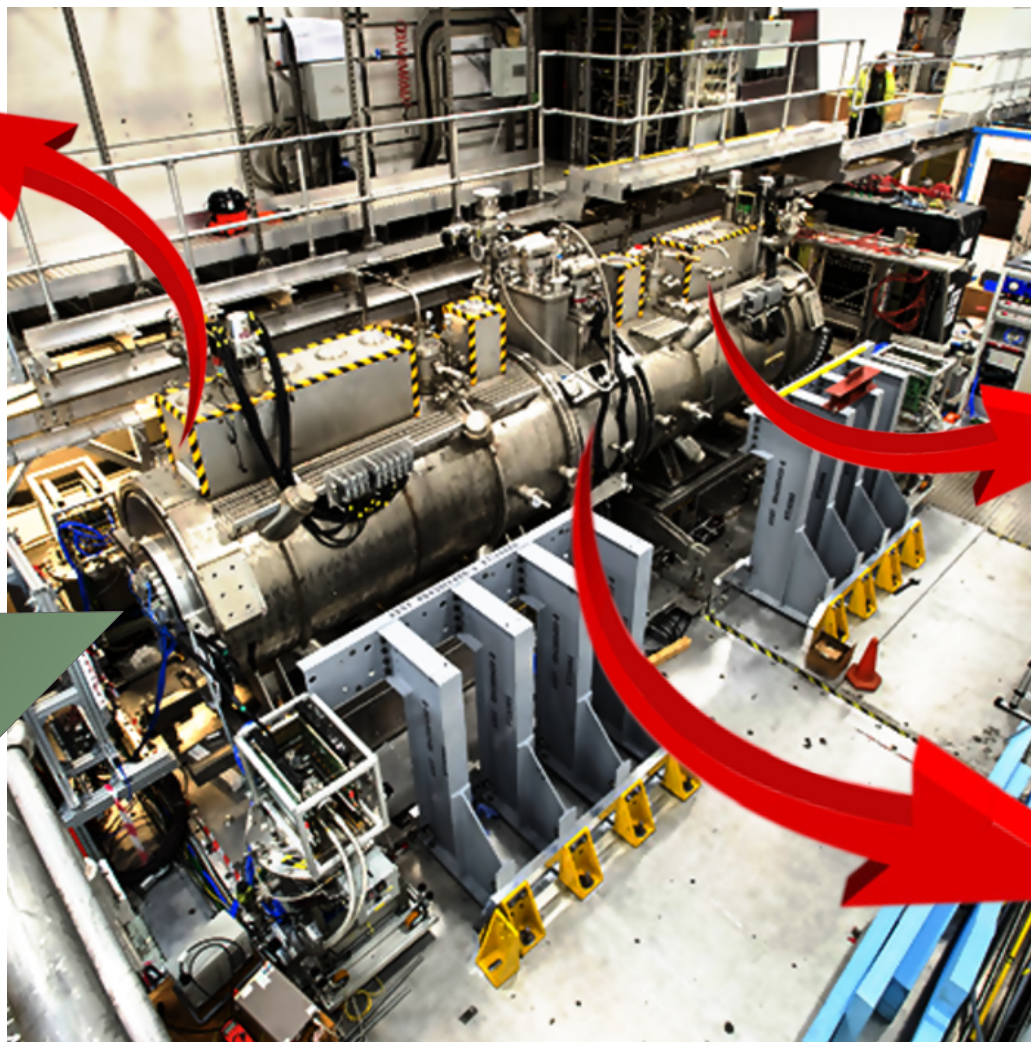

Measure muon position and momentum again downstream and compare with upstream

Cool the muon beam using LiH, LH₂, or polyethylene wedge absorbers

Cooling Measurement with MICE – Concept

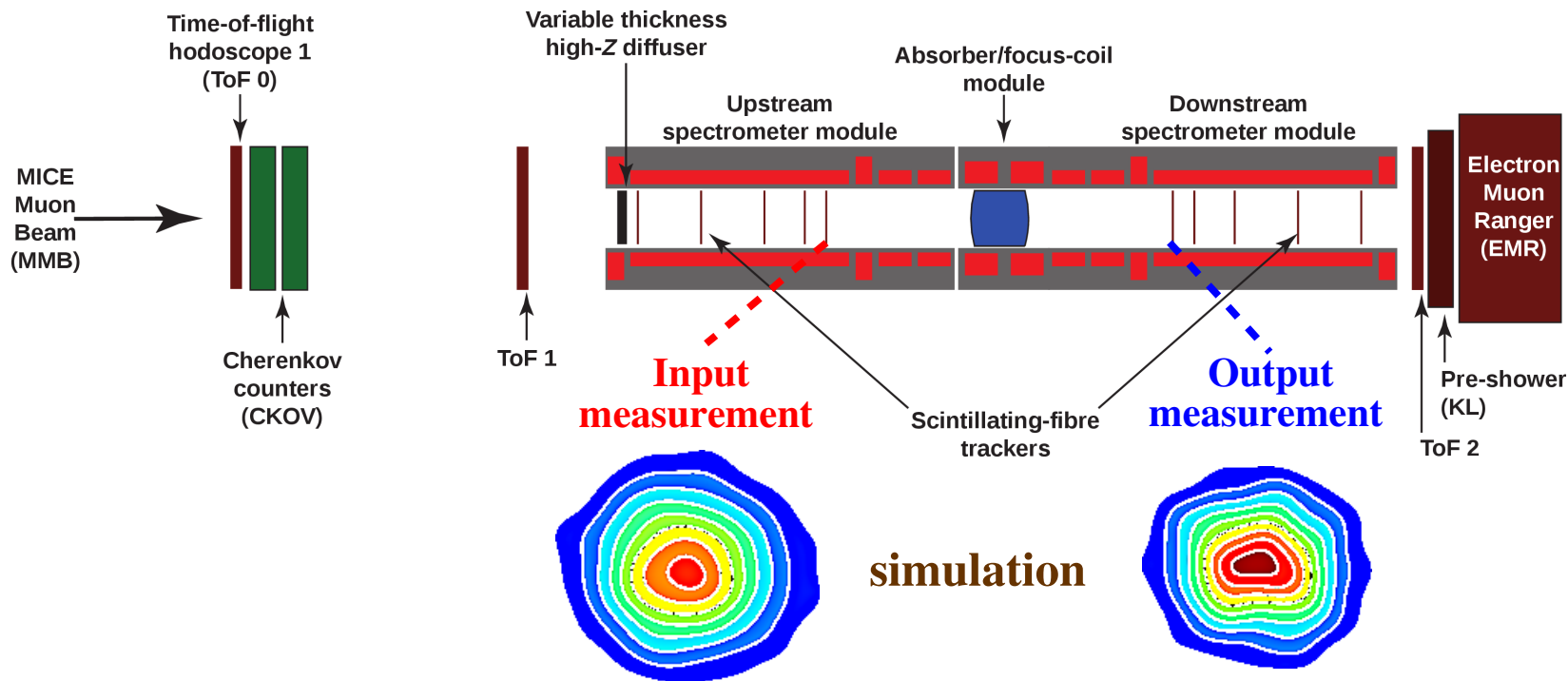

- Test cooling performance in different absorber and optics configurations
- Requires emittance measurement precision of 0.1% → achievable with use of **particle detectors**
- Muons measured **one-by-one**:
 - ★ Changes in **density**, **volume**, **emittance**, **amplitude** before (input) and after (output) the absorber

Single Particle Measurement

- Emittance measurement precision of 0.1% only achievable with use of **particle detectors and single particle measurement approach**
 - ★ Novel beam cooling measurements possible
- Muons entering the experiment **one-by-one**:
 - ★ **Multiple (~100) single muon tracks** recorded in each spill
 - ★ Muon tracks **bunched at the analysis level** (e.g. for emittance calculation)

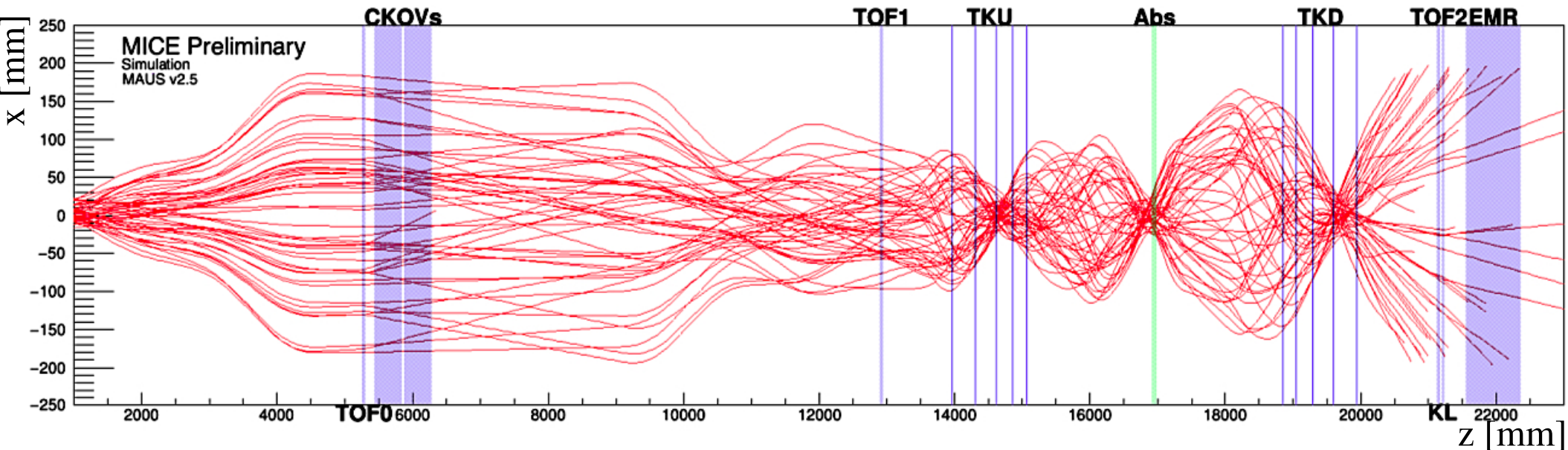

MICE Status I

- Successfully **concluded all data taking** over a range of p_μ , ϵ_n , absorber material (LiH, LH₂, polyethylene), focusing conditions
- Now in the analysis phase:

- ★ **Material properties of LH₂ and LiH:**

- ▶ Contribution THPML058

- ★ **Beam cooling in six dimensions (6D) and four dimensions (4D):**

- ▶ Contributions TUPML062, TUPML063, TUPML065, TUPML067

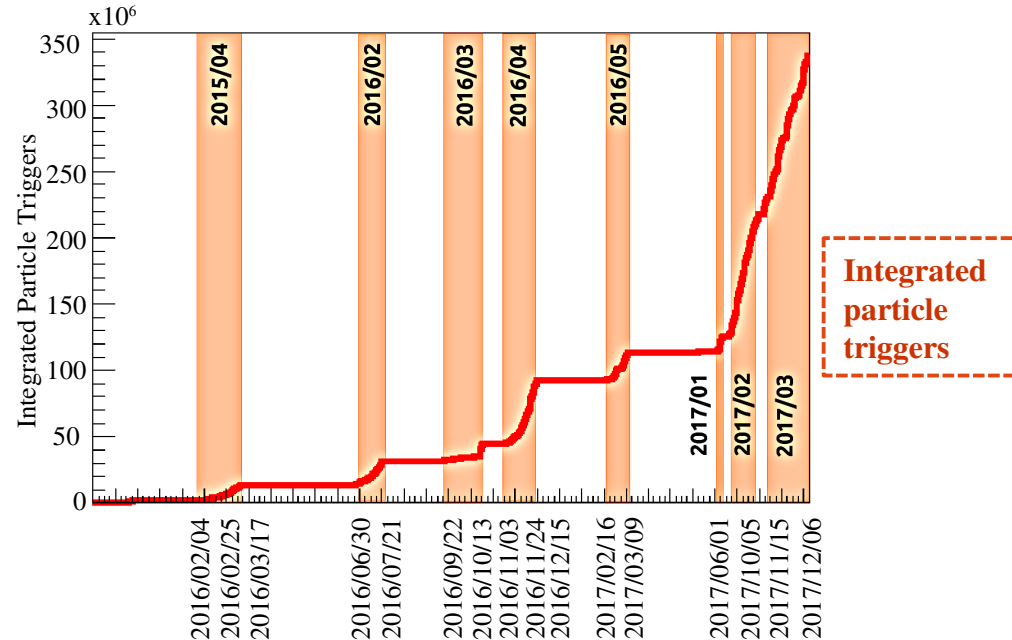
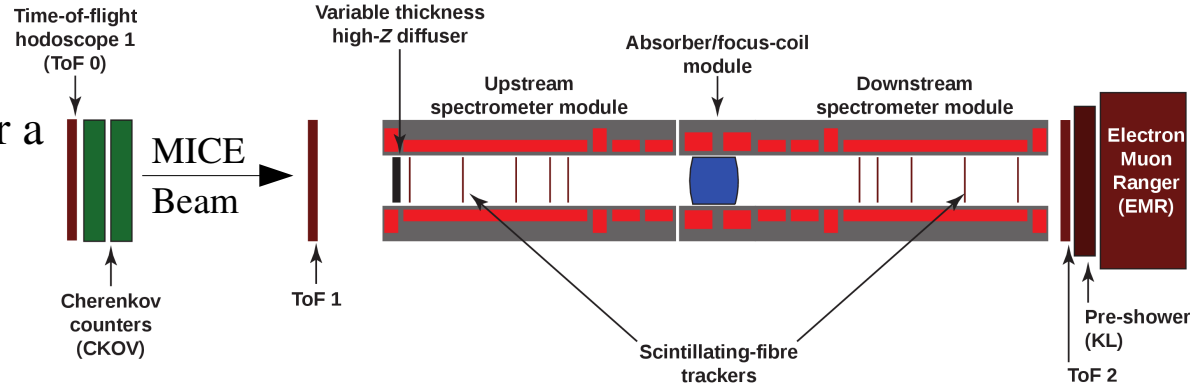

MICE Status II

- Data taken with **polyethylene wedge** absorber for direct **6D cooling** (necessary for future muon collider)
- **Direct 6D ionization cooling** not possible with **flat** absorber due to straggling in ionization energy loss
- Instead use **emittance exchange**: higher energy muons go through more material (longitudinal cooling in exchange for transverse heating)

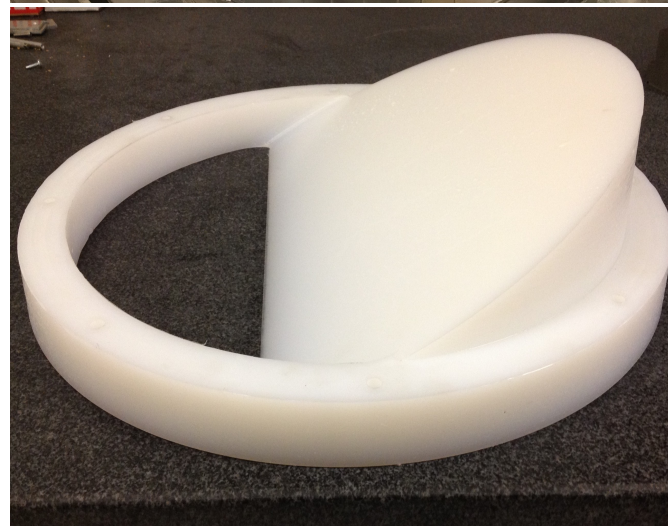
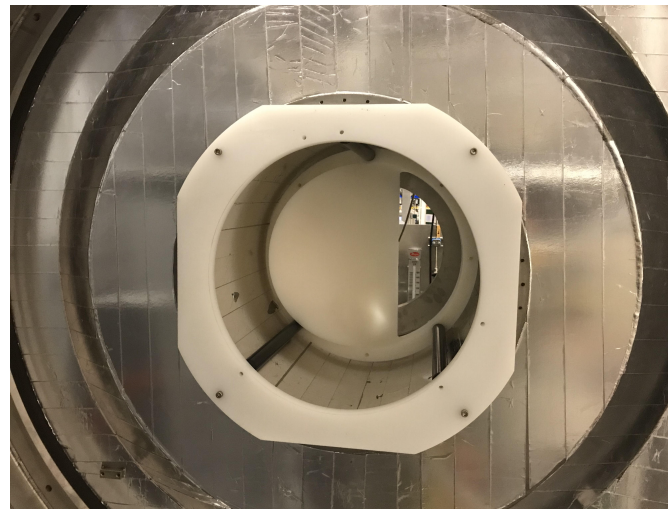
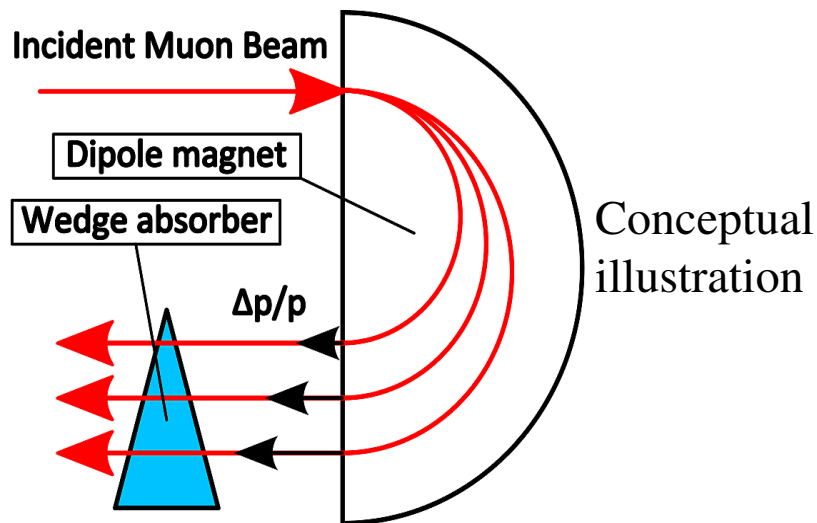

Overview

- ▶ Motivation
- ▶ Muon Ionization Cooling
- ▶ **Muon Ionization Cooling Experiment (MICE):**
 - Collaboration, experimental site
 - Concept, single-particle nature, status
 - **Beamline, detectors, optics**
- ▶ Demonstration of Ionization Cooling:
 - Material studies
 - Ionization cooling
- ▶ Conclusion and Future Prospects

MICE Muon Beam

- ISIS 800 MeV proton beam bombarding MICE pulsed titanium target
- p_μ : [140, 300] MeV/c, ϵ_T : [2π , 10π] mm rad

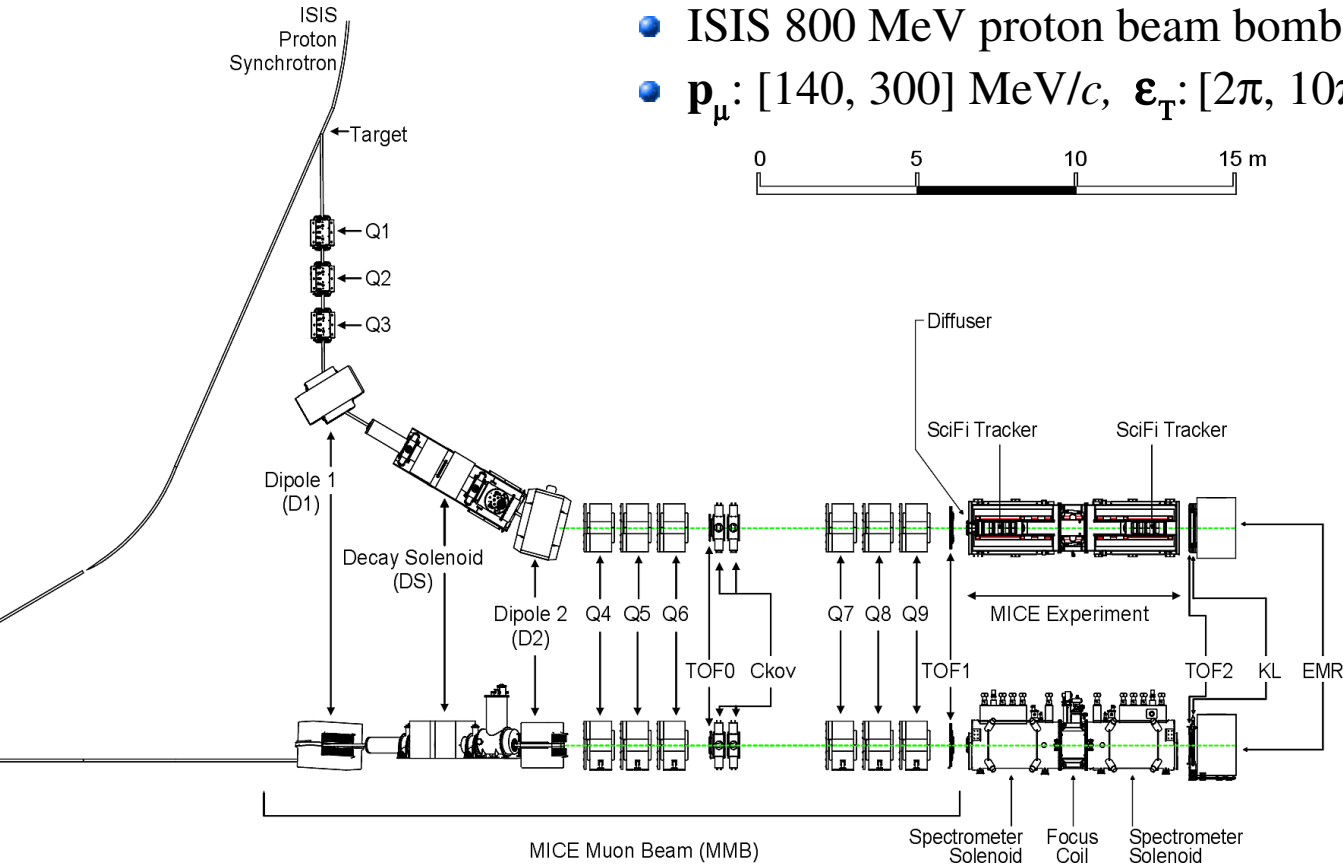

“Muonic” setting “Pionic” setting

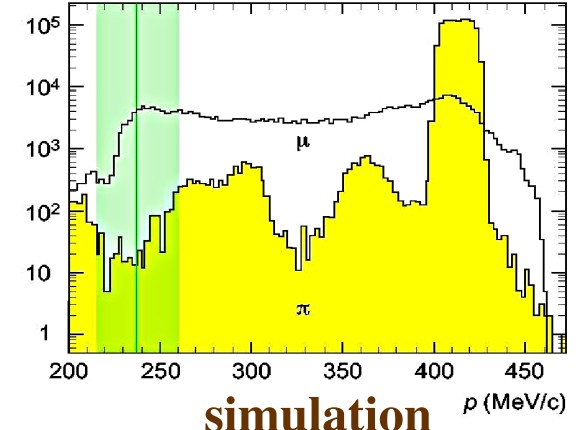

simulation

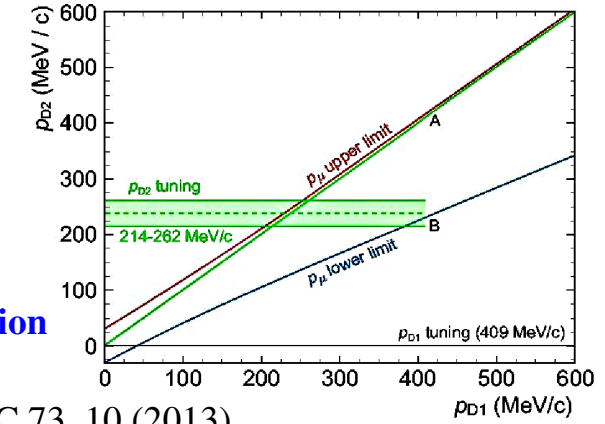

• The MICE Muon Beam on ISIS and the beam-line instrumentation of the Muon Ionization Cooling Experiment, JINST 7, P05009 (2012)

• Characterisation of the muon beams for the Muon Ionisation Cooling Experiment, EPJ C 73, 10 (2013)

MICE Detectors

- Beam purity detectors – **time of flight**, **Cherenkov**

counters, **calorimetry** – μ beam has small e , π contents:

- ★ π content with KL and TOF < 1.4%
- ★ e tag efficiency with EMR > 98.6%

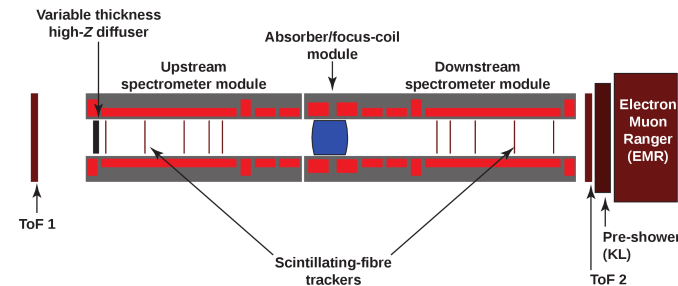
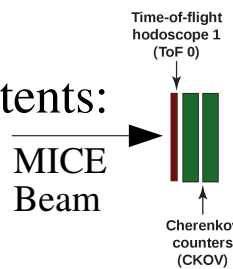

Time of Flight (TOF)

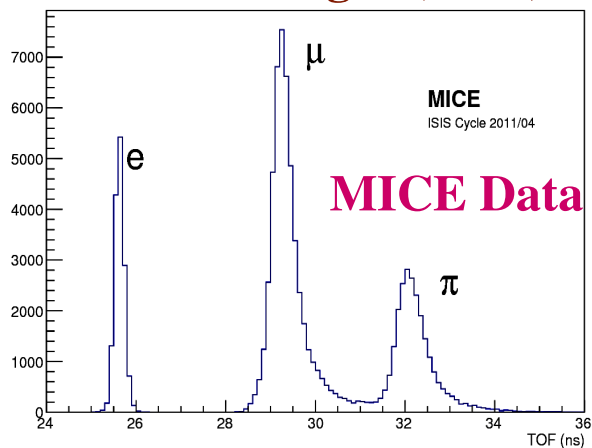

KLOE-Light (KL)

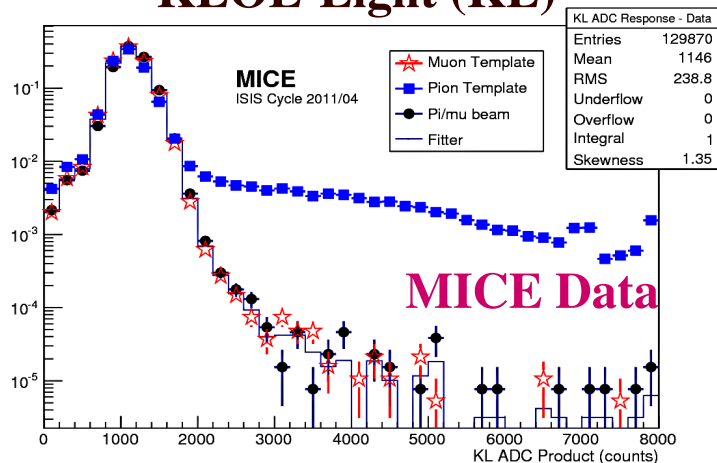

Electron-Muon Ranger (EMR)

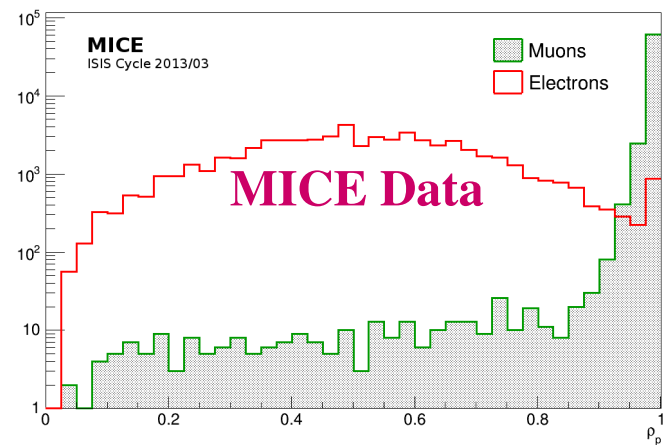

- ★ Pion Contamination in the MICE Muon Beam, JINST 11 P03001 (2016)

- ★ Electron-Muon Ranger (EMR) Performance in the MICE Muon Beam, JINST 10 P12012 (2015)

MICE Tracker Reconstruction

- **Helical tracks** formed in spectrometer solenoids:
- ★ **Phase-space coordinates** of each muon reconstructed in **trackers**

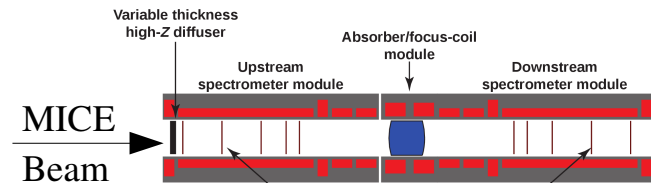
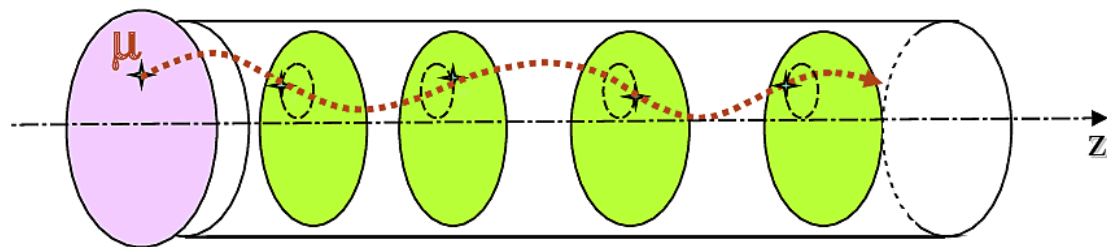

MICE Data

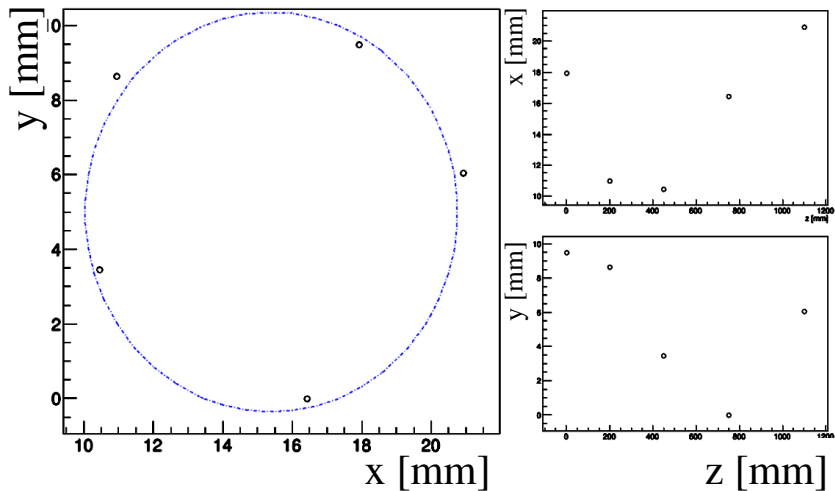
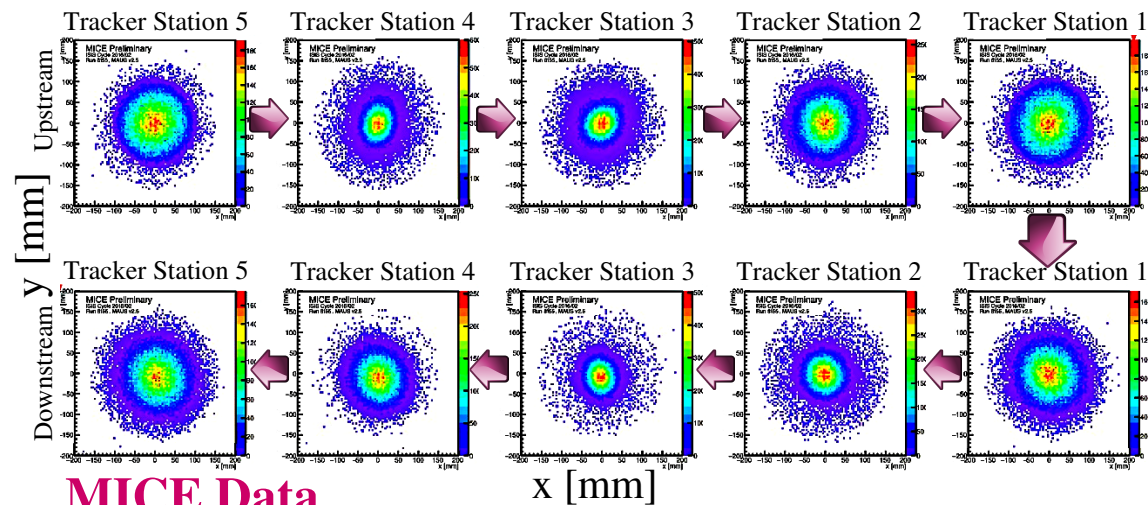

MICE Spectrometer Solenoids (SS)

- 5 superconducting coils in each **SS**, 2 for beam matching, 3 for uniform fields in the tracking volumes
- A pair of coils in the **Absorber Focus Coil (AFC)** module, which holds the absorber.
- Operating in solenoid (same polarity) and flip (opposite polarity) modes, max operating field of 3T

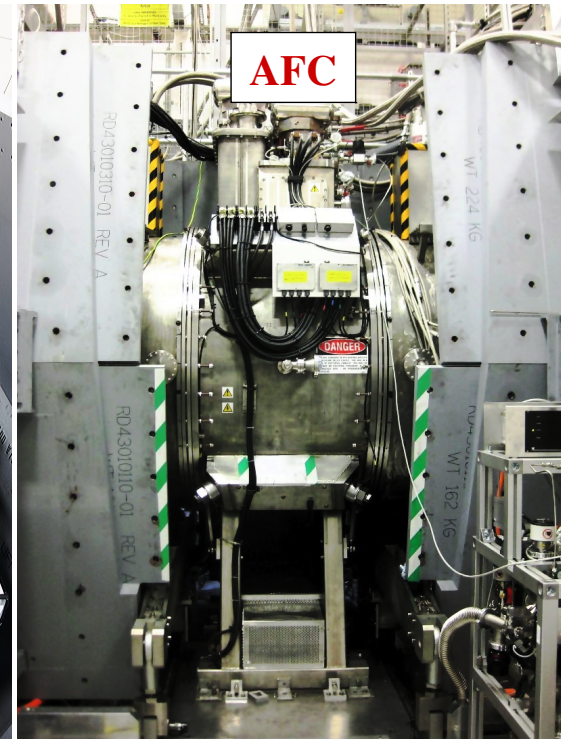
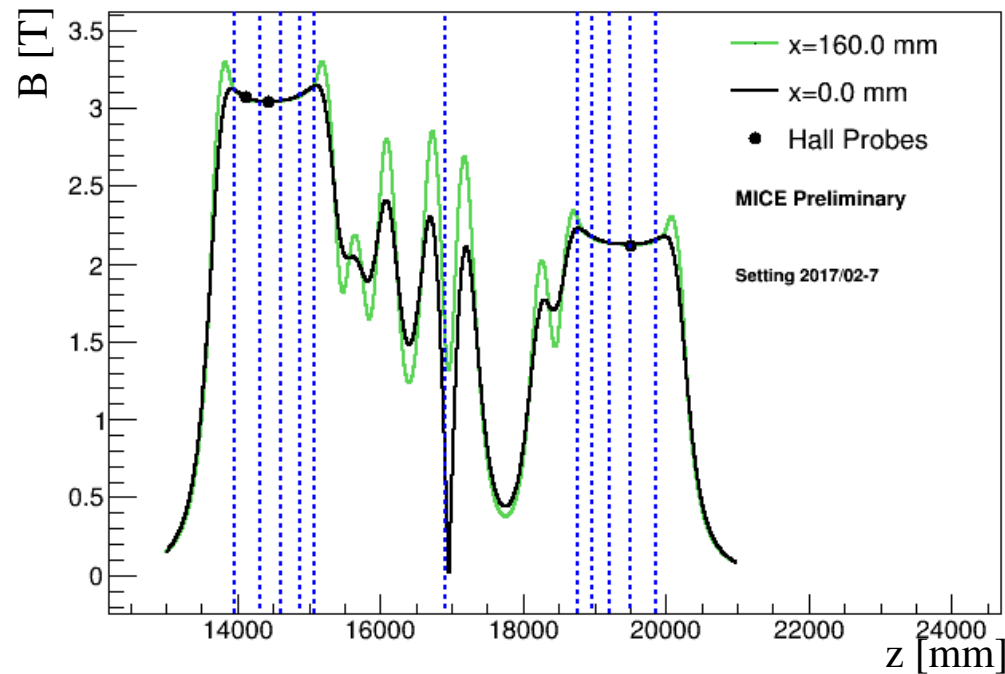

Overview

- ▶ Motivation
- ▶ Muon Ionization Cooling
- ▶ Muon Ionization Cooling Experiment (MICE):
 - Collaboration, experimental site
 - Concept, single-particle nature, status
 - Beamline, detectors, optics
- ▶ **Demonstration of Ionization Cooling:**
 - **Material studies**
 - Ionization cooling
- ▶ Conclusion and Future Prospects

Multiple Coulomb Scattering

YZ Projected Scattering Angle

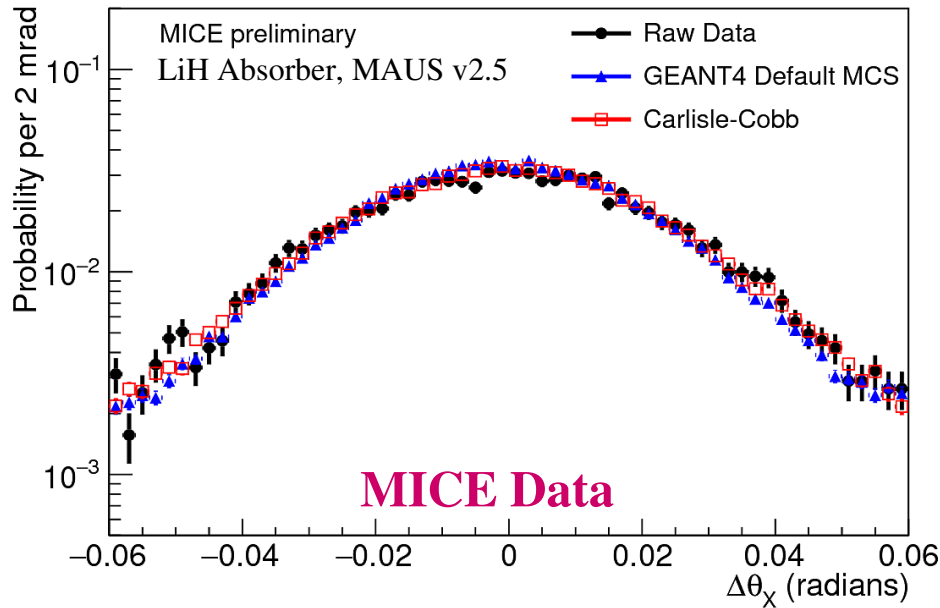

XZ Projected Scattering Angle

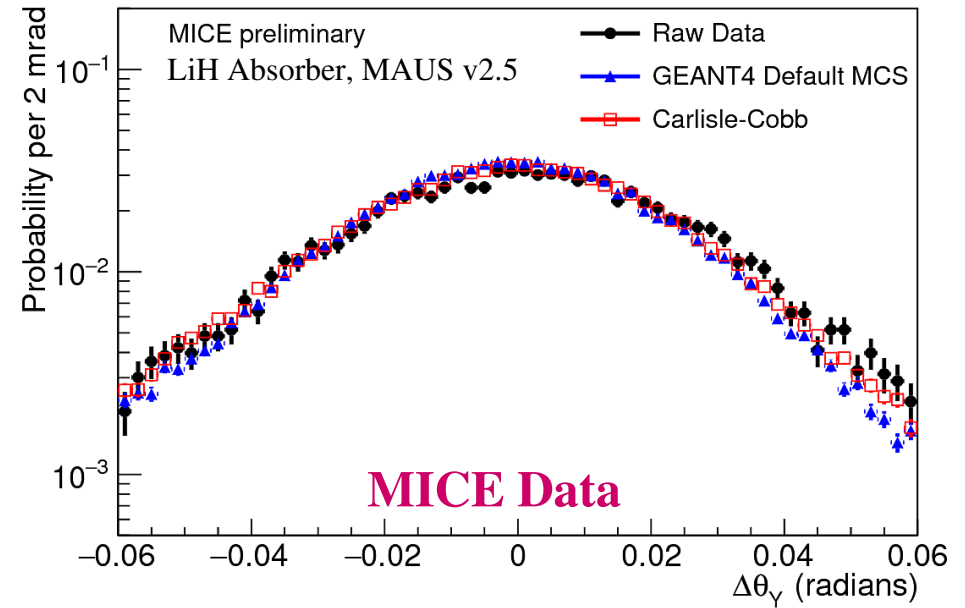

- Multiple scattering causes beam **heating**, needs to be well-understood in MICE
- Characterized as the **angle** between the initial and final momentum as projected onto **YZ and XZ**

Overview

- ▶ Motivation
- ▶ Muon Ionization Cooling
- ▶ Muon Ionization Cooling Experiment (MICE):
 - Collaboration, experimental site
 - Concept, single-particle nature, status
 - Beamline, detectors, optics
- ▶ Demonstration of Ionization Cooling:
 - Material studies
 - Input emittance study, Ionization cooling
- ▶ Conclusion and Future Prospects

Emittance Measurement

- Reconstruct position and momentum coordinates using **MICE trackers**

- Construct **covariance matrix**,

$$\Sigma = \begin{pmatrix} \sigma_{xx} & \sigma_{p_x x} & \sigma_{yx} & \sigma_{p_y x} \\ \sigma_{xp_x} & \sigma_{p_x p_x} & \sigma_{yp_x} & \sigma_{p_y p_x} \\ \sigma_{xy} & \sigma_{p_x y} & \sigma_{yy} & \sigma_{p_y y} \\ \sigma_{xp_y} & \sigma_{p_x p_y} & \sigma_{yp_y} & \sigma_{p_y p_y} \end{pmatrix}$$

$$\sigma_{xp_x} = \langle xp_x \rangle - \langle x \rangle \langle p_x \rangle$$

- Compute transverse normalized RMS emittance,

$$\varepsilon_T = \frac{|\Sigma|^{1/4}}{m_\mu}$$

$$\sigma_{xx}^2$$

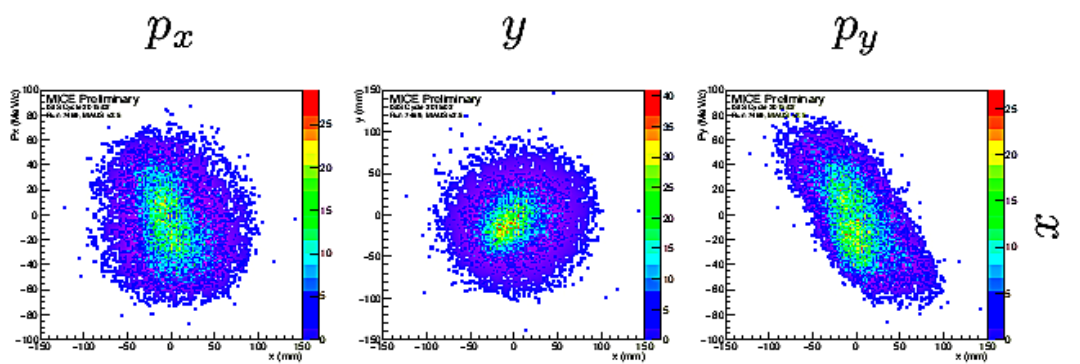

$$\sigma_{p_x p_x}^2$$

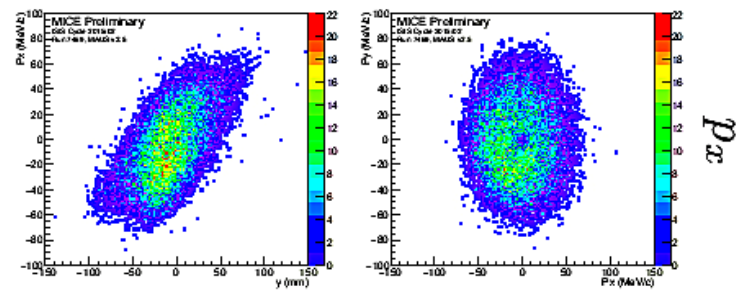

$$\sigma_{yy}^2$$

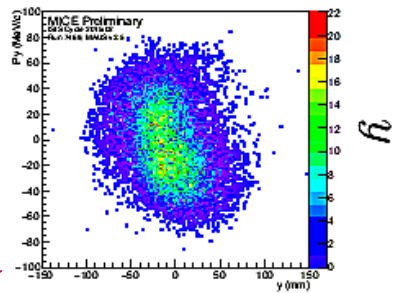

MICE Data

Input Emittance Measurement, Beam Selection

- **Beam selection** to reject π and e
- μ **time of flight** and **momentum** selected

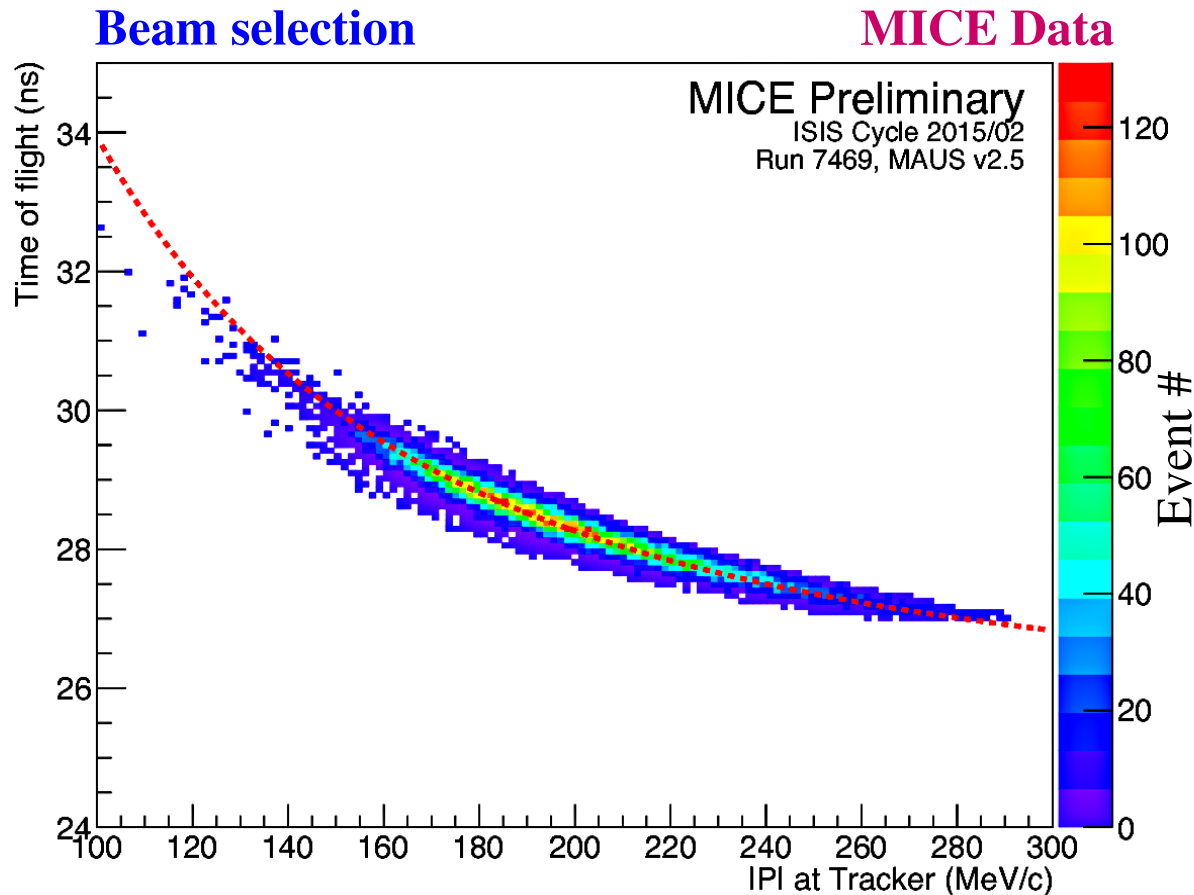
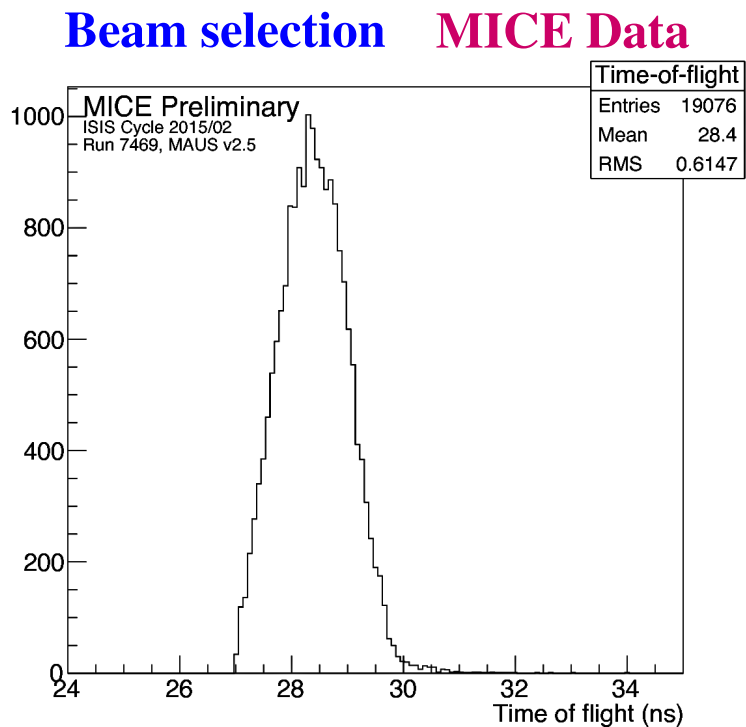

Input Emittance Result

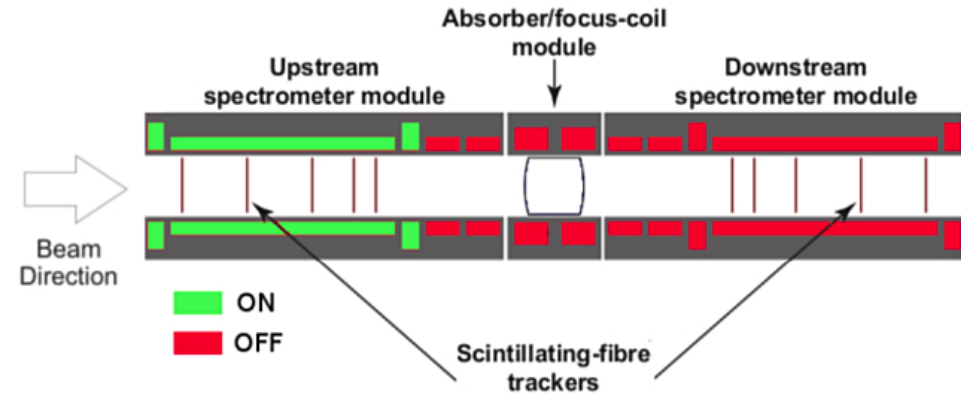

- Goal: measure the input beam emittance using the **upstream tracker**
- **First direct** measurement of **emittance** using **scintillating fiber tracking detectors**

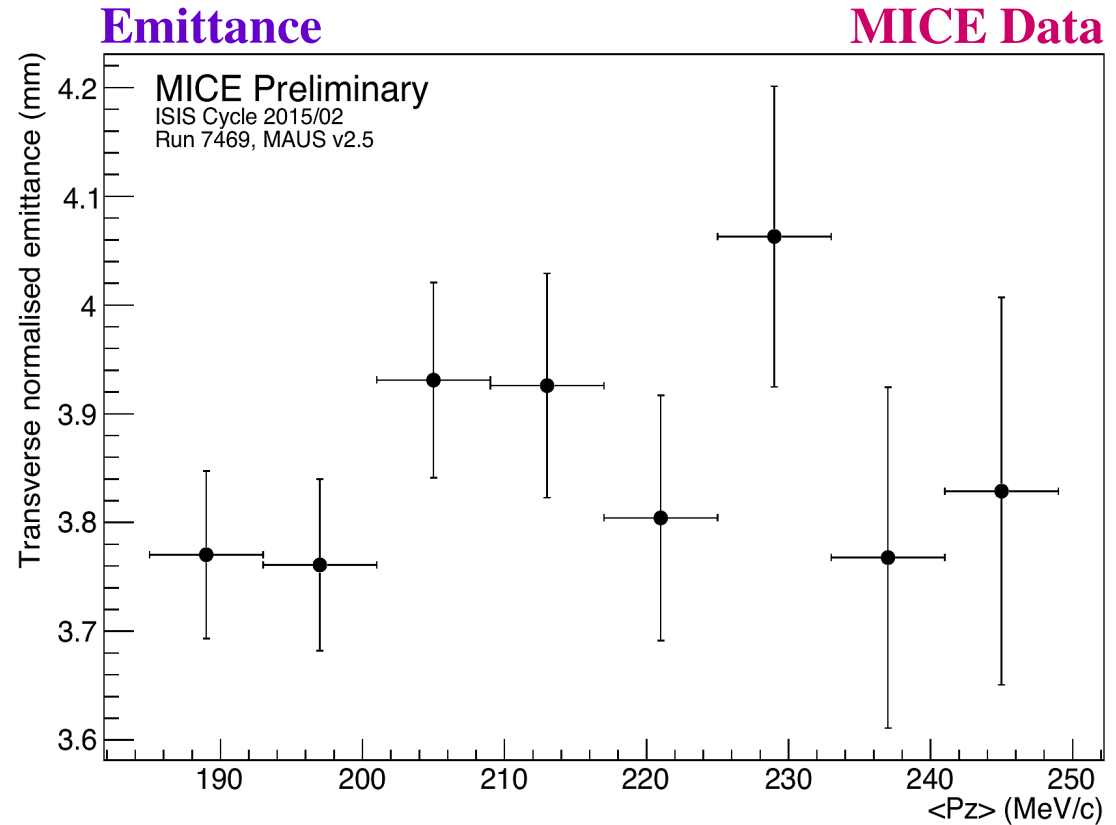

Single-particle Amplitude I

Amplitude, 1D and 2D Example

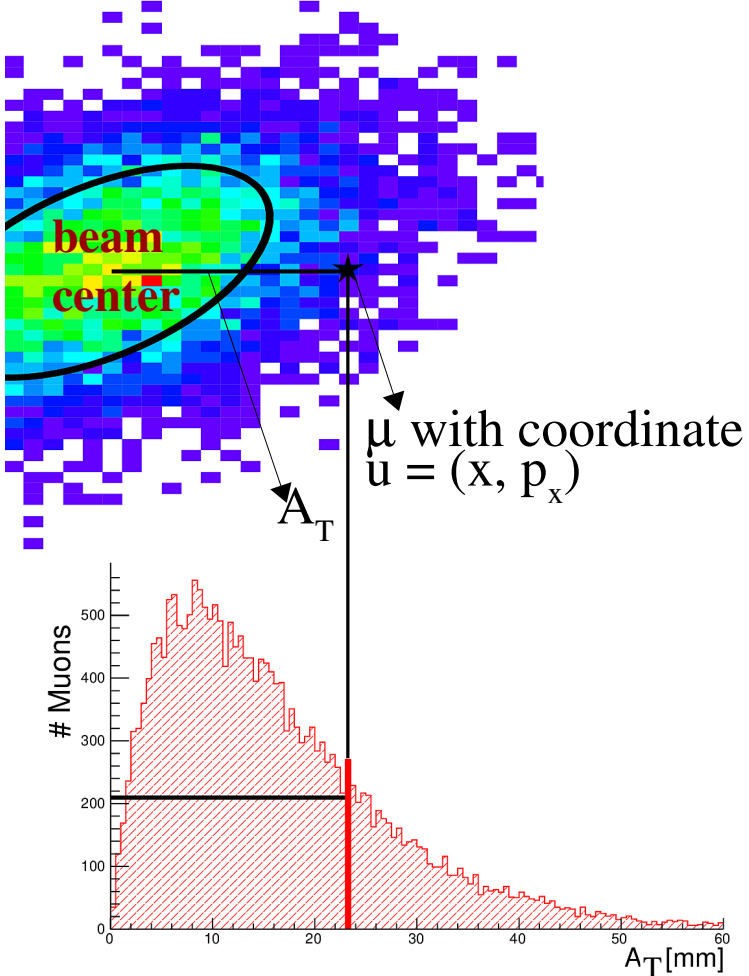

- Defined as the distance of a muon from the beam center
- Reconstruct position and momentum coordinates using the **trackers**
- Construct **covariance matrix**
- Compute transverse normalized RMS emittance

$$\varepsilon_T = \frac{|\Sigma|^{1/4}}{m_\mu}$$

- Compute transverse amplitude,

$$A_T = \varepsilon_T u^T \Sigma^{-1} u$$

Single-particle Amplitude II

1D example: beam cooling with amplitude

$\times 10^2$

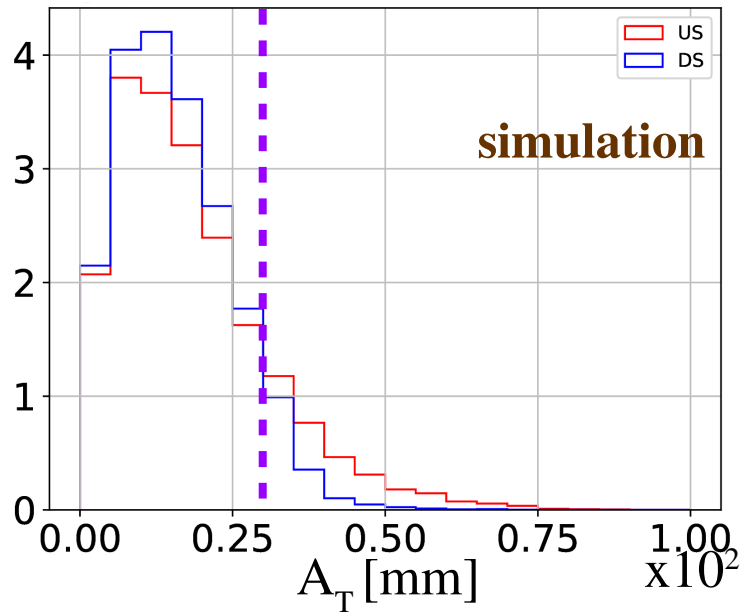

- Terminology:
 - ★ Beam core: left of the **dashed vertical line** towards the low amplitude, beam tail: right of the **dashed vertical line** towards the high amplitude, boundary at distribution 1σ
- Expected cooling trend:
 - ★ Dominated by the average migration of muons from high amplitude tail to low amplitude core
 - ★ Take ratio of **upstream** to **downstream** histogram, if $> 1 \Rightarrow$ cooling
 - ★ Take ratio of **upstream** to **downstream** cumulative distribution function (integrated over muon count with amplitude equal to or less than the amplitude under study), if $> 1 \Rightarrow$ cooling

Momentum Distributions

Upstream of LH₂ Absorber

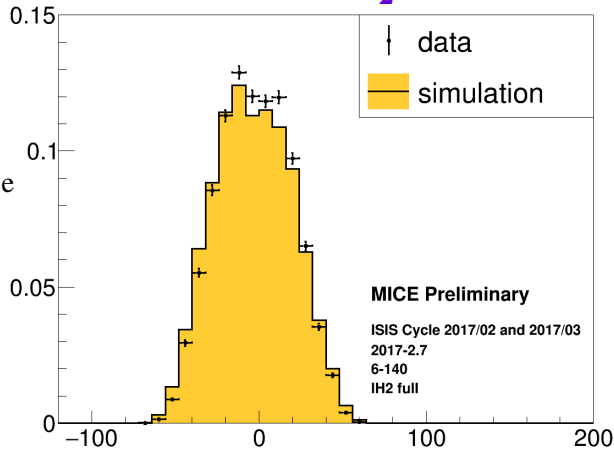

Downstream of LH₂ Absorber

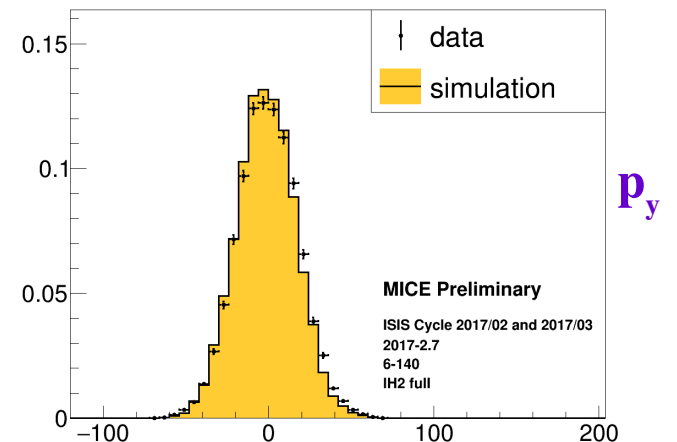
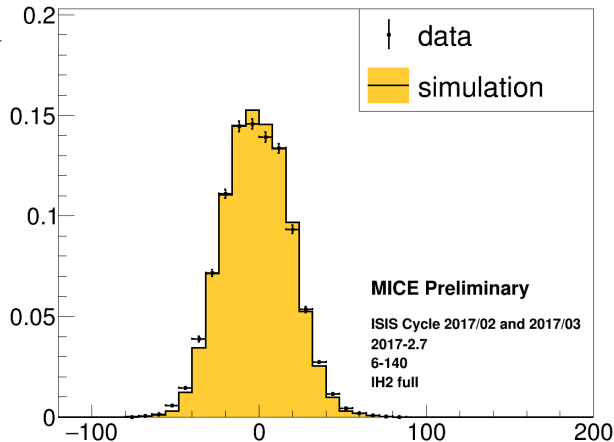
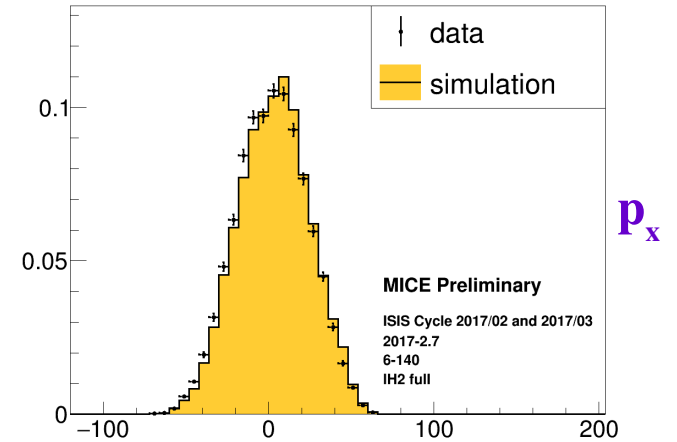

- 140 MeV/c = $P_{\text{reference}}$
- 6 mm = ϵ_{input}
- LH₂ absorber
- 660 mm = β_T
- **Excellent agreement** between data and simulation

Single-particle Amplitude Result

MICE Data

No absorber

LH2

LiH

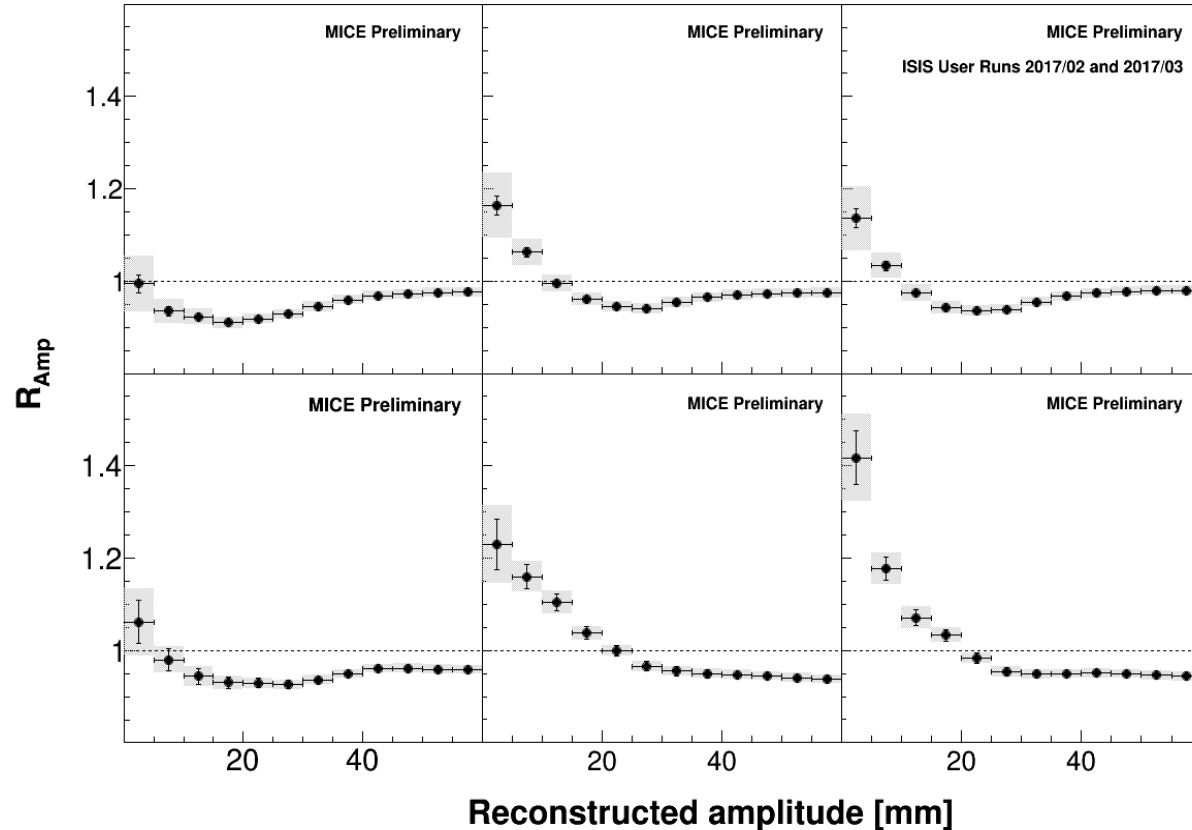

● **6-140** – $P_{\text{reference}}$ of 140 MeV/c
and ϵ_{input} of 6 mm

● **10-140** – $P_{\text{reference}}$ of 140 MeV/c
and ϵ_{input} of 10 mm

6-140

● R_{Amp} : ratio of downstream muon
count to upstream

● **$R_{\text{Amp}} > 1 \rightarrow$ cooling:**

★ Migration of high amplitude
muons to low amplitude

10-140

● “No absorber” does not show
cooling, agrees with Liouville's
theorem

Overview

- ▶ Motivation
- ▶ Muon Ionization Cooling
- ▶ Muon Ionization Cooling Experiment (MICE):
 - Collaboration, experimental site
 - Concept, single-particle nature, status
 - Beamline, detectors, optics
- ▶ Demonstration of Ionization Cooling:
 - Material studies
 - Input emittance study, Ionization cooling
- ▶ Conclusion and Future Prospects

Conclusion and Future Prospects

- **MICE has measured muon ionization cooling!**
- Scattering data taken and analysis nearly complete
- LiH and LH₂ data taken and analysis underway
- Preliminary measurements of emittance and amplitude complete
- Wedge data taken and analysis underway
- Many papers published and more papers in preparation:
<http://mice.iit.edu/publications/>

Thank you for listening!

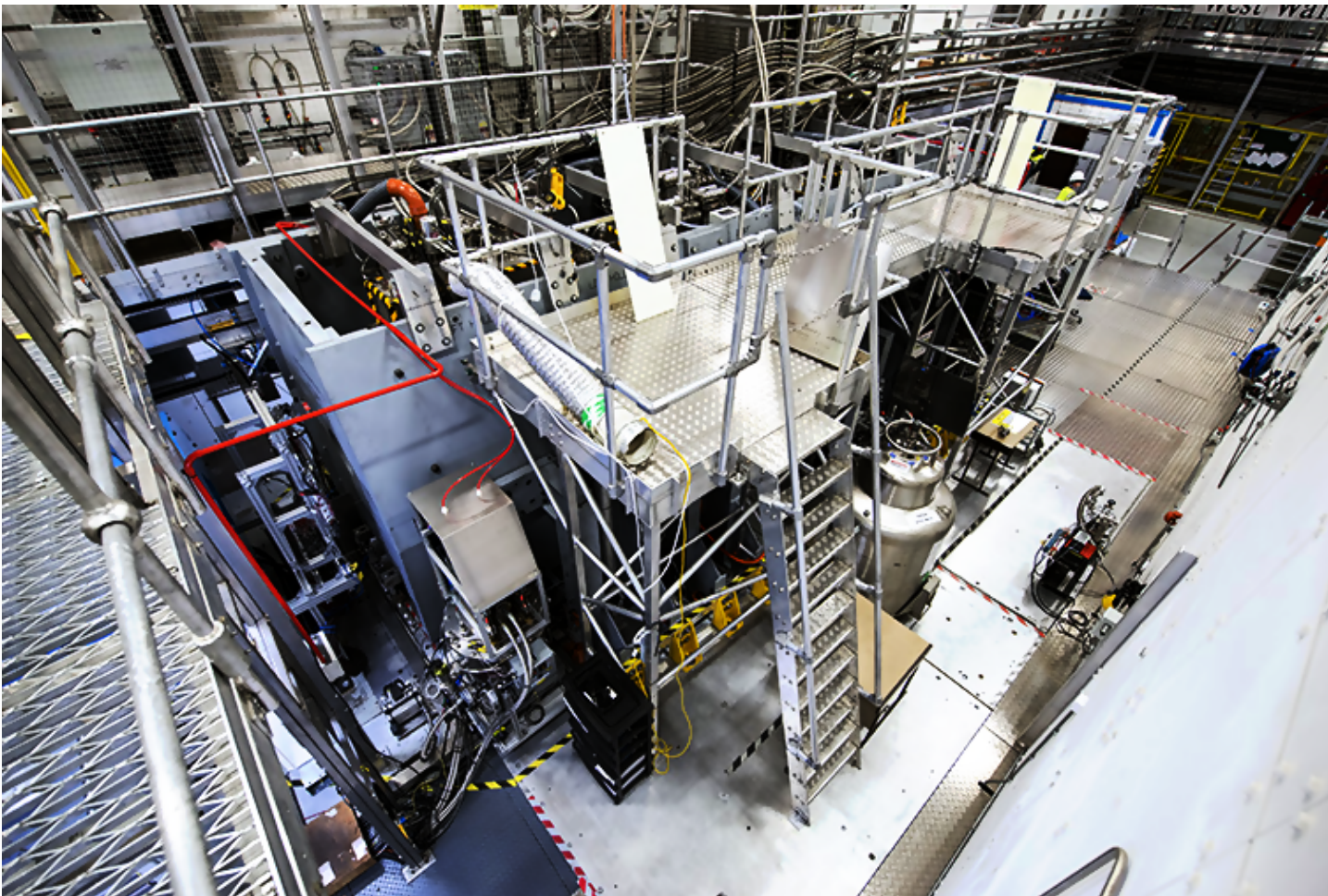

MICE has been made possible by grants from DOE, NSF (USA), the INFN (Italy), the STFC (UK), the European Community, the Japan Society for the Promotion of Science, and the Swiss National Science Foundation. We are grateful to the support given to us by the staff of the STFC Rutherford Appleton and Daresbury Laboratories. We acknowledge the use of Grid computing resources deployed and operated by GridPP in the UK, <http://www.gridpp.ac.uk/>.

Travel to IPAC'18 supported by the United States National Science Foundation, the Division of Physics of Beams of the American Physical Society, and TRIUMF

Additional Slides

MICE Muon Beam – Detail

- 800 MeV proton beam from ISIS proton synchrotron:
 - ★ 4 μC of protons in two 100 ns long pulses
 - ★ Beam current: 200 μA
- MICE titanium target directly dipped into the ISIS proton beam:
 - ★ Dip rate: 1 dip/1.28s
 - ★ Max particle rate:
 - ★ 120 $\mu\text{+}/\text{dip}$
 - ★ 20 $\mu\text{-}/\text{dip}$
- Final μ beam: 1ms wide spill in two 100 ns long bursts every 324 ns.

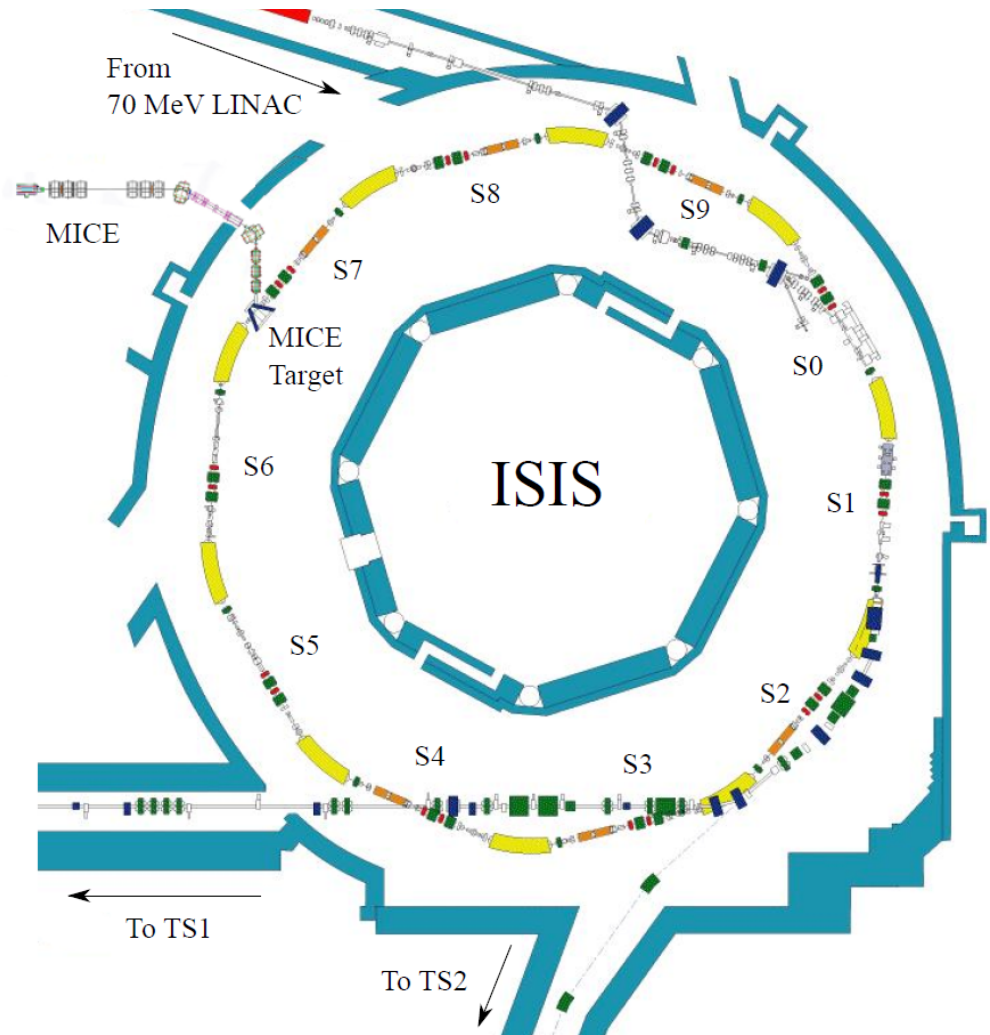

Tracker Reconstruction – Detail

- Scintillating fiber stations:
 - ★ 5 stations per tracker
 - ★ 3 planes per station (mutual orientation @ 120°)
 - ★ 214 fibers per plane
- Measured tracker resolution: $\sigma_x = \sigma_y = 467 \mu\text{m}$
- Immersed in solenoidal fields:
 - ★ Helical tracks formed in solenoids
 - ★ Circle fit in transverse direction \rightarrow radius, ρ and P_T
 - ★ Arc length gradient $\rightarrow p_L$
 - ★ Momentum resolution: σ_{p_L} and $\sigma_{p_T} \sim 1.3$ and $4 \text{ MeV}/c$

$$x = -\rho \cos(q_\mu B t / m_\mu)$$

$$y = \rho \sin(q_\mu B t / m_\mu)$$

$$z = p_L t / m_\mu$$

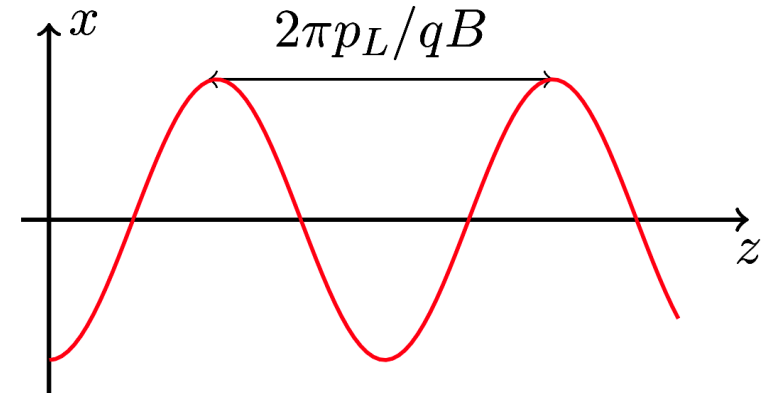
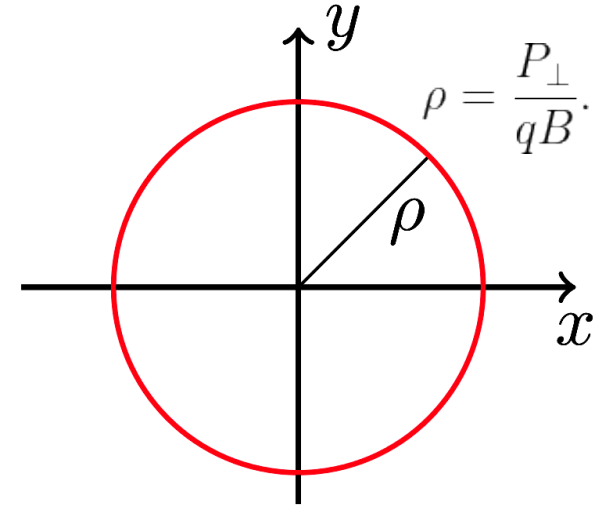

Equilibrium Emittance – Detail

$$\frac{d\varepsilon_T}{dx} \approx \left[-\frac{\varepsilon_T}{\beta^2 E_\mu} \left\langle \frac{dE}{dx} \right\rangle \right] + \left[\frac{\beta_T (13.6 \text{ MeV}/c)^2}{2\beta^3 E_\mu m_\mu X_0} \right]$$

- Set **cooling rate** equal to **heating rate** to get **equilibrium emittance**:

$$\varepsilon \sim \frac{\beta_\perp (13.6 \text{ MeV}/c)^2}{2\beta m_\mu X_0 \left\langle \frac{dE}{dx} \right\rangle}$$

- Smaller equilibrium emittance (better cooling) obtained with minimized β_\perp & maximized $X_0 dE/dx$

ε_T : transverse beam emittance

βc : velocity

E_μ : muon energy

dE/dx : ionization energy loss

β_T : transverse beta function

m_μ : muon mass

X_0 : radiation length