



| The European Synchrotron



ESRF-Double Crystal Monochromator Prototype – Control Concept

Maxim Brendike

Co authors: Gilles Berruyer, Hervé Gonzalez, Ludovic Ducotté,
Cyril Guilloud, Manuel Perez, Robert Baker

1. Introduction DCM

1. What does a Double Crystal Monochromator?
2. The ESRF-DCM prototype

2. The Control Concept

1. Concept of 3 modes
2. Implementation

3. Test setup and results

4. Conclusion

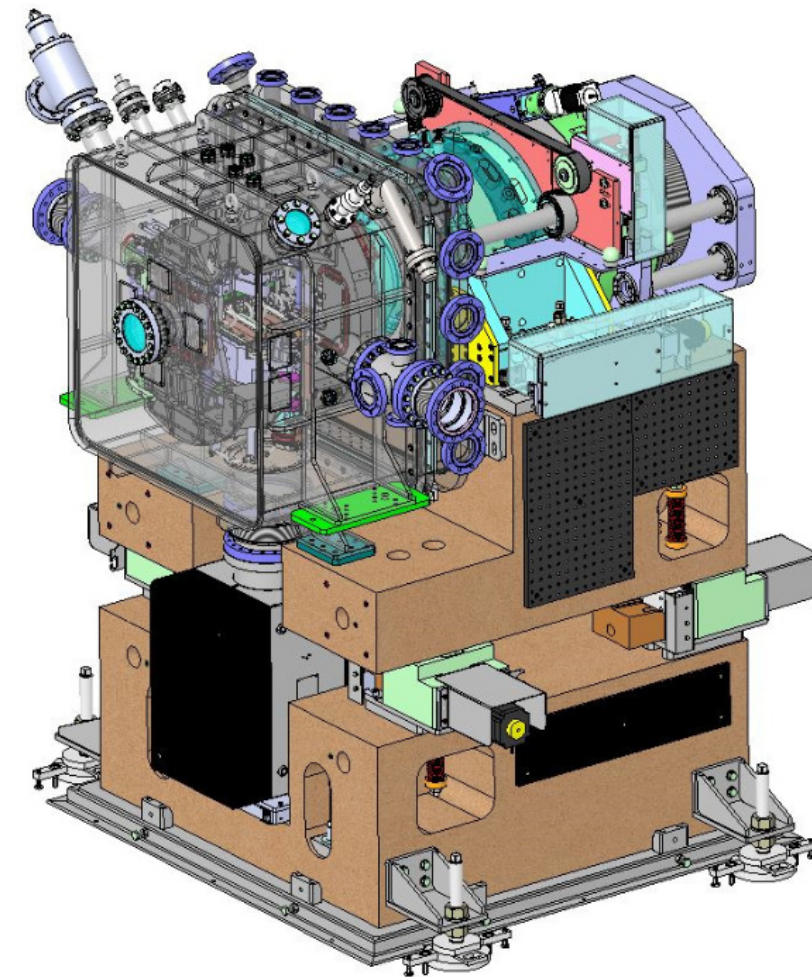

What does a Double Crystal Monochromator?



What does a Double Crystal Monochromator?

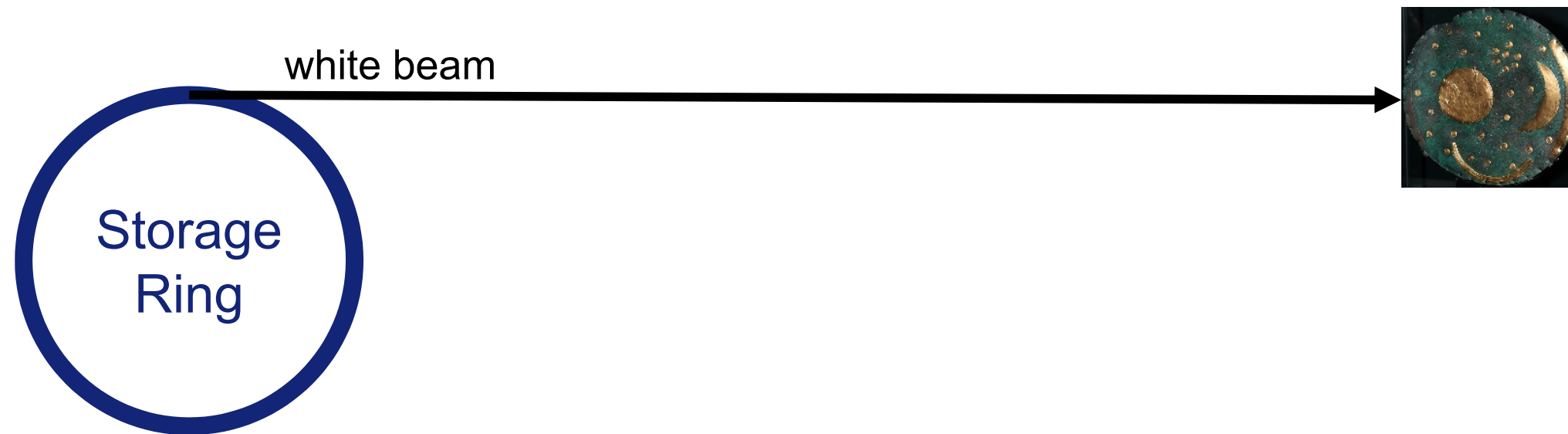

What does a Double Crystal Monochromator?

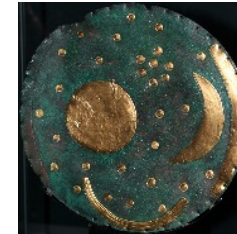
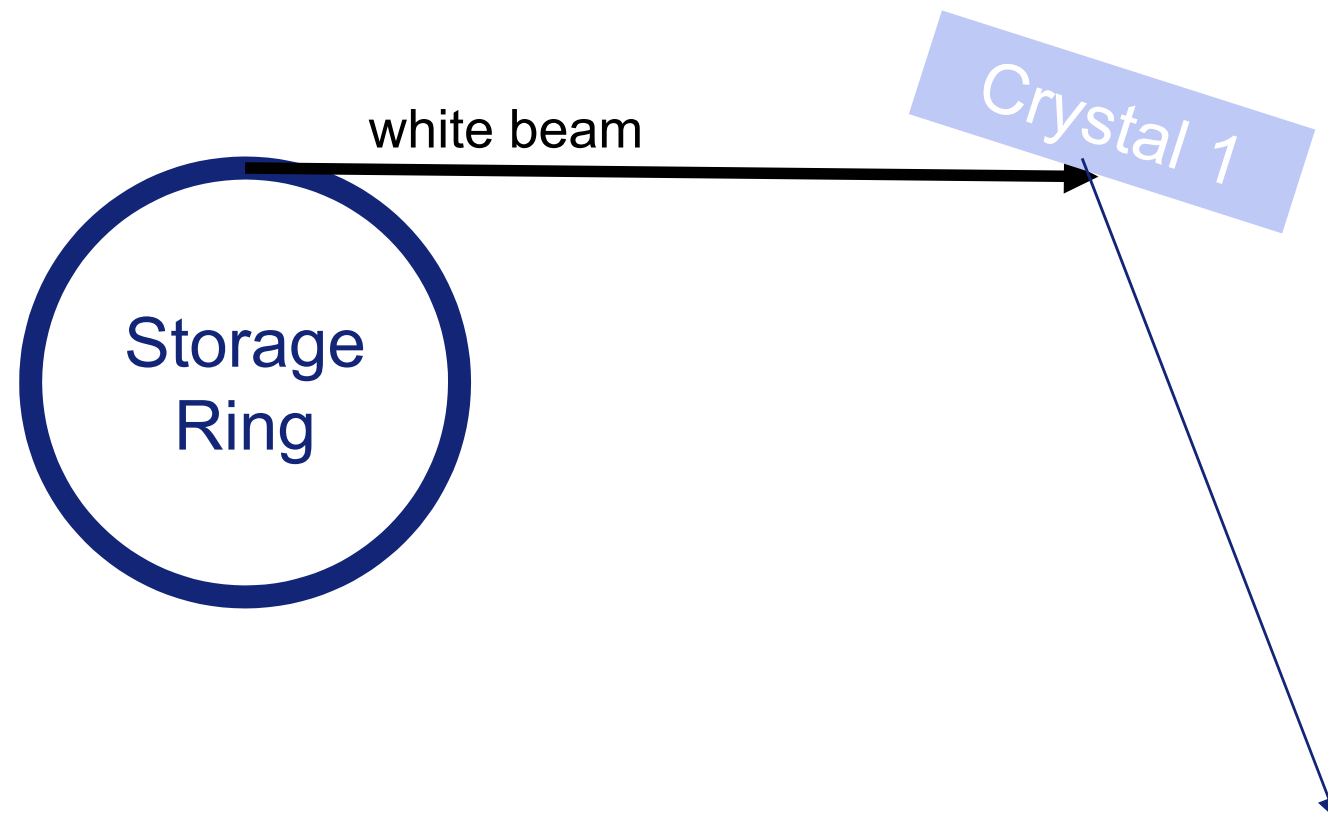

What does a Double Crystal Monochromator?

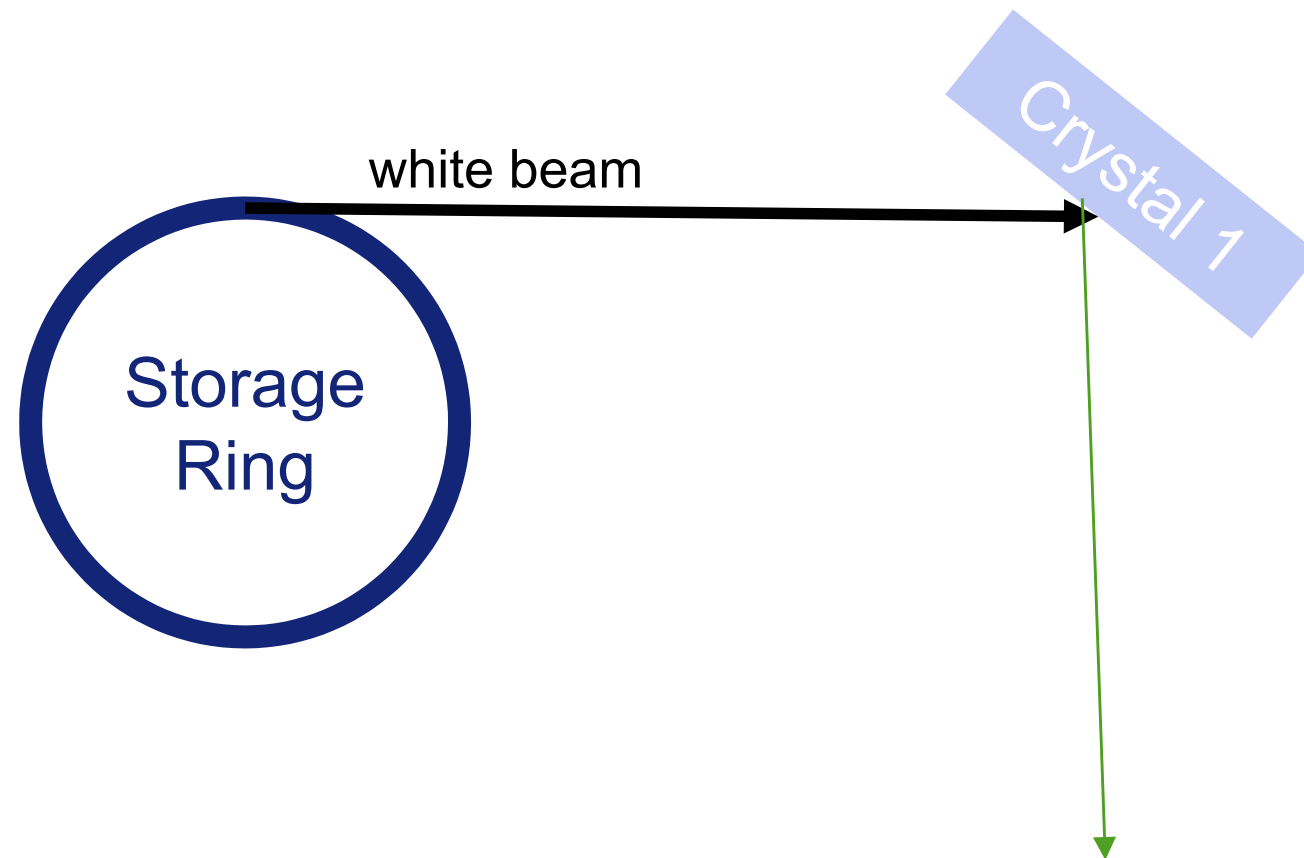

What does a Double Crystal Monochromator?

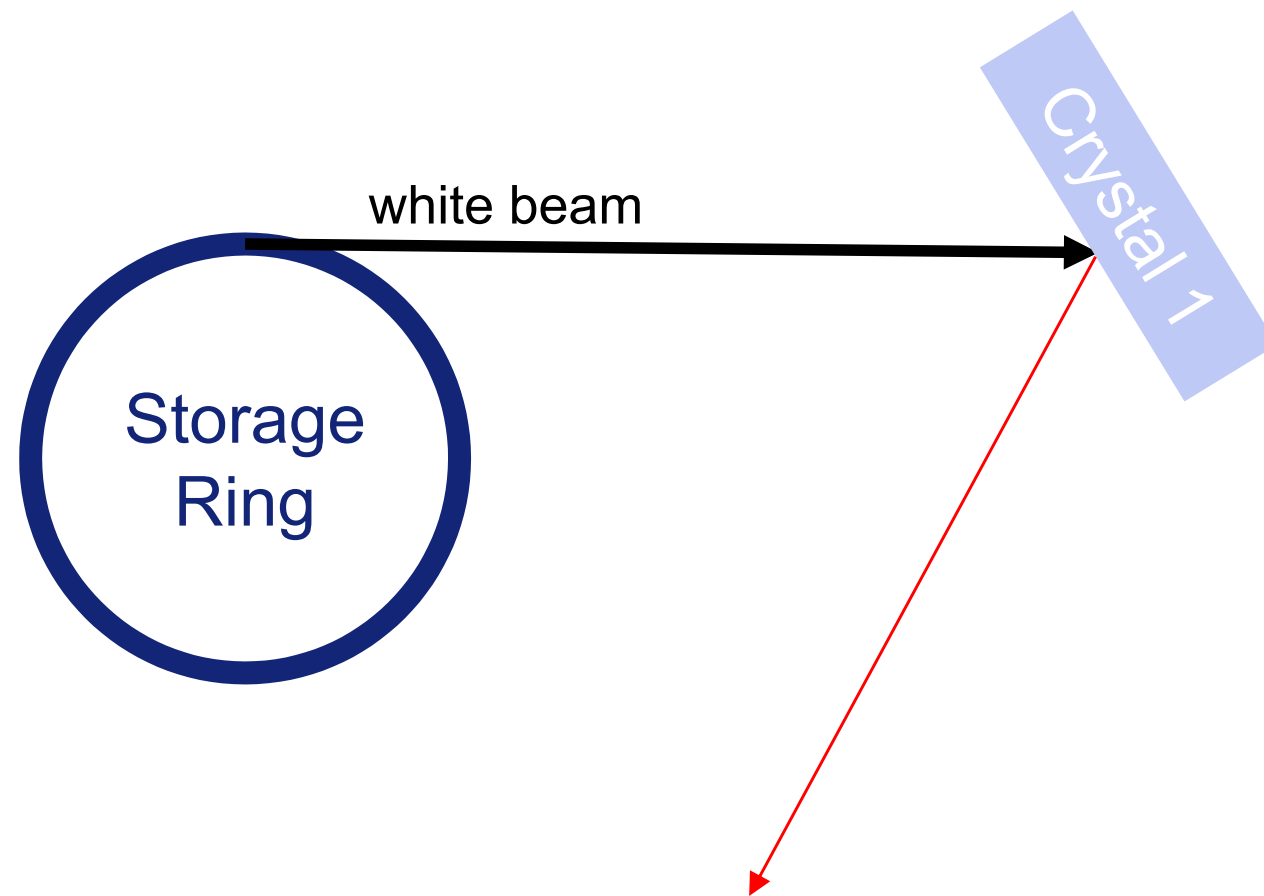

What does a Double Crystal Monochromator?

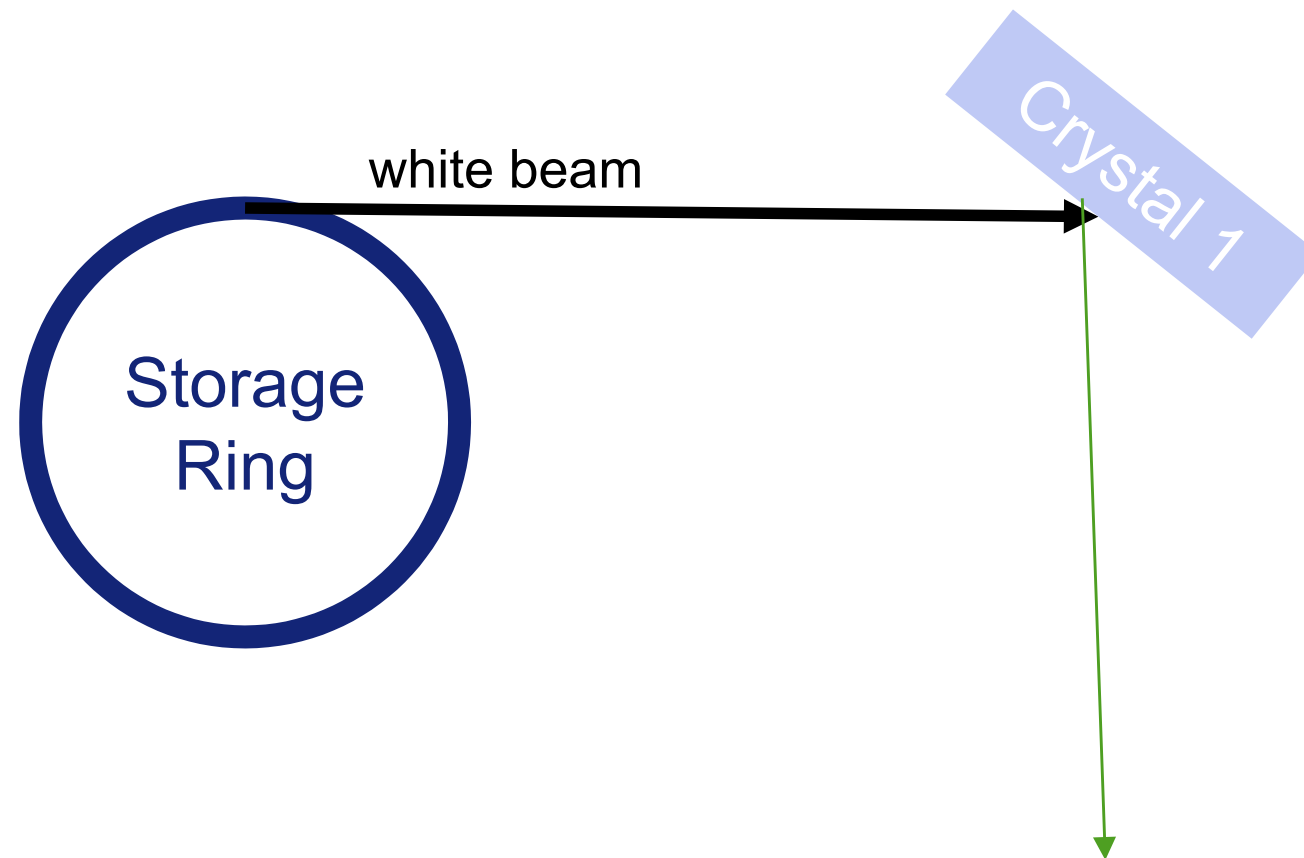

What does a Double Crystal Monochromator?

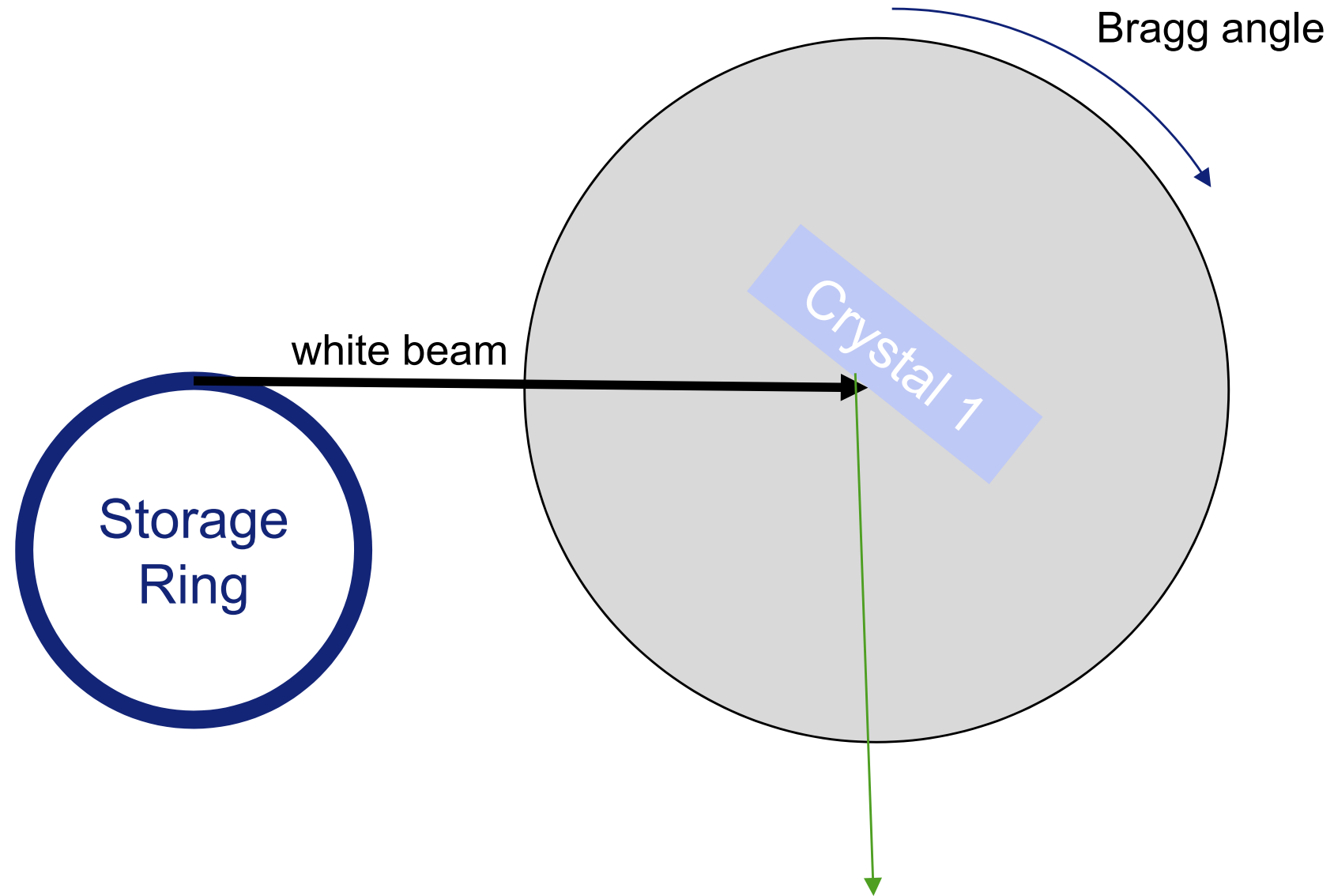

What does a Double Crystal Monochromator?

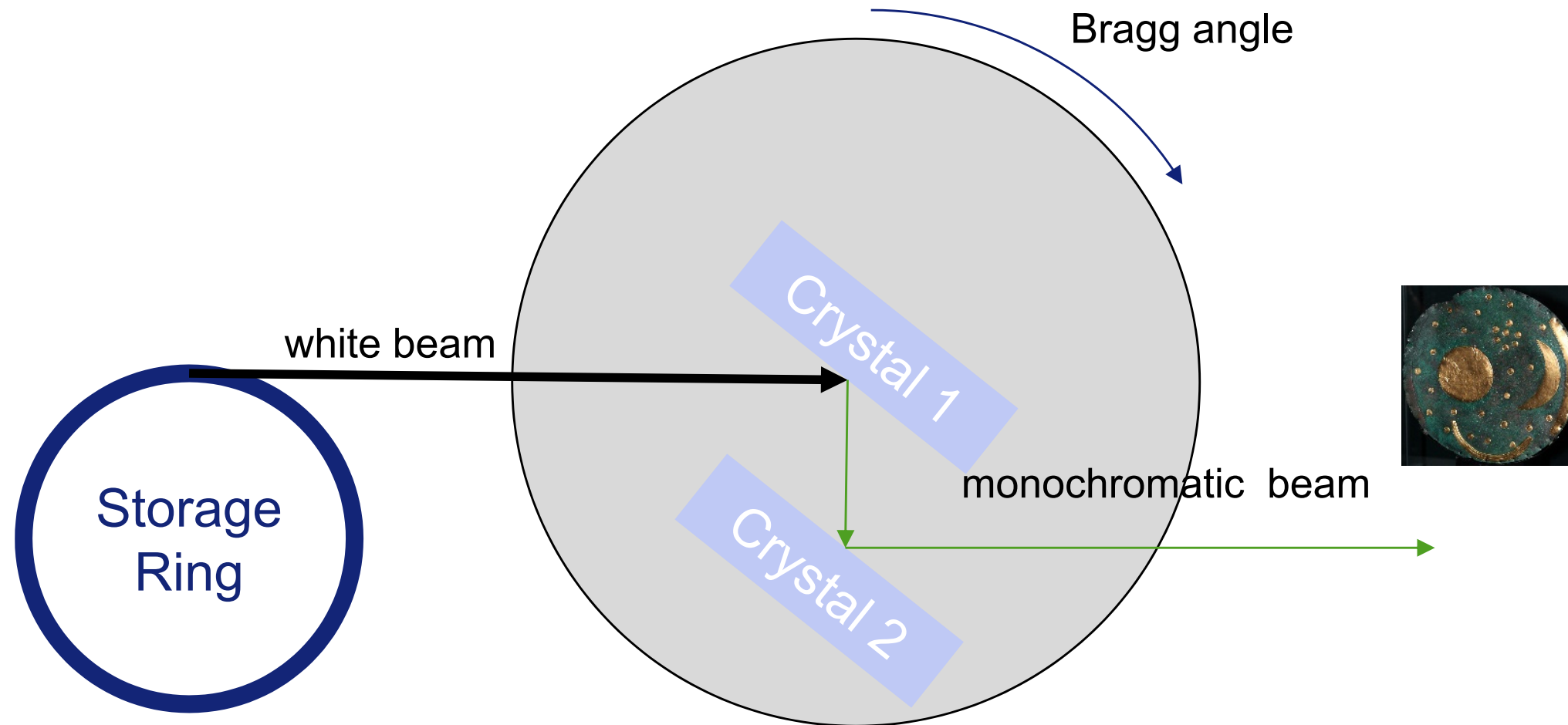

What does a Double Crystal Monochromator?

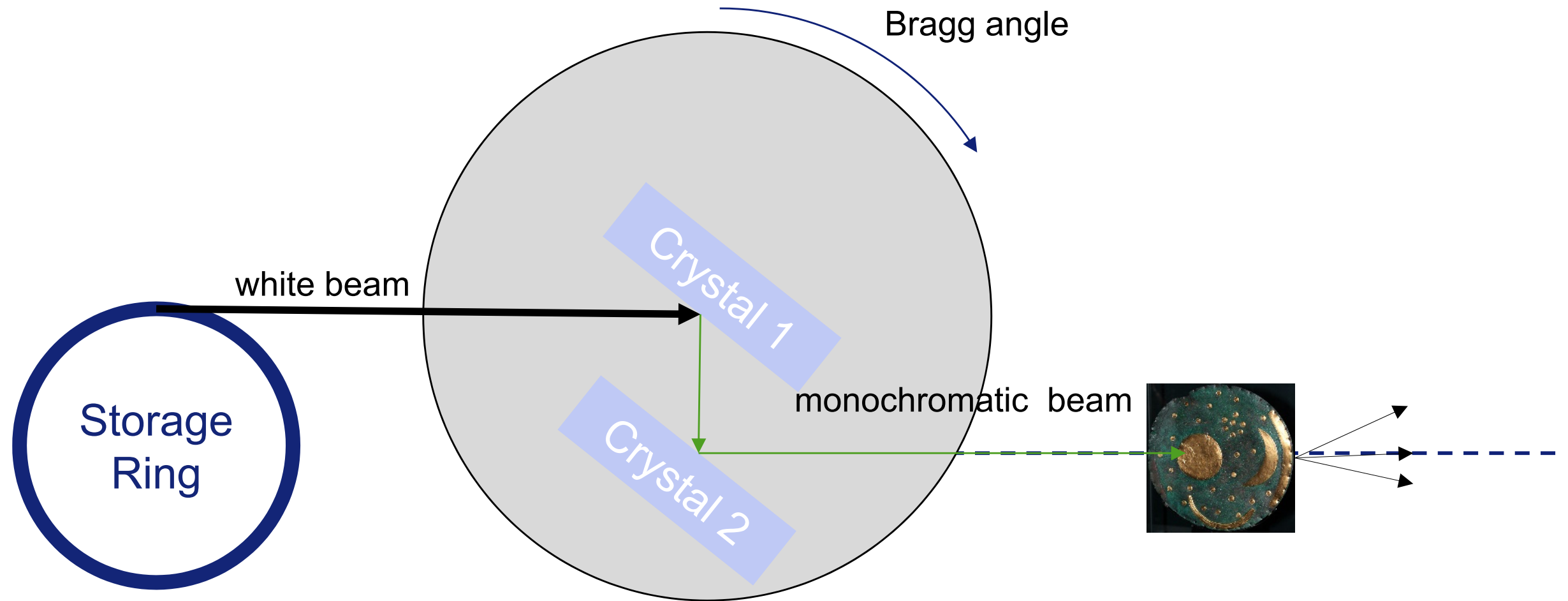

What does a Double Crystal Monochromator?

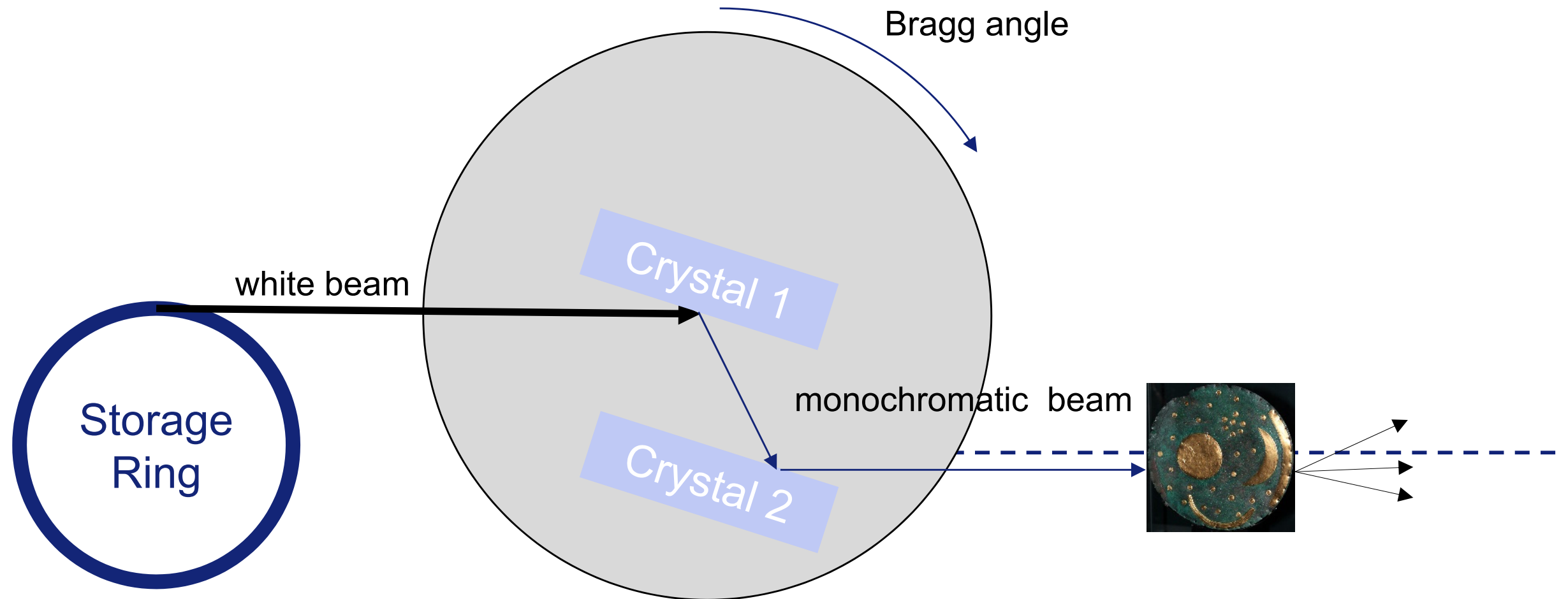

What does a Double Crystal Monochromator?

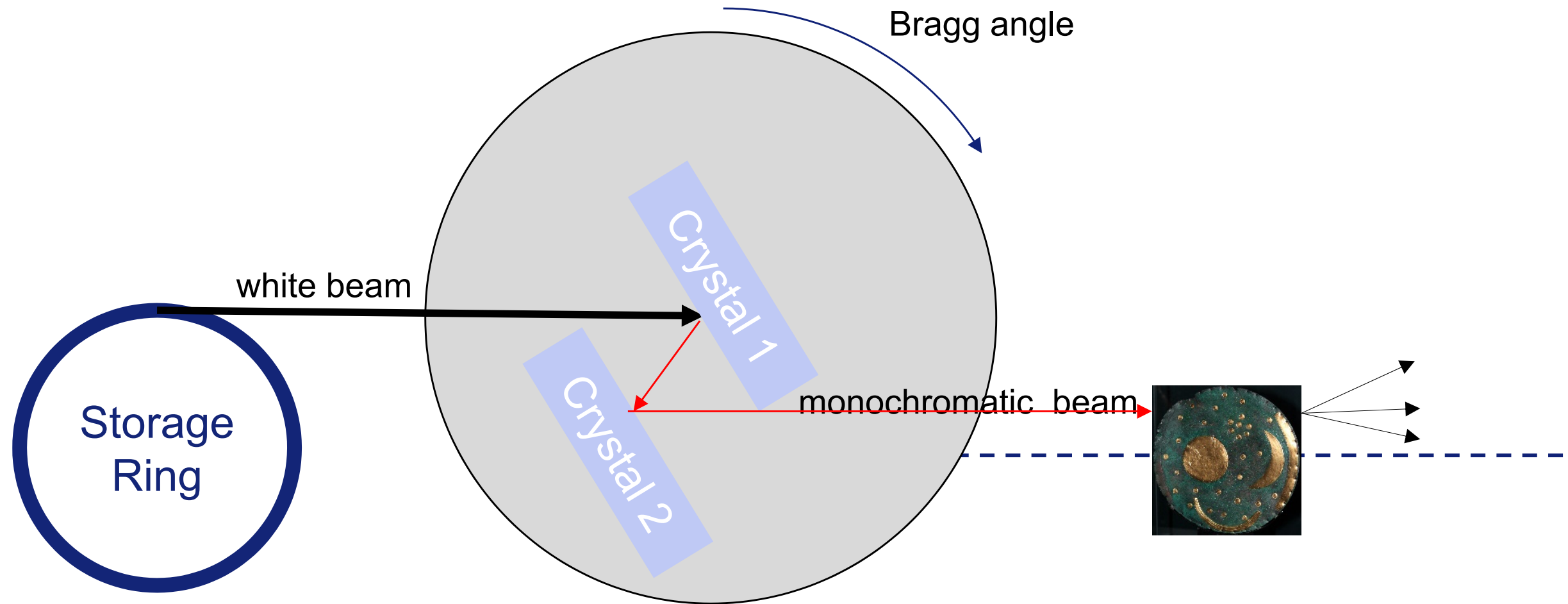

What does a Double Crystal Monochromator?

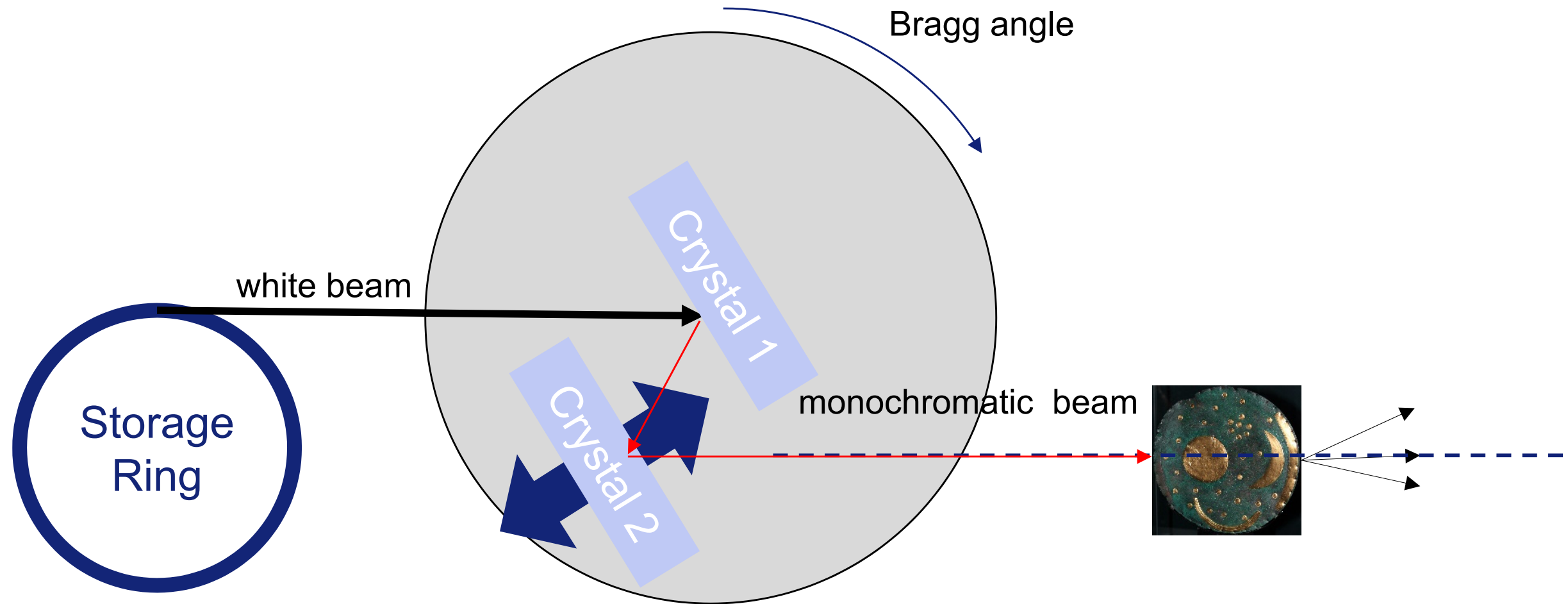

What does a Double Crystal Monochromator?

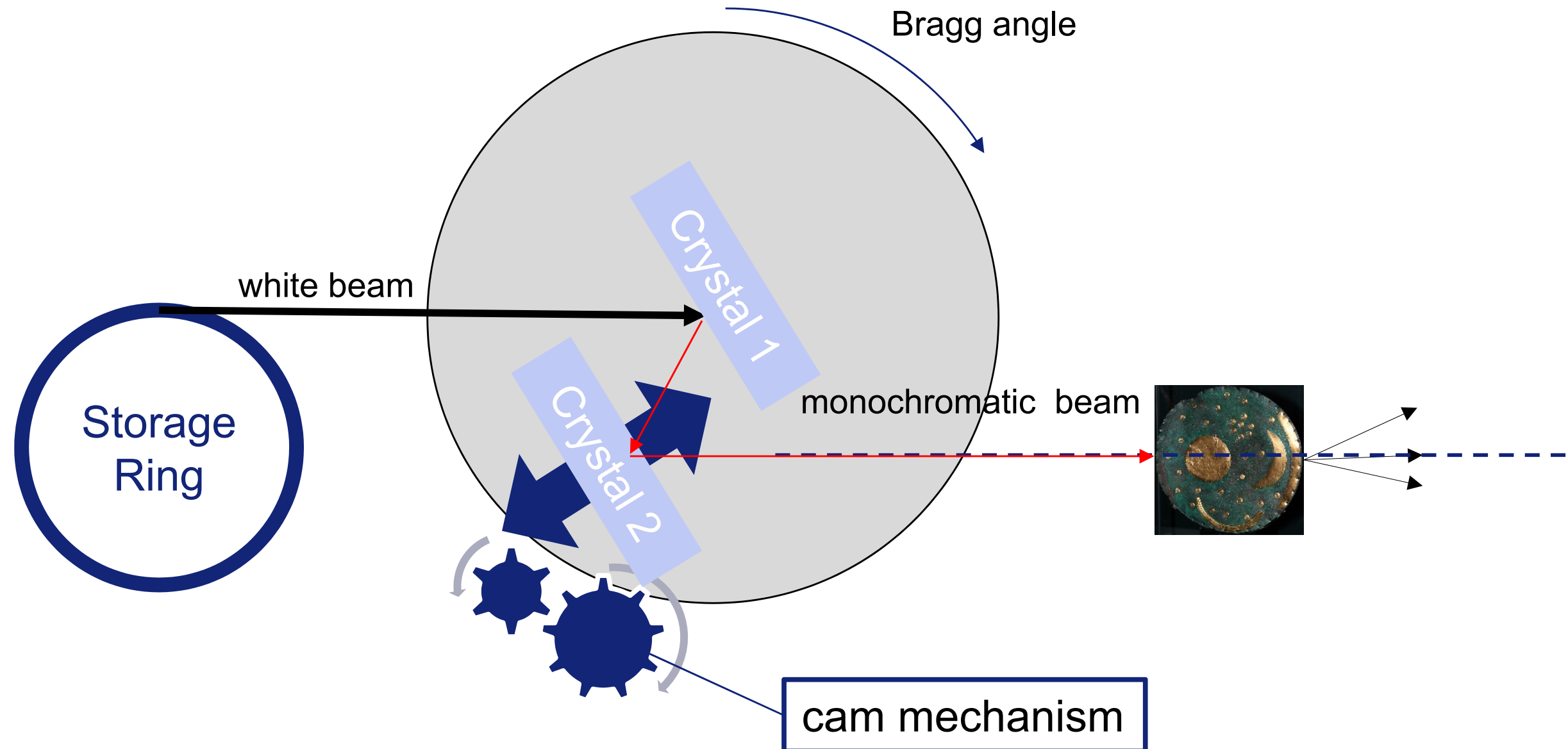

What does a Double Crystal Monochromator?

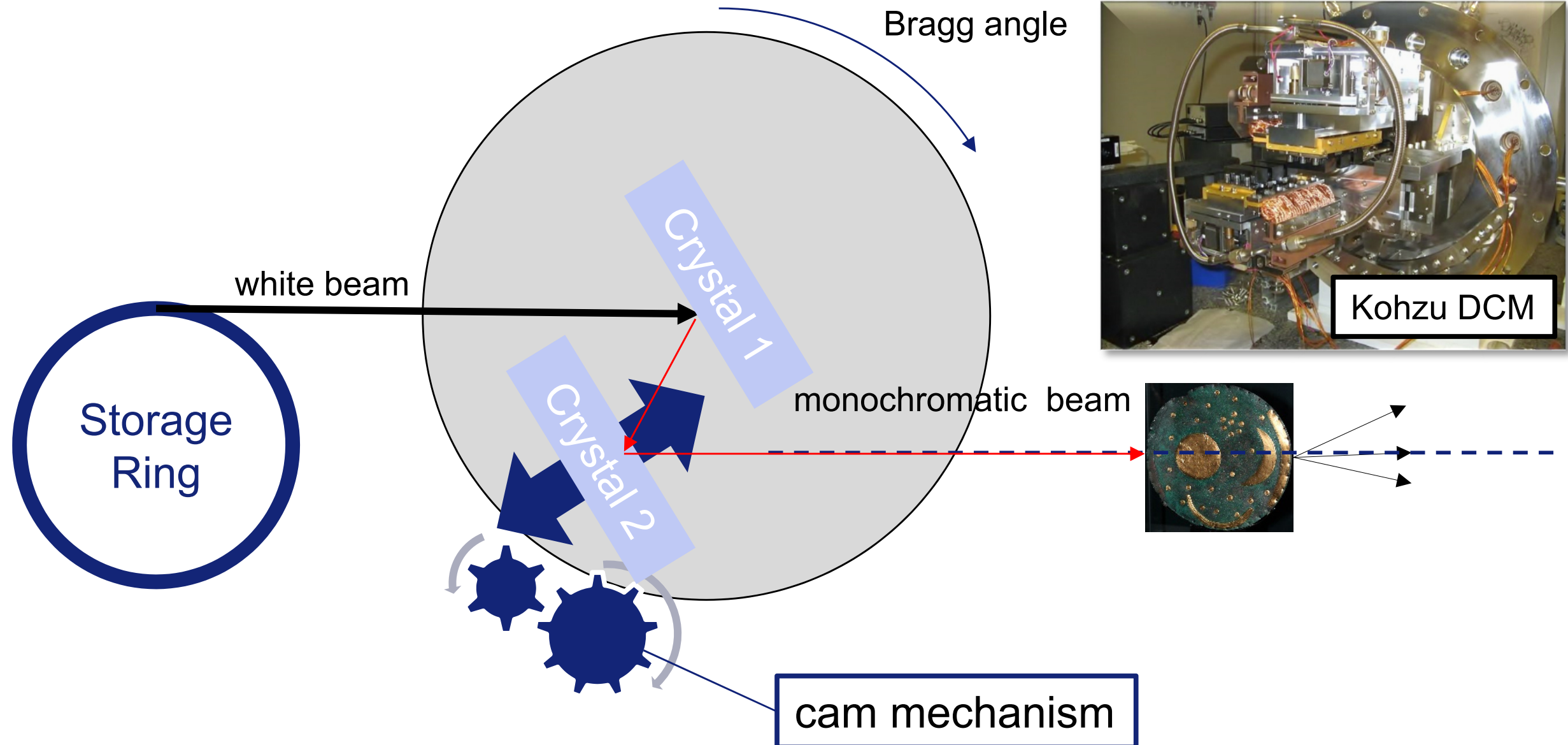

The ESRF-DCM prototype

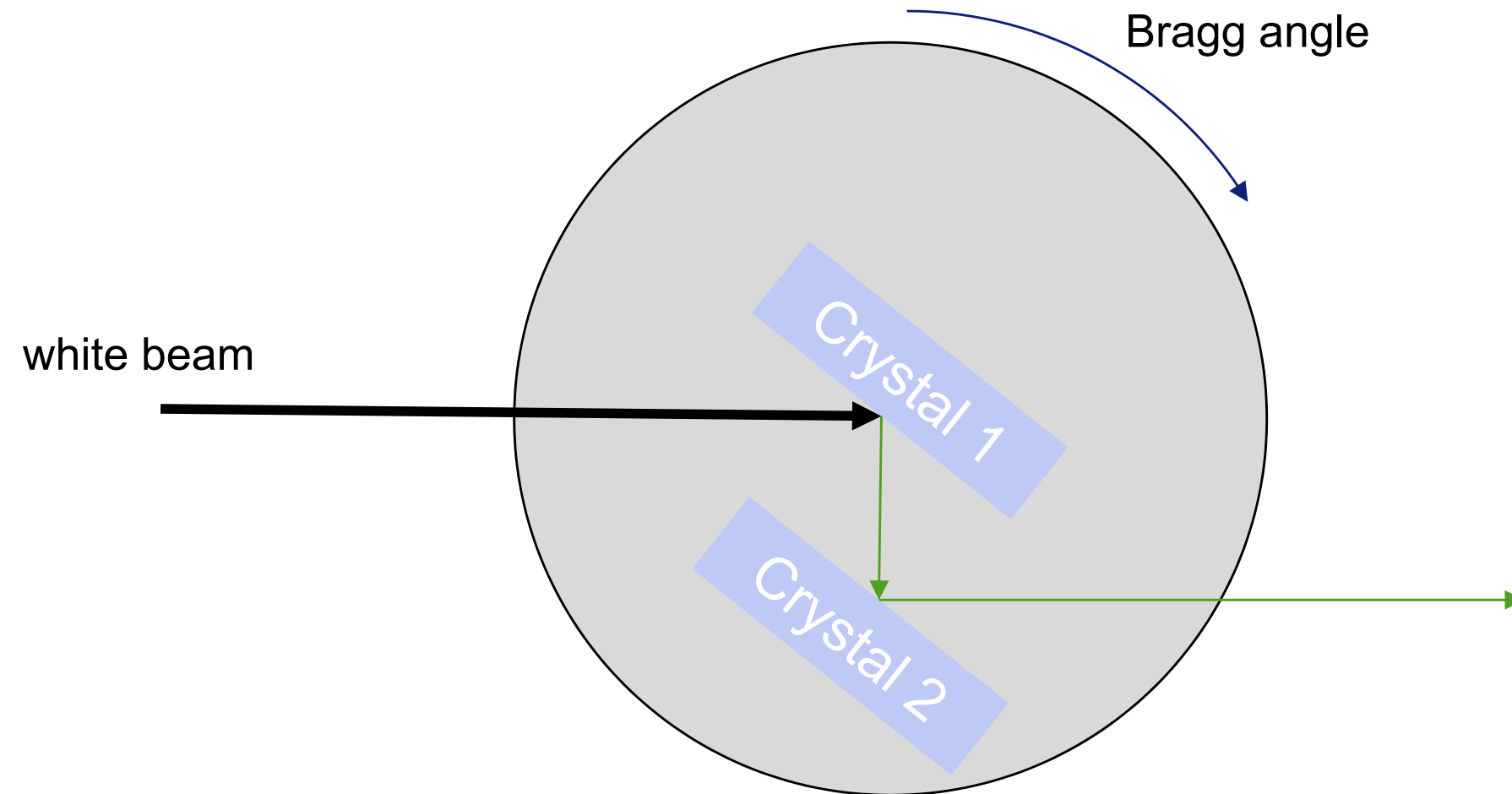

The ESRF-DCM prototype

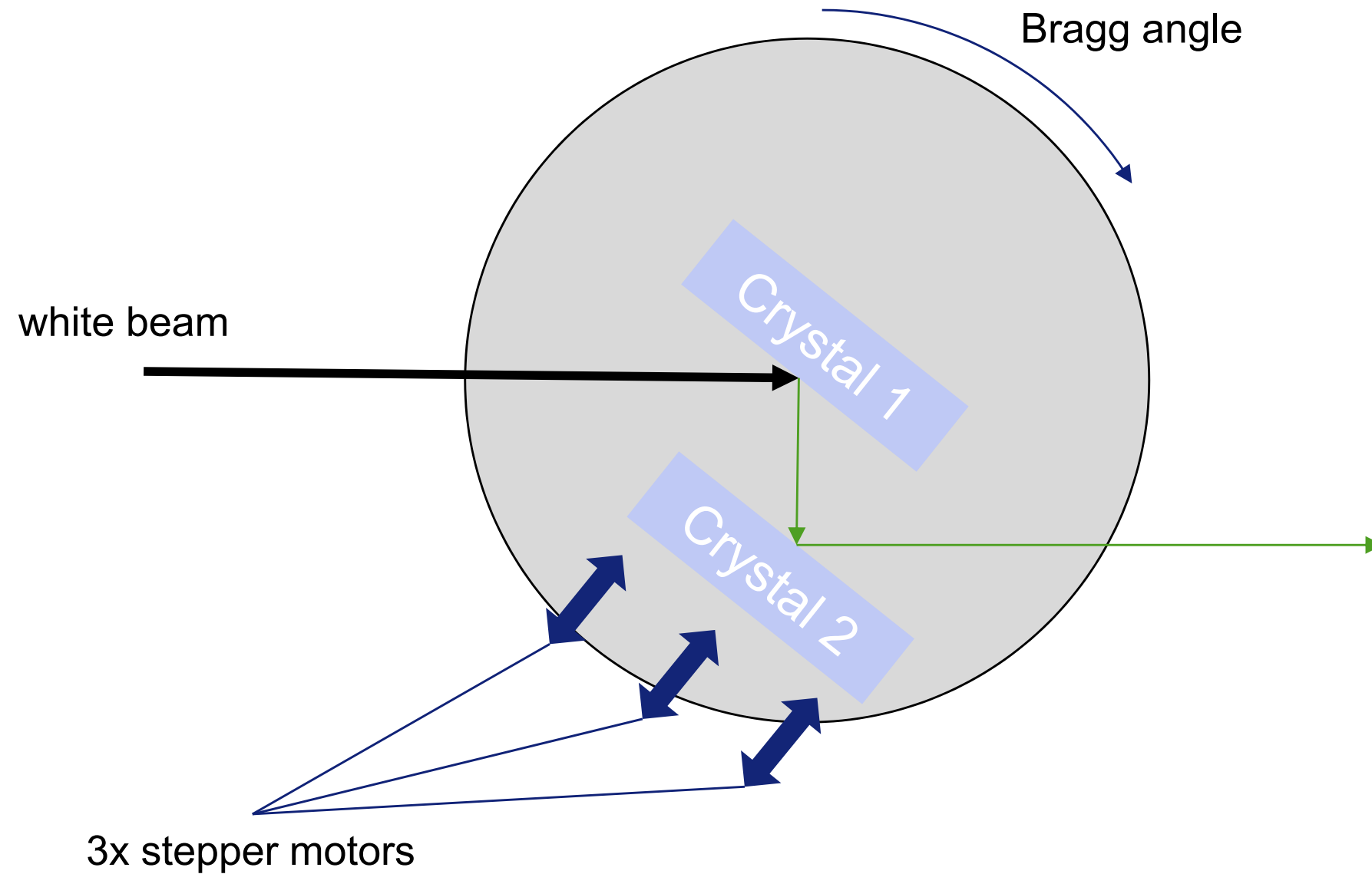

The ESRF-DCM prototype

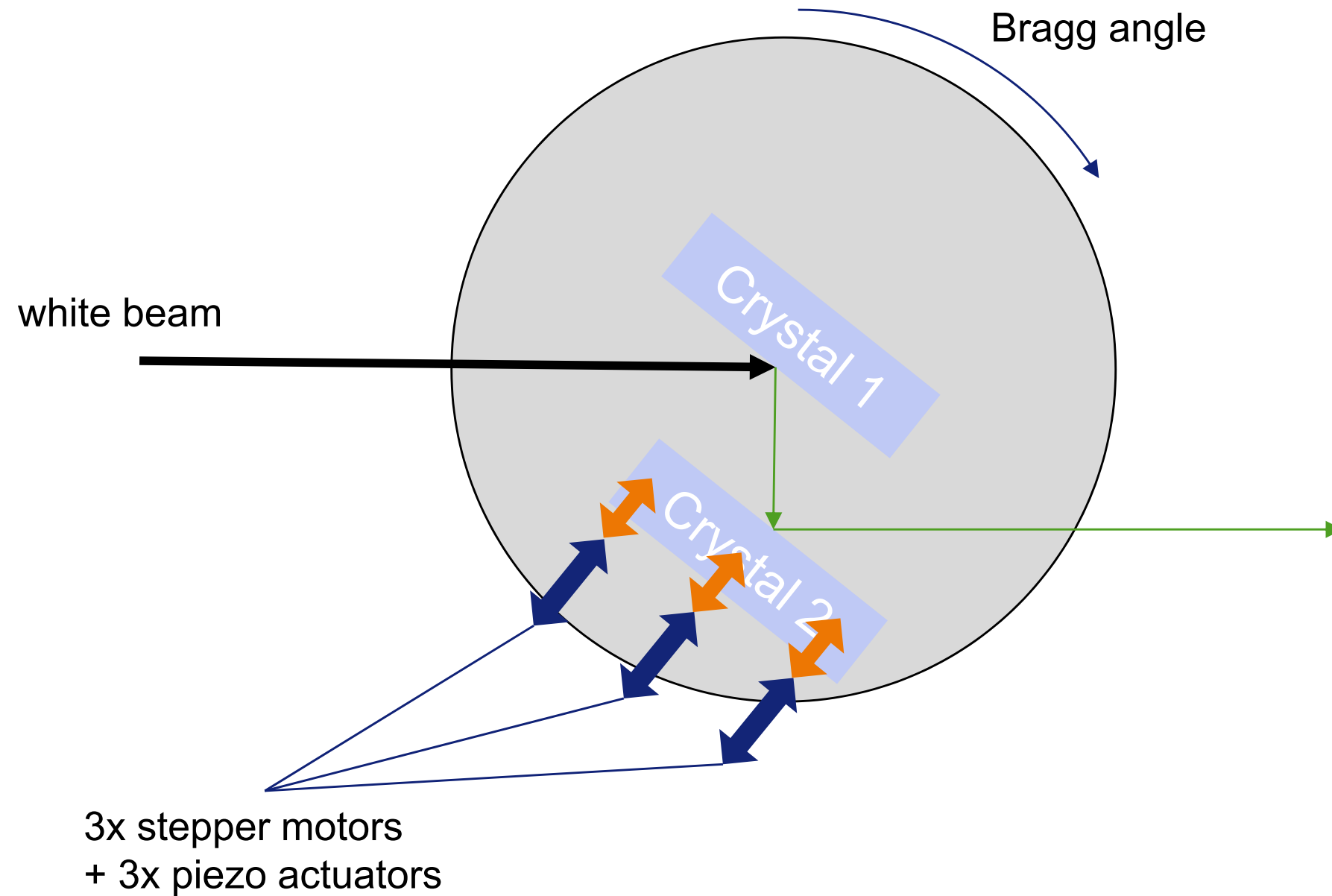

The SRF-DCM prototype

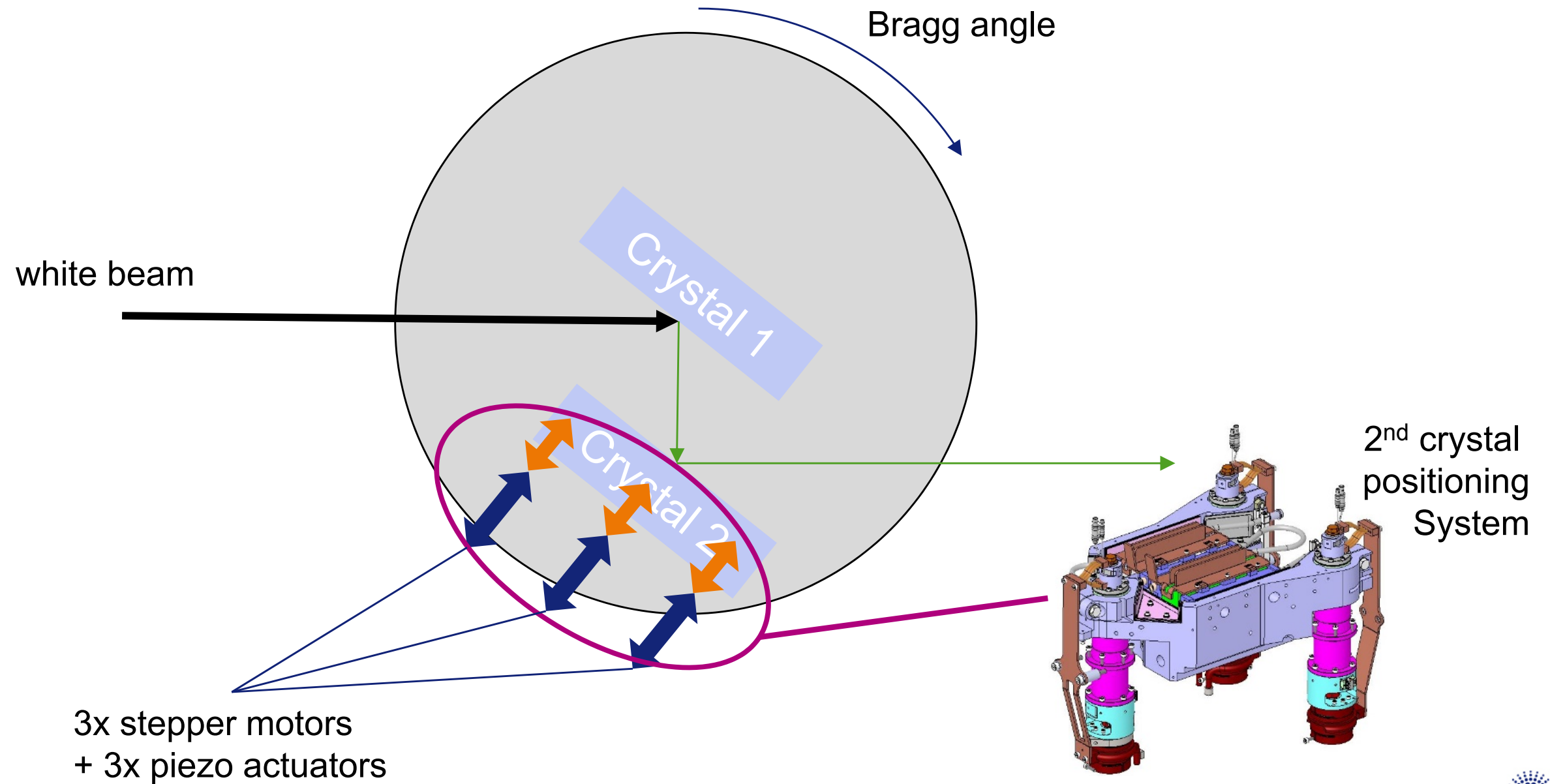

The ESRF-DCM prototype

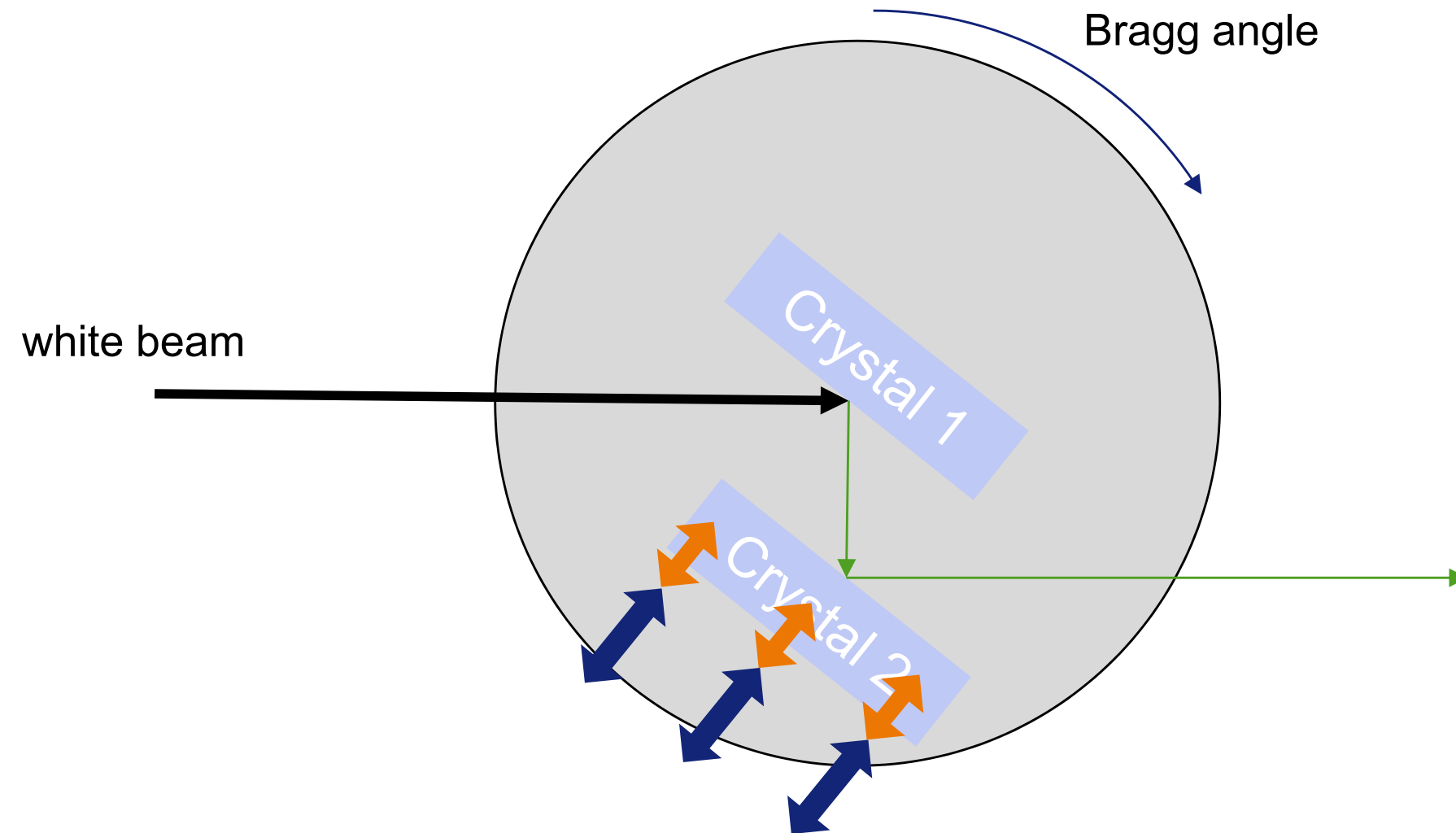

The ESRF-DCM prototype

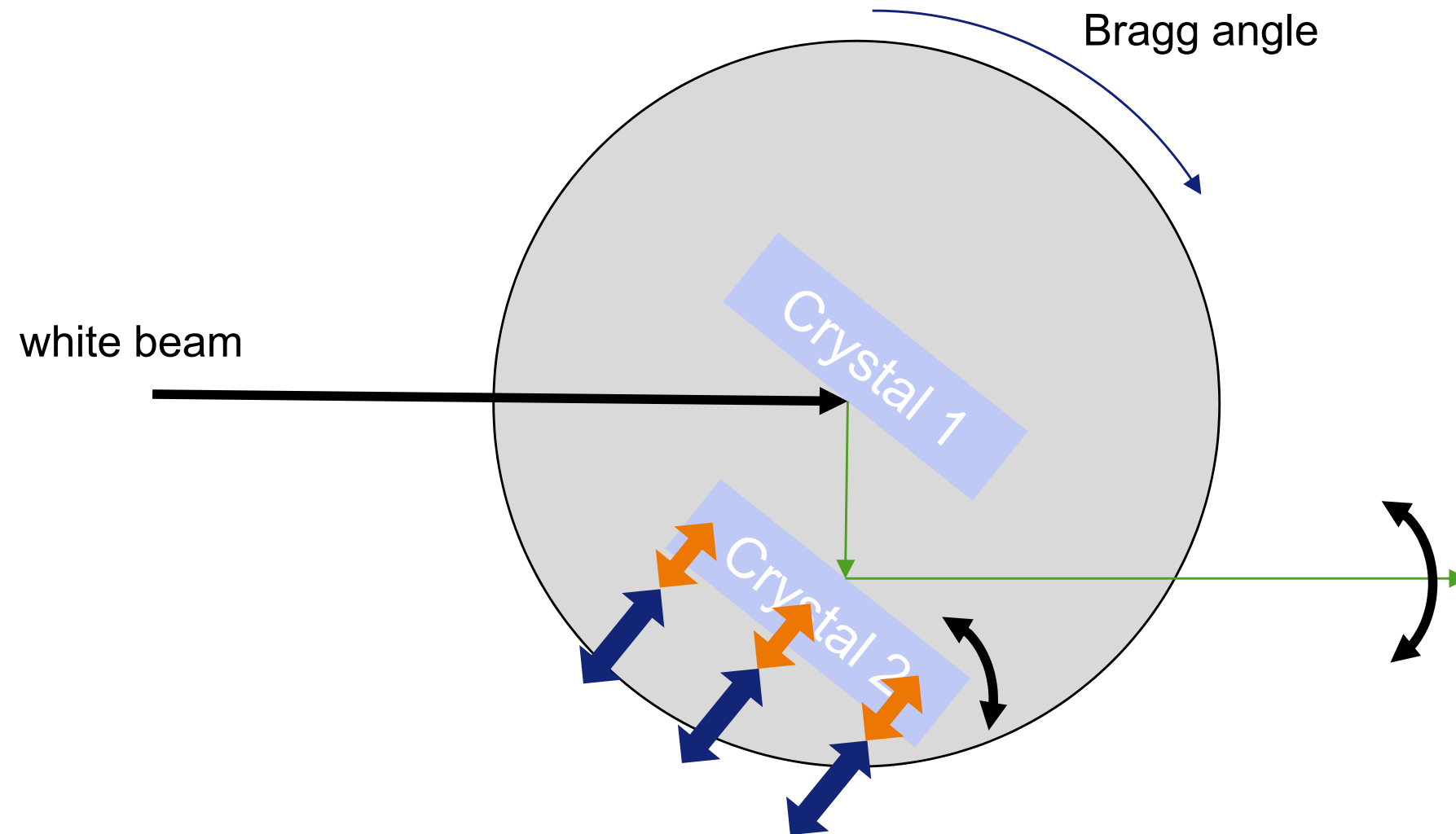

The ESRF-DCM prototype

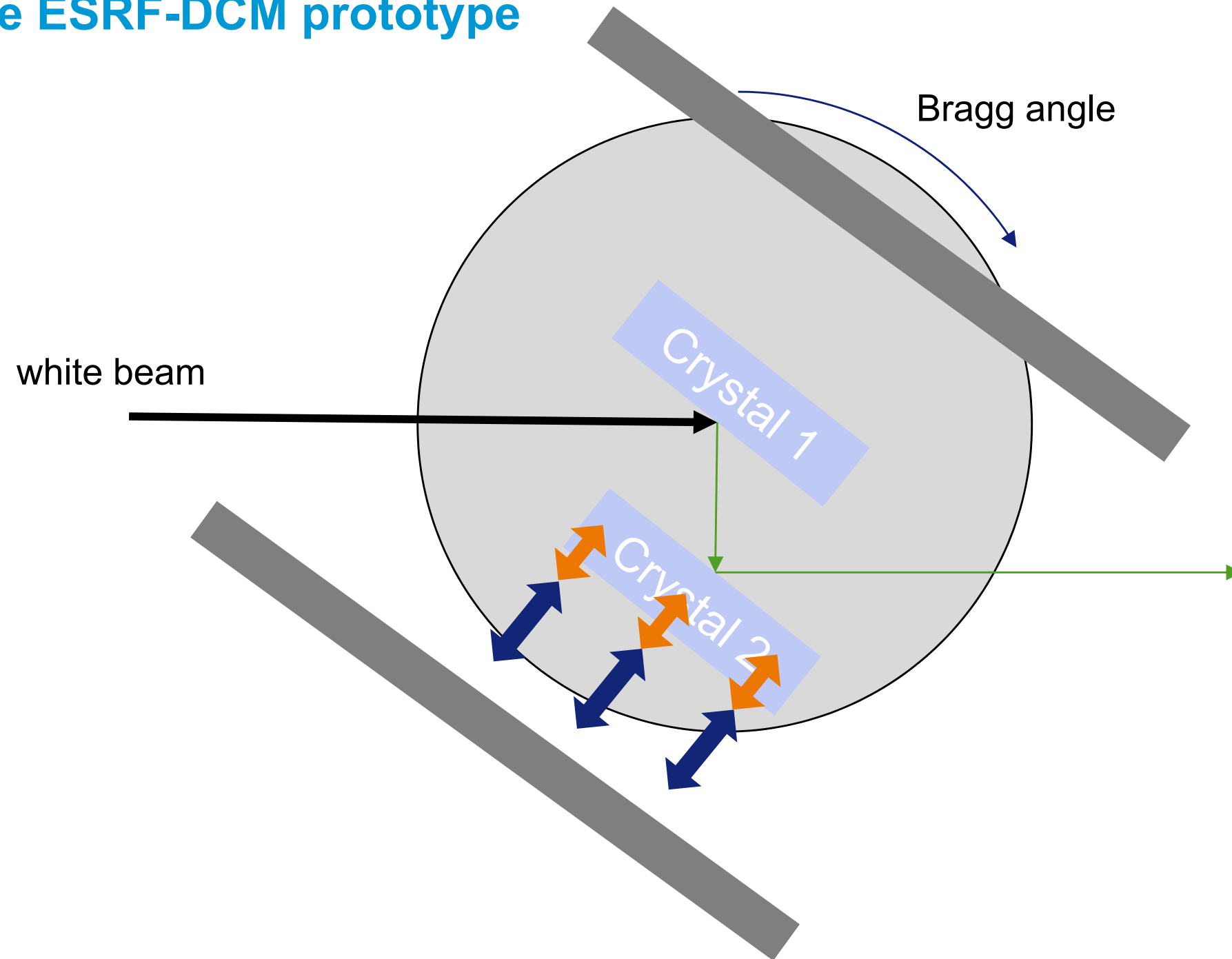

The ESRF-DCM prototype

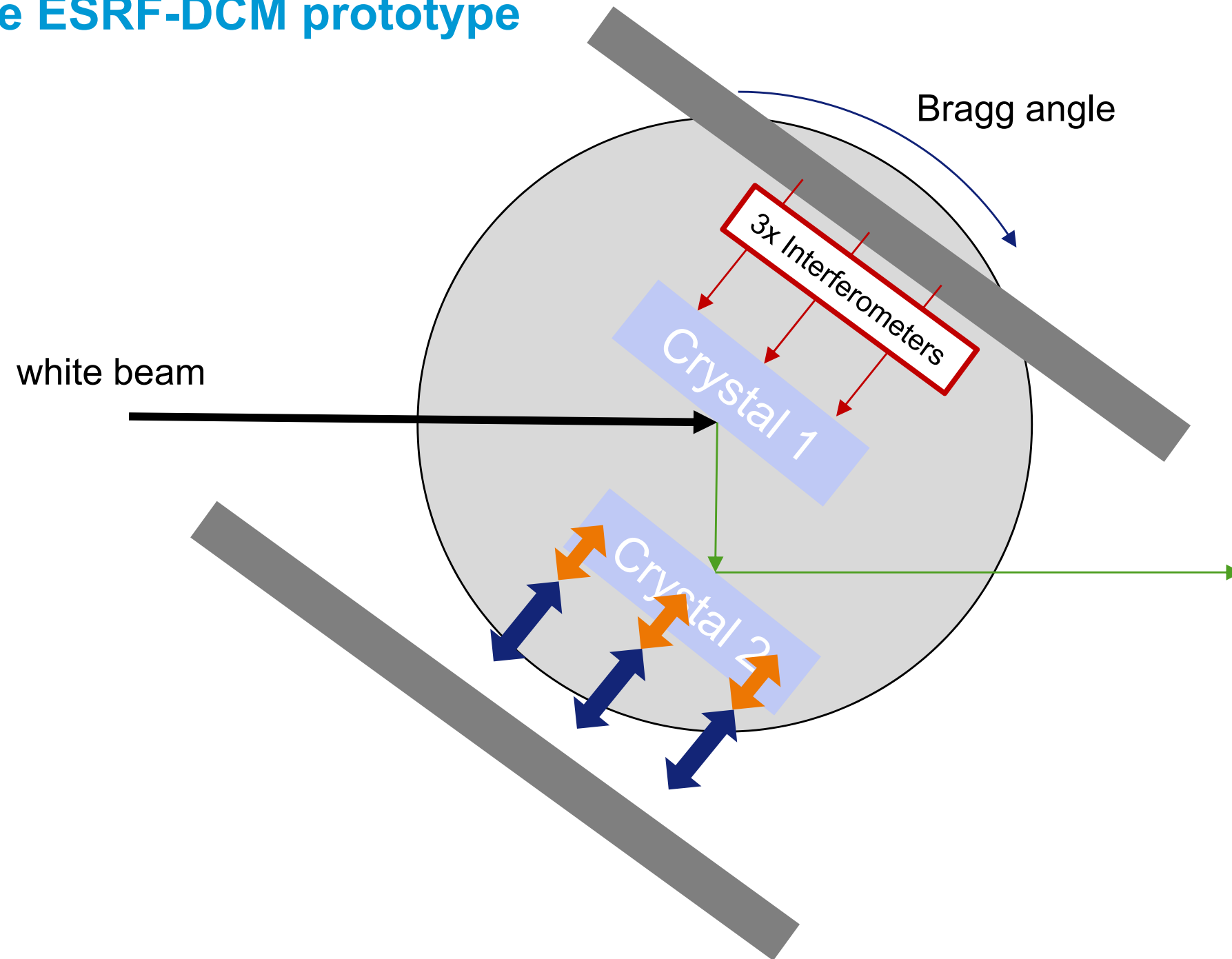

The ESRF-DCM prototype

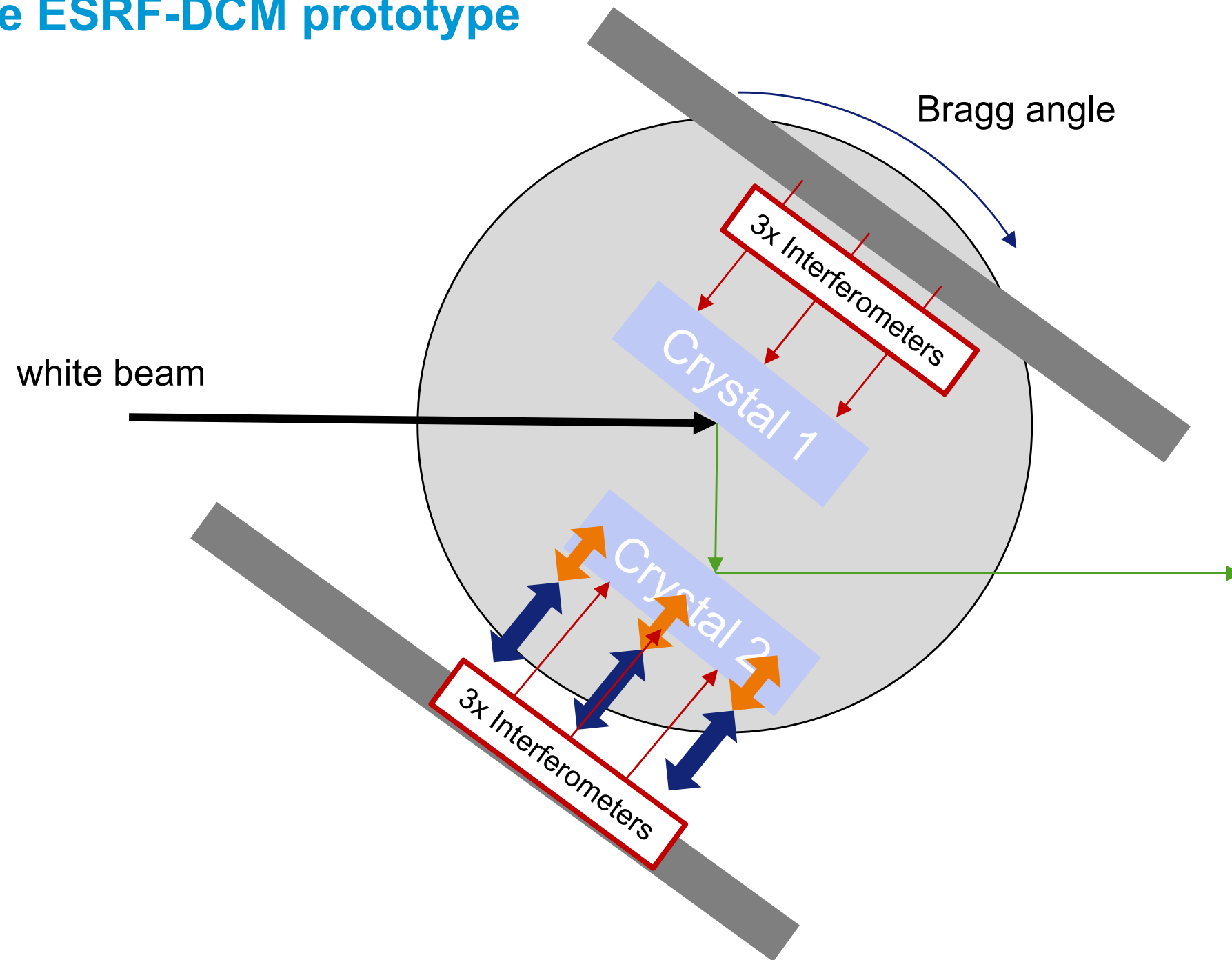

The ESRF-DCM prototype

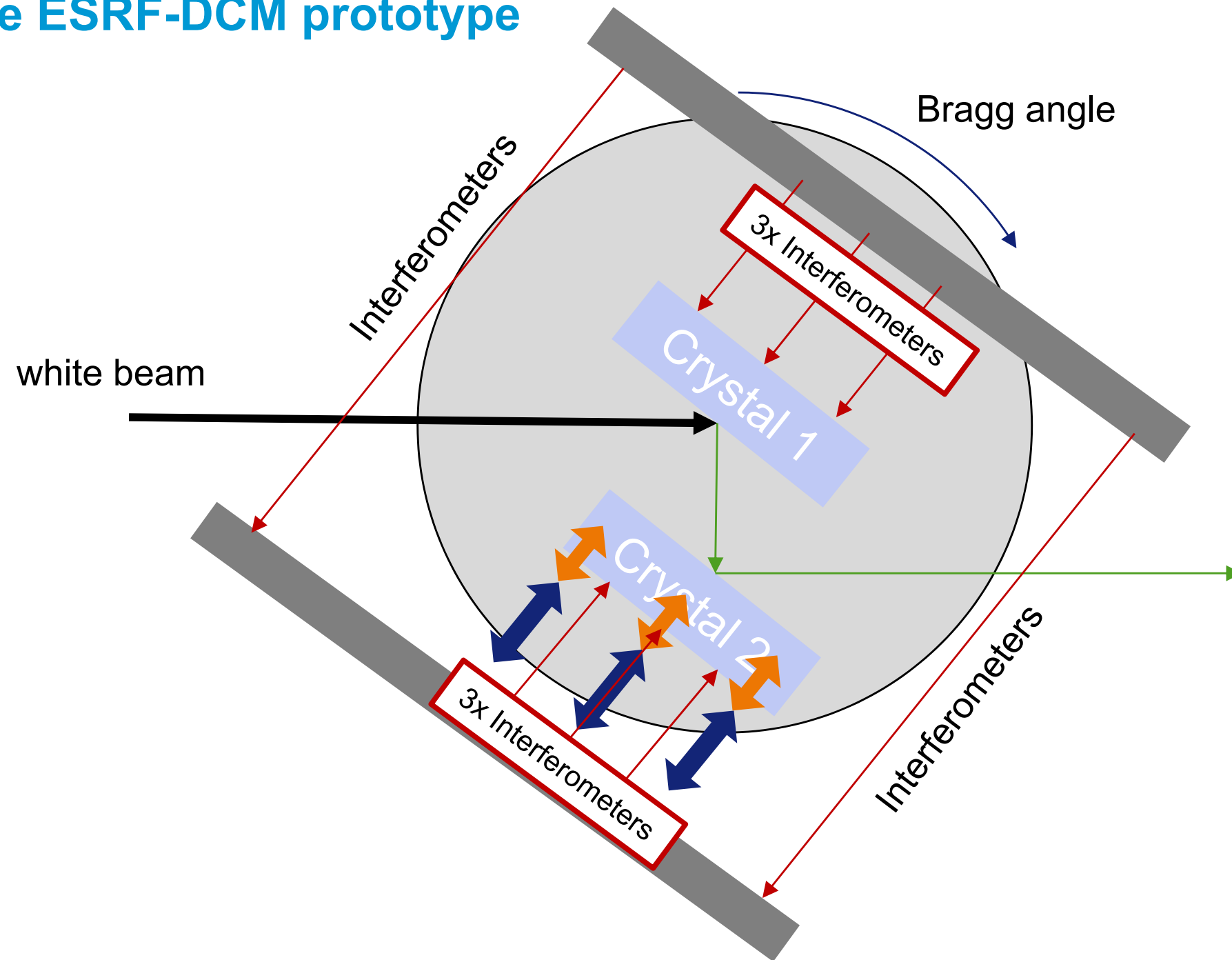

The ESRF-DCM prototype

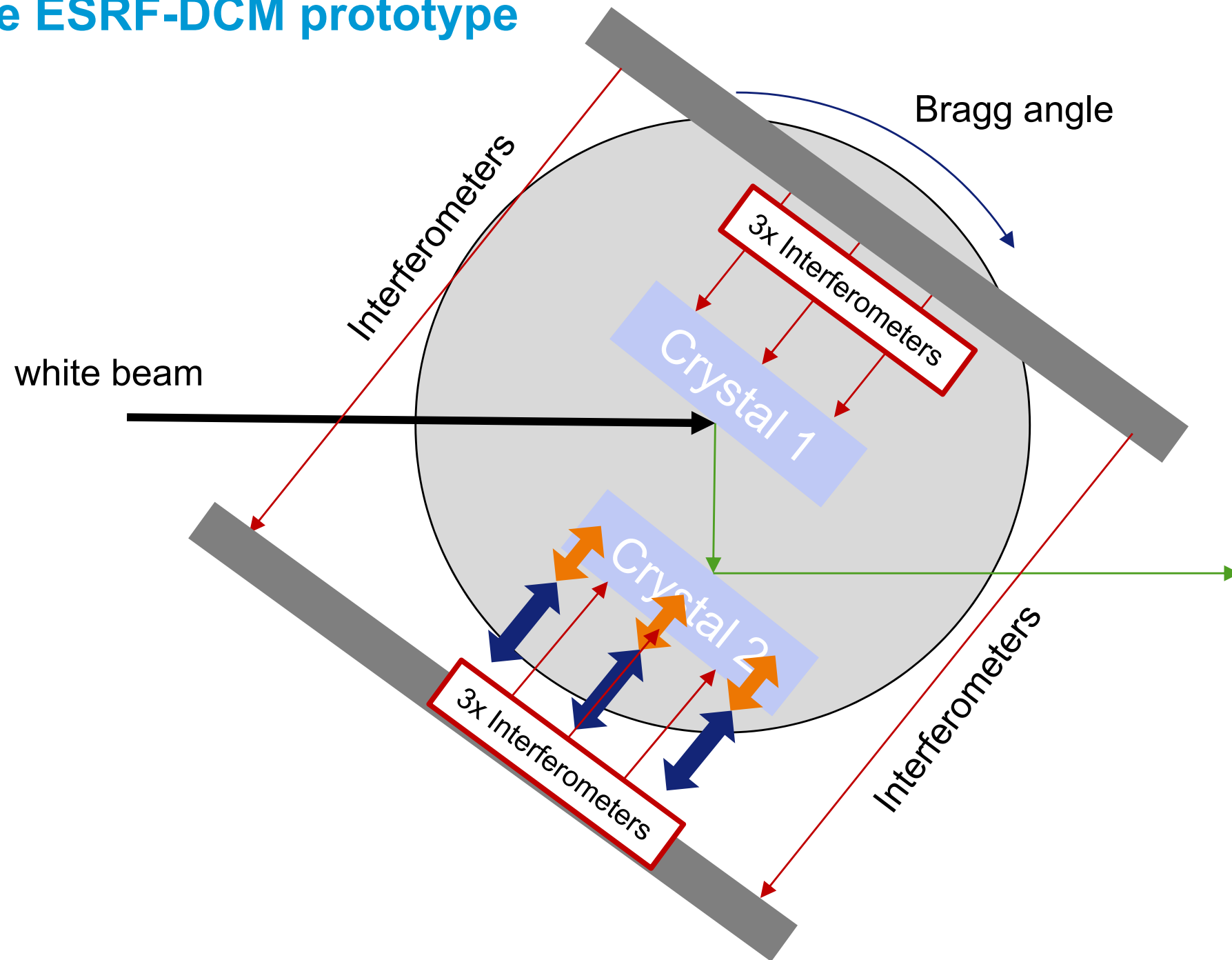

metrology frame

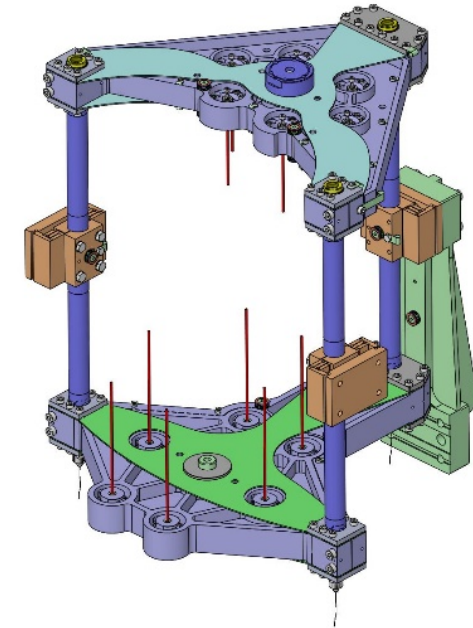

1. INTRODUCTION DCM

The ESRF-DCM prototype

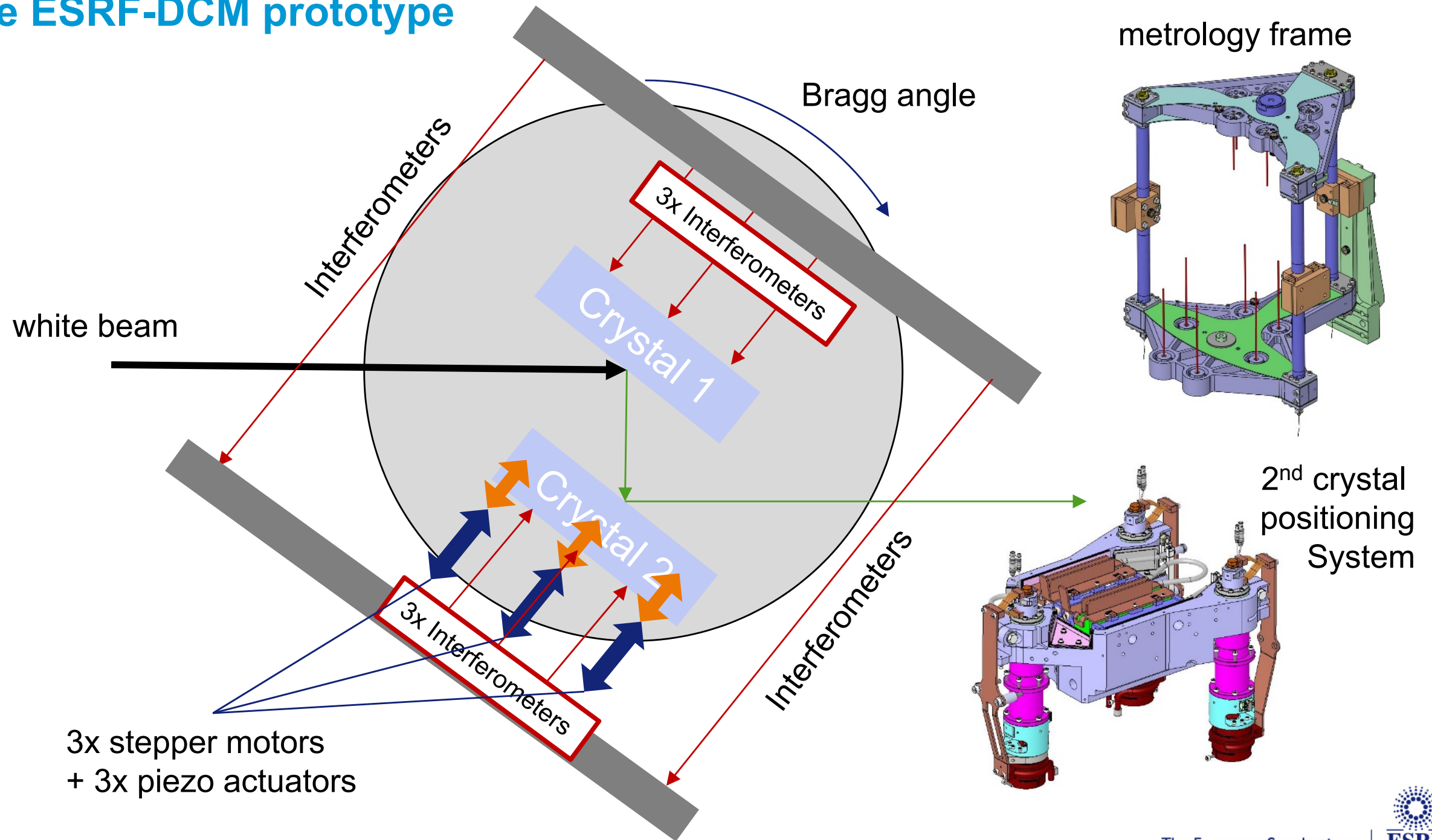

2. THE CONTROL CONCEPT

The ESRF-DCM prototype

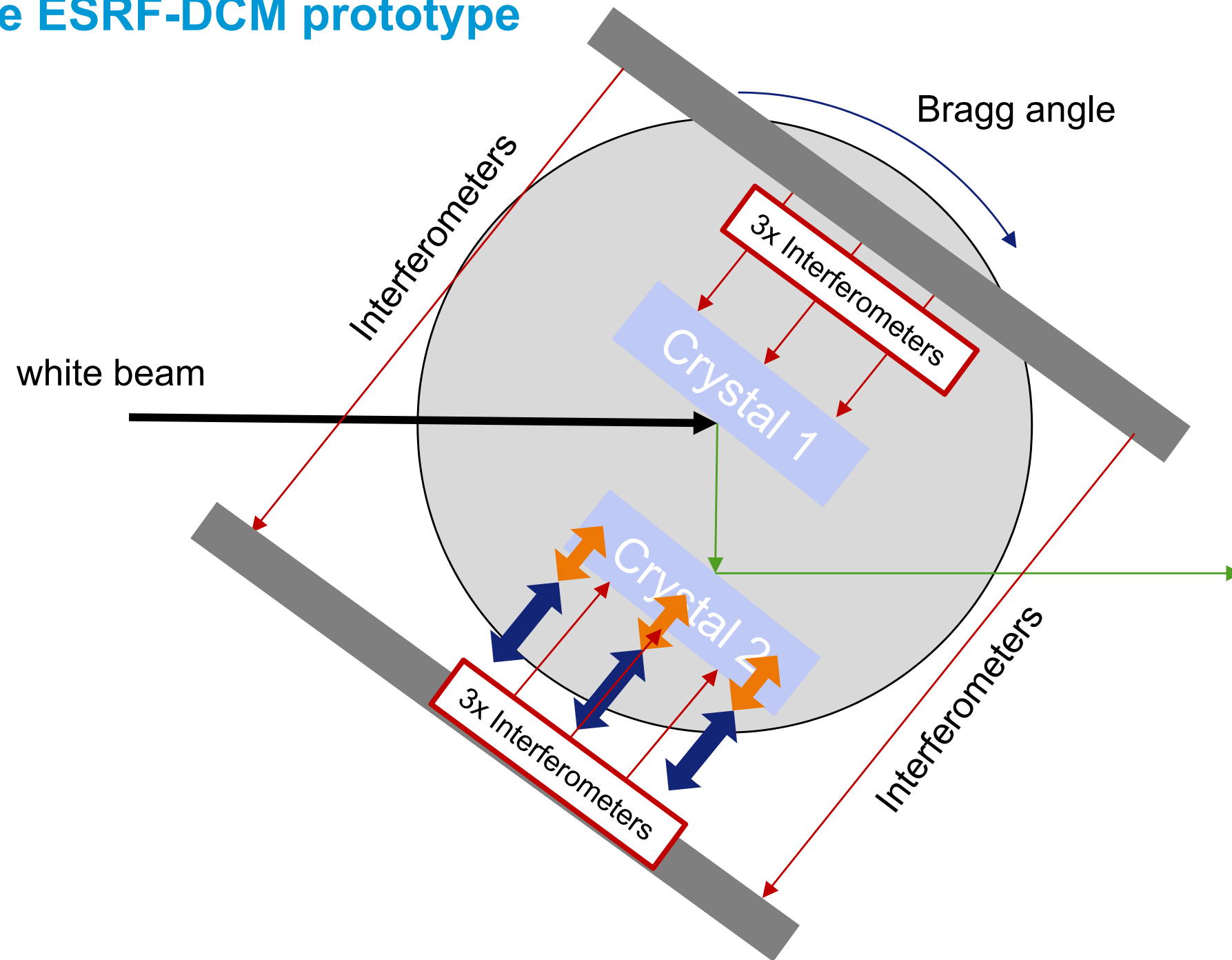

2. THE CONTROL CONCEPT

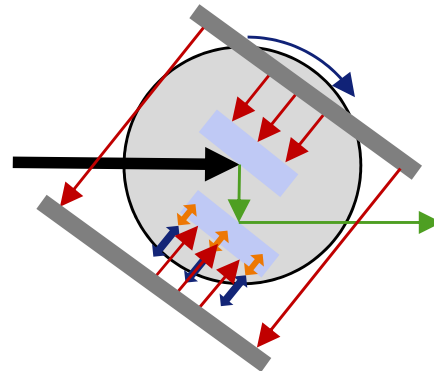

2. THE CONTROL CONCEPT

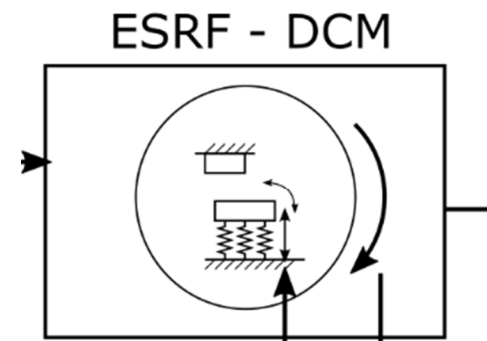

2. THE CONTROL CONCEPT

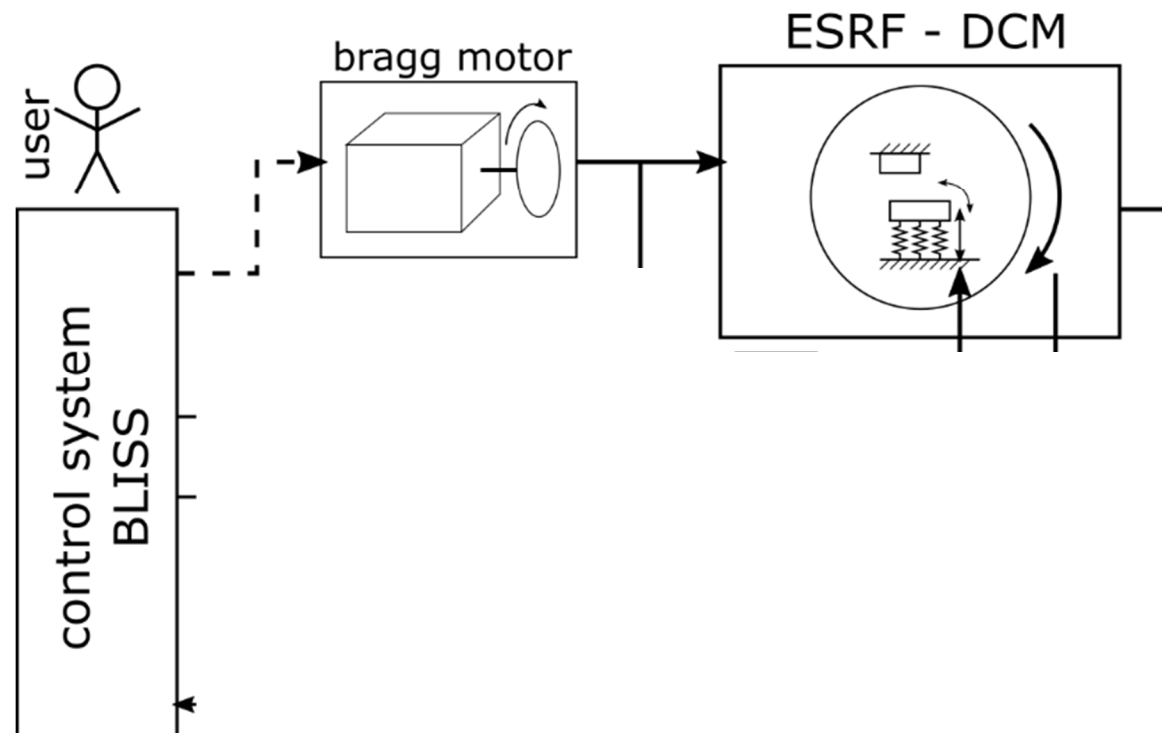

2. THE CONTROL CONCEPT

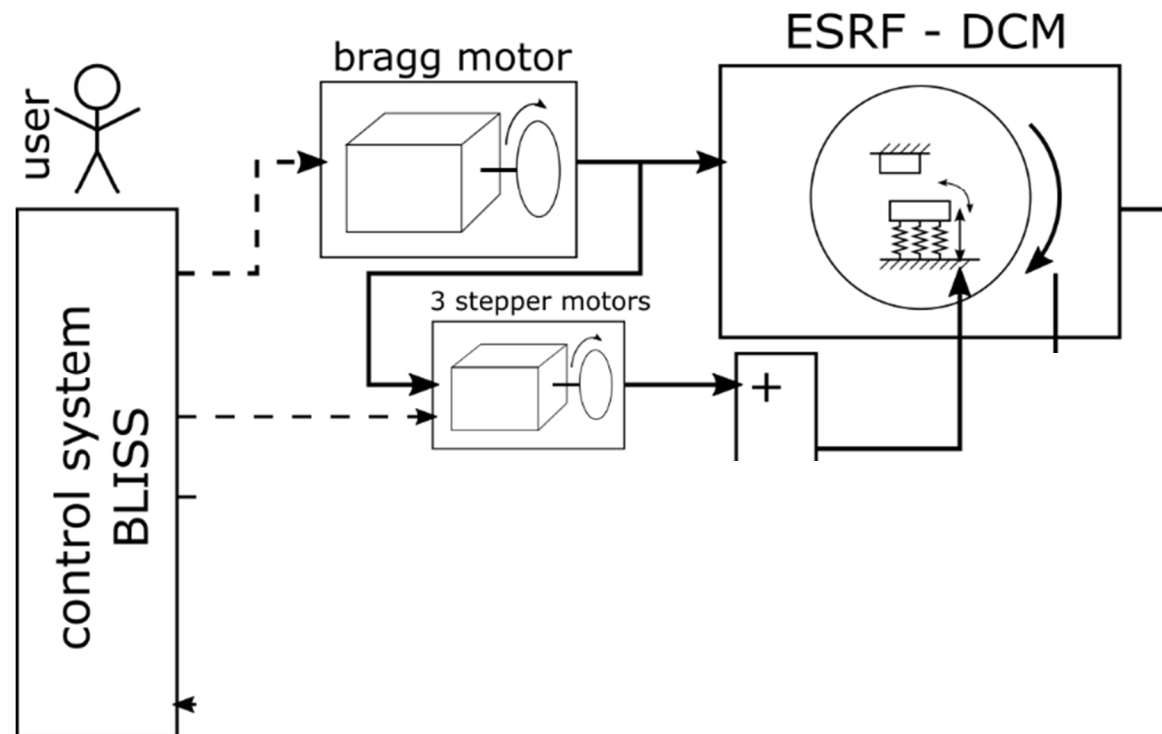

2. THE CONTROL CONCEPT

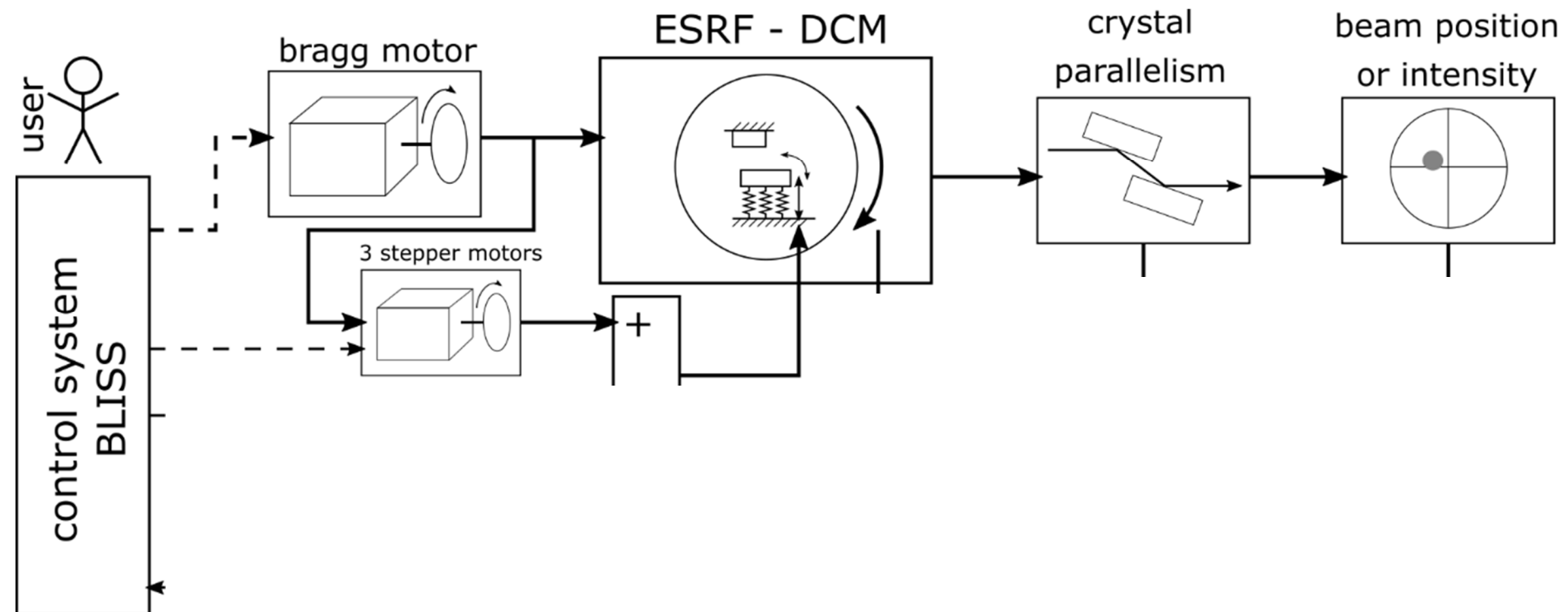

2. THE CONTROL CONCEPT

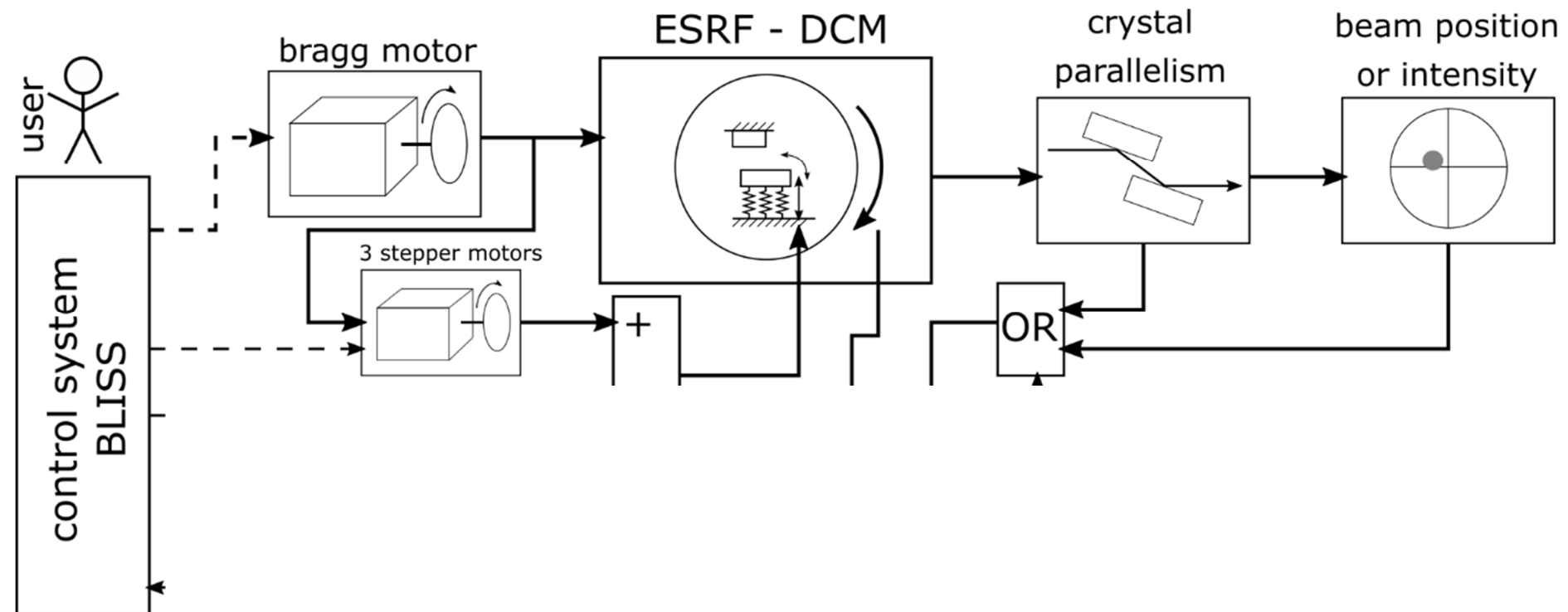

2. THE CONTROL CONCEPT

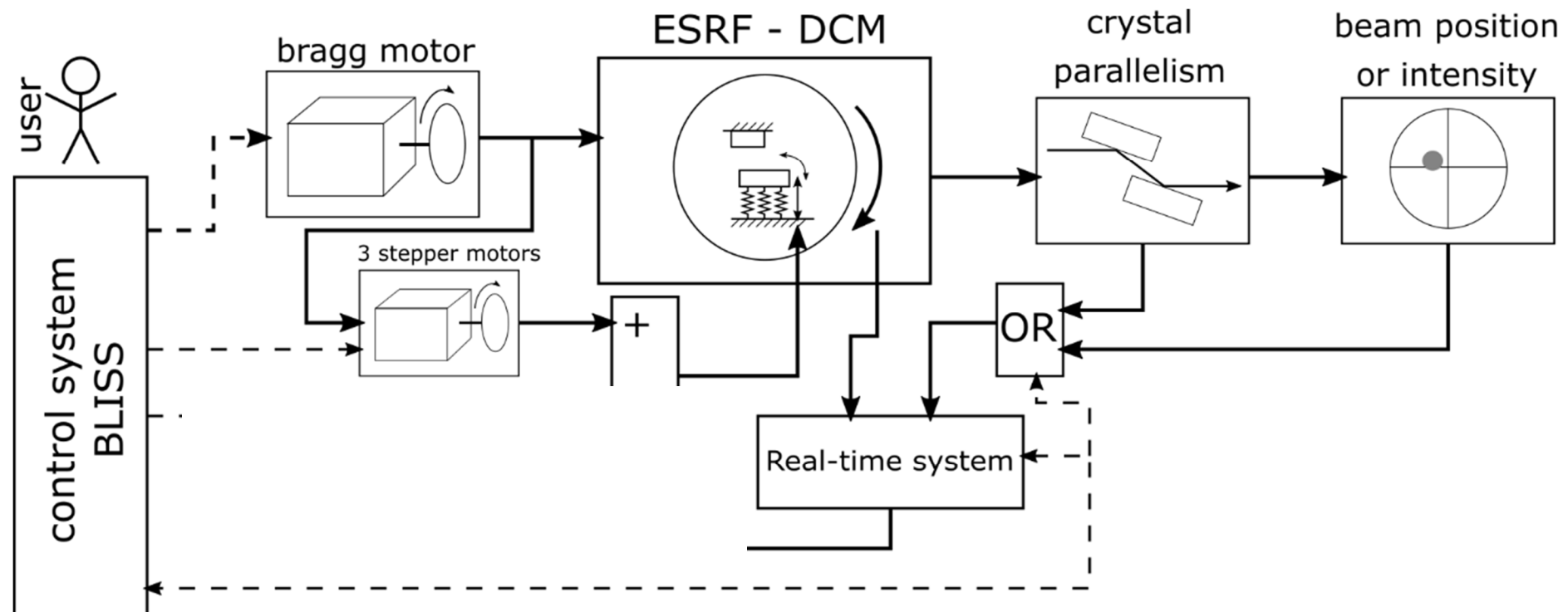

2. THE CONTROL CONCEPT

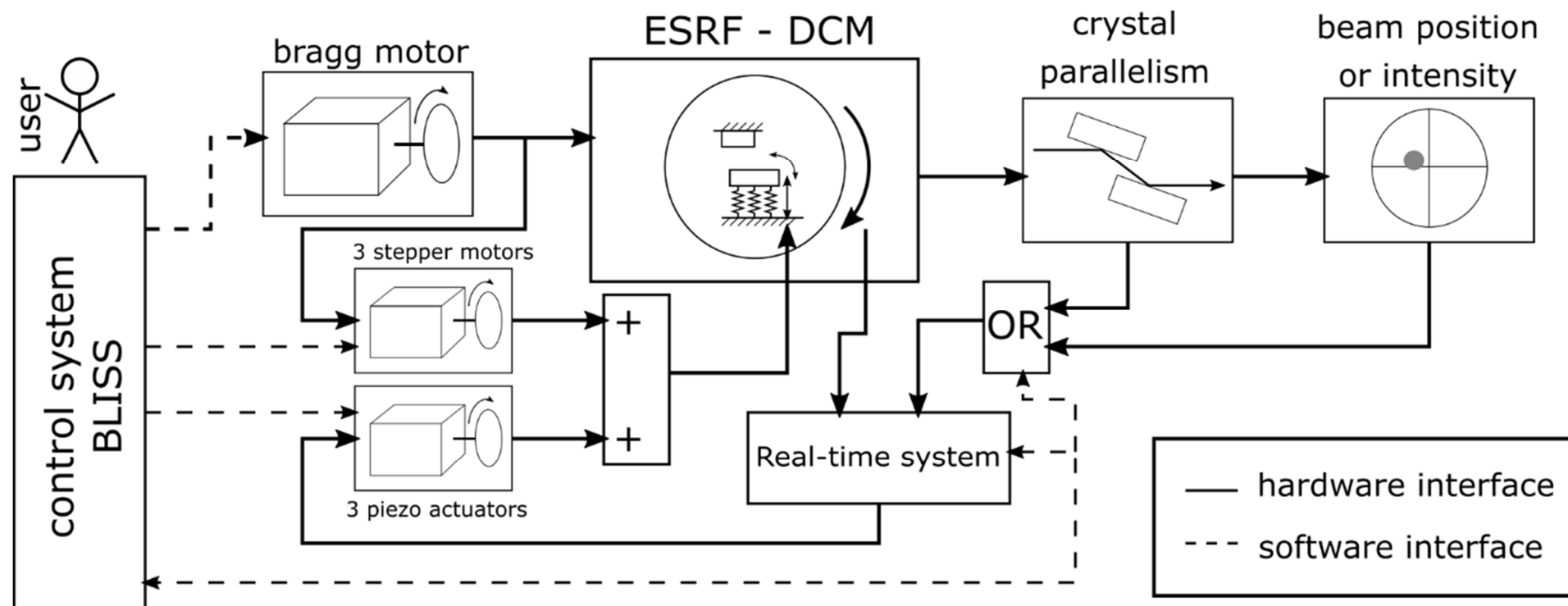

2. THE CONTROL CONCEPT

ESRF-DCM design principle in three modes:

- Mode A
- Mode B
- Mode C

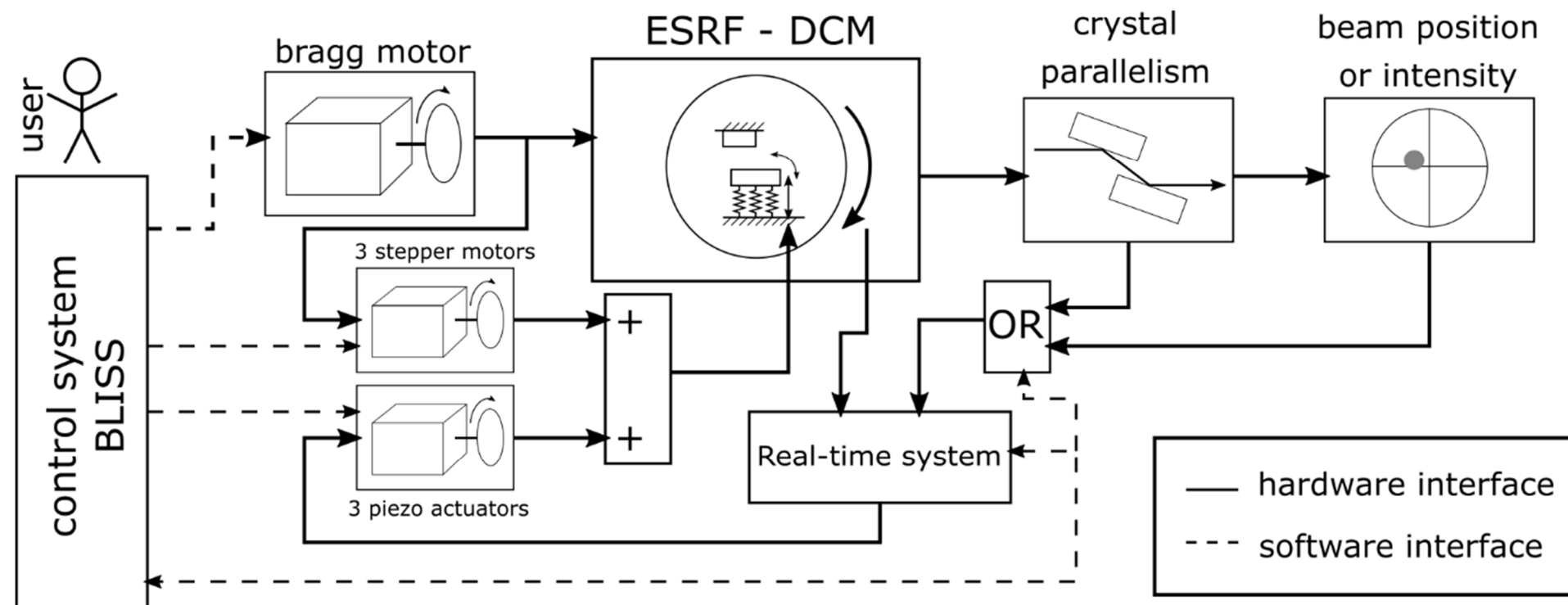

2. THE CONTROL CONCEPT

ESRF-DCM design principle in three modes:

- Mode A: No control loop

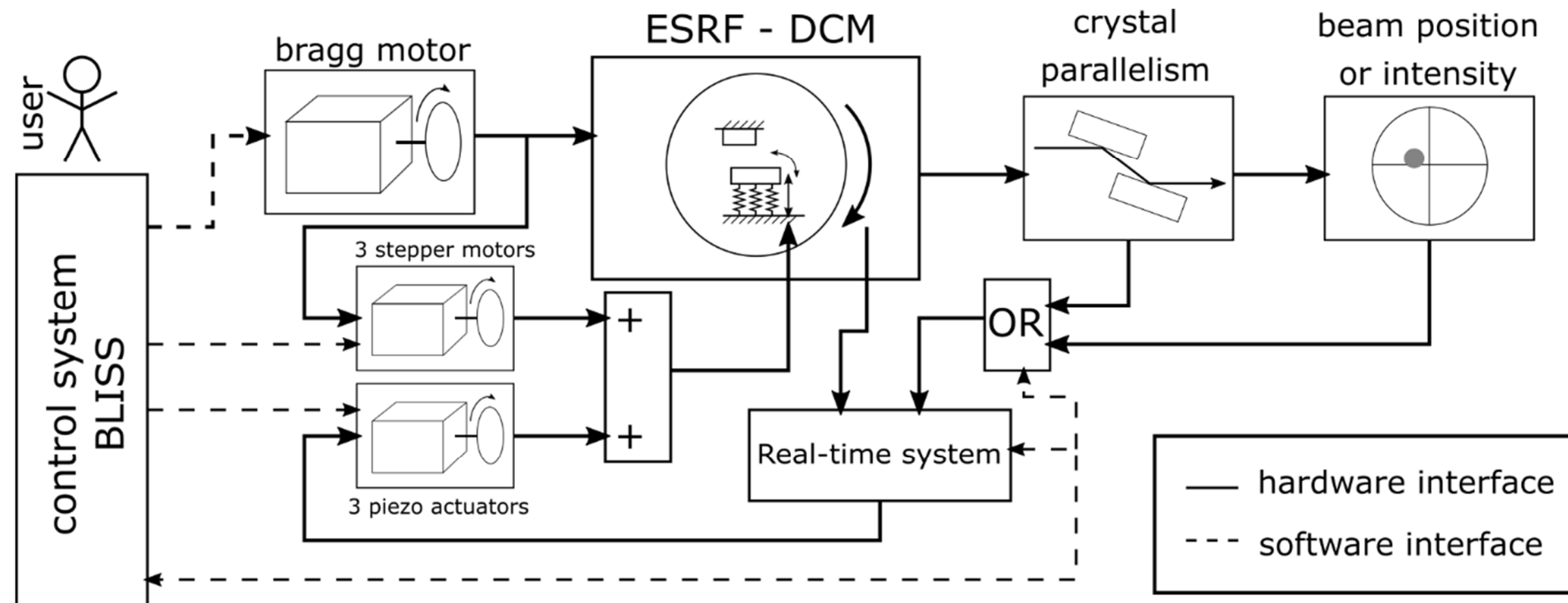
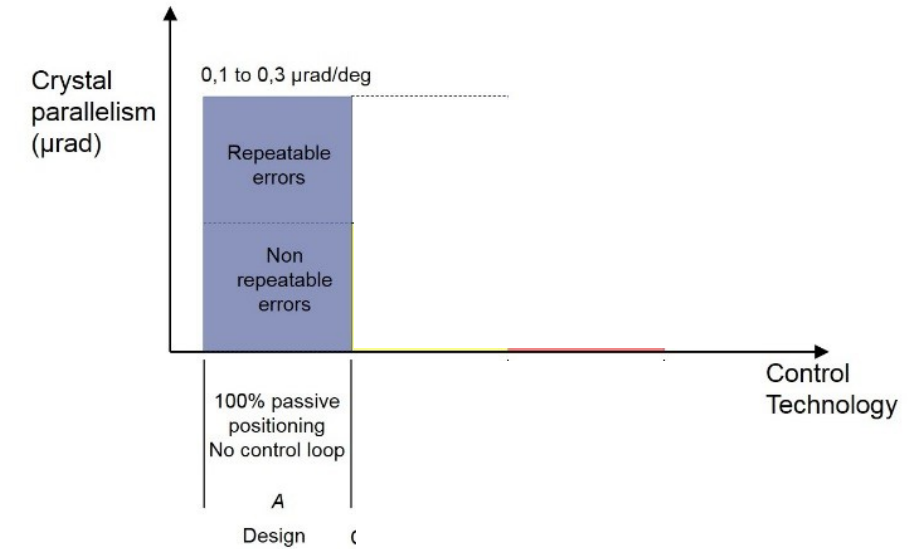

2. THE CONTROL CONCEPT

ESRF-DCM design principle in three modes:

- Mode A: No control loop

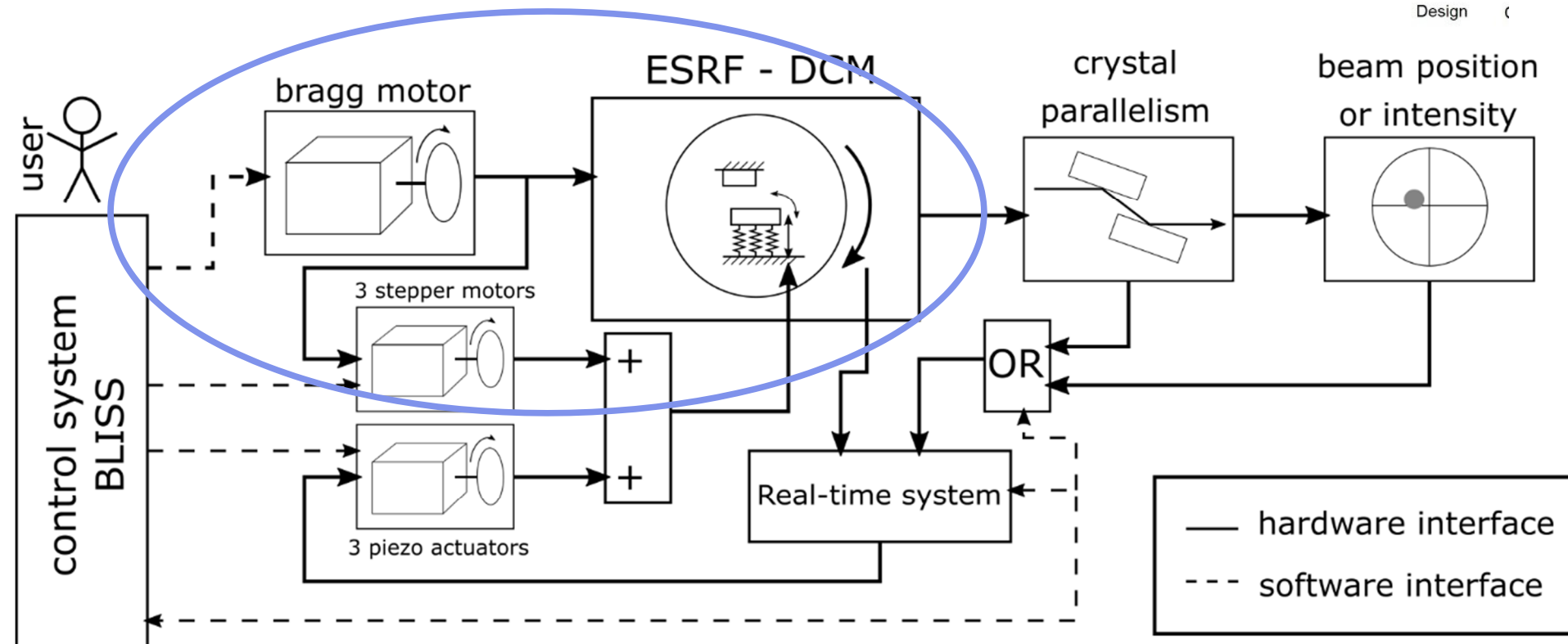
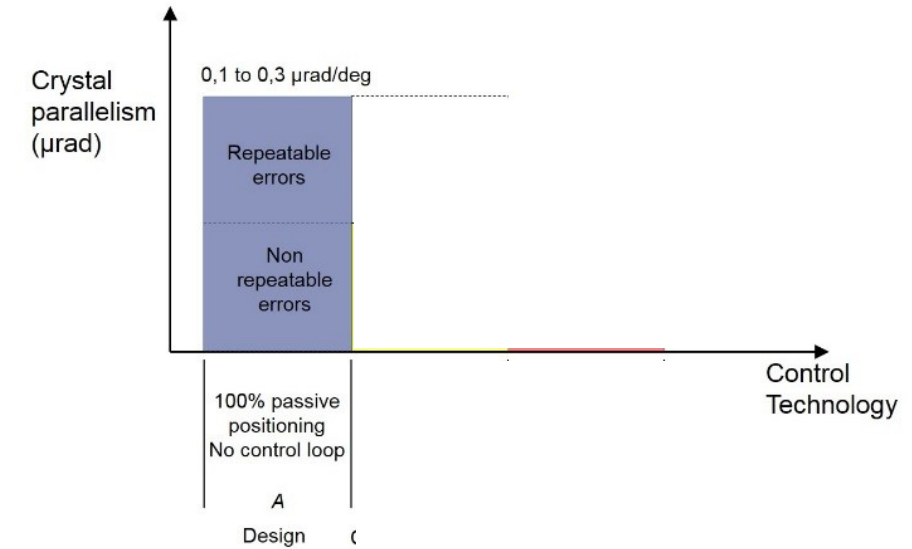

2. THE CONTROL CONCEPT

ESRF-DCM design principle in three modes:

- Mode A: No control loop
- Mode B: Correction of repeatable errors

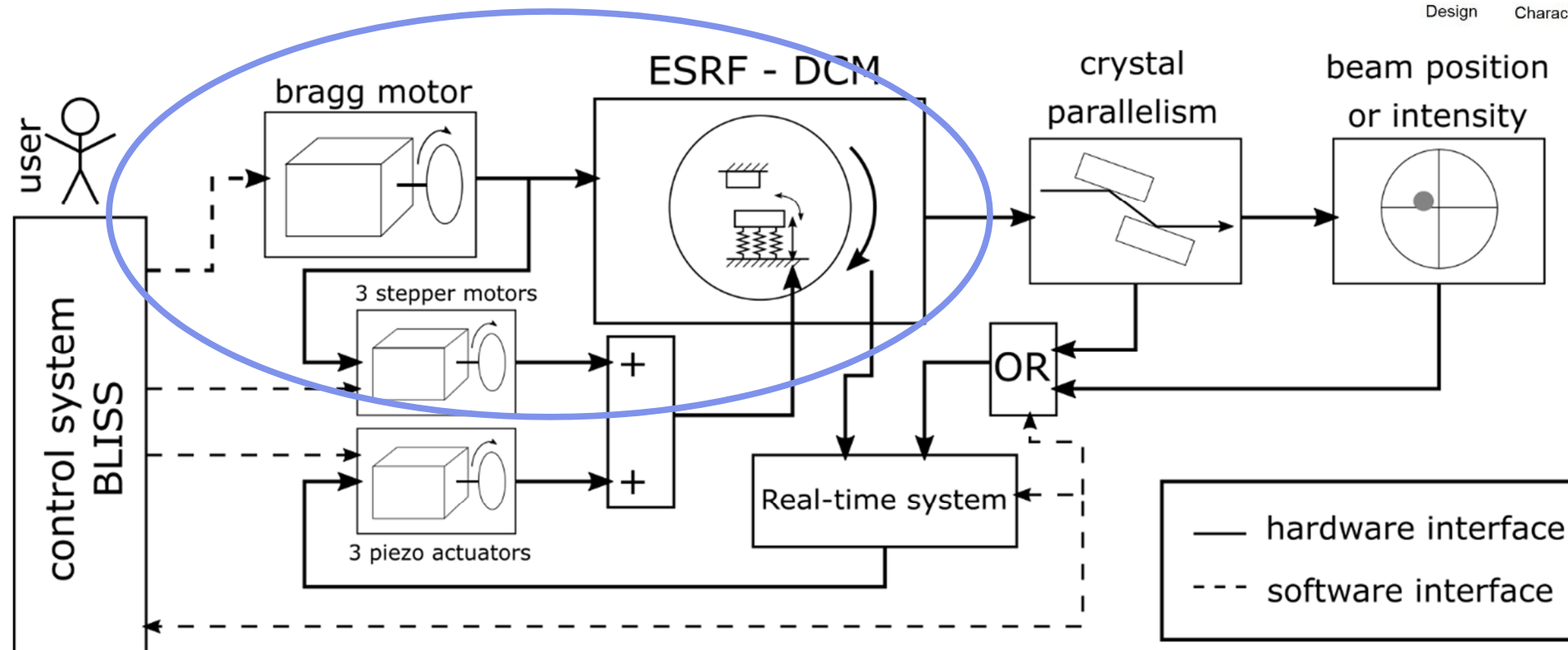
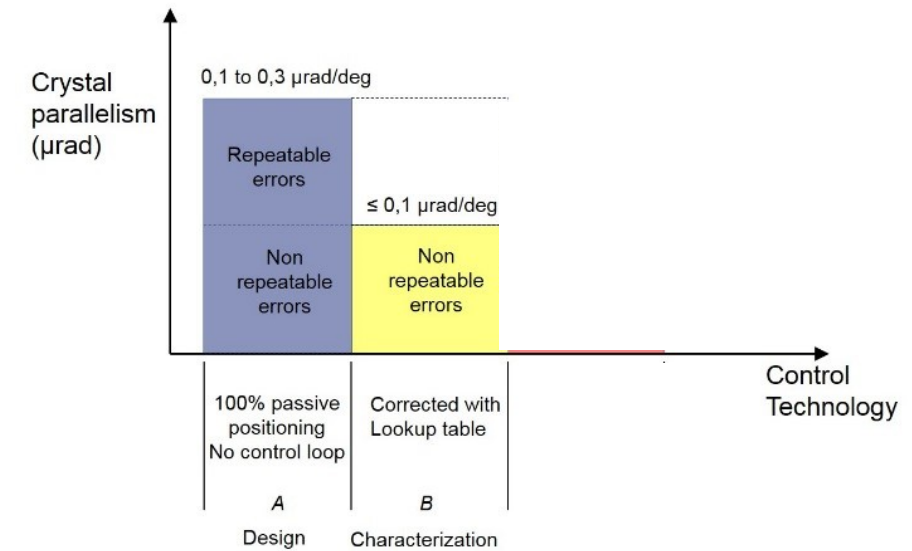

2. THE CONTROL CONCEPT

ESRF-DCM design principle in three modes:

- Mode A: No control loop
- Mode B: Correction of repeatable errors

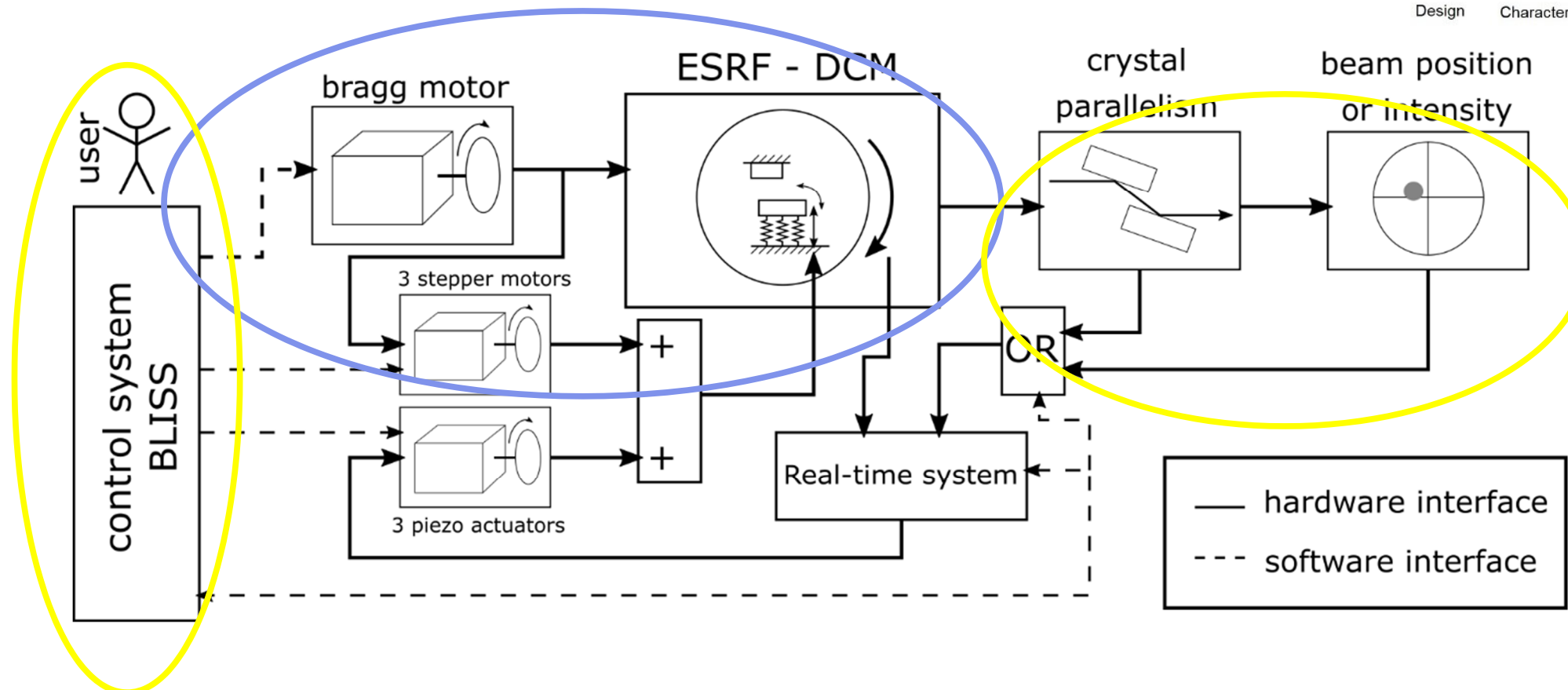
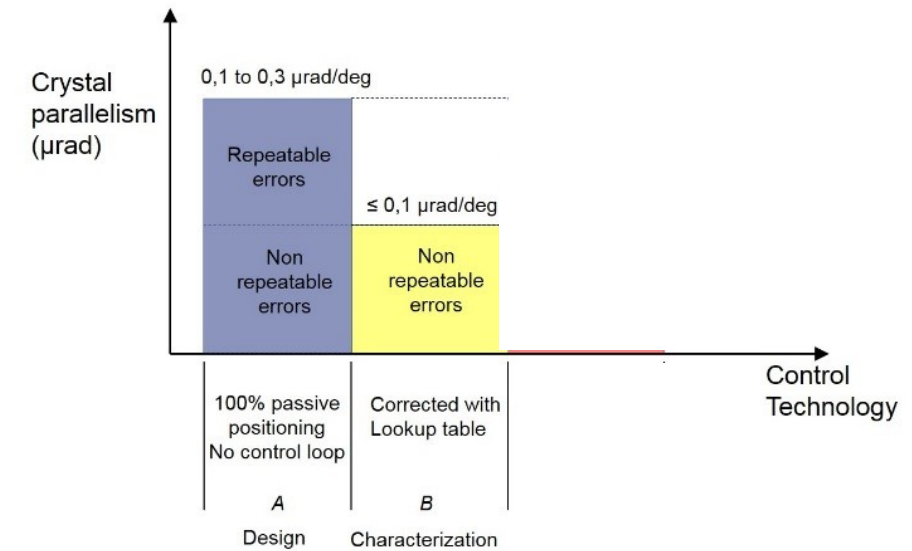

2. THE CONTROL CONCEPT

ESRF-DCM design principle in three modes:

- Mode A: No control loop
- Mode B: Correction of repeatable errors
- Mode C: Active real-time control

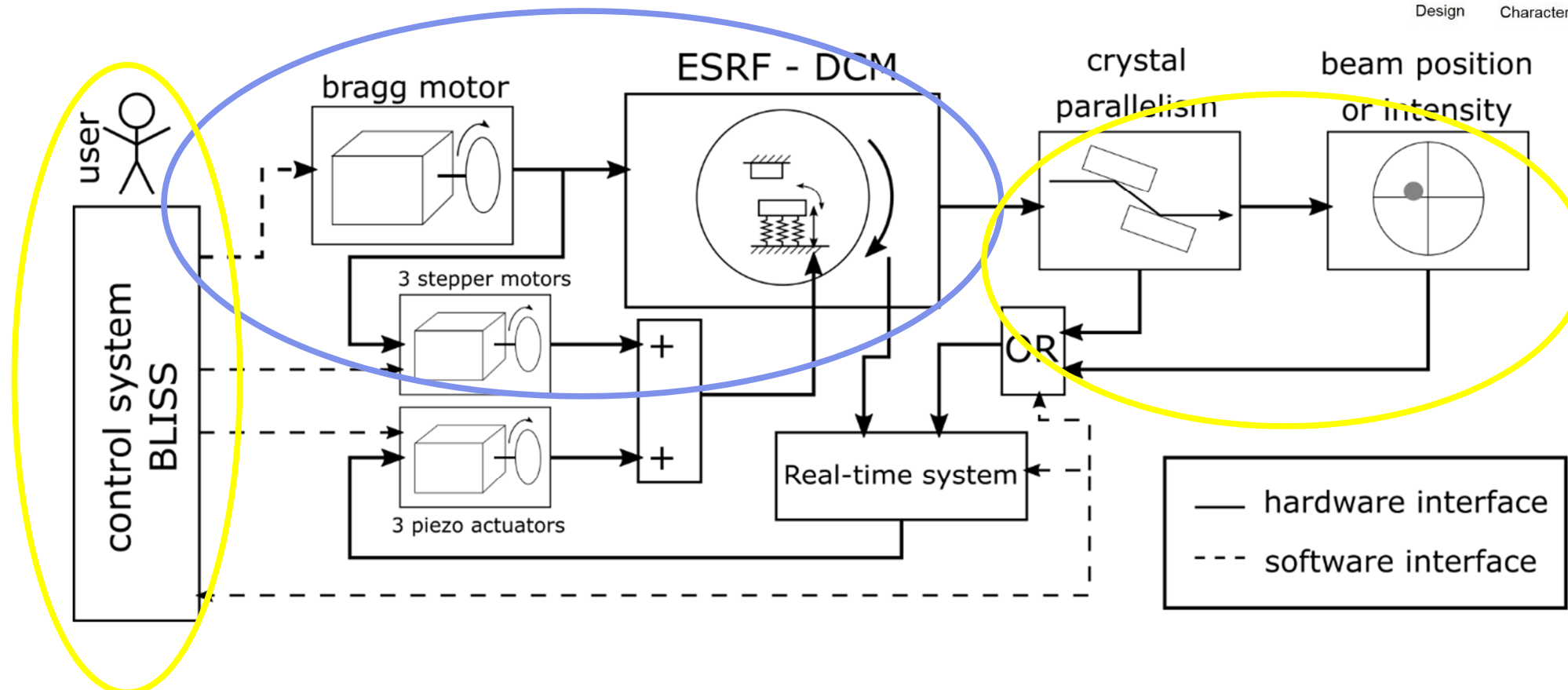
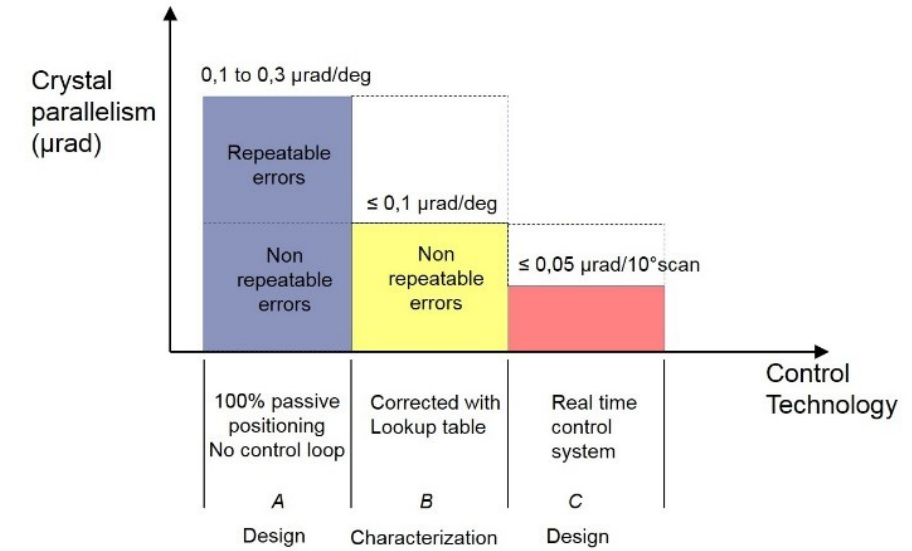

2. THE CONTROL CONCEPT

ESRF-DCM design principle in three modes:

- Mode A: No control loop
- Mode B: Correction of repeatable errors
- Mode C: Active real-time control

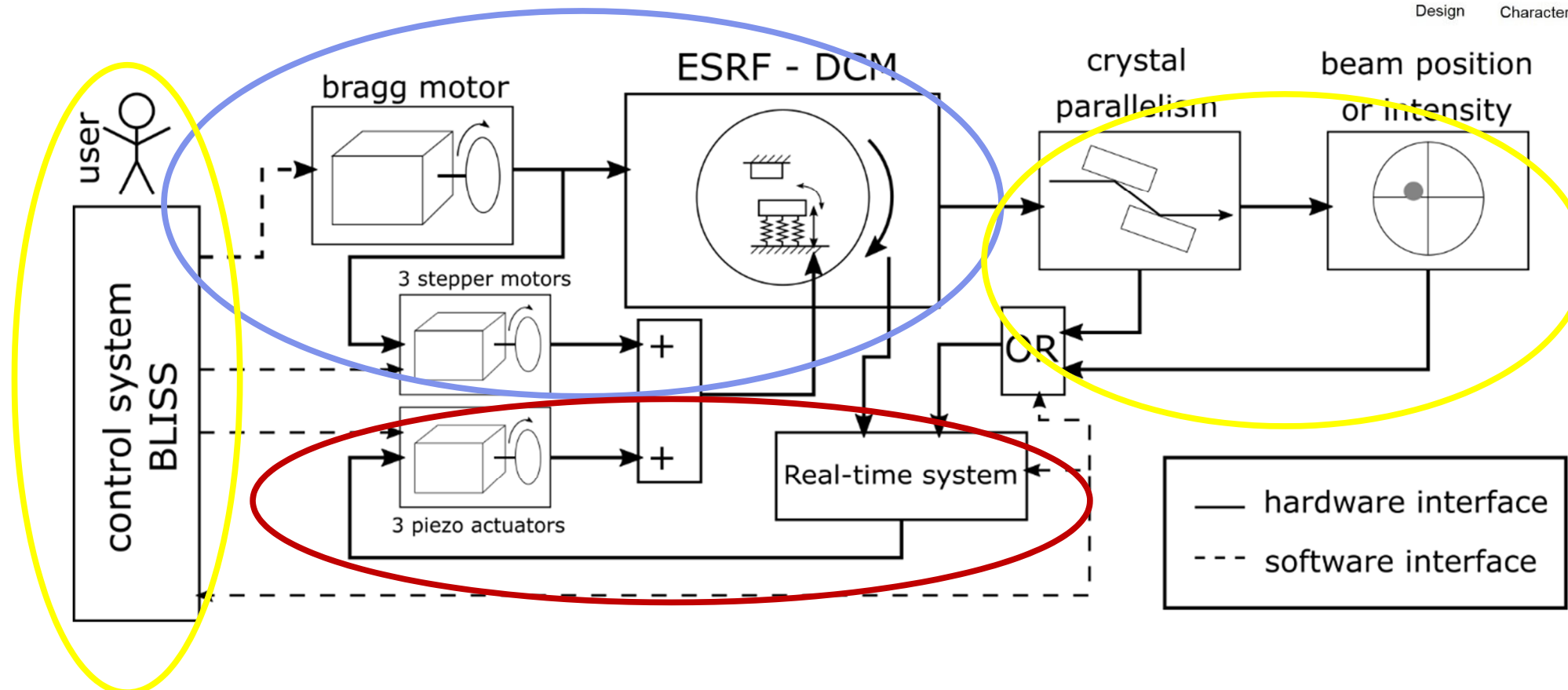
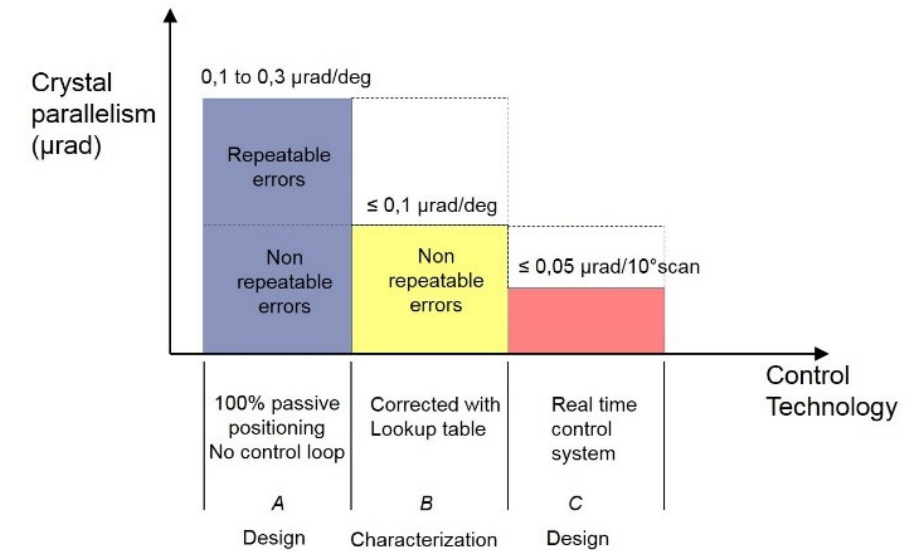

2. THE CONTROL CONCEPT

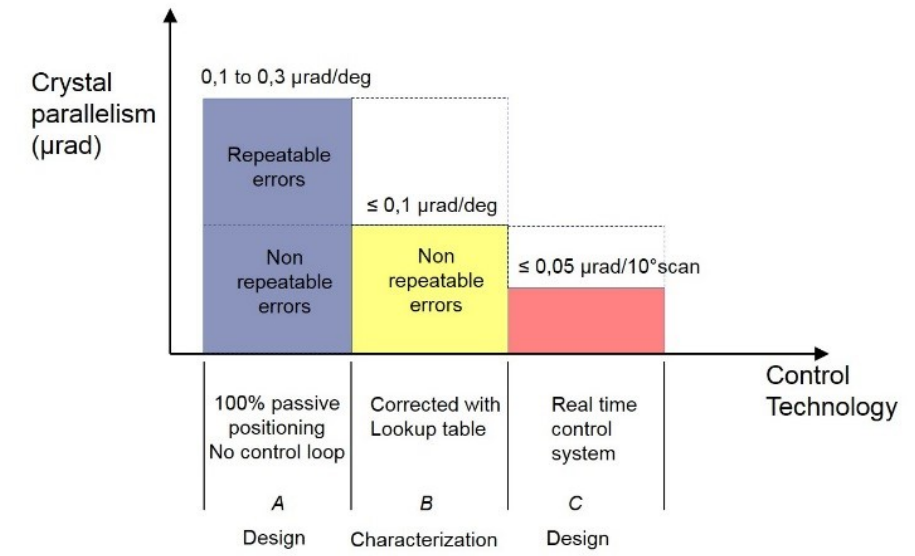

2. THE CONTROL CONCEPT

Resulting block diagram:

- Mode A:
- Mode B:
- Mode C:

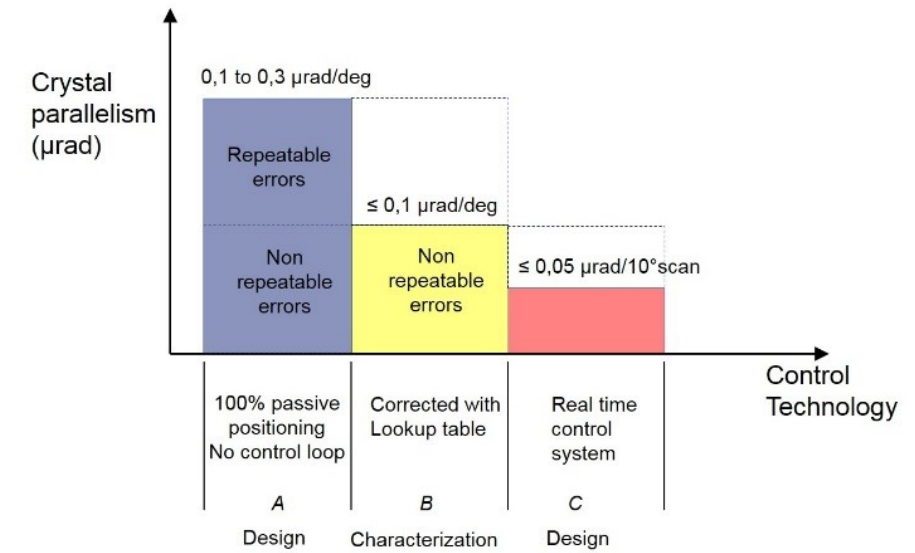

2. THE CONTROL CONCEPT

Resulting block diagram:

- Mode A:
$$Y(s) = \underbrace{G_P(s) G_{st}(s) H^{-1}}_{G_A(s)} R(s)$$
- Mode B:
- Mode C:

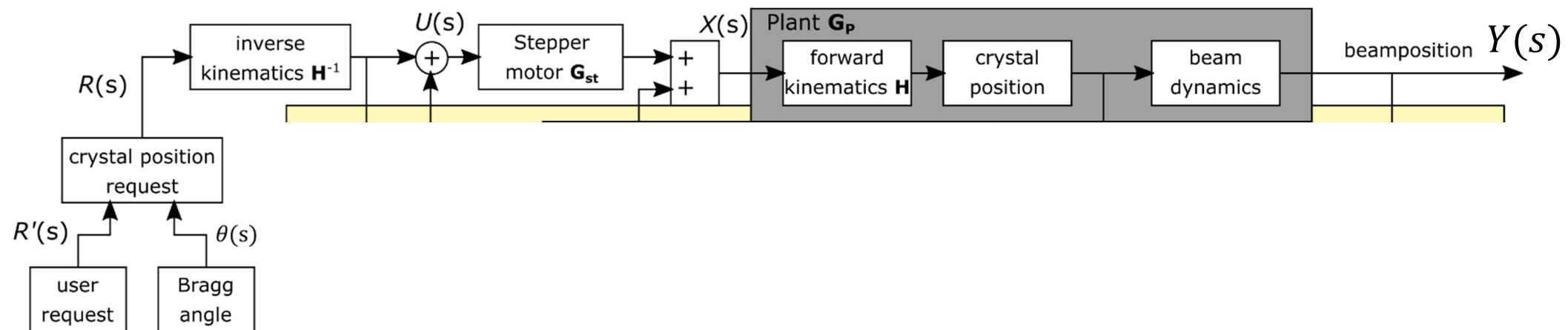
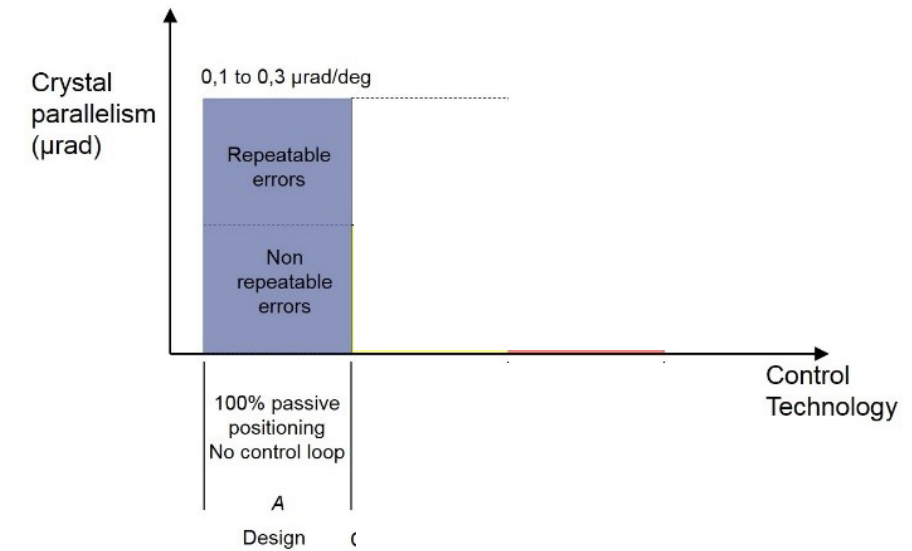

2. THE CONTROL CONCEPT

Resulting block diagram:

- Mode A:
$$Y(s) = \underbrace{G_P(s) G_{st}(s) H^{-1}}_{G_A(s)} R(s)$$

- Mode B:
$$\underline{u}_{j+1} = \underline{u}_j + L \underline{e}_j = \underline{u}_j + \beta \hat{G}_P^{-1} \underline{e}_j$$

- Mode C:

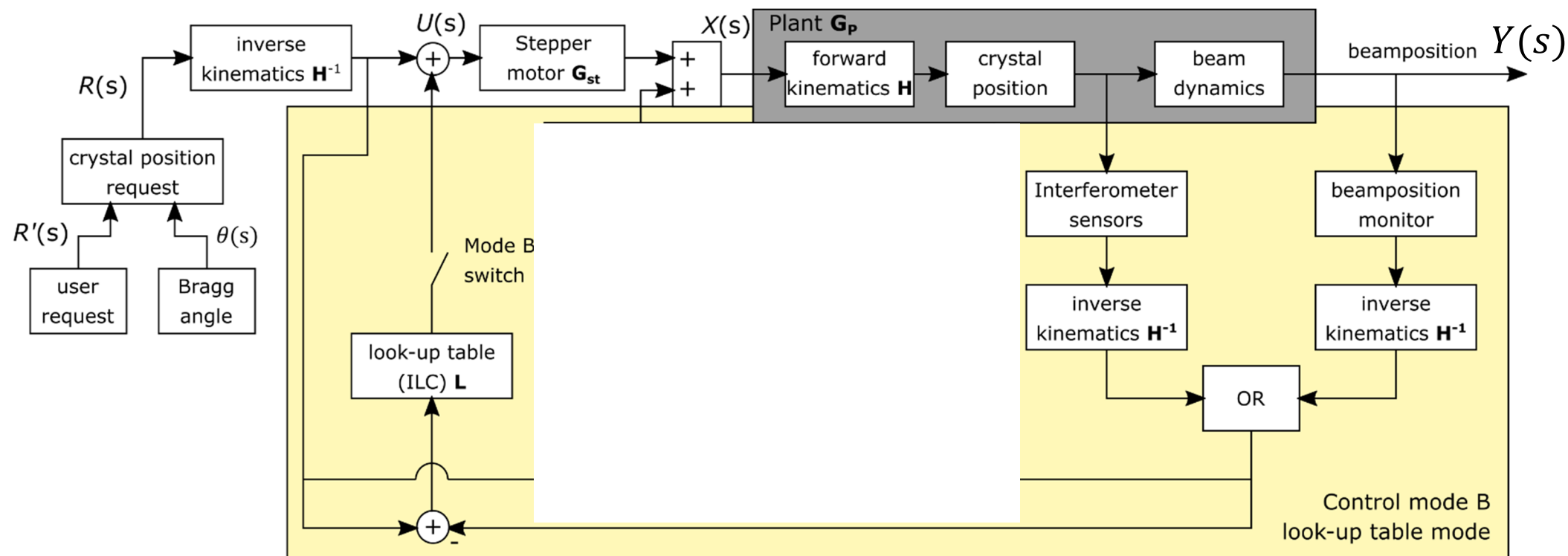
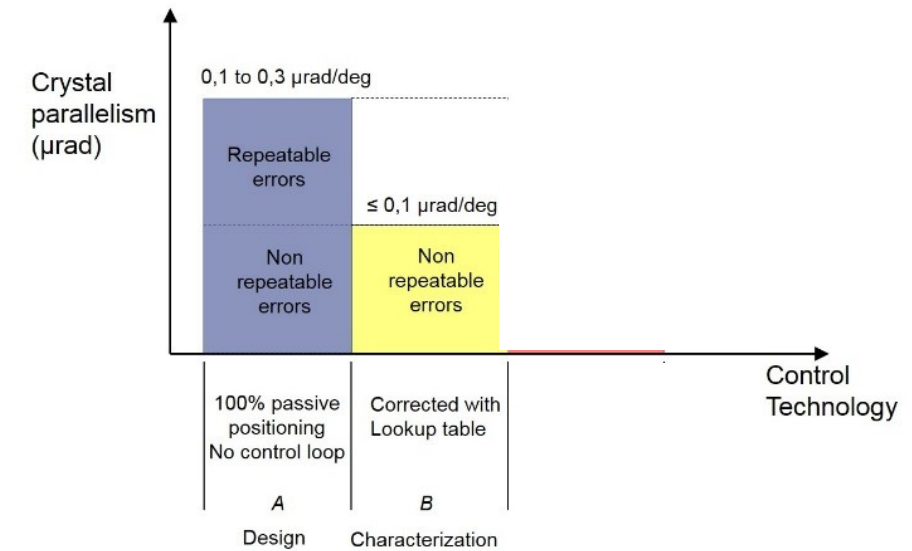

2. THE CONTROL CONCEPT

Resulting block diagram:

- Mode A:

$$Y(s) = \underbrace{G_P(s) G_{st}(s) H^{-1}}_{G_A(s)} R(s)$$

- Mode B:

$$\underline{u}_{j+1} = \underline{u}_j + L \underline{e}_j = \underline{u}_j + \beta \hat{G}_P^{-1} \underline{e}_j$$

- Mode C:

$$Y(s) = \underbrace{G_{PID} G_P (I_3 + G_{PID} G_P)^{-1} H^{-1}}_{G_C(s)} R(s)$$

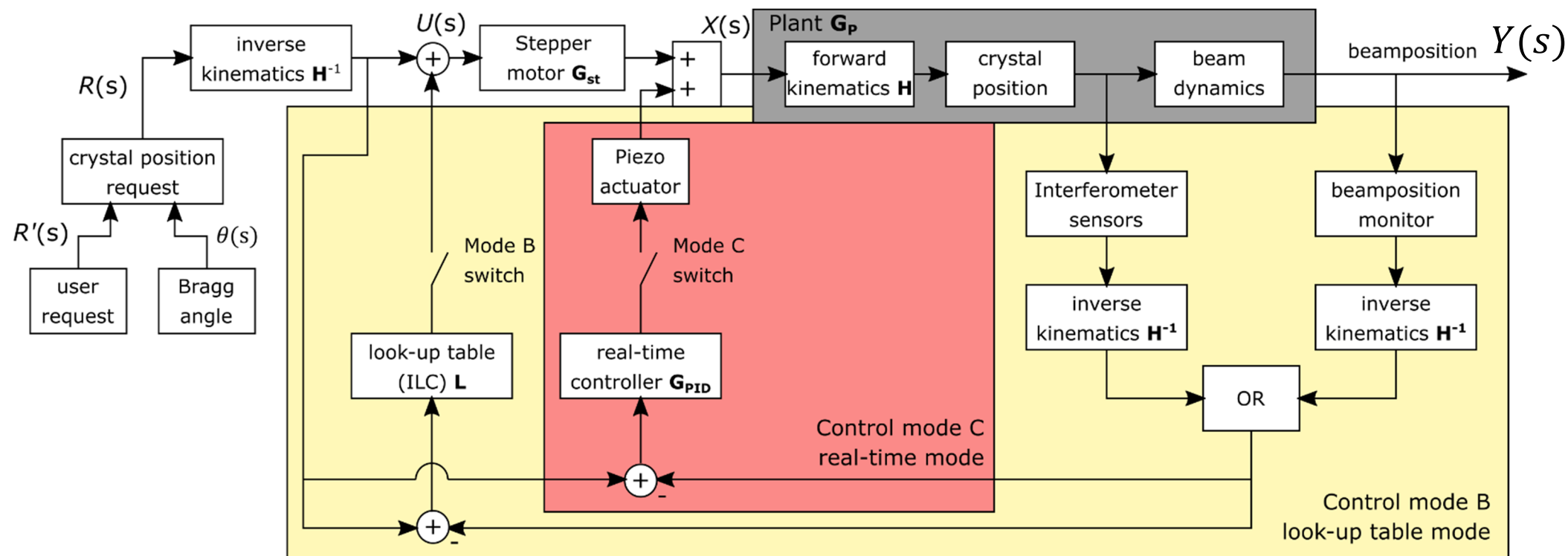
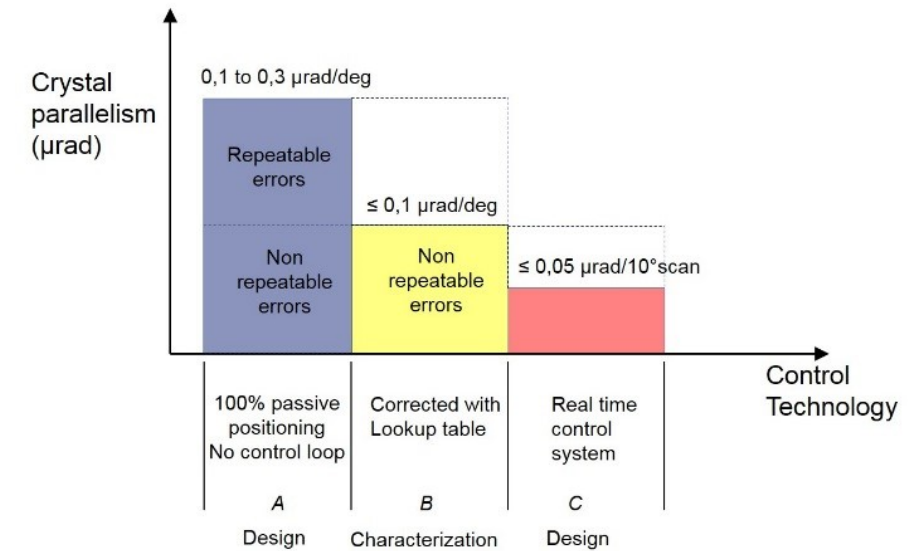

2. THE CONTROL CONCEPT

Integration into BLISS:

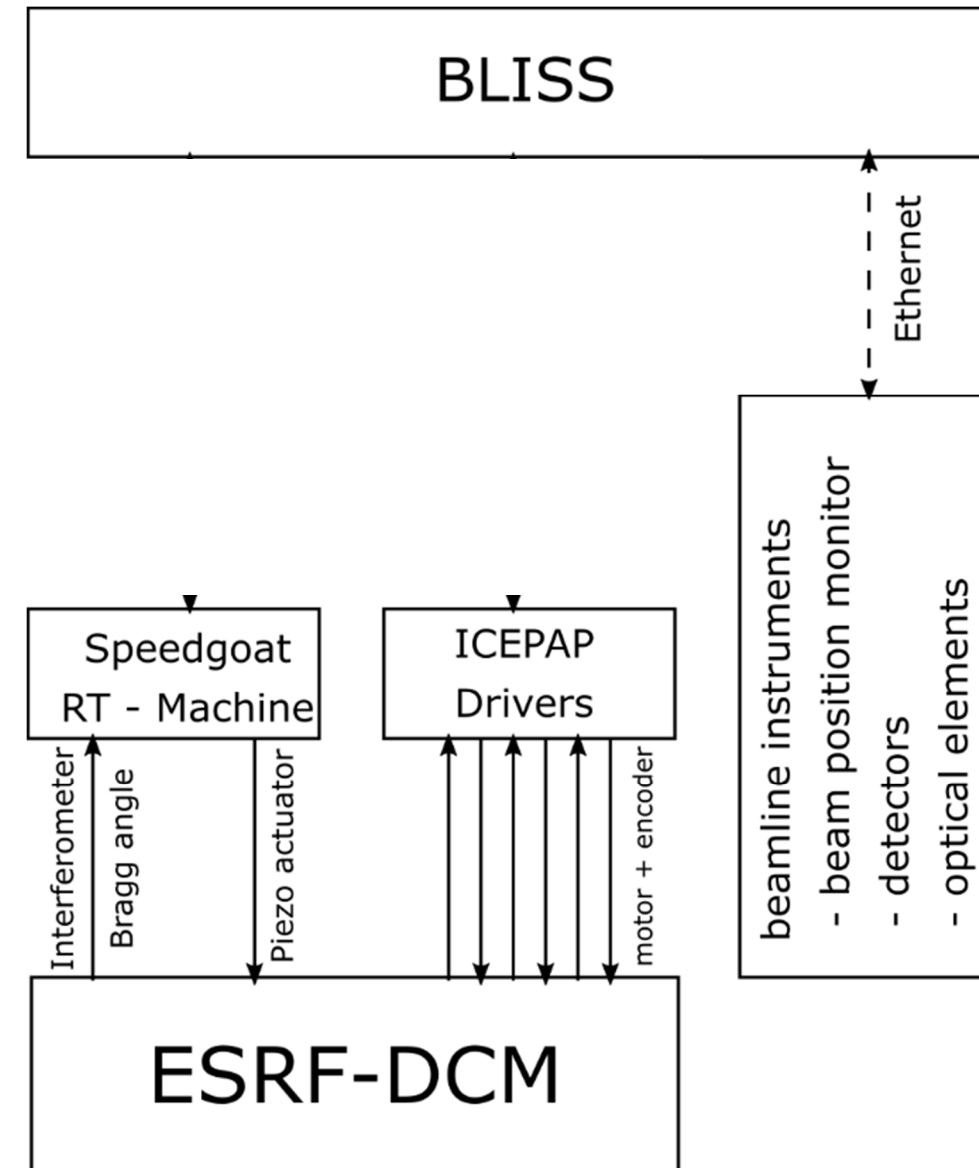

2. THE CONTROL CONCEPT

Integration into BLISS:

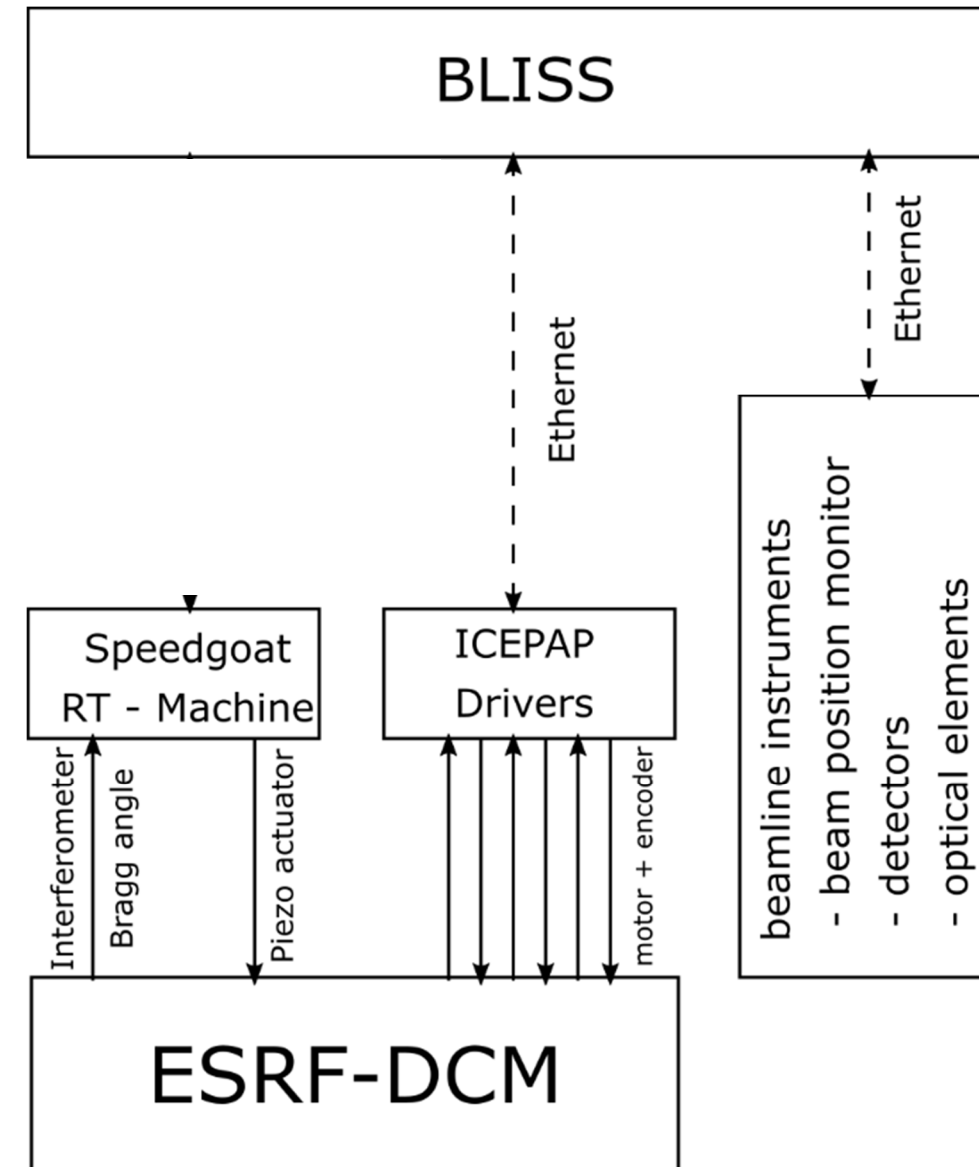

2. THE CONTROL CONCEPT

Integration into BLISS:

- Communication Speedgoat - BLISS:
 - BLISS RPC server and
 - Python wrapping of Speedgoat DLL

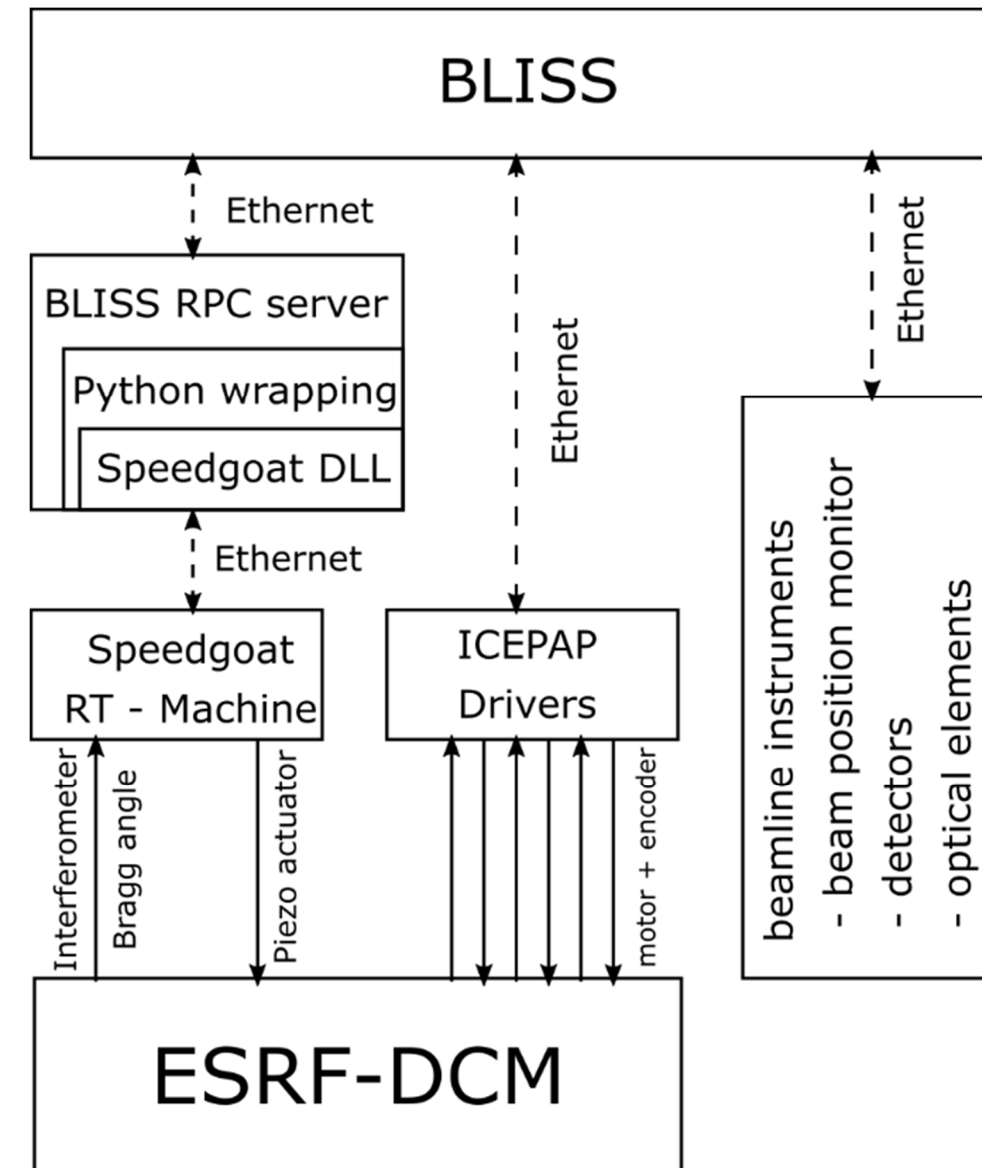

2. THE CONTROL CONCEPT

Integration into BLISS:

- Communication Speedgoat - BLISS:
 - BLISS RPC server and
 - Python wrapping of Speedgoat DLL
- Swapping of control modes:
 - swapping done via BLISS

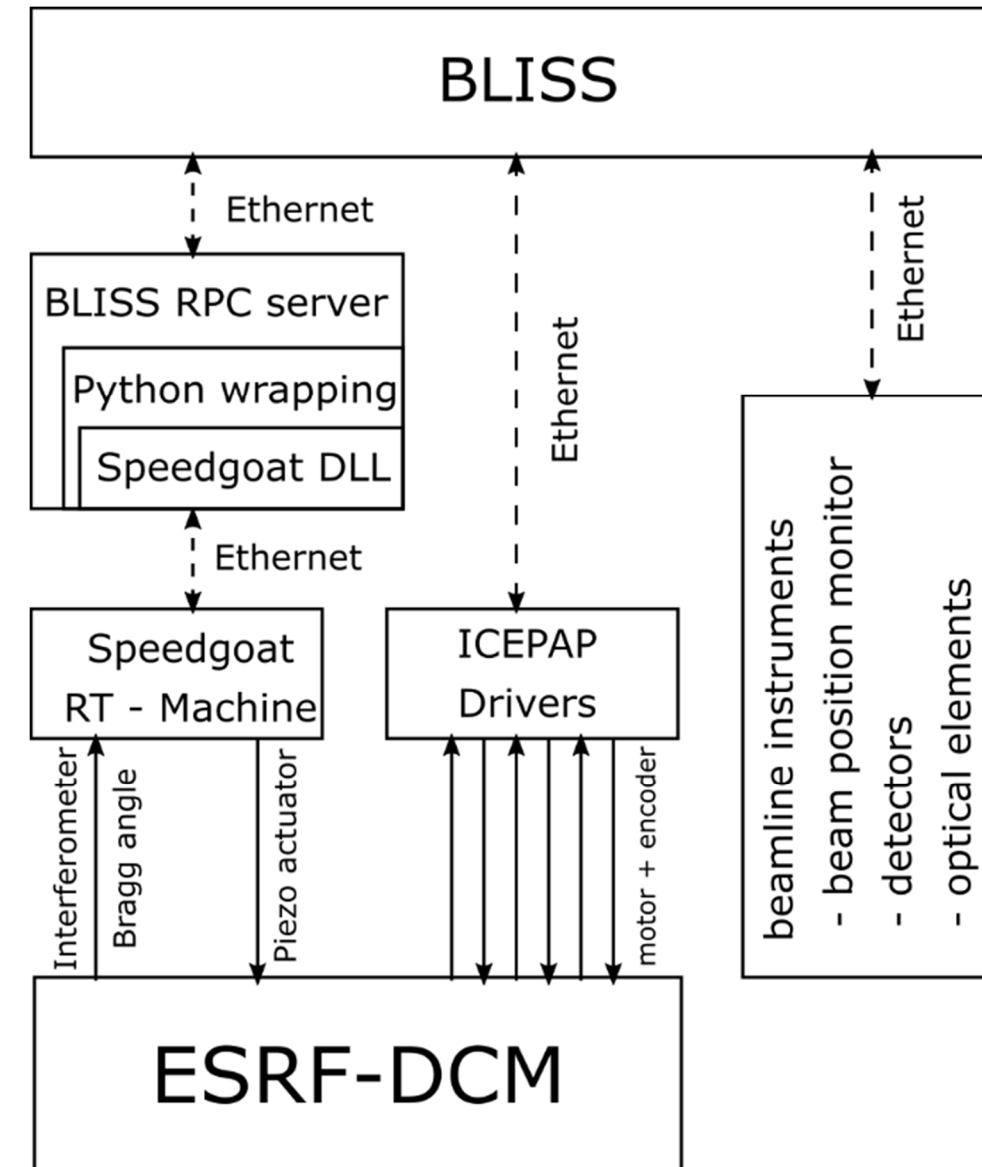

2. THE CONTROL CONCEPT

Integration into BLISS:

- Communication Speedgoat - BLISS:
 - BLISS RPC server and
 - Python wrapping of Speedgoat DLL
- Swapping of control modes:
 - swapping done via BLISS
 - Mode A and B → BLISS configures ICEPAP drivers

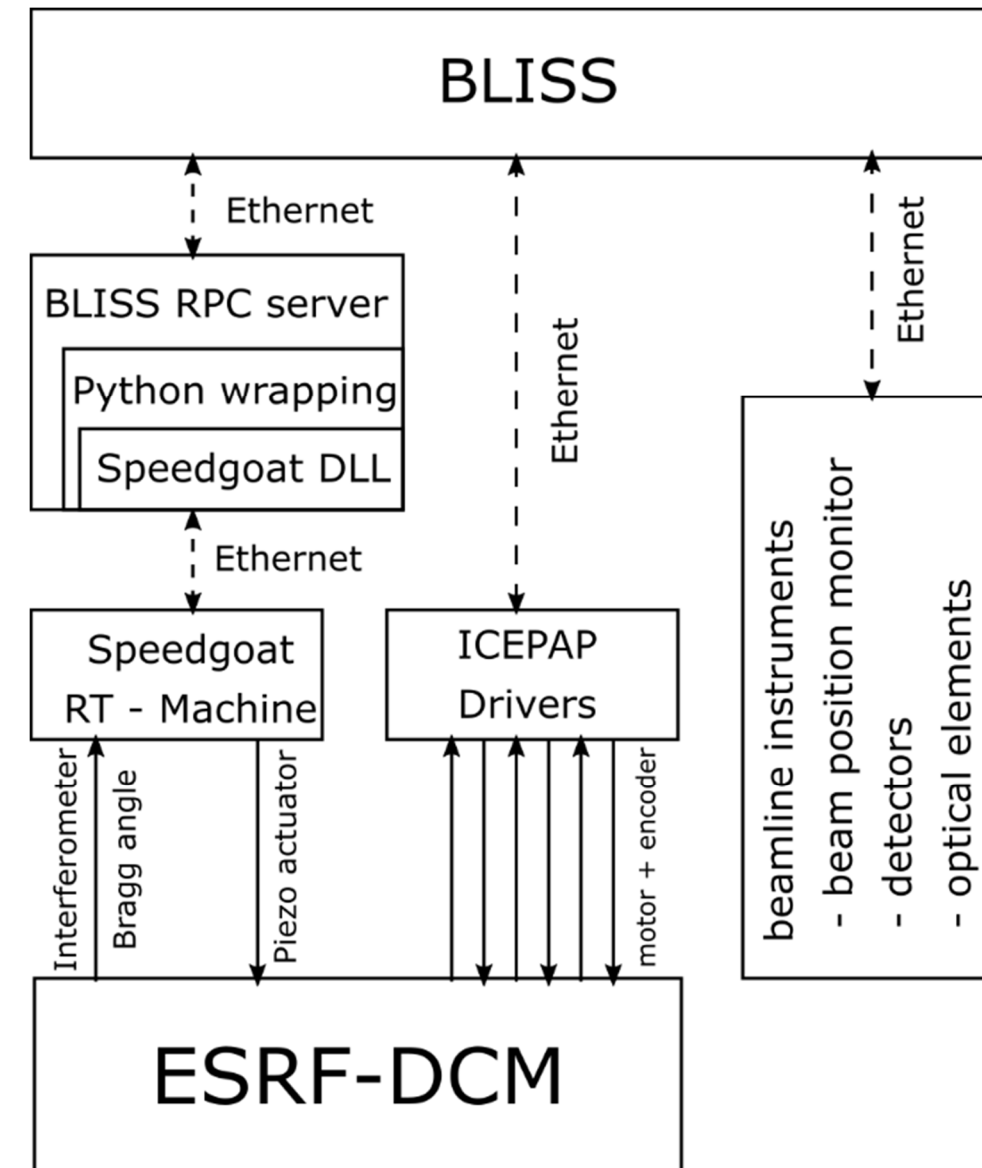

2. THE CONTROL CONCEPT

Integration into BLISS:

- Communication Speedgoat - BLISS:
 - BLISS RPC server and
 - Python wrapping of Speedgoat DLL
- Swapping of control modes:
 - swapping done via BLISS
 - Mode A and B → BLISS configures ICEPAP drivers

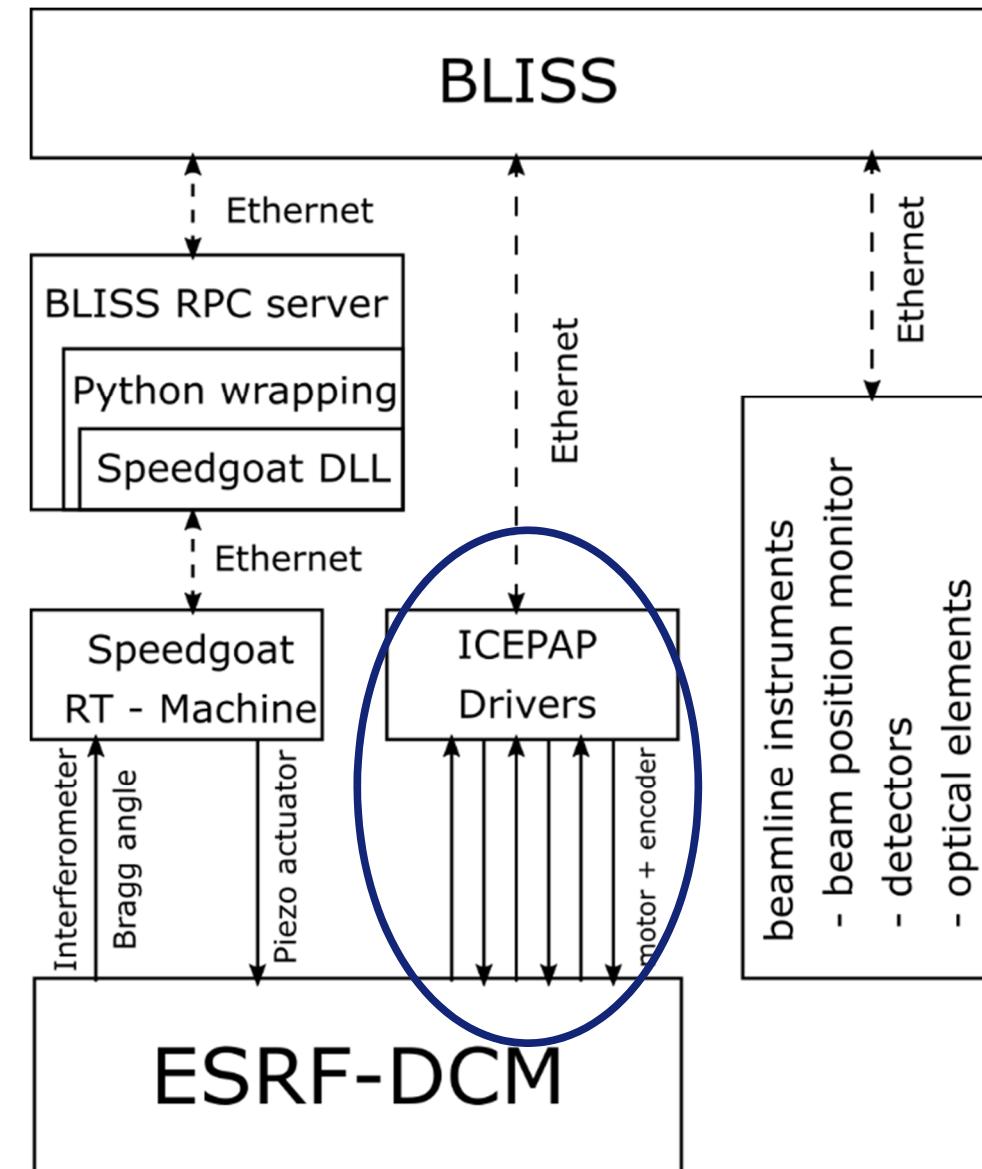

2. THE CONTROL CONCEPT

Integration into BLISS:

- Communication Speedgoat - BLISS:
 - BLISS RPC server and
 - Python wrapping of Speedgoat DLL
- Swapping of control modes:
 - swapping done via BLISS
 - Mode A and B → BLISS configures ICEPAP drivers

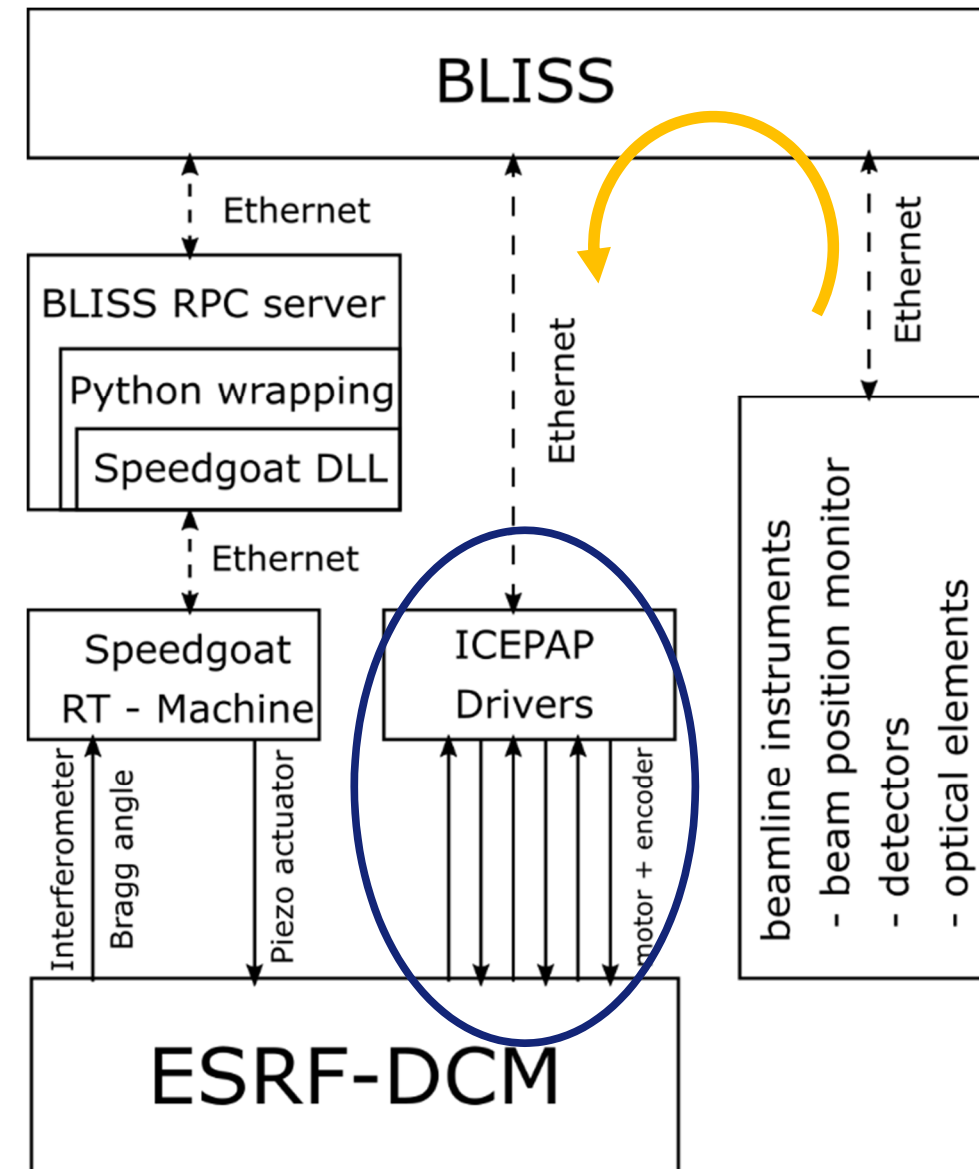

2. THE CONTROL CONCEPT

Integration into BLISS:

- Communication Speedgoat - BLISS:
 - BLISS RPC server and
 - Python wrapping of Speedgoat DLL
- Swapping of control modes:
 - swapping done via BLISS
 - Mode A and B → BLISS configures ICEPAP drivers

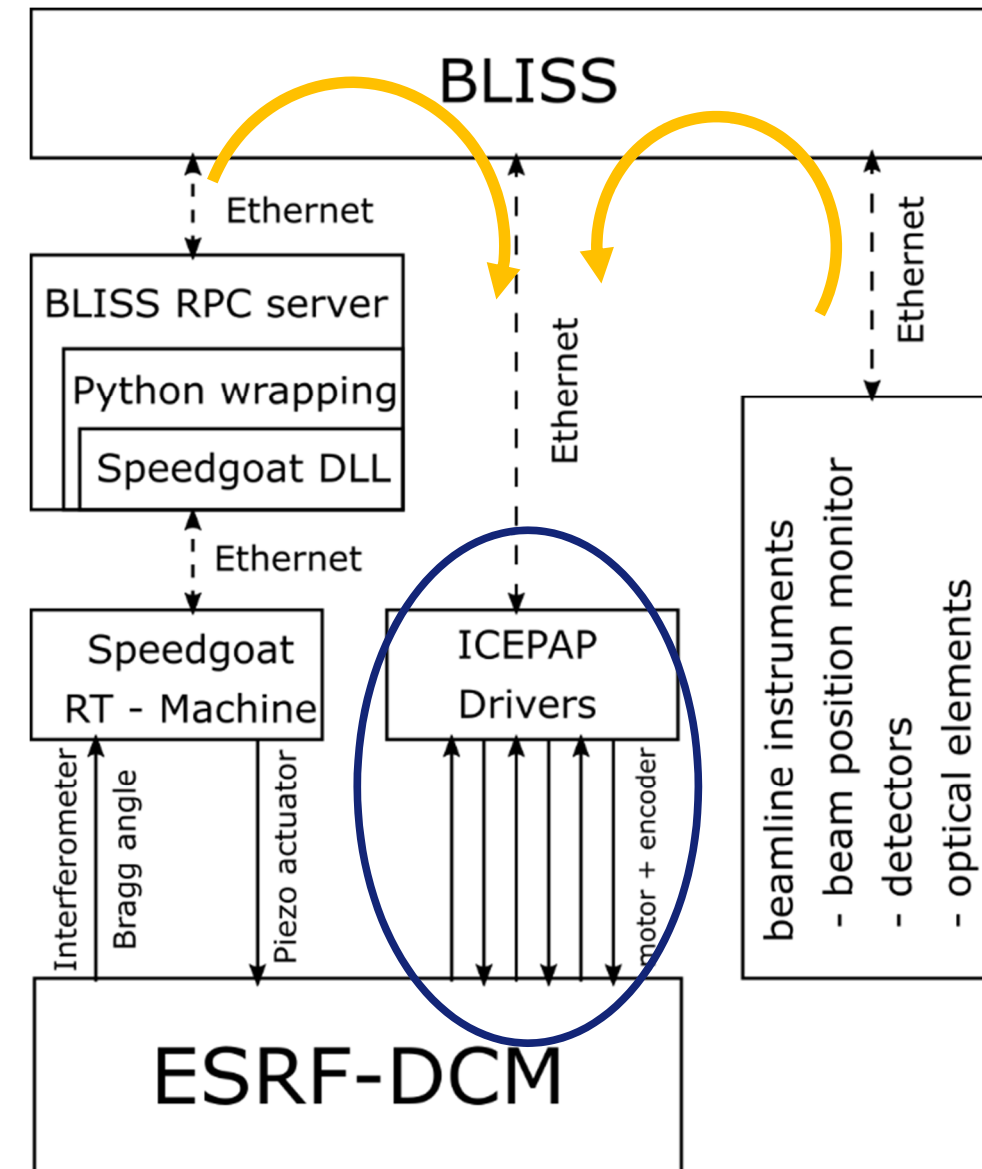

2. THE CONTROL CONCEPT

Integration into BLISS:

- Communication Speedgoat - BLISS:
 - BLISS RPC server and
 - Python wrapping of Speedgoat DLL
- Swapping of control modes:
 - swapping done via BLISS
 - Mode A and B → BLISS configures ICEPAP drivers
 - Mode C → BLISS closes the internal feedback loop on the RT – Machine

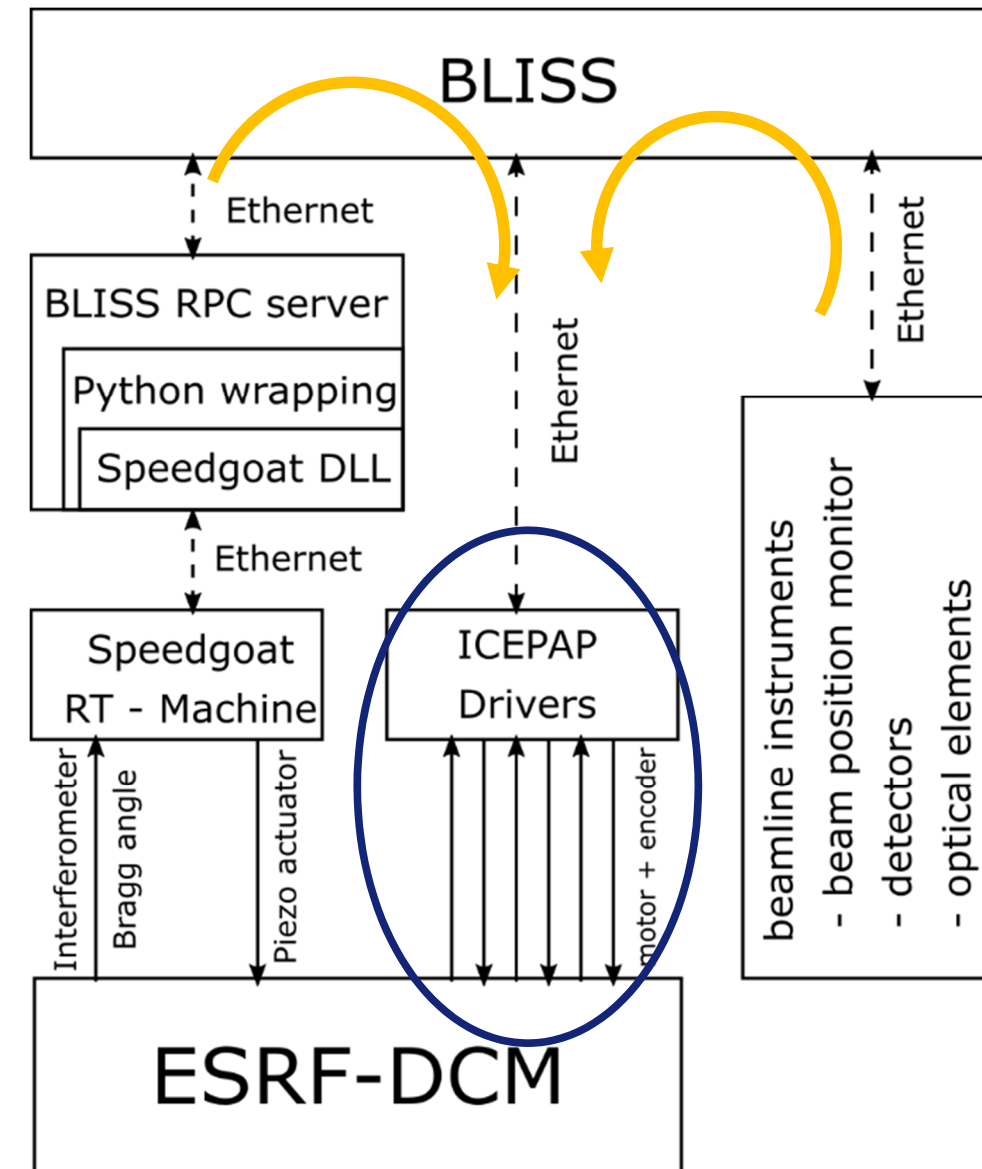

2. THE CONTROL CONCEPT

Integration into BLISS:

- Communication Speedgoat - BLISS:
 - BLISS RPC server and
 - Python wrapping of Speedgoat DLL
- Swapping of control modes:
 - swapping done via BLISS
 - Mode A and B → BLISS configures ICEPAP drivers
 - Mode C → BLISS closes the internal feedback loop on the RT – Machine

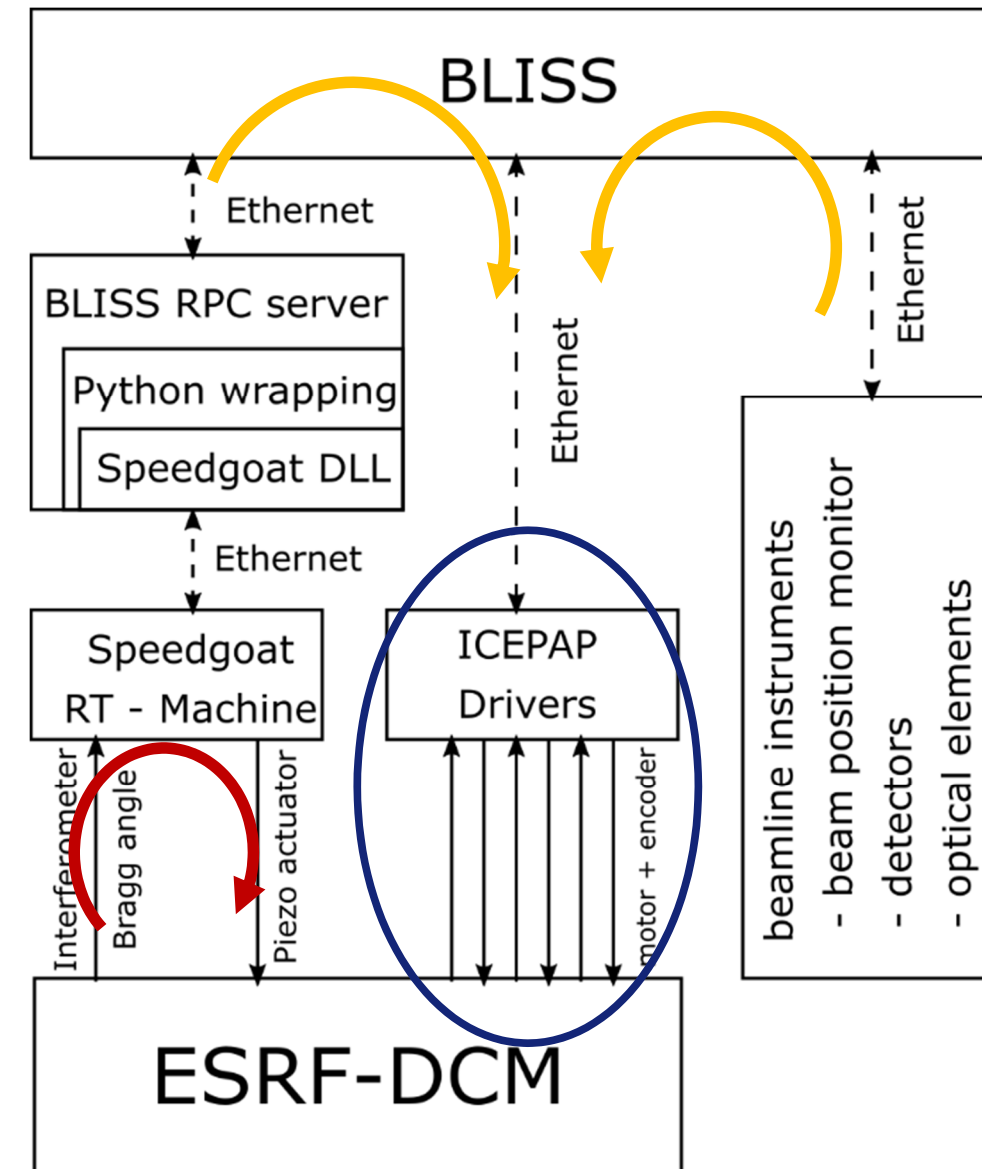

3. TEST SETUP AND RESULTS

Laser setup:

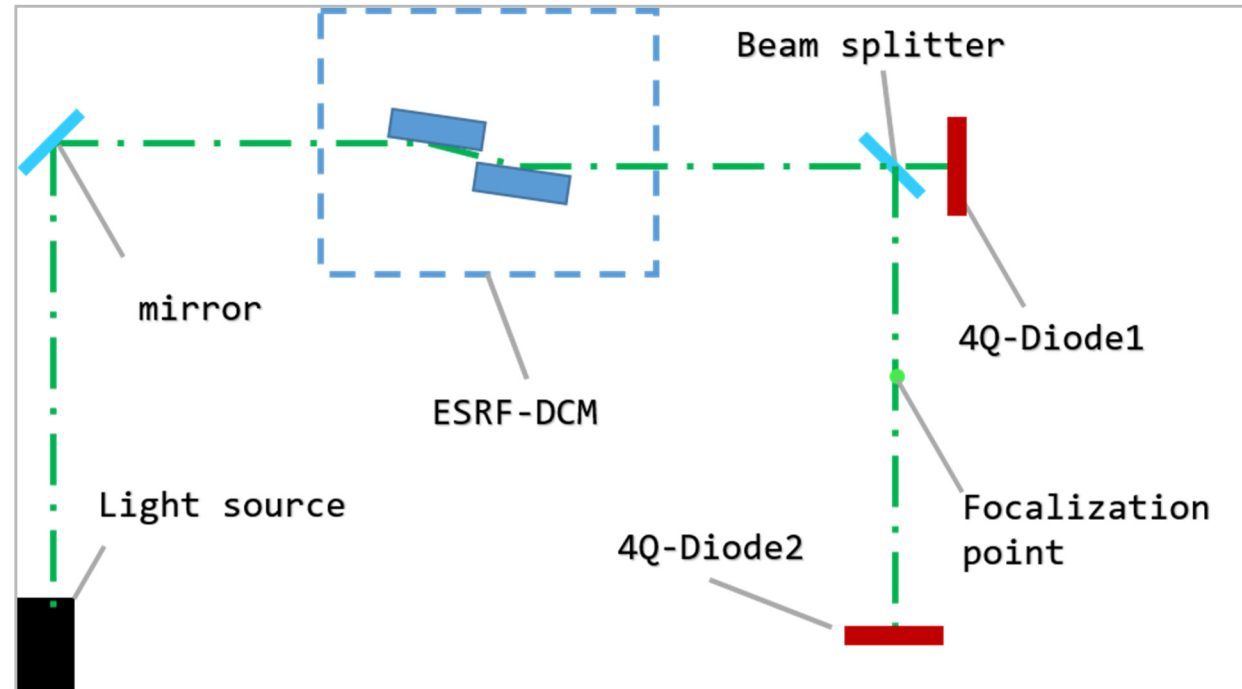

3. TEST SETUP AND RESULTS

Laser setup:

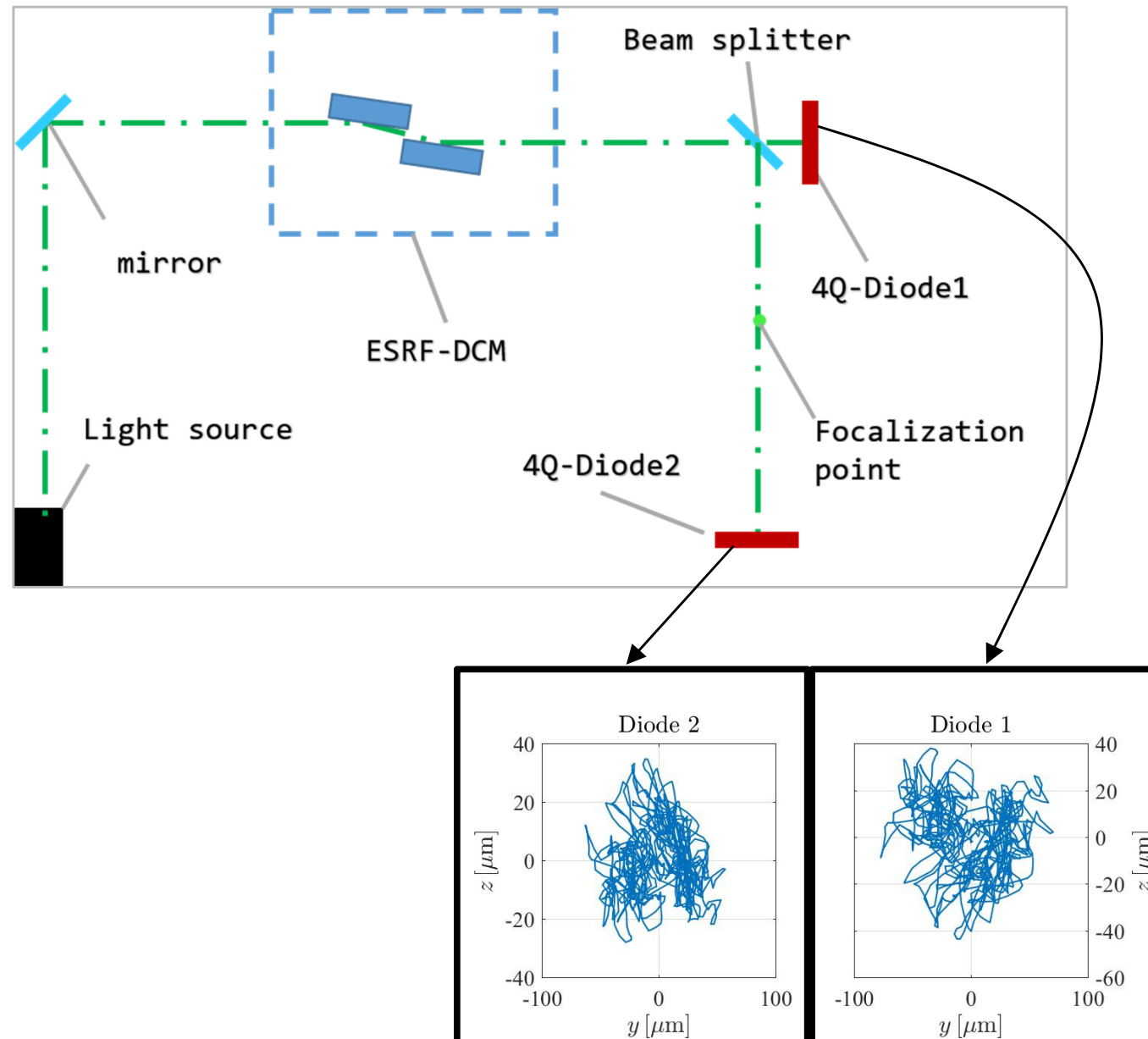

Beam stability at 10 degree scan:

- Mode A (blue)

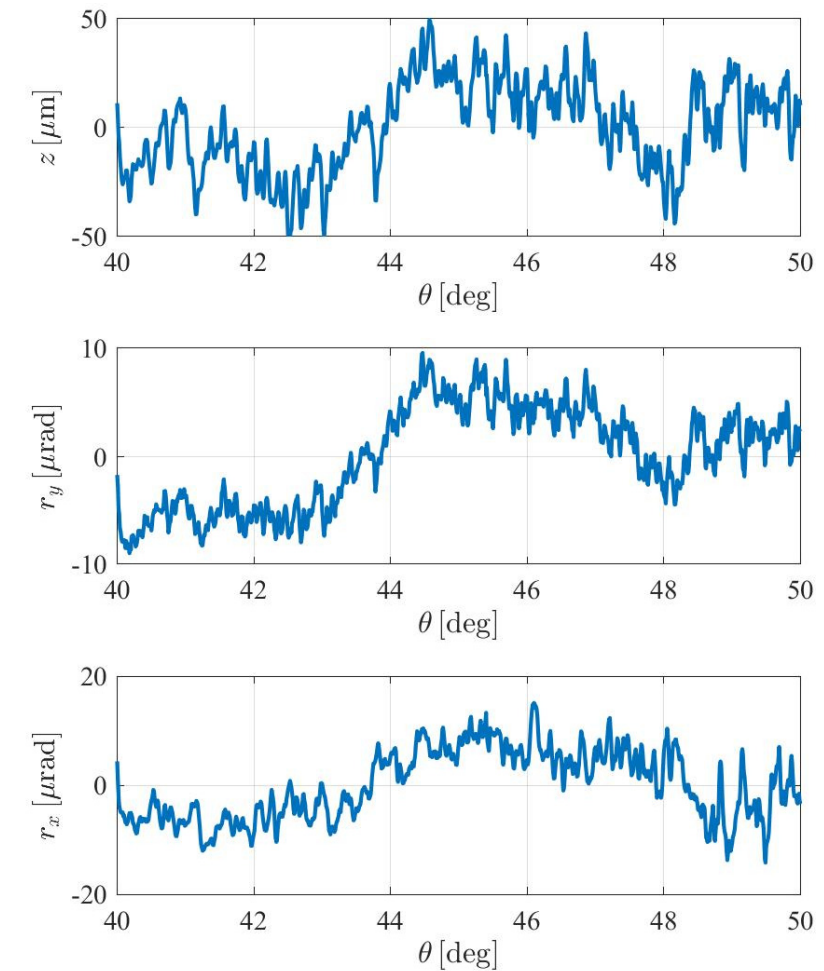

3. TEST SETUP AND RESULTS

Laser setup:

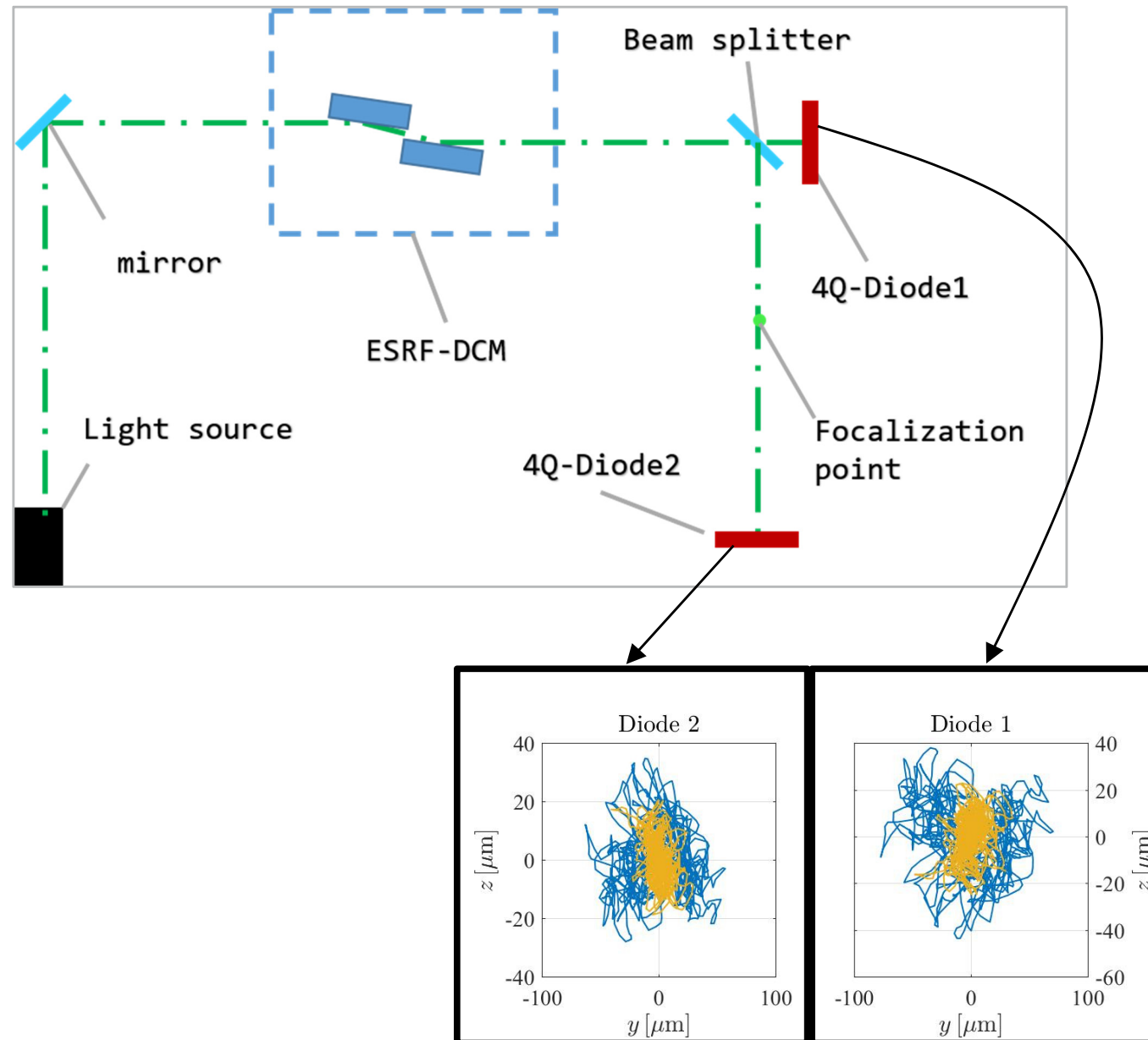

Beam stability at 10 degree scan:

- Mode A (blue)
- Mode B (yellow)

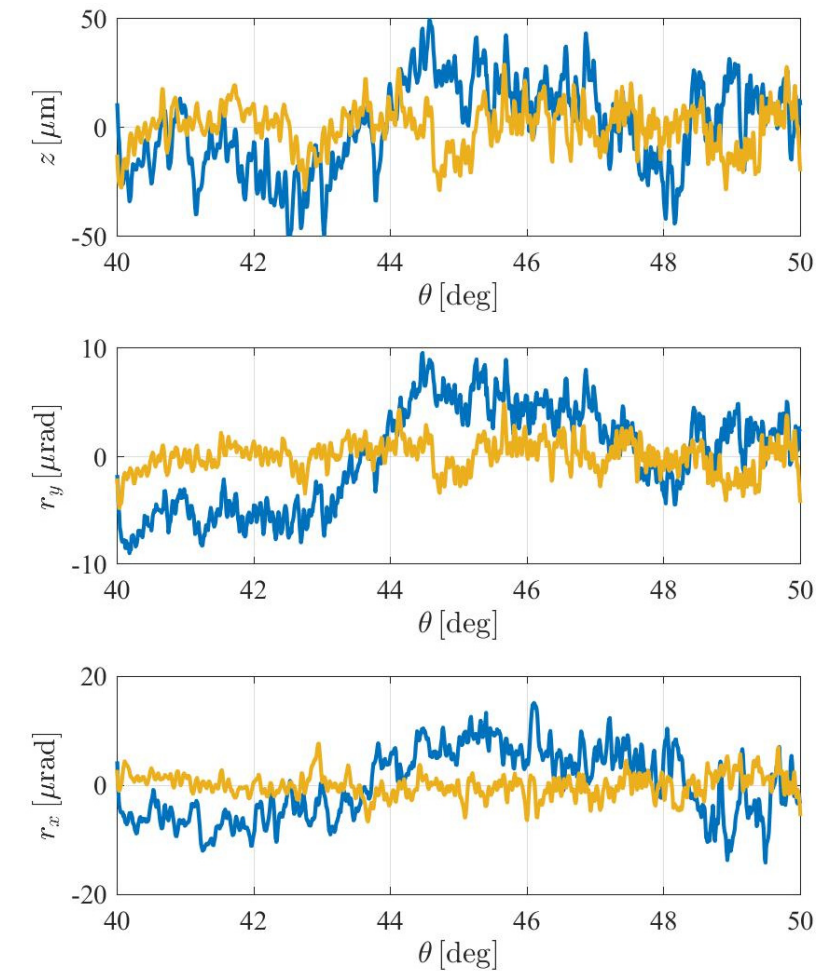

3. TEST SETUP AND RESULTS

Laser setup:

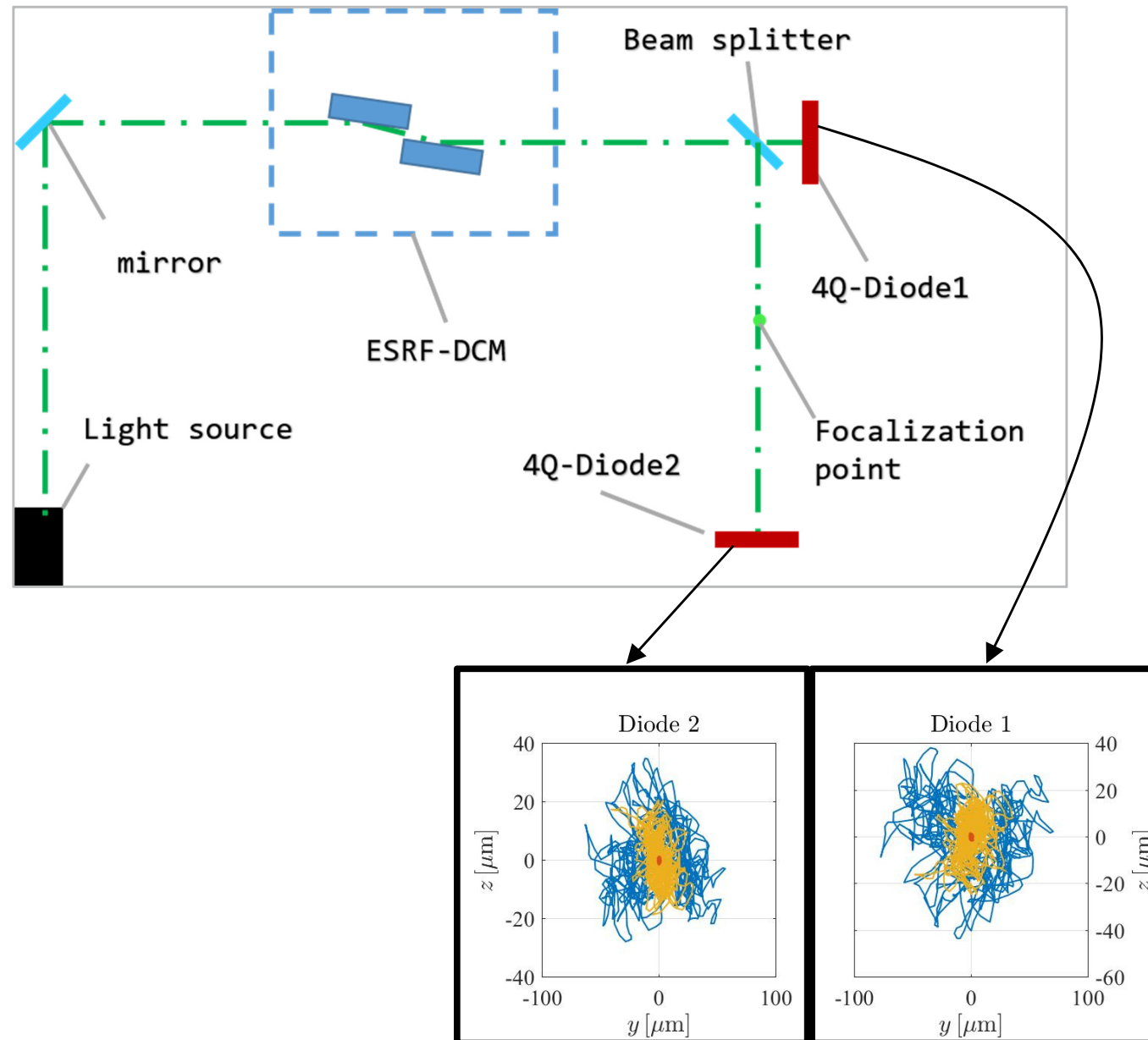

Beam stability at 10 degree scan:

- Mode A (blue)
- Mode B (yellow)
- Mode C (red)

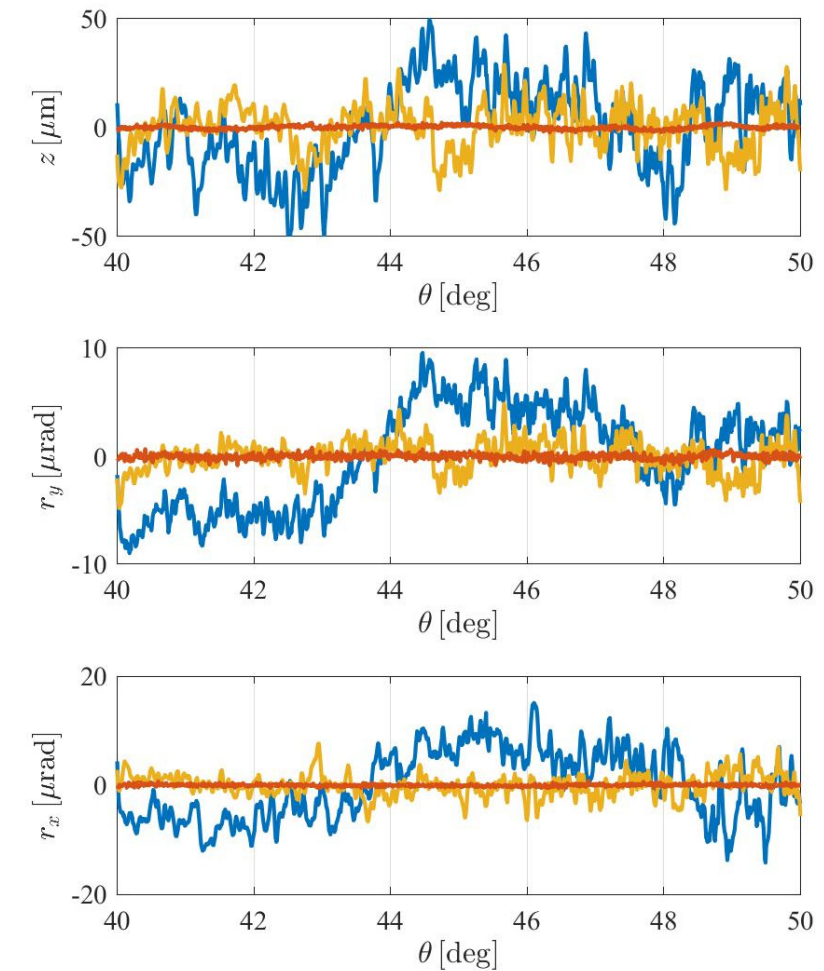

3. TEST SETUP AND RESULTS

Laser setup:

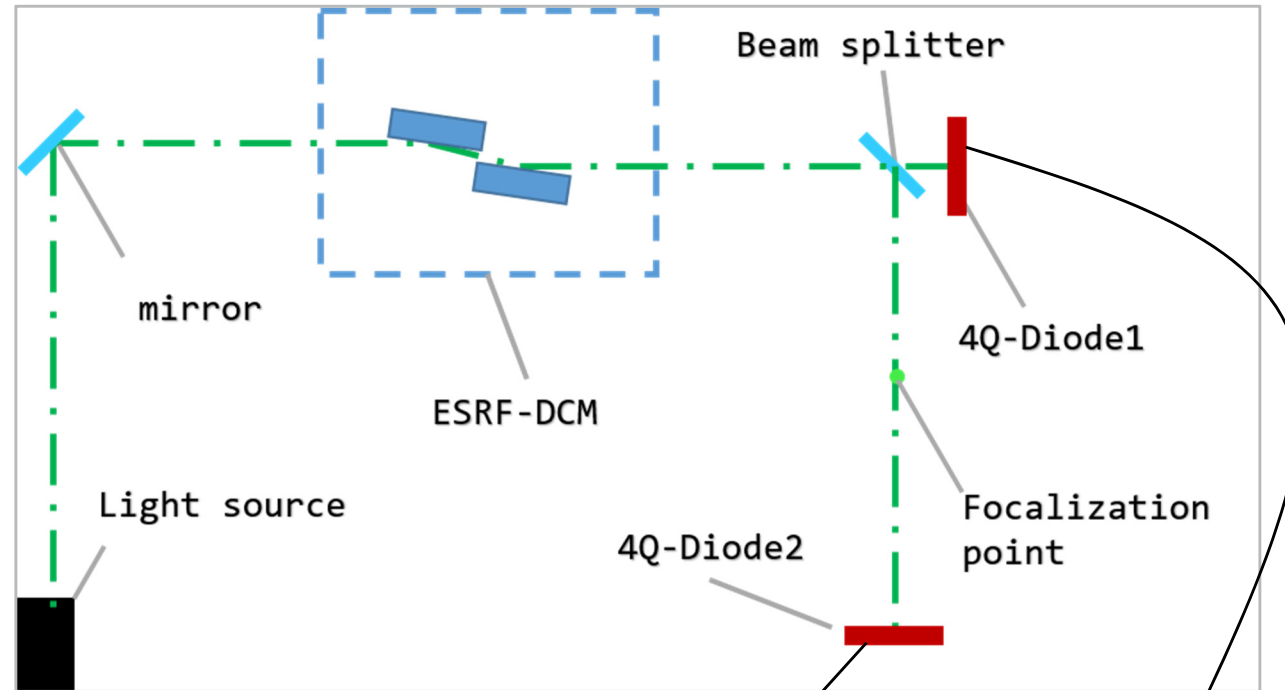

Beam stability on diodes:

- mode C scan (red)
- diode noise (purple)

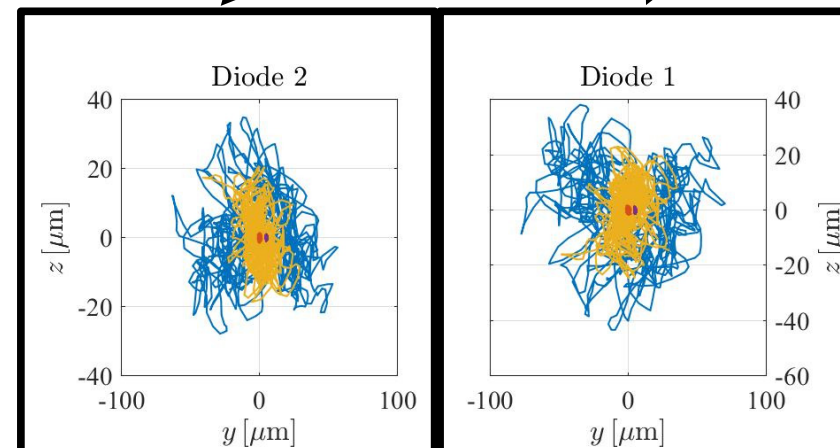

Beam stability at 10 degree scan:

- Mode A (blue)
- Mode B (yellow)
- Mode C (red)

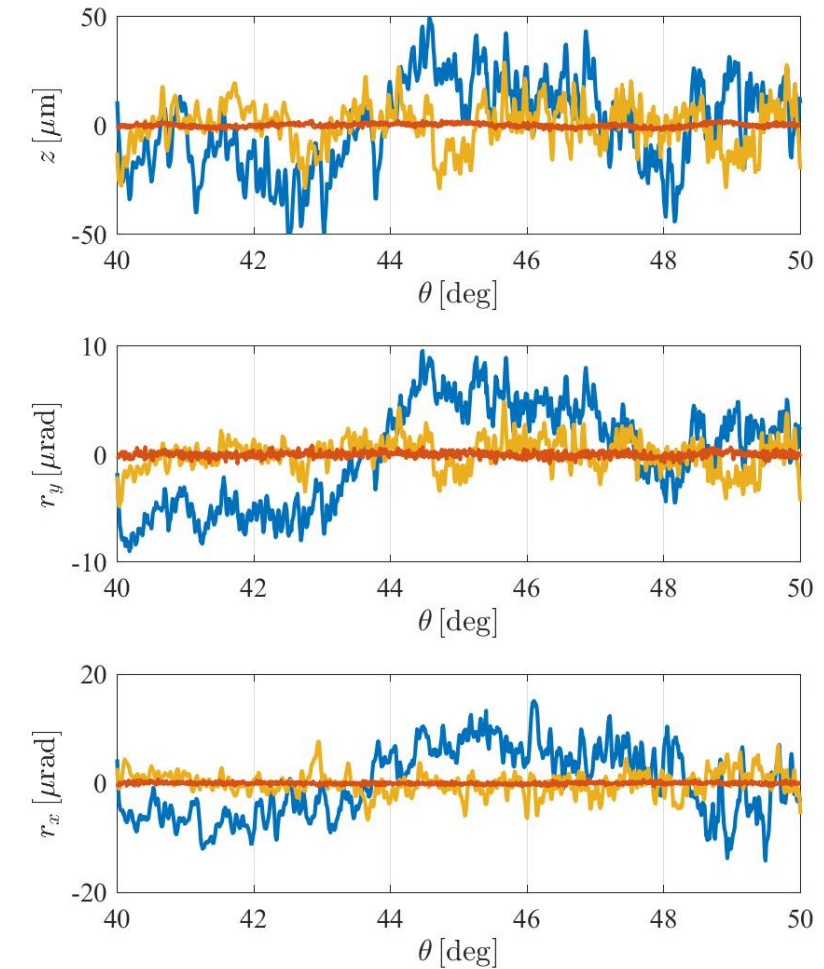

3. TEST SETUP AND RESULTS

Laser setup:

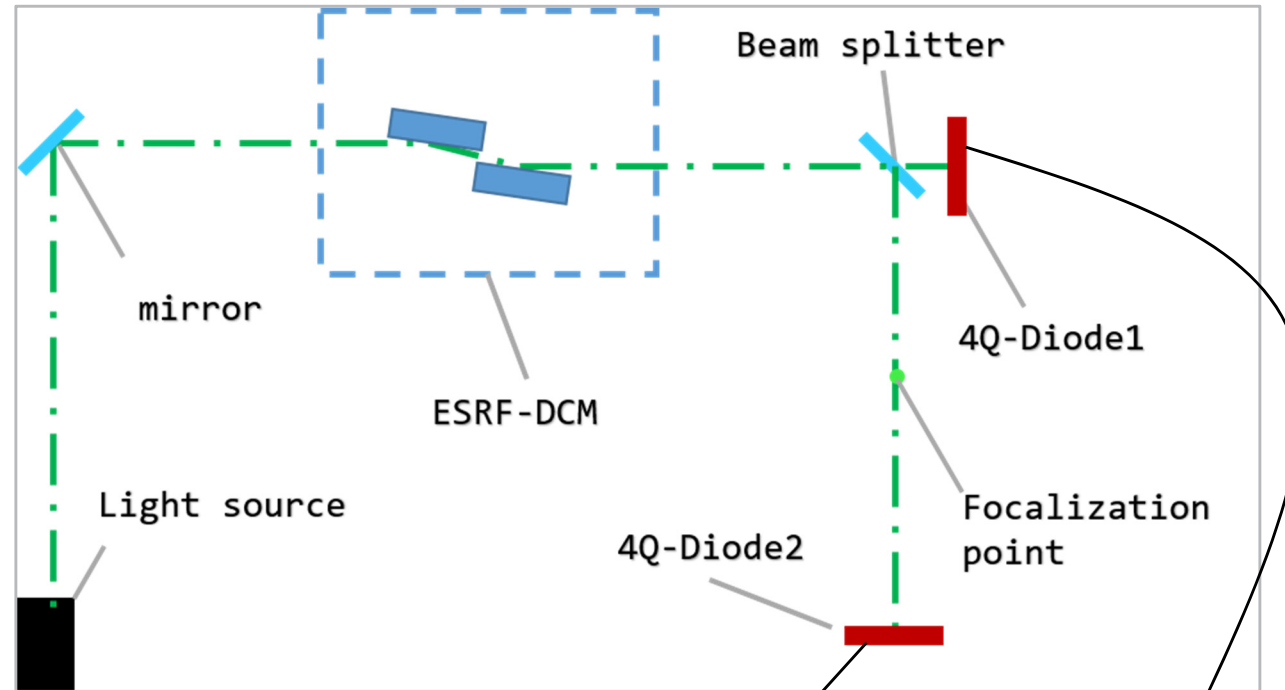

Beam stability on diodes:

- mode C scan (red)
- diode noise (purple)

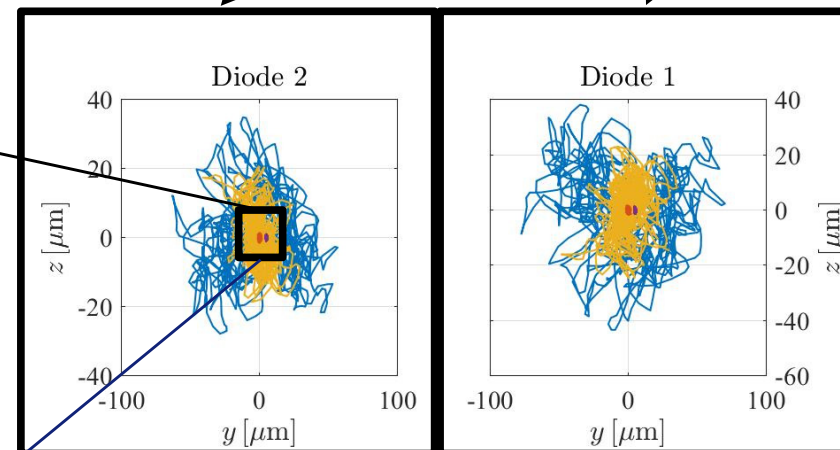
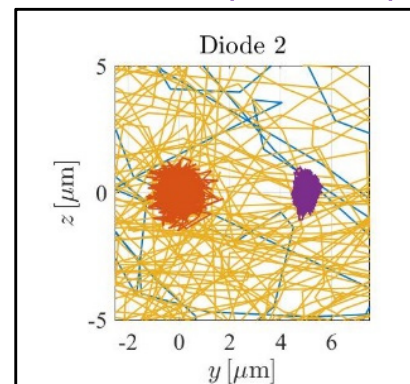

Beam stability at 10 degree scan:

- Mode A (blue)
- Mode B (yellow)
- Mode C (red)

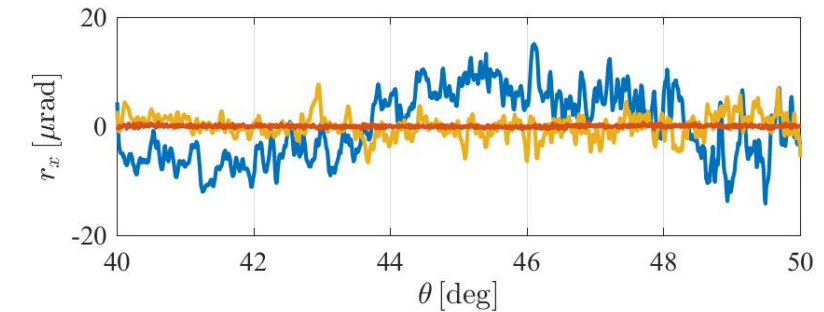
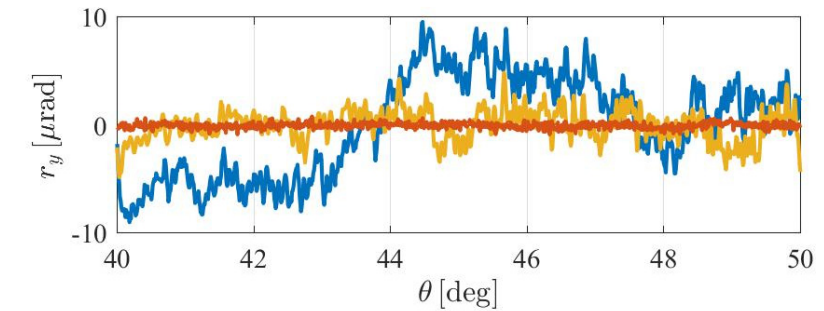
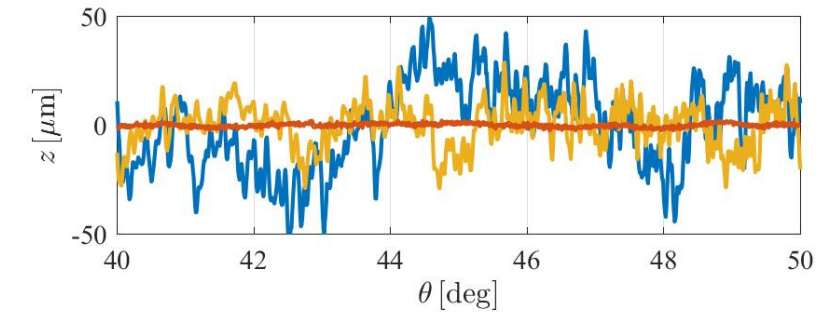

4. CONCLUSION

- **The control concept:**
 - follows the design principles
 - improves beam position stability by changing from mode A to B to C
 - works in degraded modes

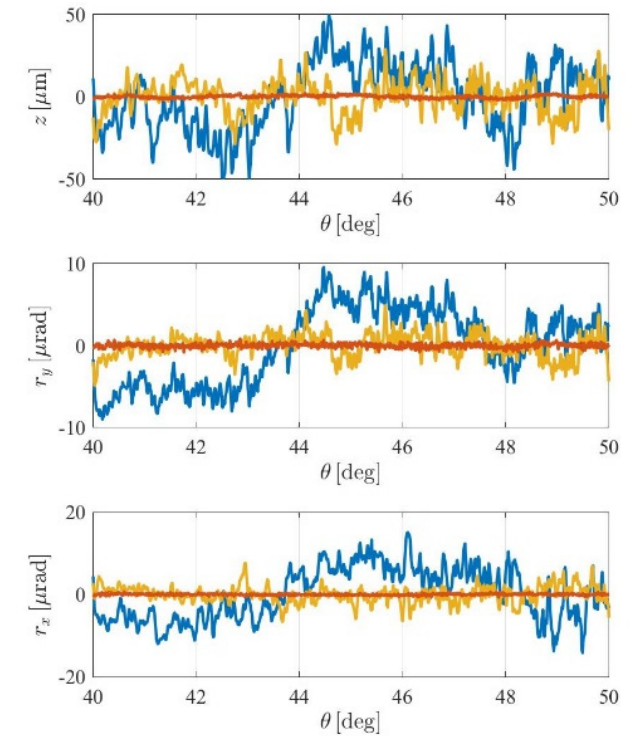
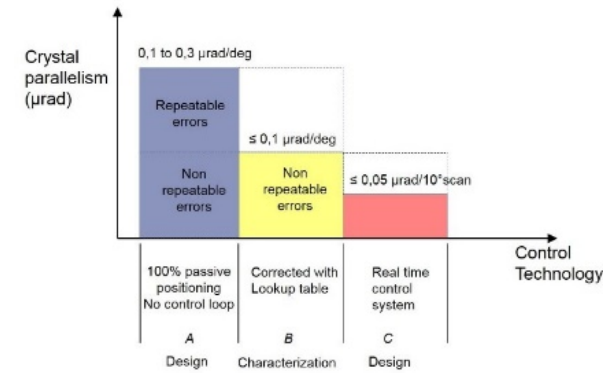

4. CONCLUSION

- **The control concept:**
 - follows the design principles
 - improves beam position stability by changing from mode A to B to C
 - works in degraded modes
- **Performance and field tests**
 - Final performance characterization still limited by laser setup
 - Dynamic scans not yet implemented and tested
 - No thermal effects detectable with laser set-up

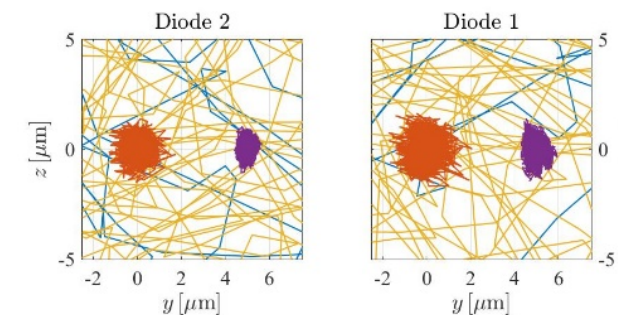
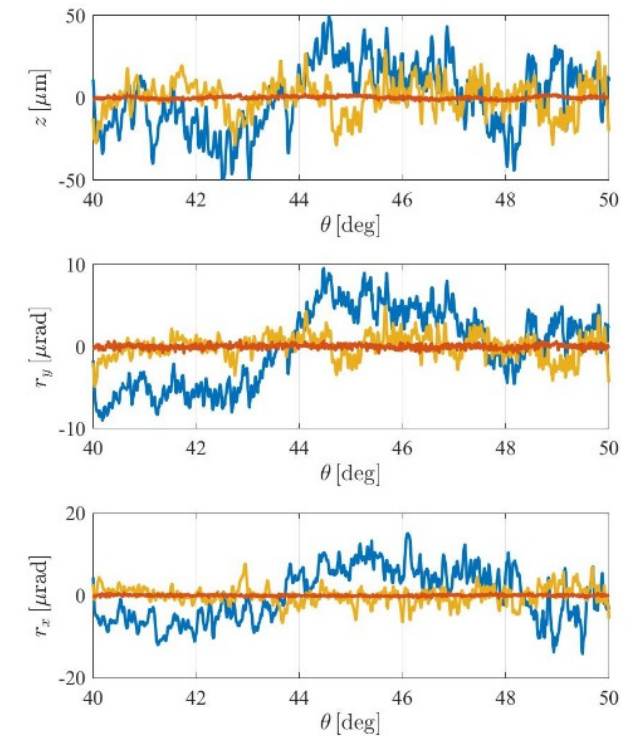
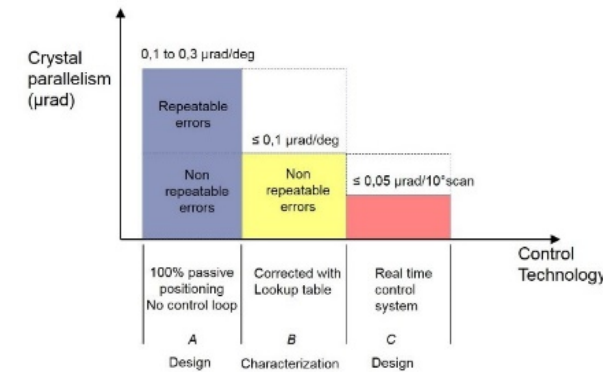

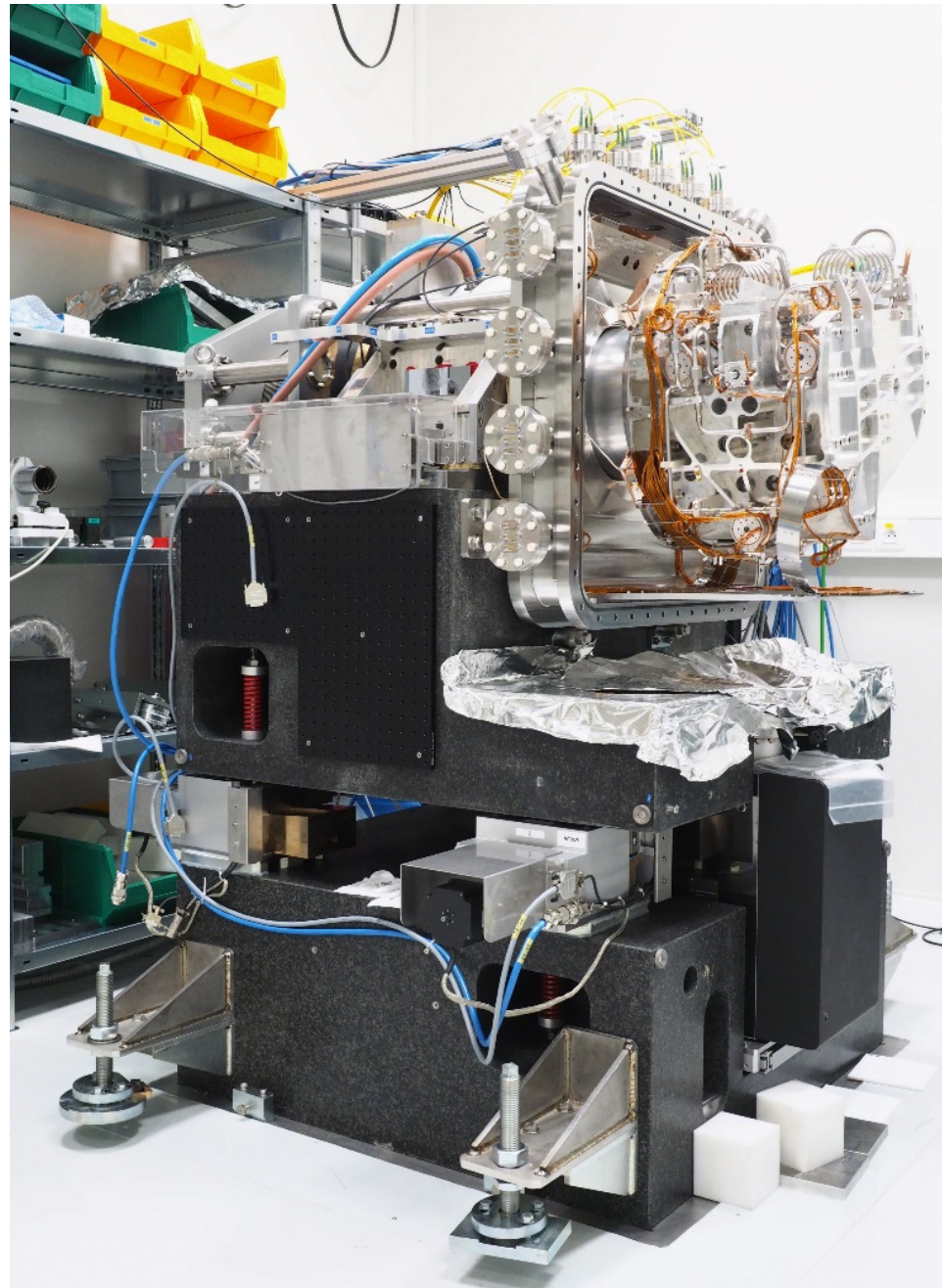

Special thanks to the full ESRF-DCM team:

Julien Bonnefoy
Nicolas Sevelin-Radiguet
Delphine Baboulin
Ray Barrett
Pascal Bernard
Philipp Brumund
Yves Dabin
Giovanni Malandrino
Philippe Marion
Olivier Mathon
Thomas Roth
Remi Tucoulou
ID21 – team
PAMU & PDMU team

...



Thank you for your attention!