



DE LA RECHERCHE À L'INDUSTRIE



SCIBORG : ANALYZING AND MONITORING LMJ FACILITY HEALTH AND PERFORMANCE INDICATORS

October 11th, 2019

Jean-Philippe Airiau / CEA-CESTA

Monitoring and analyzing critical data (or indicators) of the LMJ is essential to operate such a facility. It contributes to manage availability and planning actions for the new experiments and follow the global performances for the achieved experiments.

Need of a global tool able to perform these features :

- Extraction, transformation and storage of elementary data in a homogeneous format
- Computation of complex data from elementary data ($z=f(a,b,c,...)$), ex.: total energy on target), physical value (transfer function), security factor (vacuum windows damages)
- Monitoring temporal evolution of indicator (elementary data) and performances (complex data or physical value), performing security analysis (security factor)
- Crossed analysis $y = f(x)$ (ex. amplification gain vs energy bank efficiency)
- Smart GUI including rules on data (ex.: warning on threshold overcoming) and multiple types of chart for analysis
- Continuous Analysis : dashboard creation based on analysis synthesis
- Predictive analysis: predictive maintenance (planning of optic's replacement), calibration (fine tuning of coefficient used on embedded software)

- Extract, Transform and store in database (homogeneous format and metadata)
- Storage access and availability
- Analysis
 - Continuous : reporting, monitoring = short response time event detection
 - Predictive : behaviour pattern matching, machine learning= long response time event detection

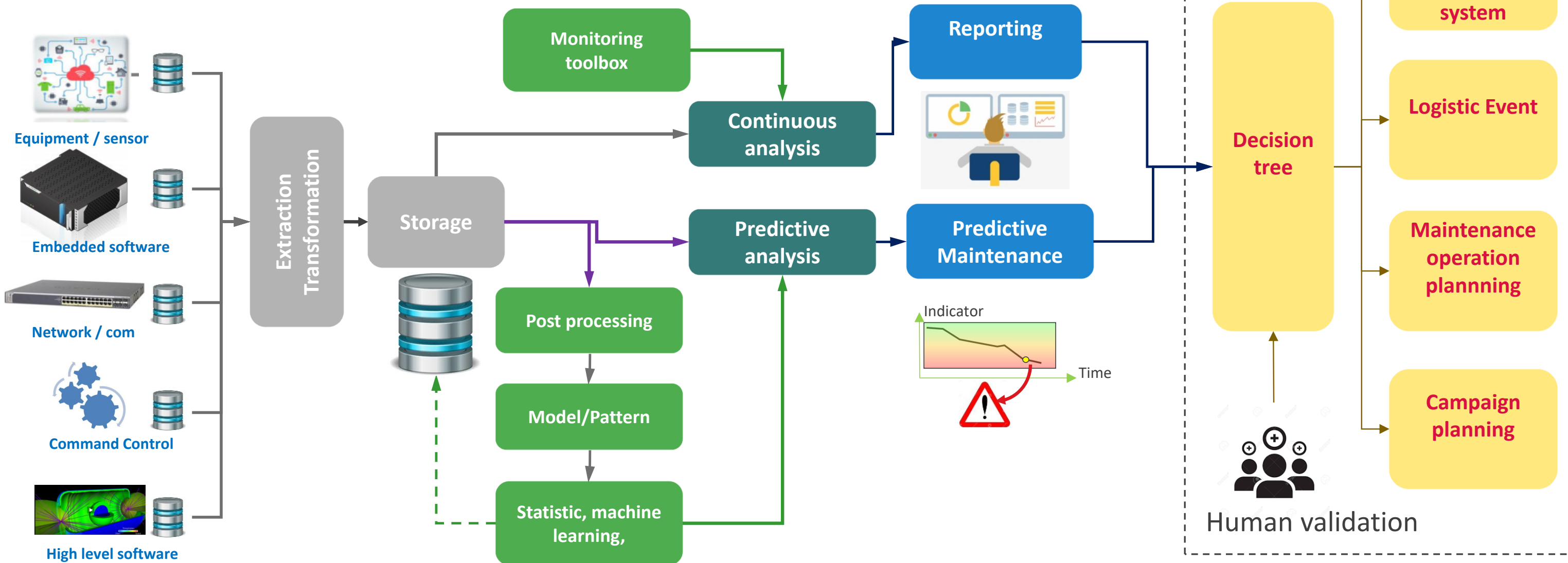

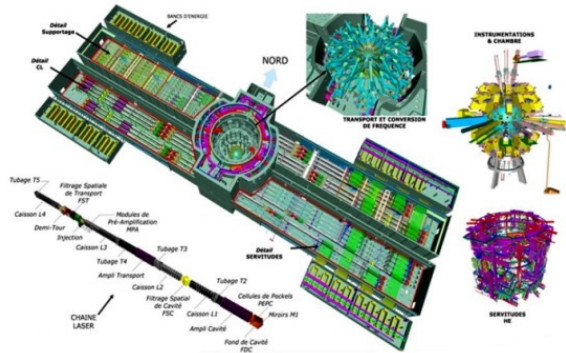
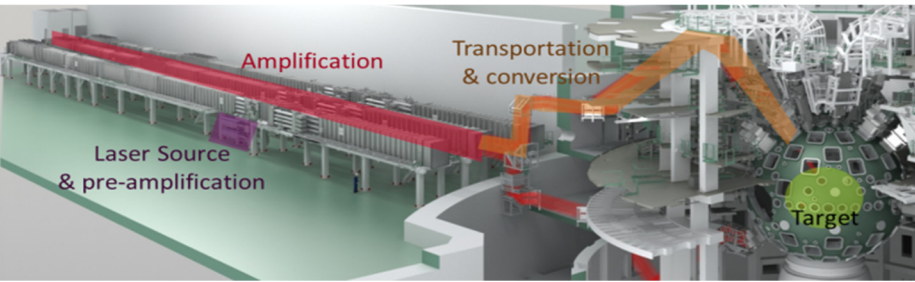

22 bundles / 44 quads / 176 beams

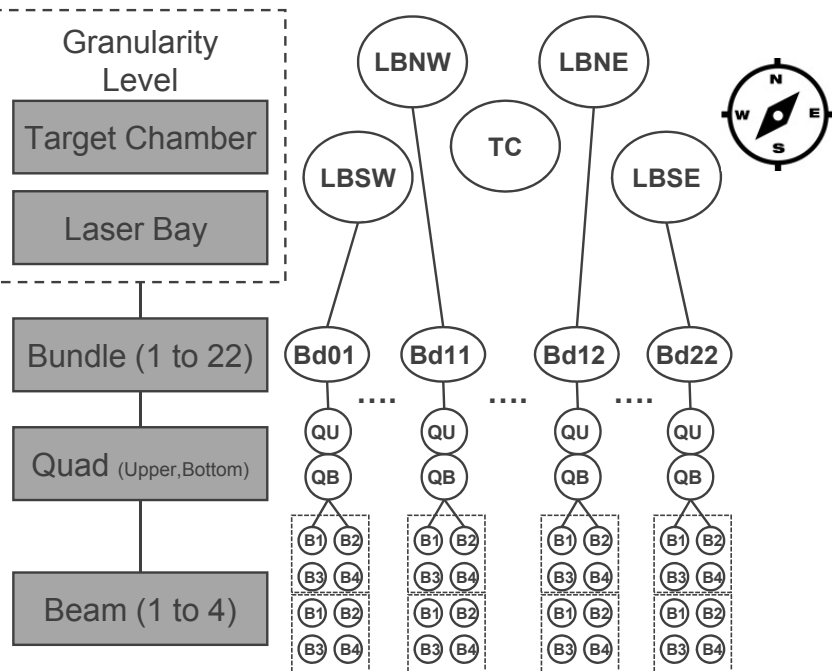

- LMJ facility design
- Granularity level concept
- Control command architecture
- List of indicators to monitor

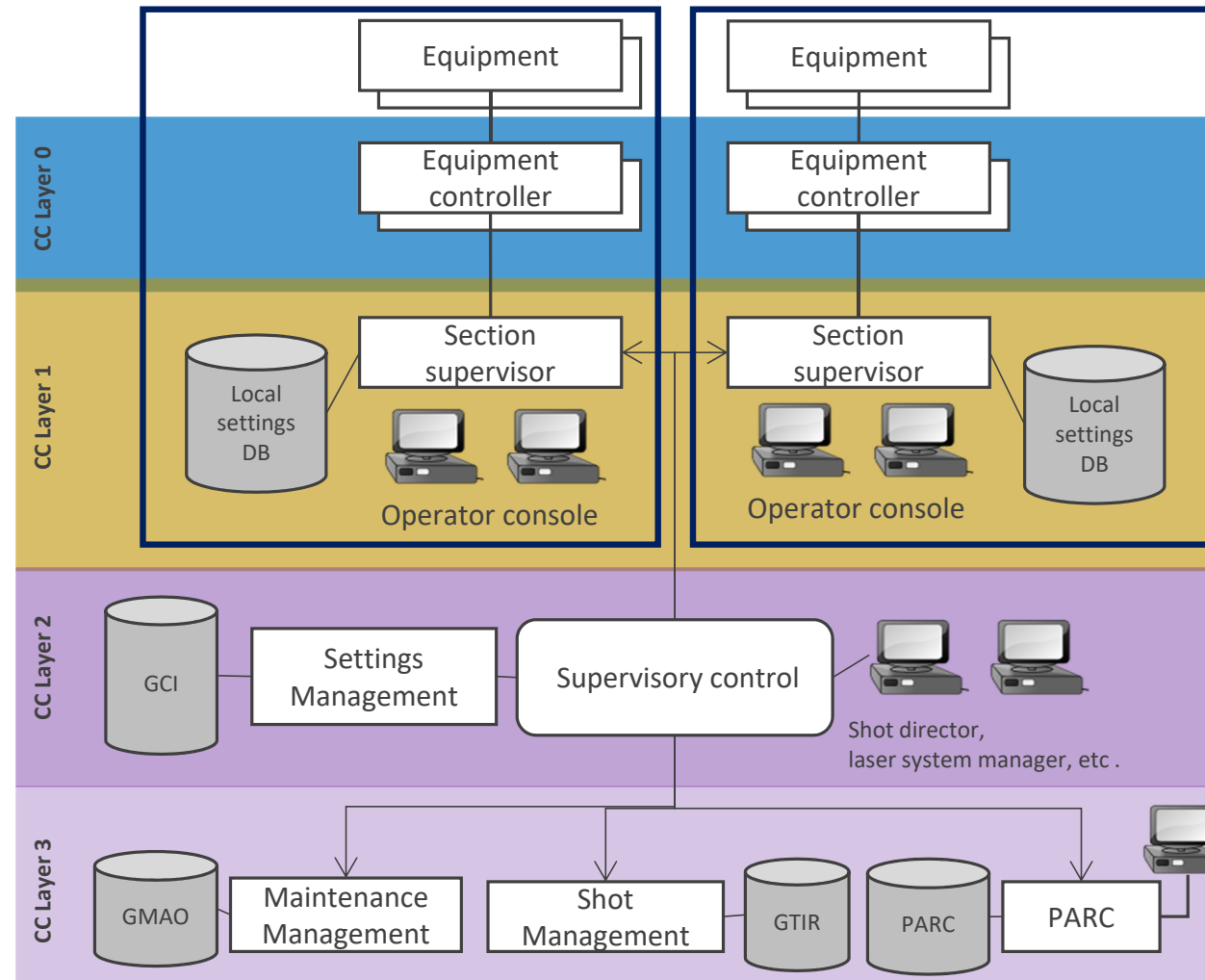

GCI : LMJ settings management system GTIR : LMJ shot results management system
 GMAO : LMJ logistic management system PARC : LMJ simulation system for prediction, results computation and models calibration

Indicators

- Hardware log and IT monitoring
- Network monitoring
- L0 level control equipment (log and I/O parameters)
- L0 embedded software (log and I/O parameters)
- L0/L1 communications
- L1 operating software
- L2 operating software
- Facility configuration parameters
- Raw and transformed results
- Physical values
- Maintenance event

Iterative development

- **LEOPOLD (2015/2019) : JAVA/JavaFx(Gui)/H2(DB)**
 - Benefits : quick development and maturation, easy access and use
 - Limitations : performances decrease for more than 2 bundles, no scalability
- **SCIBORG (2019/2025) : Web App, Angular JS, D3JS, Apache, Django, Python**
 - Benefits : easy access and use (WebApp), flexibility (complex data, rules , data processing definition with python script), scalability
 - Limitations : reduced perimeter, no predictive tools
- **LMJ Dr (2025,...) : full features**

Constraints

- **Independence: no impact on the facility performances, no modification on existing systems**
- **Scalability: adaptation to bundle extension (up to 22 bundles)**
- **Sustainability: must operate more than 10 years.**



Client :

- Easy access, deployment and longevity: WEB interface (Angular JS),
- Rich web-oriented visualization toolkit: D3JS (feedback from lab's developers),

Server

- Django/python , python script API (feedback from PARC)

Database:

- MongoDB (API (Django/python), easy deployment and scalability (sharding)).

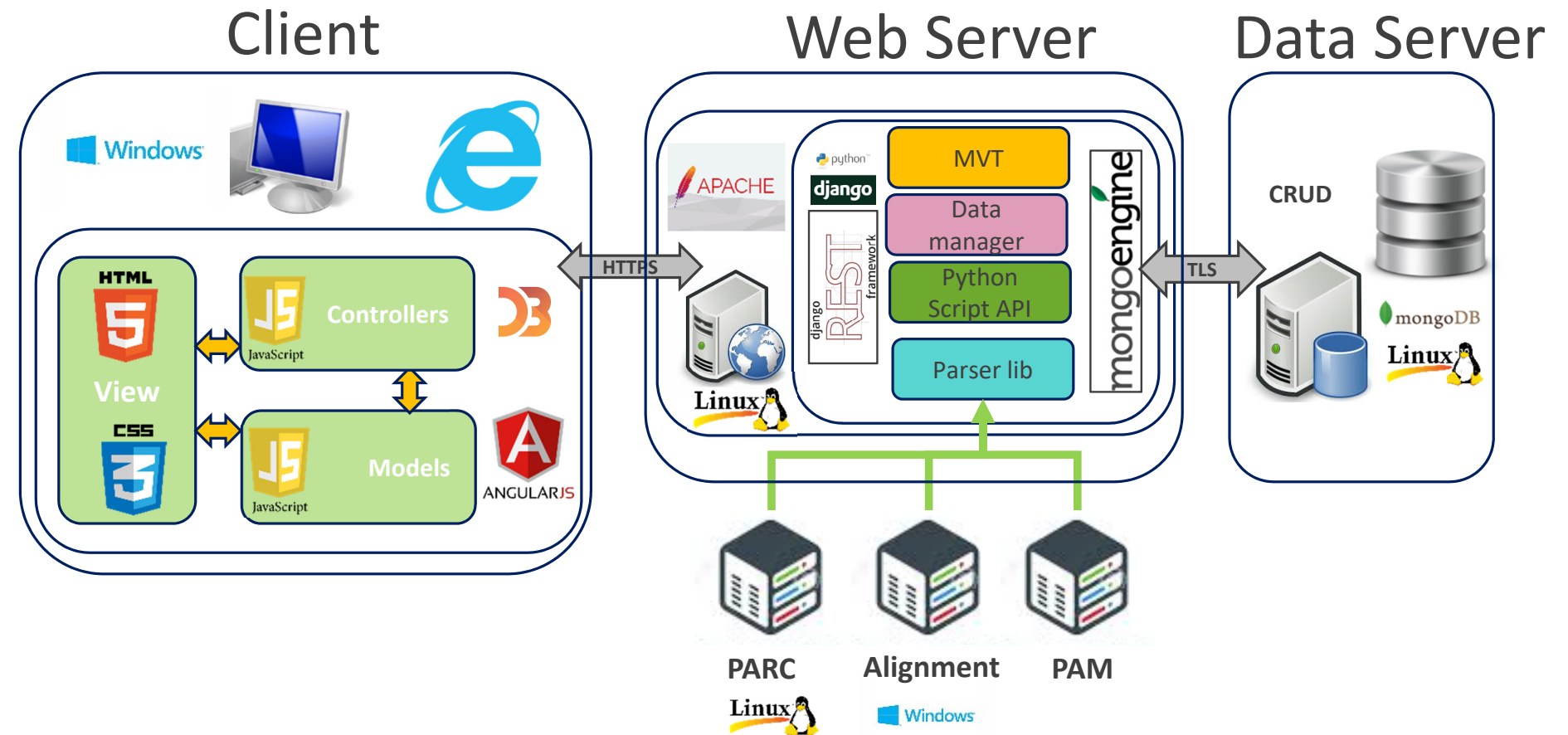

**Template file line**

Sciborg id	Data file path	Data memory path	Data name	Source	Import	Granulari	Type	Unit	...	
	RESULT/\${CampaignId}	RESULT/\${CampaignId}/\${ShotId}/\${ExecutionId}/\${Cli}	TC/ENERGY	Energy	PARC	MANUAL	Bundle	double	J	...



)



Template file line

Sciborg id	Data file path	Data memory path	Data name	Source	Import	Granulari	Type	Unit	...
RESULT/\${CampaignId}	RESULT/\${CampaignId}/\${ShotId}/\${ExecutionId}/\${Cli}	TC/ENERGY	Energy	PARC	MANUAL	Bundle	double	J	...

Import type

Manual
Import

Automatic
import

)



Sciborg id	Data file path	Data memory path	Data name	Source	Import	Granulari	Type	Unit	...
RESULT/\${Campaign}	RESULT/\${CampaignId}/\${ShotId}/\${ExecutionId}/\${Cli}	TC/ENERGY	Energy	PARC	MANUAL	Bundle	double	J	...



Template file line

Import type

Identification

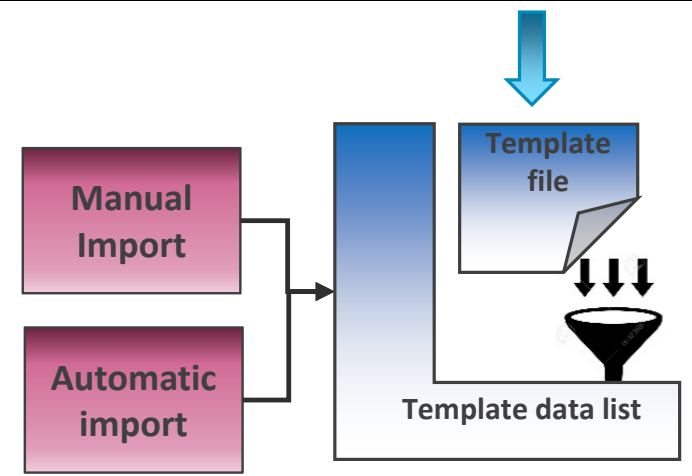

)



Template file line

Sciborg id	Data file path	Data memory path	Data name	Source	Import	Granulari	Type	Unit	...
RESULT/	RESULT/	TC/ENERGY	Energy	PARC	MANUAL	Bundle	double	J	...

Import type

Identification

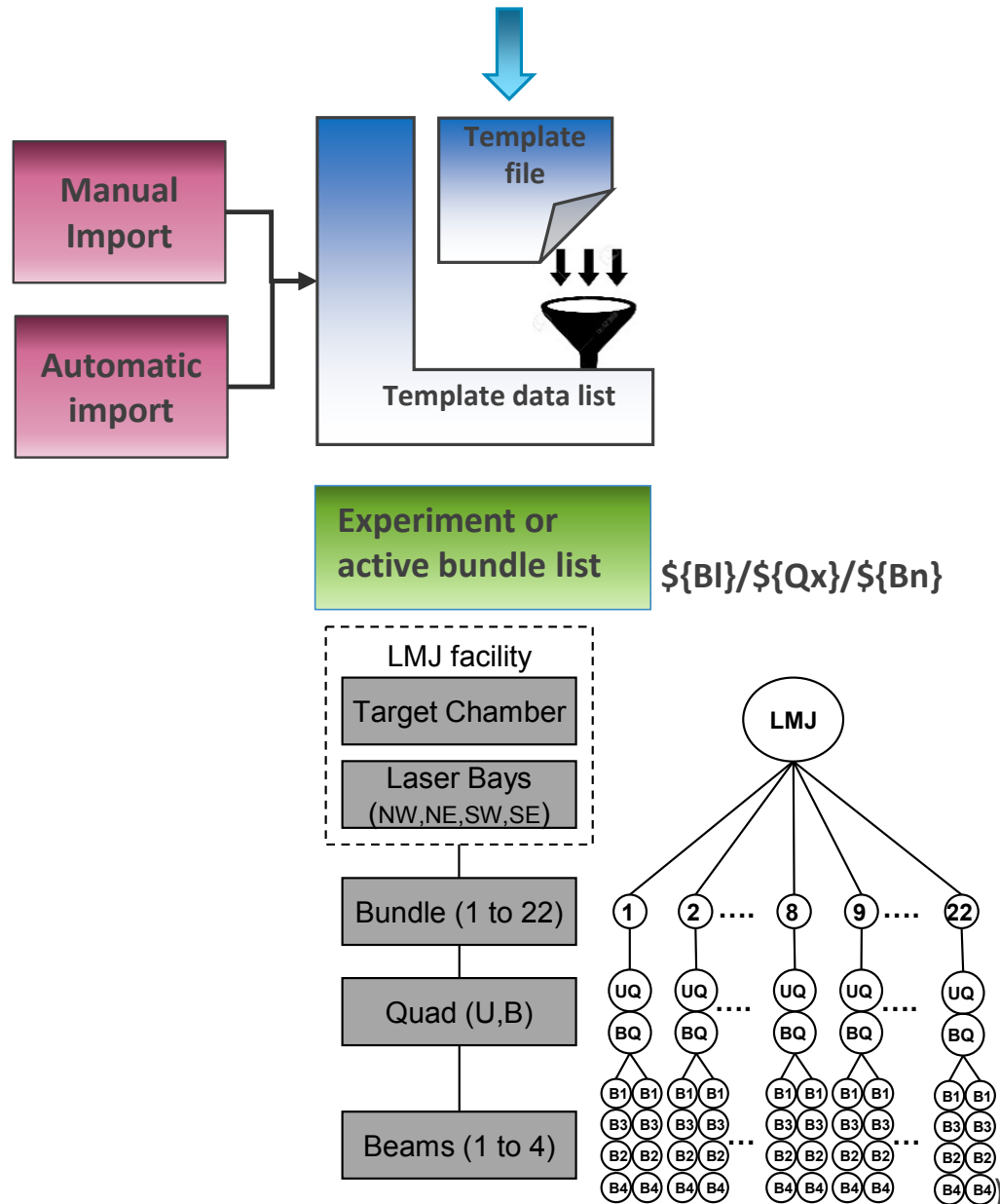



Template file line

Sciborg id	Data file path	Data memory path	Data name	Source	Import	Granulari	Type	Unit	...
RESULT/	RESULT/	TC/ENERGY	Energy	PARC	MANUAL	Bundle	double	J	...

Import type

Identification

Instantiation

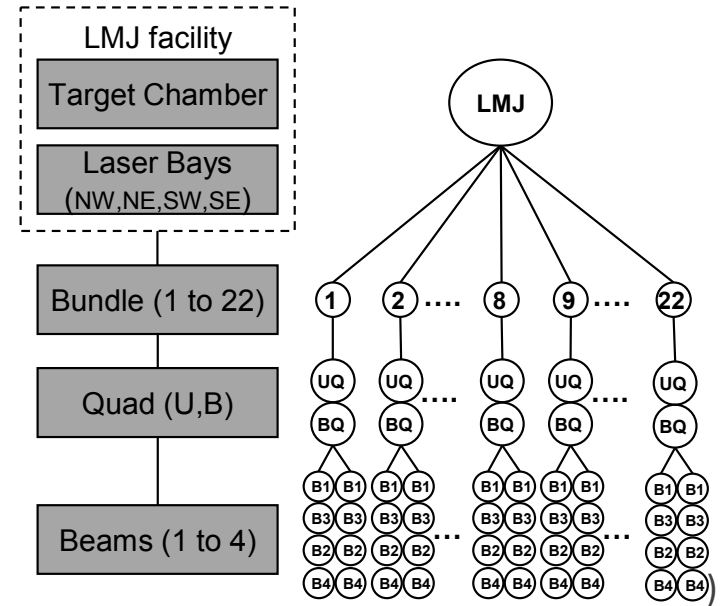
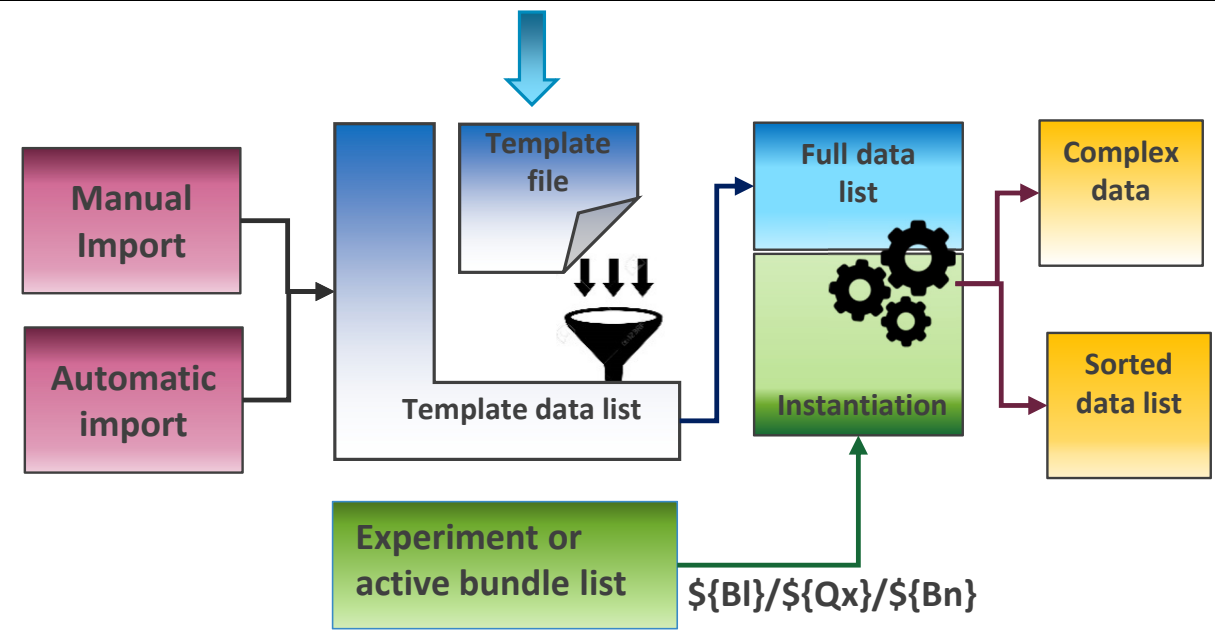



Template file line

Sciborg id	Data file path	Data memory path	Data name	Source	Import	Granulari	Type	Unit	...
RESULT/\$_{Campaign}	RESULT/\$_{CampaignId}/\$_{ShotId}/\$_{ExecutionId}/\$_{CLI}	TC/ENERGY	Energy	PARC	MANUAL	Bundle	double	J	...



Import type

Identification

Instantiation

Parsing process

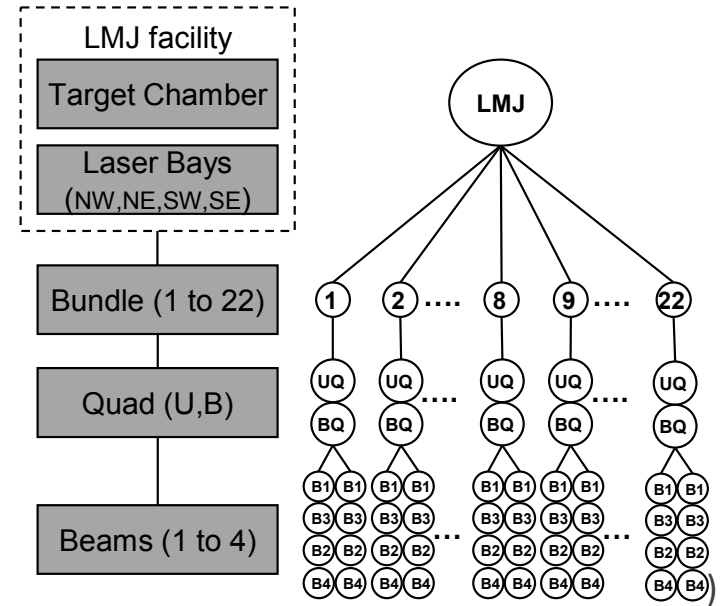
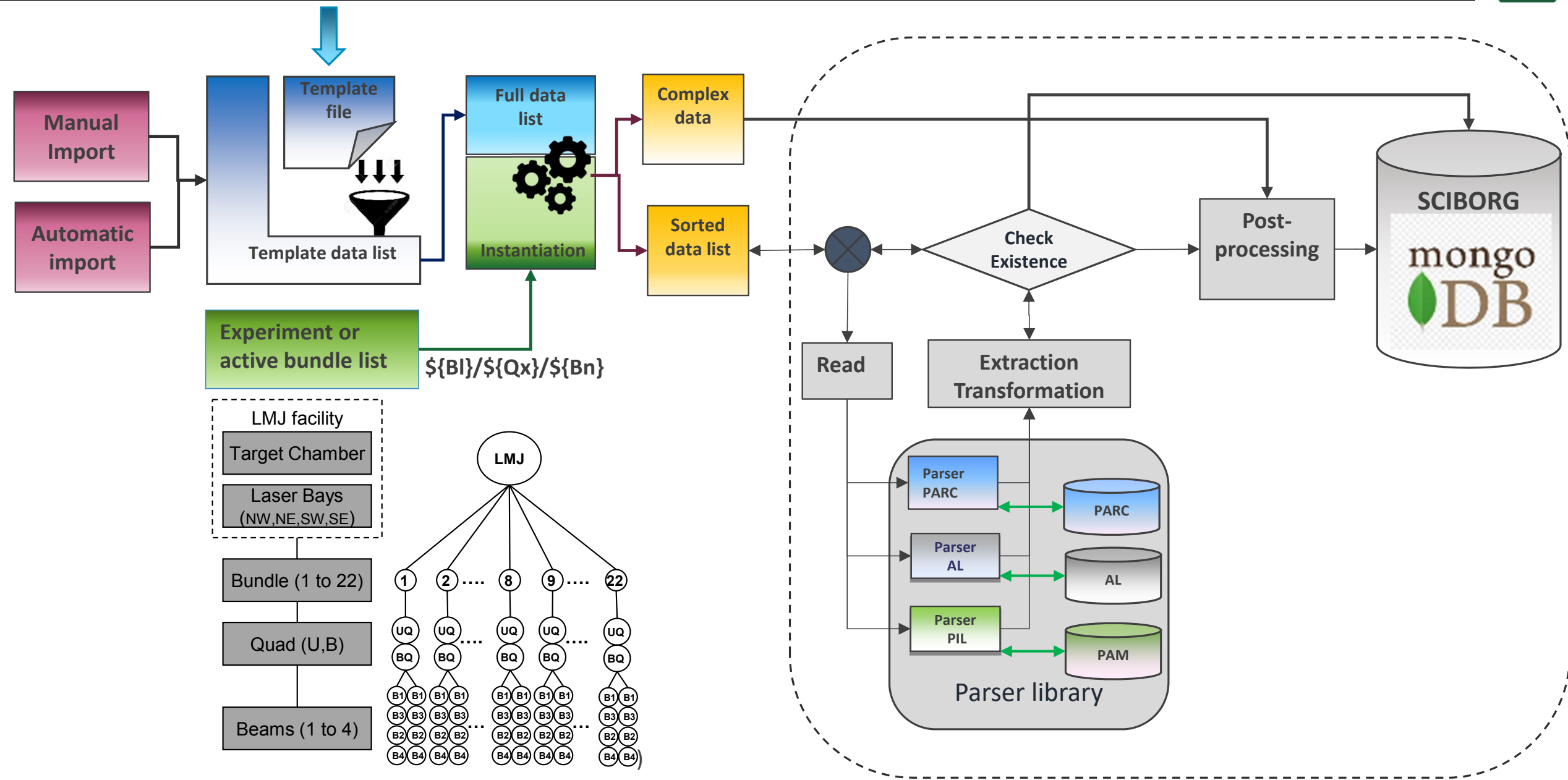



Template file line

Sciborg id	Data file path	Data memory path	Data name	Source	Import	Granulari	Type	Unit	...
RESULT/\$_{Campaign}	RESULT/\$_{CampaignId}/\$_{ShotId}/\$_{ExecutionId}/\$_{CLI}	TC/ENERGY	Energy	PARC	MANUAL	Bundle	double	J	...



Import type

Identification

Instantiation

Parsing process

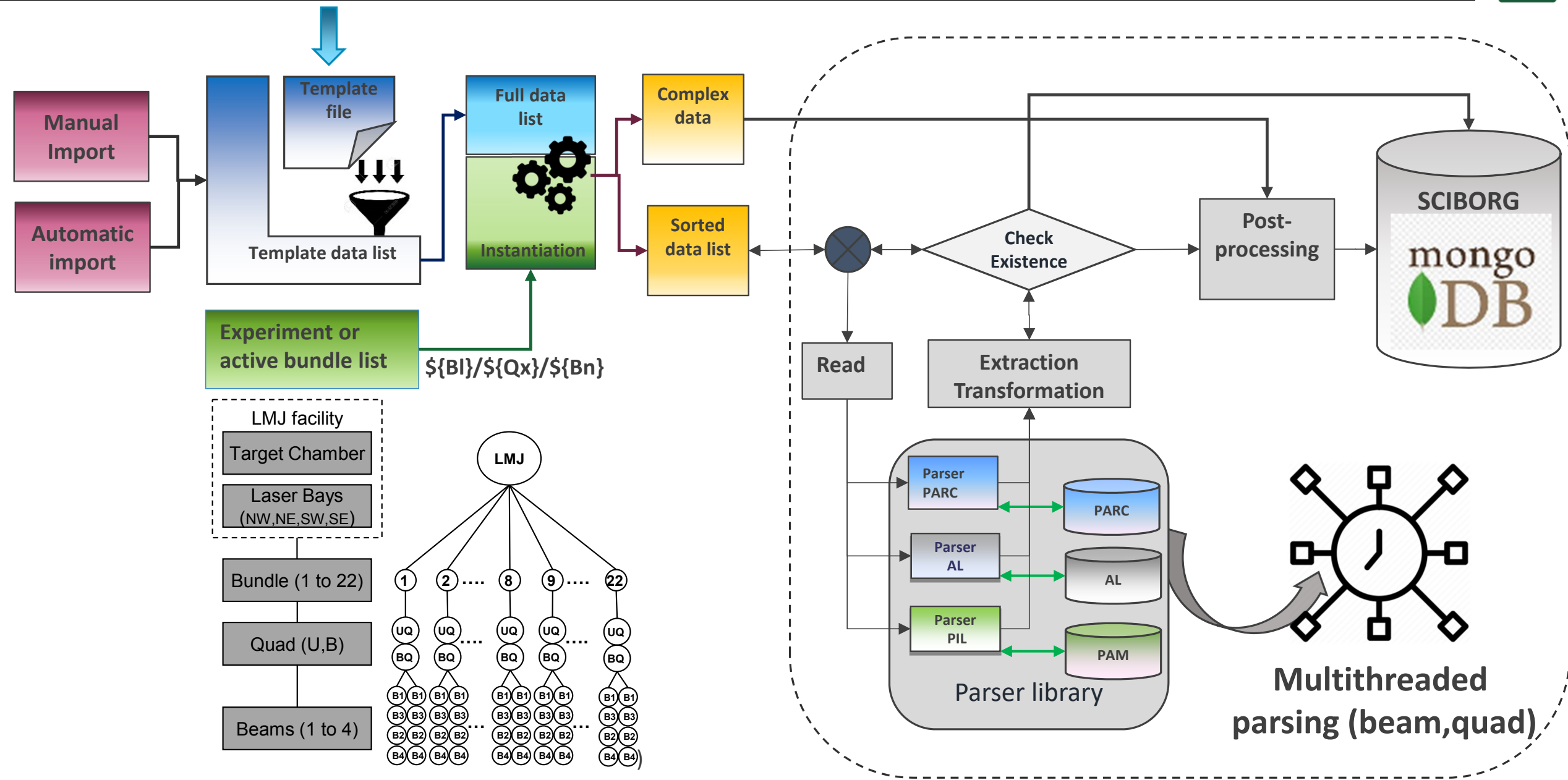



Sample consistency (different extraction sampling rate)

- $y = f(x)$ nb. $x \neq \text{nb. } Y \rightarrow$ Double padding algorithm

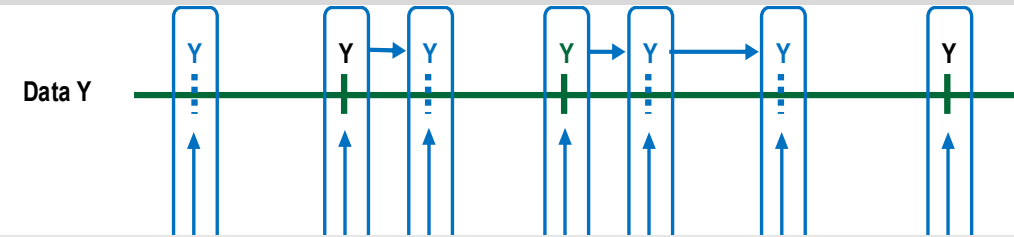

Data selection
 $y=f(x) / y=f(t)$

Association
 $Y(\text{beam}) \leftrightarrow X(\text{beam})$
 $Y(\text{quad}) \leftrightarrow Y(\text{beam})$

Plotting

- Settings
- Filters
- Data processing

Save
load

Export

SCIBORG User :

Admin Donnée Tirs Timeline **Analyses** Tableaux de Bord Préférences

GROUPES + g5 ↓

TITRE	TYPE	ABSCISSES	ORDONNEES	ASSOCIATIONS
<p>Nom du groupe g5</p>	<p>Type d'analyse</p>	<p>+ ×</p>	<p>+ ×</p>	<p>+ × ~</p> <p style="font-size: small; color: red;">Associations Noms courbes</p>

GRAPHIQUES

SCIBORG Version 20180117



- A complex data is a new indicator resulting from a computation of stored data (Ex. Mean value)
- A rule is a simple or complex condition applied on shot report data (Ex. If $\text{Min} < \text{value} < \text{max} = \text{OK}$)
- A data processing is a computation used to transform the dataset of an analysis (Ex. : Smooth filter)



- A complex data is a new indicator resulting from a computation of stored data (Ex. Mean value)
- A rule is a simple or complex condition applied on shot report data (Ex. If Min < value < max = OK)
- A data processing is a computation used to transform the dataset of an analysis (Ex. : Smooth filter)

Definition

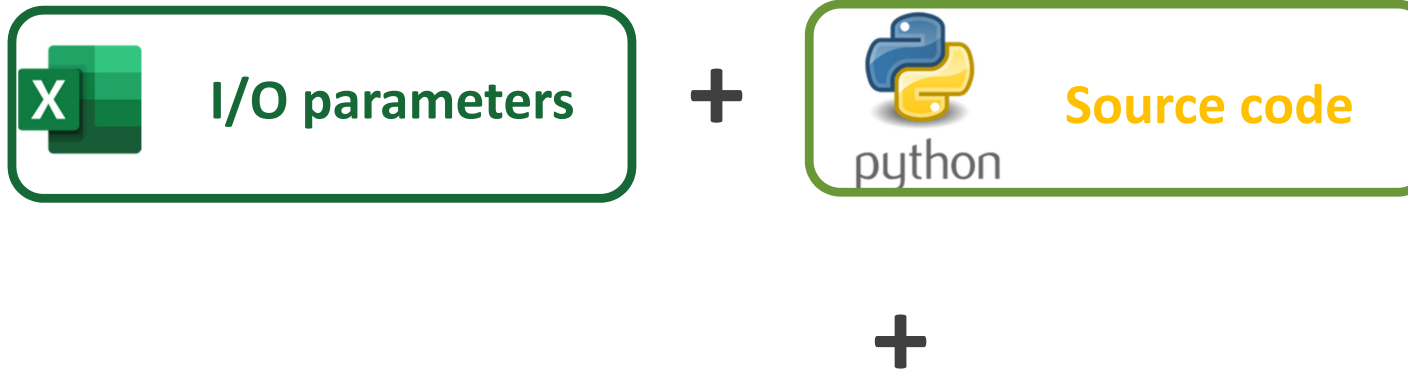



- A complex data is a new indicator resulting from a computation of stored data (Ex. Mean value)
- A rule is a simple or complex condition applied on shot report data (Ex. If $\text{Min} < \text{value} < \text{max} = \text{OK}$)
- A data processing is a computation used to transform the dataset of an analysis (Ex. : Smooth filter)

Definition

Complex data

Rules

Data Processing

The screenshot displays the SCIBORG web application interface. The top navigation bar includes 'Admin Donnée', 'Tirs', 'Timeline', 'Analyses', 'Tableaux de Bord', and 'Préférences'. Below this, a secondary navigation bar lists 'Import', 'Valider les Données', 'Upload de Fichiers', 'Association Règles/Données', 'Consultation Données Calculées' (which is highlighted), 'Consultation Traitements', and 'Gestion des Utilisateurs'. The main content area is divided into several sections:

- Modèles de donnée calculée:** A list with checkboxes for 'MeanValue' and 'moyenneCalculee', and an 'Ajouter modèle' button.
- Filtres Données:** A section with dropdown menus for 'Granularité', 'Source', and 'Phase', and 'Annuler' and 'Valider' buttons.
- Filtrer la dénomination:** A section with a 'Données BDD' label.
- Table:** A central table with columns 'Paramètre', 'Description', 'Type', 'Valeur', and 'Unité'. A mouse cursor is visible over the table.
- Instances de données calculées:** A section with a checkbox for 'Test'.
- Buttons:** 'Editer' and 'Enlever' buttons are located at the bottom right, and 'Quitter l'édition' and 'Application' buttons are at the bottom center.

The footer of the application shows 'SCIBORG Version 20180117'.



Dashboards contain analysis or data (even external data).

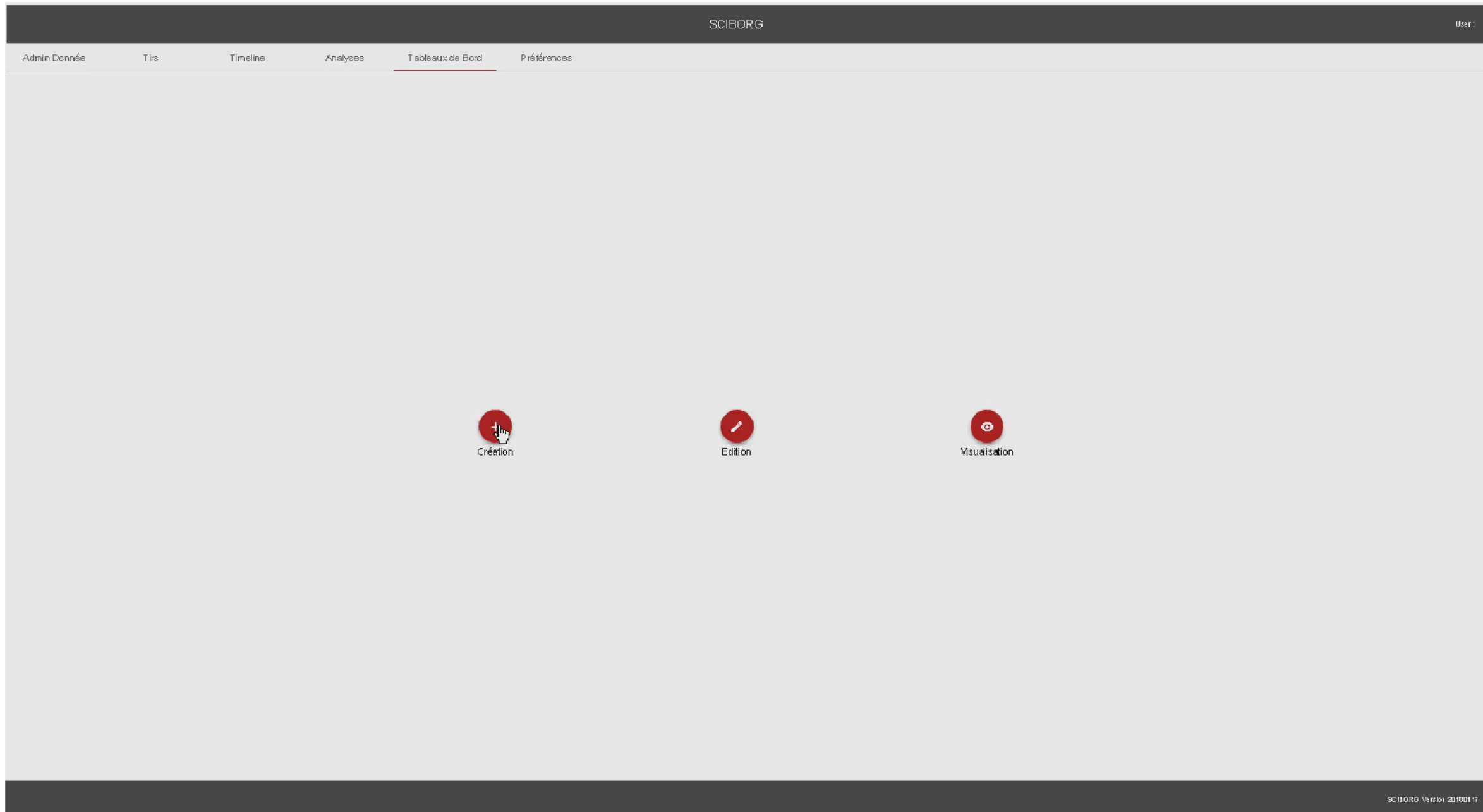

Creation
/edition

Save/load

Visualize

Export

Users : laser engineer

Example : Final Optic Assembly (FOA) alignment

Processus :

1. Common Reference (CR) laser illuminates Alignment Reference Phase plate (ARP)
2. ARP are set to autocollimation = 4 spots (reflected focused light from ARP) on RC sensor (1)
3. Each ARP are moved to focalize at the same point = 1 spot on RC sensor (1 bis)
4. FOA moves to the specified position = 1 spot centered on RC sensor

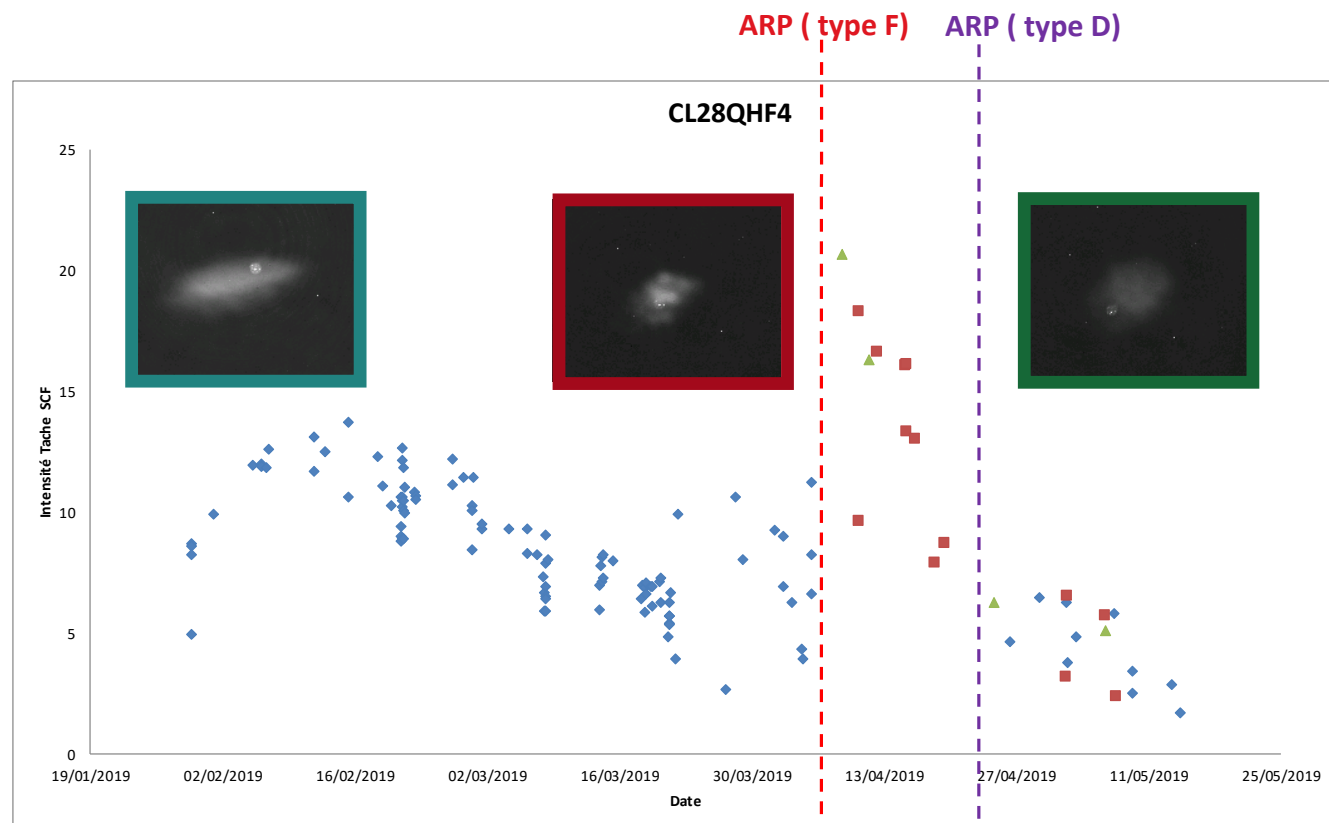
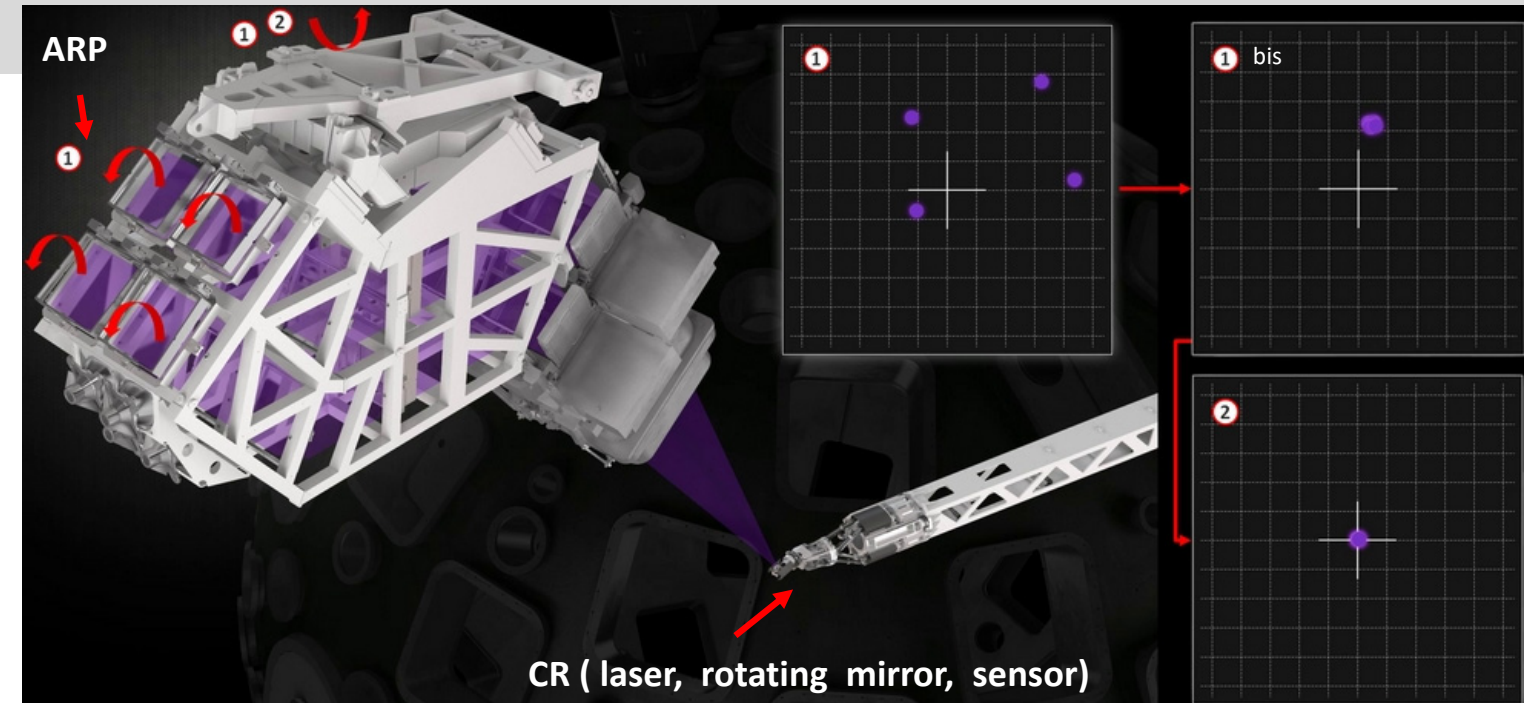

Issue : Decrease of focal spot intensity on RC sensor

Quick fix : change ARP type, optimize integration time (IT) of RC sensor

Sciborg plot complex data

- Blue : intensity of focal spot on RC sensor ($IT > 1500$)
- Red : intensity of focal spot on RC sensor ($1200 < IT < 1500$)
- Green : intensity of focal spot on RC sensor ($IT < 1200$)

Conclusion :

Even changing ARP type and RC sensor integration time has no stable effects on focal spot intensity :

RC laser is going down and need quick replacement!

As a doctor, the final tool will help to investigate diagnosis and suggest a cure to an LMJ “illness”.

Adding missing features

- Extended data perimeter
- Predictive analysis (toolbox and link with DB)

Milestones

- **LMJ facility domain expert interviews (2019)**
 - IT (hardware & network)
 - Equipment (PLC, Motor, sensor, diagnosis, etc.)
 - Control command ingeneer
 - All application fields specialist(Laser, Sync, ..)
- **Specifications (2022)**
 - External expertise for
 - Big data storage / access
 - High performance network
 - Feedback from Sciborg
- **Deployment (2025) - 22 bundles commissioned**

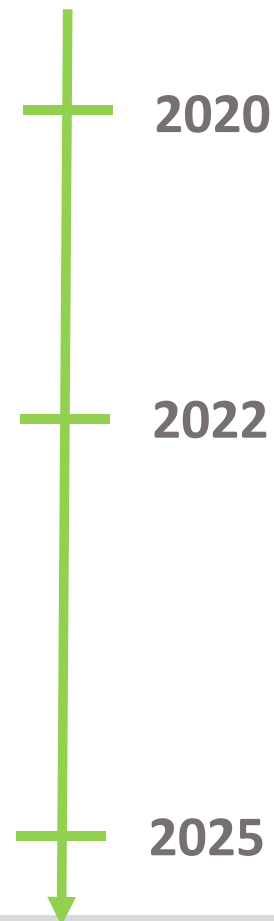

As a doctor, the final tool will help to investigate diagnosis and suggest a cure to an LMJ “illness”.

Adding missing features

- Extended data perimeter
- Predictive analysis (toolbox and link with DB)

Milestones

- **LMJ facility domain expert interviews (2019)**
 - IT (hardware & network)
 - Equipment (PLC, Motor, sensor, diagnosis, etc.)
 - Control command ingeneer
 - All application fields specialist(Laser, Sync, ..)
- **Specifications (2022)**
 - External expertise for
 - Big data storage / access
 - High performance network
 - Feedback from Sciborg
- **Deployment (2025) - 22 bundles commissioned**

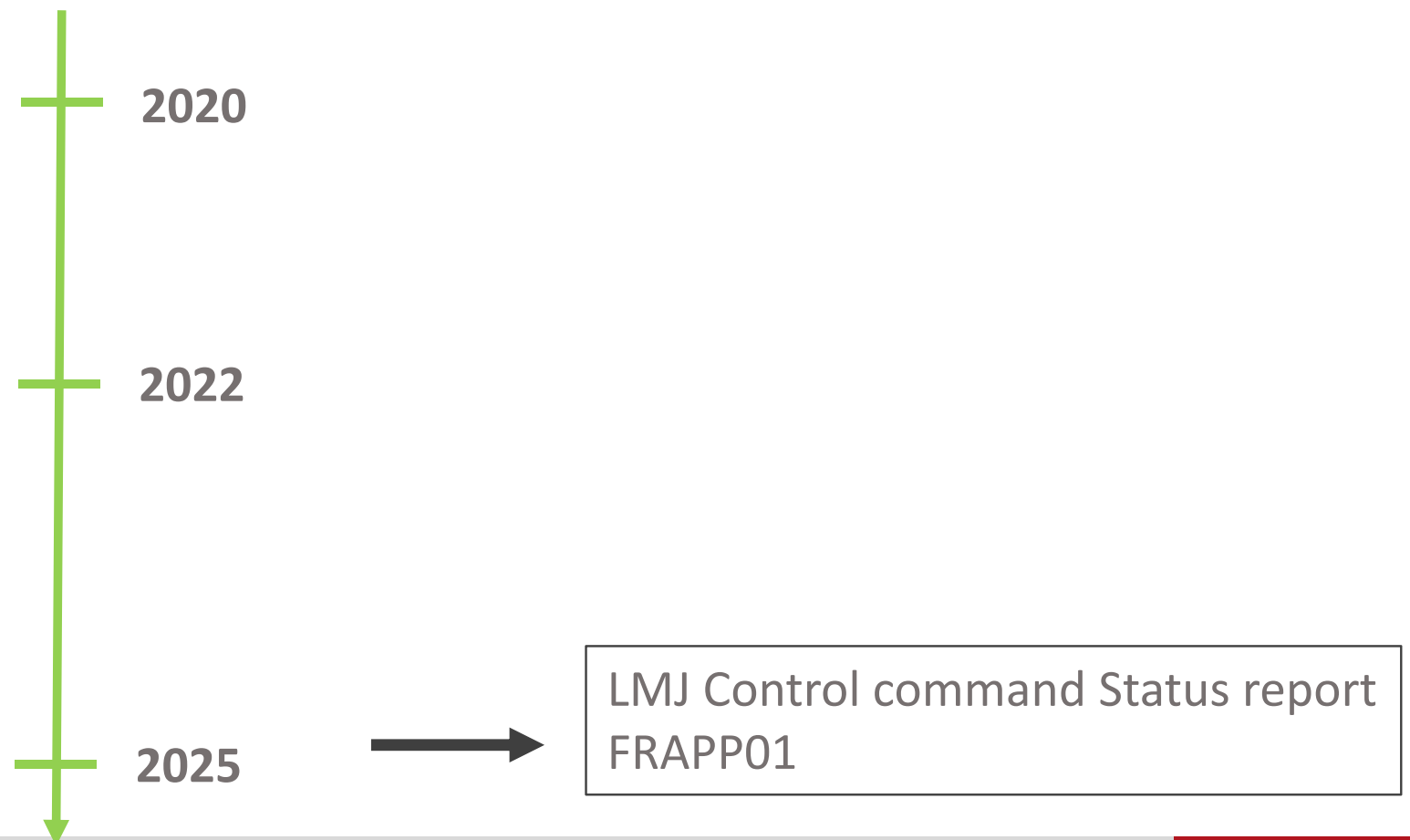



Thank you for your attention

Any questions ?

Jean-Philippe Airiau – jean-philippe.airiau@cea.fr