

Construction of Beam Monitor Control System for Beam Transport from SACLA to SPring-8

JASRI/SPring-8

○Akio Kiyomichi, T. Fukui, N. Hosoda,
M. Ishii, K. Maesaka, M. Yamaga

2019/10/10

Outline

- Overview of SPring-8/SACLA
- New control system for beam monitor
 - upgrade of SCM, BPM and CT
- GigE Vision camera control for screen monitor
- Beam test of camera system
- Summary

Overview of SPring-8/SACLA

3



Overview of SPring-8/SACLA

- SPring-8 is a 3rd generation light source facility. [operated since 1997]
 - Linac, Synchrotron, Storage Ring. Beam injection 1Hz and top-up operation.
- SACLA is a X-ray Free Electron Laser facility. [operated since 2011]
 - High-peak brilliance, spatial coherent, ultrafast X-ray pulse



SACLA
SPring-8 Angstrom Compact free electron LAser



Storage Ring

~500m

~700m

SSBT

Booster Synchrotron

Linac

Overview of SPring-8/SACLA

- SPring-8 is a 3rd generation light source facility. [operated since 1997]
 - Linac, Synchrotron, Storage Ring. Beam injection 1Hz and top-up operation.
- SACLA is a X-ray Free Electron Laser facility. [operated since 2011]
 - High-peak brilliance, spatial coherent, ultrafast X-ray pulse
 - It will Inject ultra-low emittance electron beam into storage ring in SPring-8-II.



SACLA
SPring-8 Angstrom Compact free electron LAser

Storage Ring
SPring-8



~700m

~500m

XSBT

SSBT

Booster Synchrotron

Linac

New Control System for Beam Monitor

- Ultra-low emittance beam injection → **Beam size is reduced**
 - Upgrade of beam monitors for XSBT/SSBT is required.
 - SCM: 24 at SSBT, 18 at XSBT

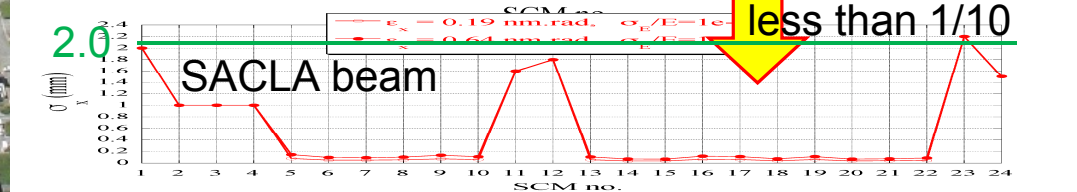
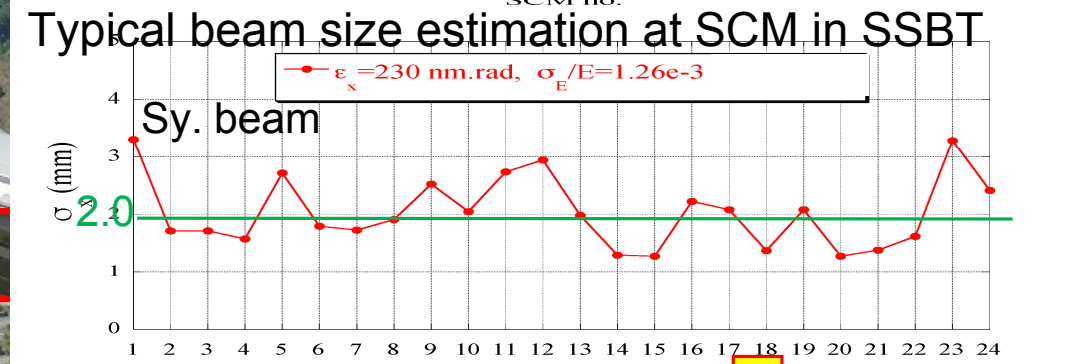
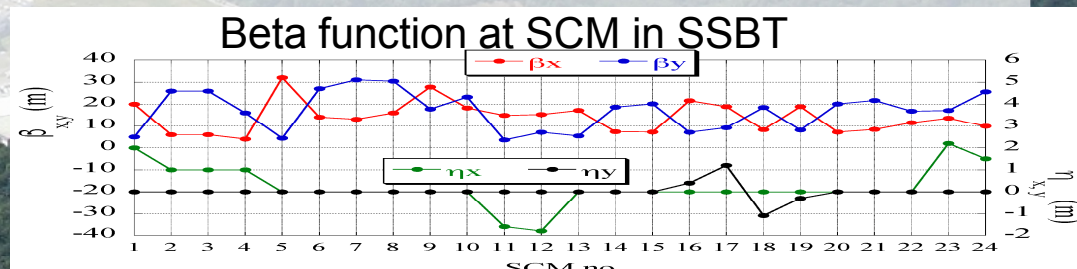
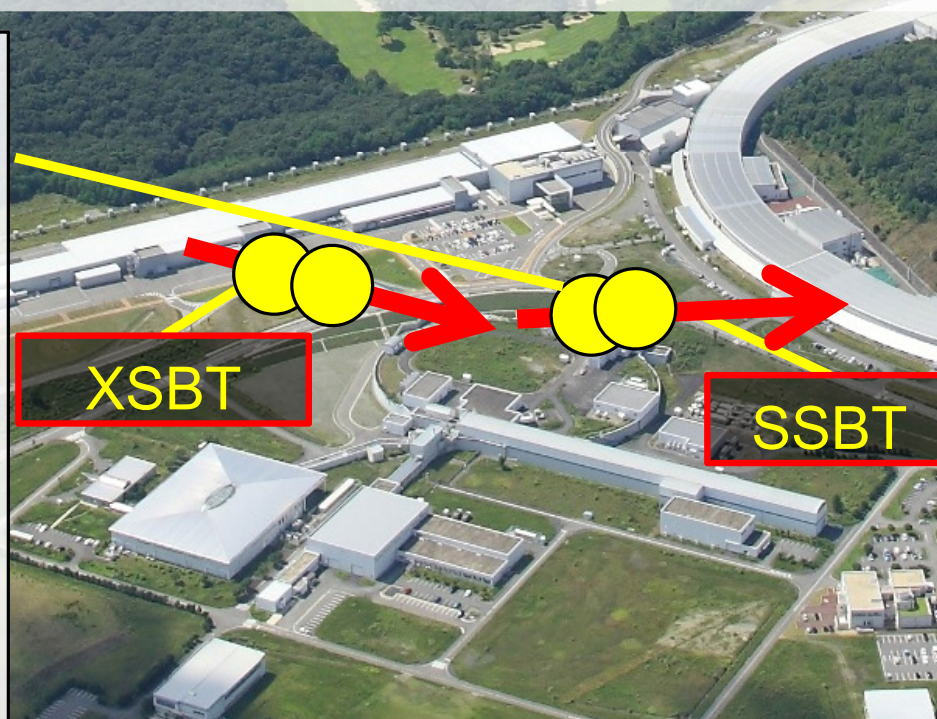
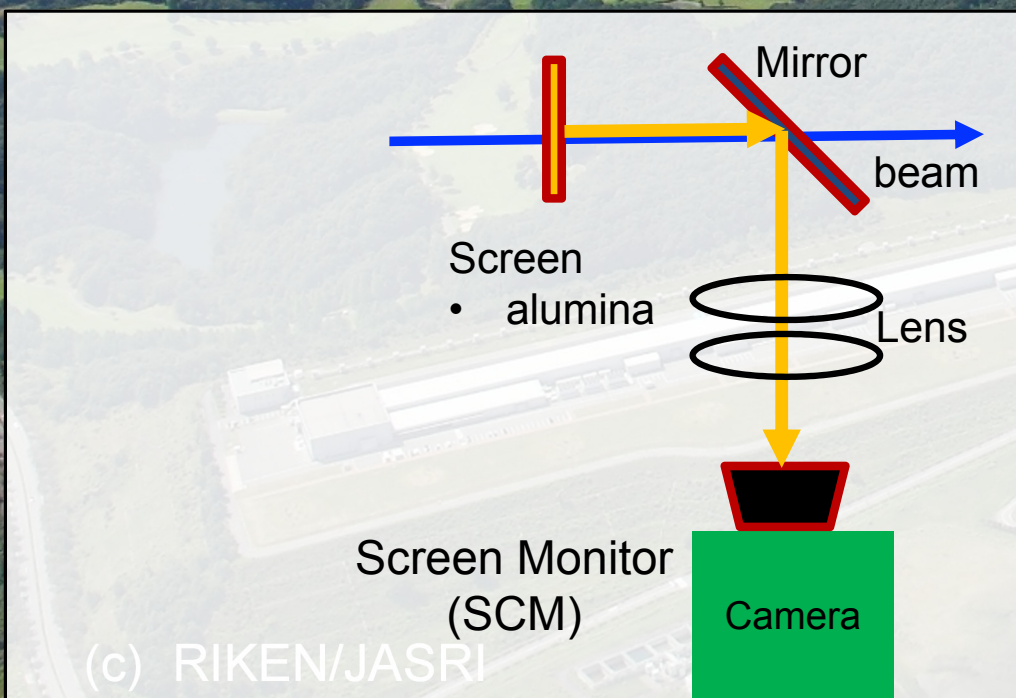

New Control System for Beam Monitor

- Ultra-low emittance beam injection → **Beam size is reduced**
 - Upgrade of beam monitors for XSBT/SSBT is required.
 - SCM: 24 at SSBT, 18 at XSBT → update SCM, replace or add with BPM&CT.
 - Screen : alumina fluorescent → **Ce:Yag scintillator**
 - Camera: VGA (0.3 M pixels) → **high-resolution (2 M pixels)**
- Finally becomes 30 SCMs, 30 BPMs, 10 CTs in total for XSBT and SSBT
- **The control system is also upgrade**

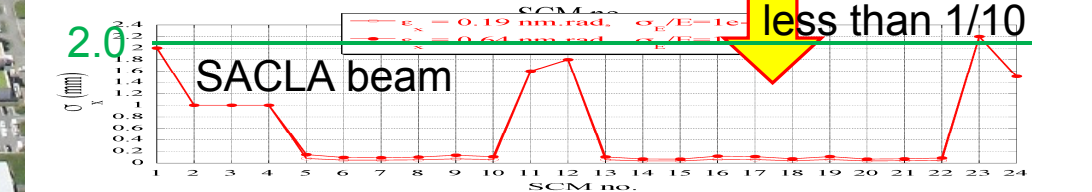
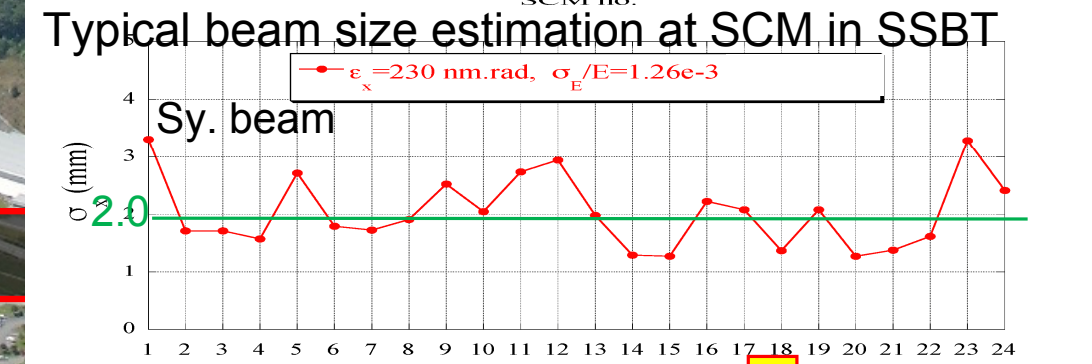
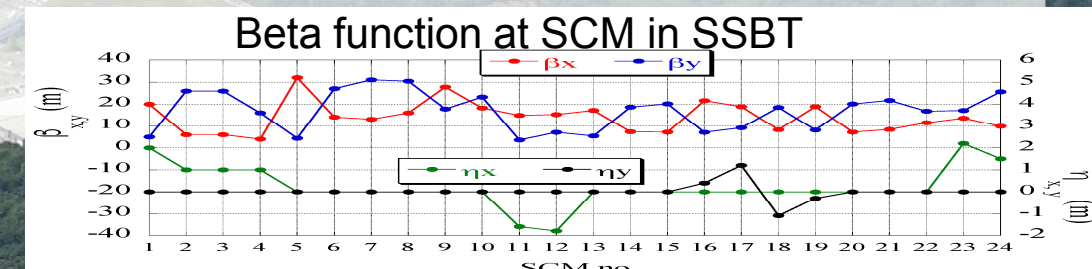
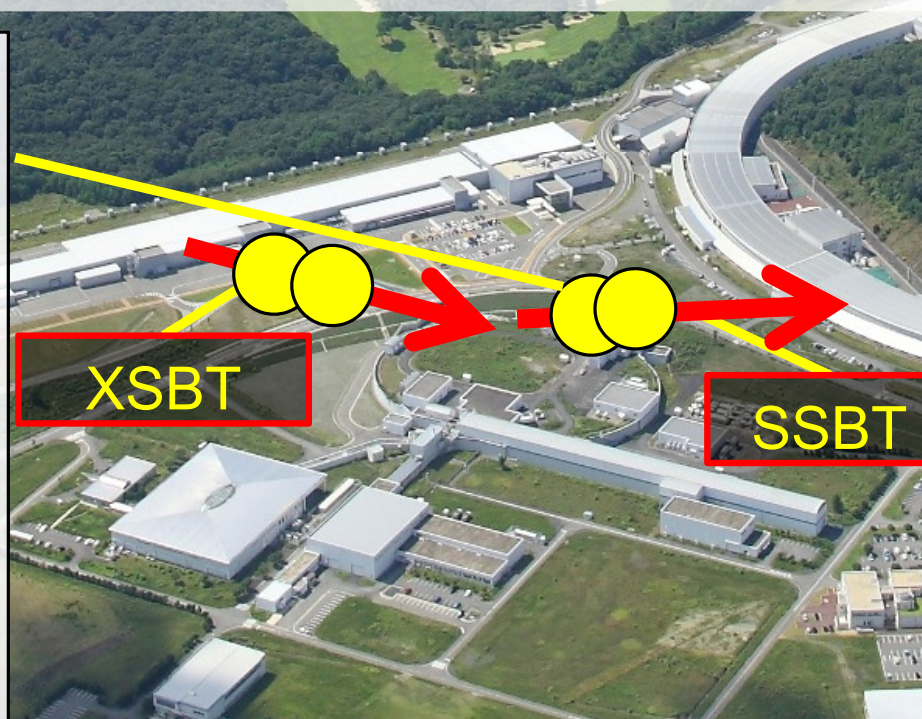
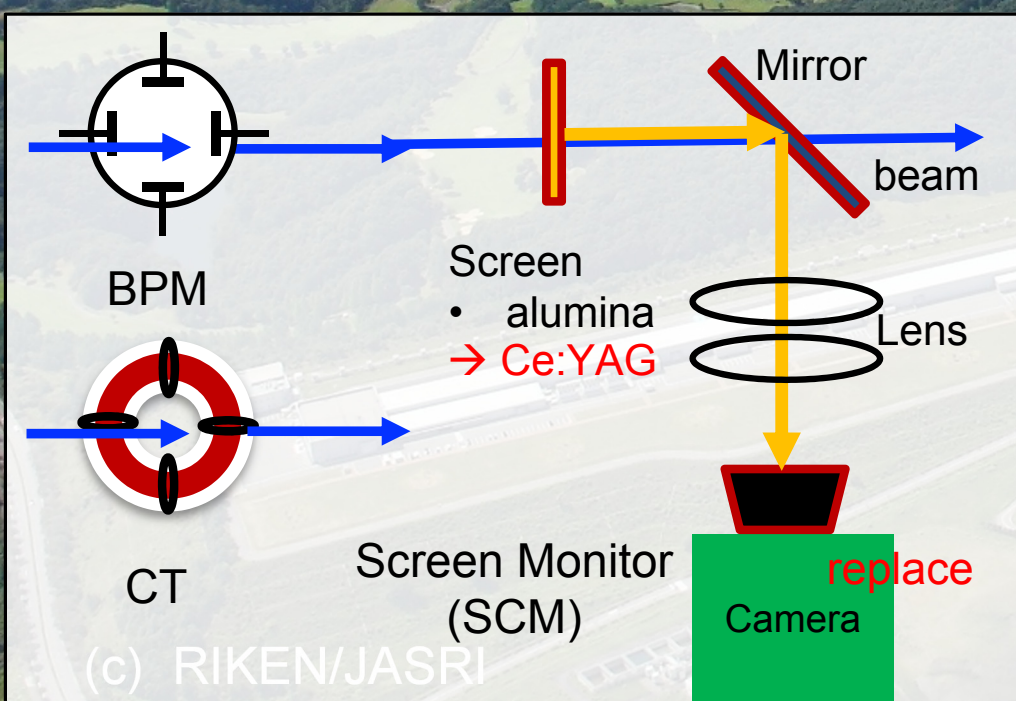

New Control System for Beam Monitor

Screen monitor (SCM)

- **GigE Vision camera** for image capture (replace of Camera Link)
 - Develop camera control software to integrate in SPring-8 control framework

Details of development are described in this presentation

- **EtherCAT** for slow control
 - Motor control: screen operation, lens focusing, iris adjustment

→ See WEPHA068 M. Ishii, et. al,

"A Control System Using EtherCAT Technology for The Next-Generation Accelerator"



BPM & CT

- **MTCA.4** for readout electronics (replace of VME)
 - Use 10ch fast ADC module with FPGA firmware development

→ See TUAPP02 T. Fukui et. al,

"Development of the MTCA.4 I/O Cards for SPring-8 Upgrade and New 3 GeV Light Source"

GIGE VISION CAMERA CONTROL

SCM: Current camera system

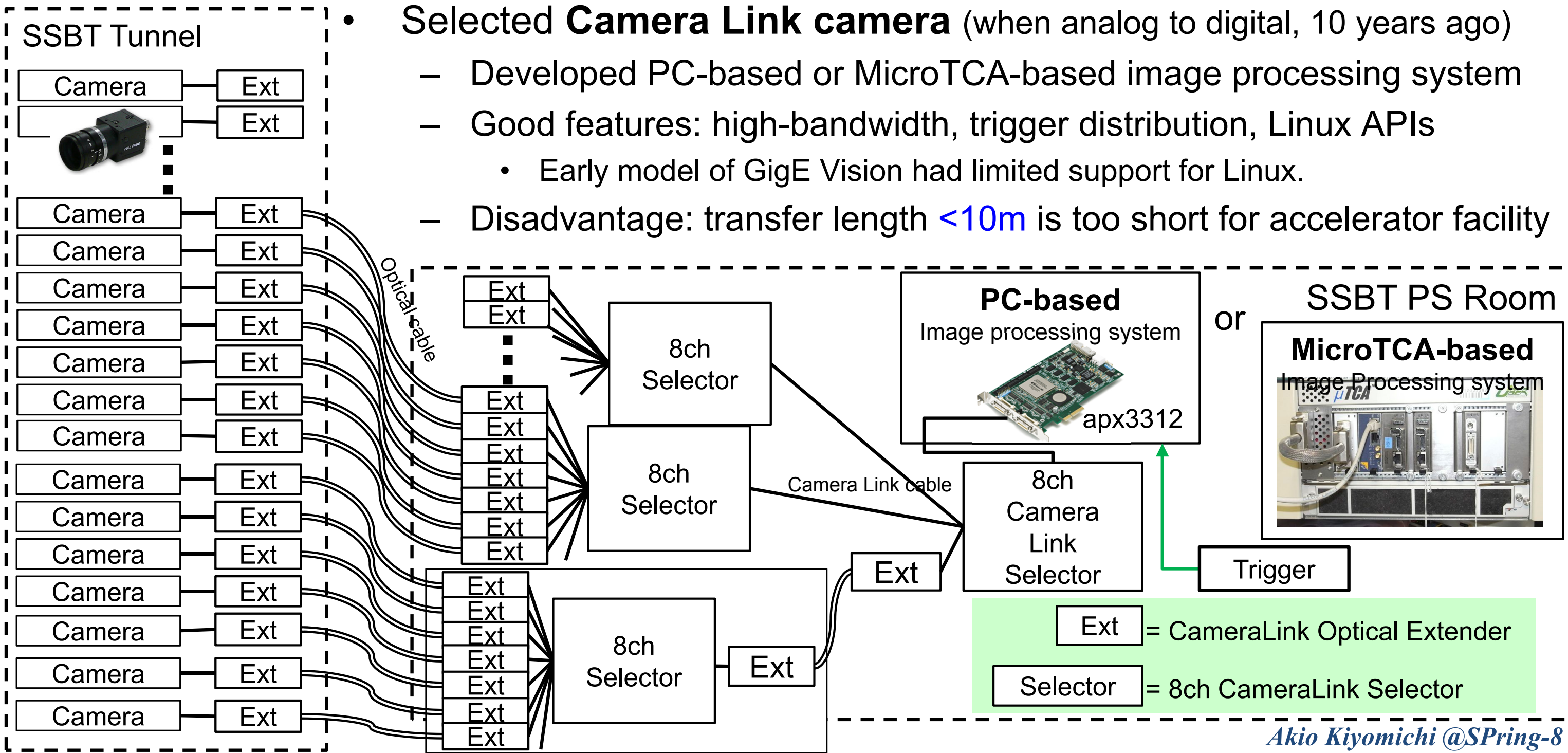

SCM: Current camera system

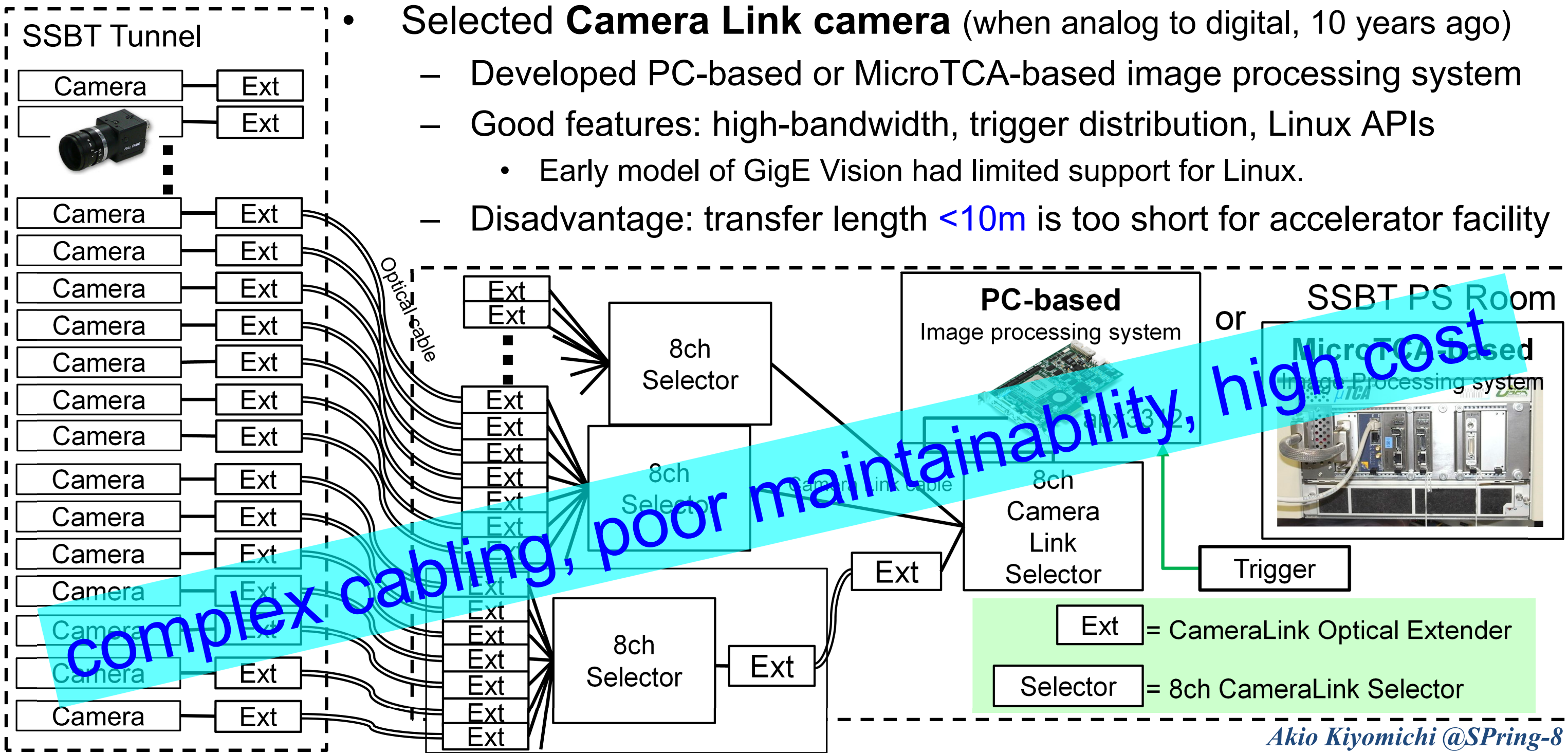

- Selected **Camera Link camera** (when analog to digital, 10 years ago)
 - Developed PC-based or MicroTCA-based image processing system
 - Good features: high-bandwidth, trigger distribution, Linux APIs
 - Early model of GigE Vision had limited support for Linux.
 - Disadvantage: transfer length $<10m$ is too short for accelerator facility

complex cabling, poor maintainability, high cost

Ext = CameraLink Optical Extender

Selector = 8ch CameraLink Selector

SCM: New camera system

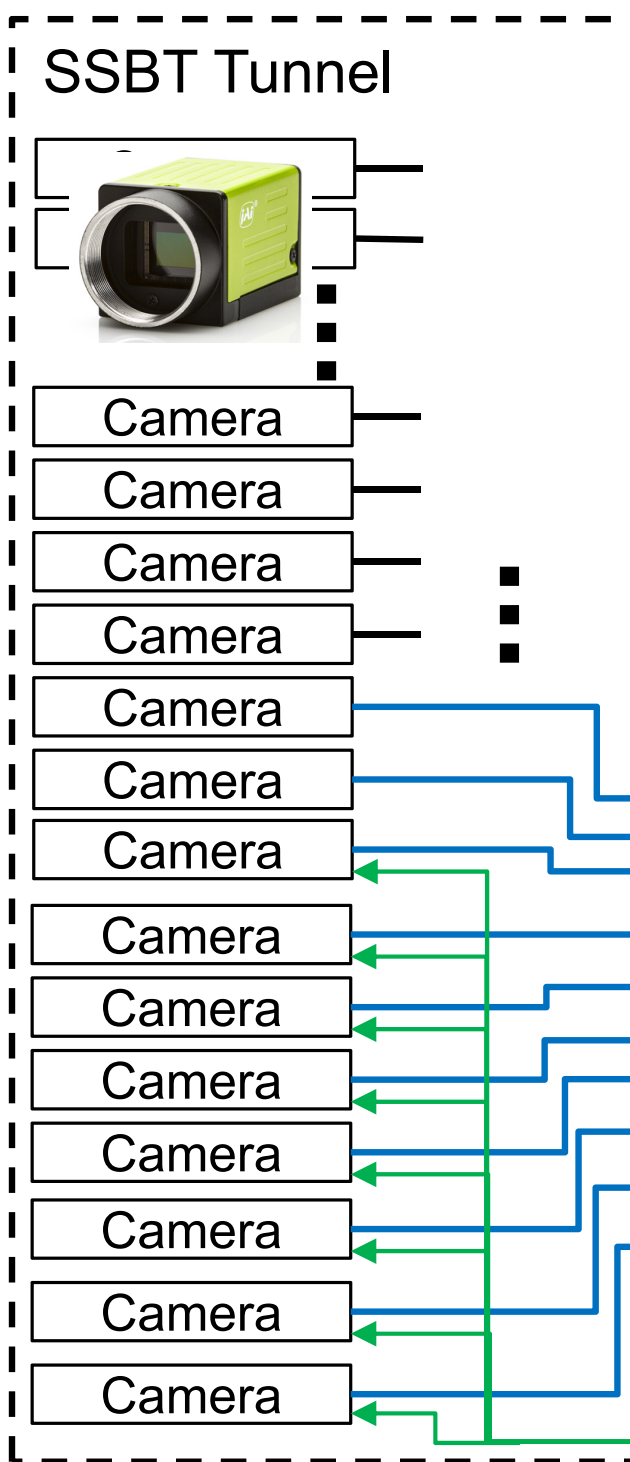

- Adopt **GigE Vision Camera**
 - Long transfer length <100m, use standard Ethernet cable
 - Power supply and power control using PoE type Ethernet board
 - **simple cabling, good maintainability, low cost**
 - Software: There is open source library.

Future plan: GigE camera connection

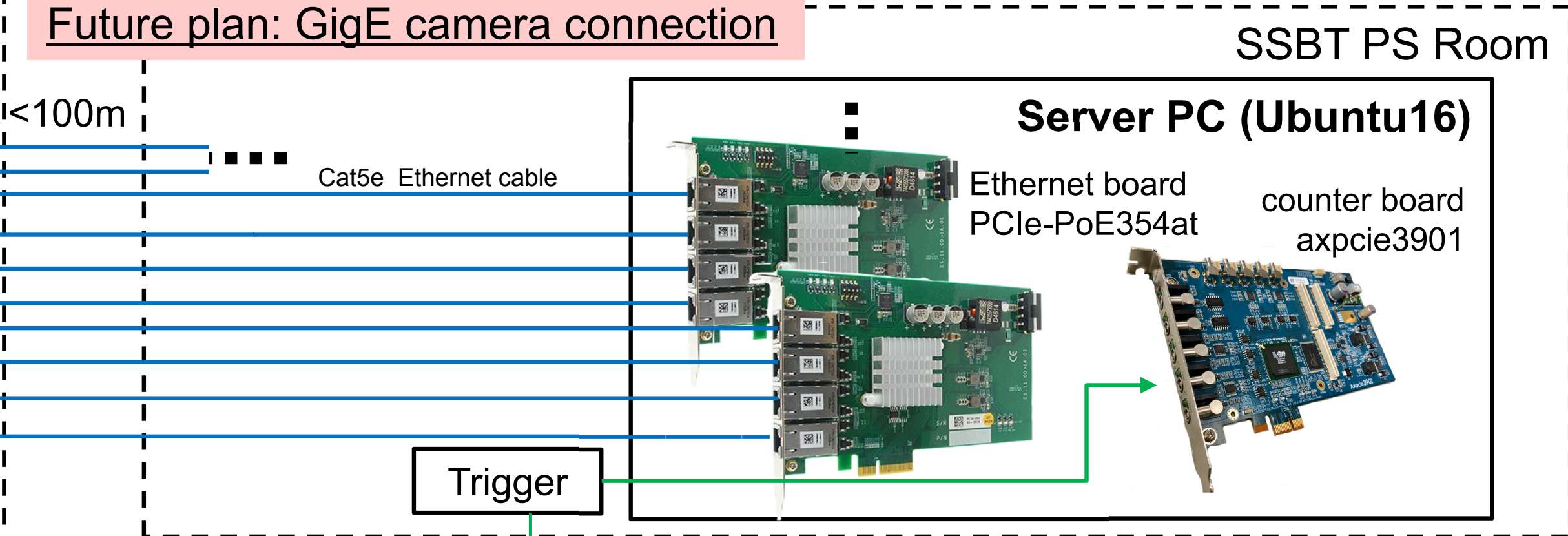

GigE Vision Camera Control

- Use general-purpose open source library for Linux : **Aravis**
<http://www.github.com/AravisProject/aravis>
 - glib/gobject based library for video acquisition
 - camera control (gain, exposure, ROI, ...), image acquisition, viewer
 - The specific functions (IP address setting, ...) are not supported. We use vendors' software only once installing the camera.
- Develop camera control software using Aravis library
 - OS: Ubuntu16.04 LTS 64-bit server, lowlatency kernel
 - Aravis version: 0.6
 - **Integrate various vendors GigE Vision cameras with the SPring-8 control framework.**
 - Provide basic camera control functions, image data acquisition



GigE Vision Camera Control

- Device setup
 - PoE type Ethernet board: Neousys tech. PCIe-PoE254at
 - Realize power control using vendor provided library
 - Remote control of camera power is possible
 - Trigger counter board: Gopher axpcie3901
 - 4ch 32bit counter, TTL or NIM, up to 200MHz
- Image data acquisition
 - Use MDAQ (SPring-8 DAQ scheme) synchronized with beam trigger
 - See WECPL01 T. Sugimoto et. al, "Status of the Control System for Fully Integrated SACLA/SPring-8 Accelerator Complex and New 3 GeV Light Source Being Constructed at Tohoku, Japan"
 - Grabbed image data is stored in file server with HDF5 format



PCIe-PoE354at

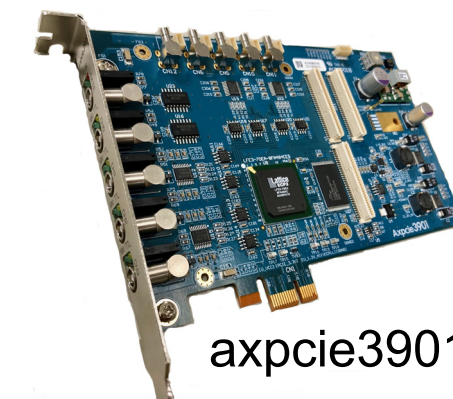

axpcie3901

Image Data Format

- Data format: HDF5 (Hierarchical Data Format version5)
 - Image data and properties are stored in one HDF5 file
 - The properties (timestamp, event no., gain, etc...) will store into database in future.

Group	/RunInfo
Dataset	/CameraImage <i>2D array, 16bit unsigned int</i>
Attribute	run_id (int) timestamp (double) sec (int) usec (int) seq_no (int) evno (int) flag (int) gain (int) shutter_speed (int) threshold (int) data_size(int)

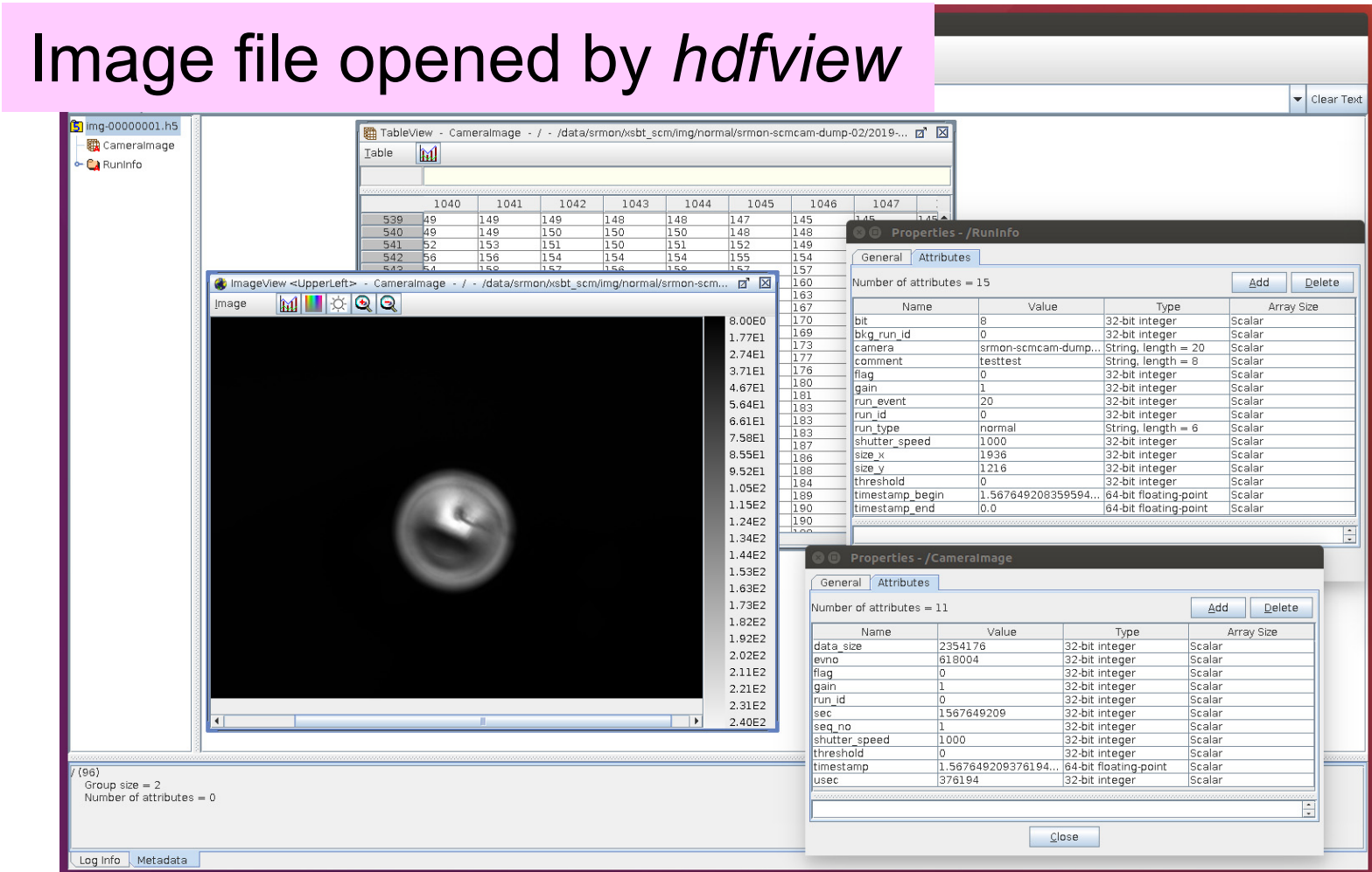

BEAM TEST OF CAMERA SYSTEM

Beam Test of Camera System

- In September 2019, two SCMs installed in Sy dump line.
 - To test the Ce:YAG screen and GigE Vision camera.
 - Prior to the monitor upgrade project

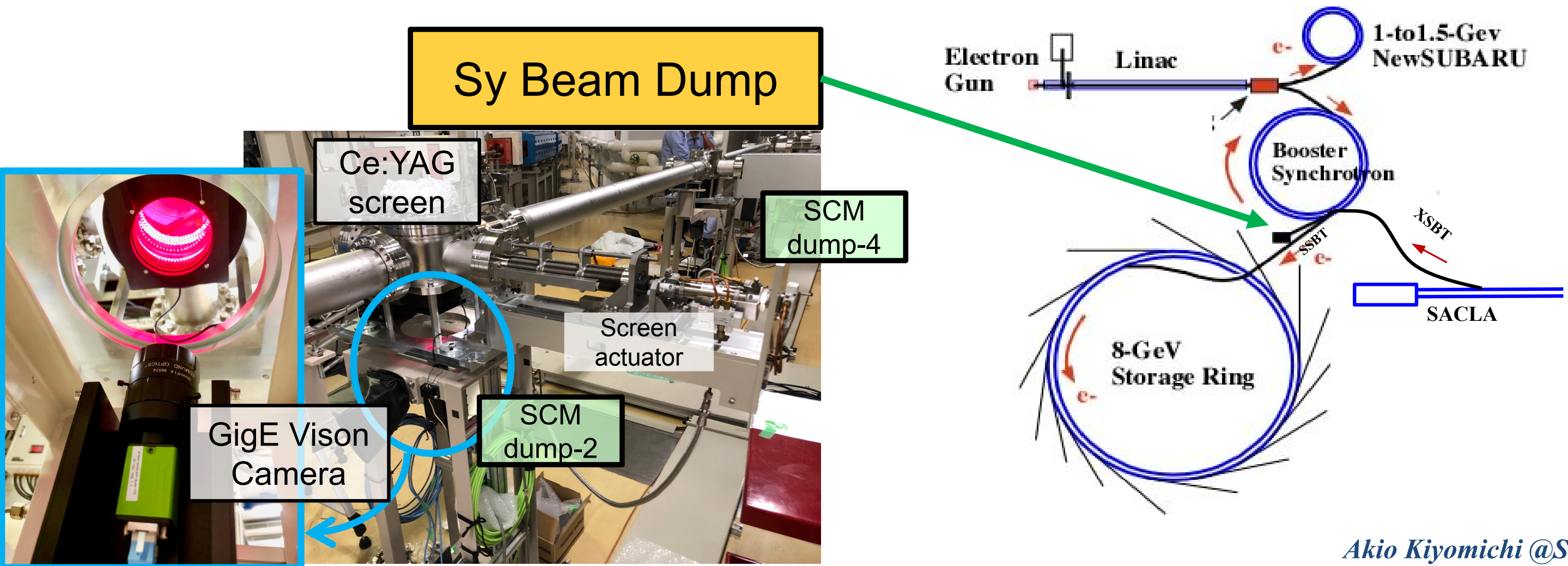

Beam Test of Camera System

- In September 2019, two SCMs installed in Sy dump line.
 - To test the Ce:YAG screen and GigE Vision camera.
- Built PC-based GigE Vision camera image processing system
 - Camera control, image acquisition synchronized with beam trigger

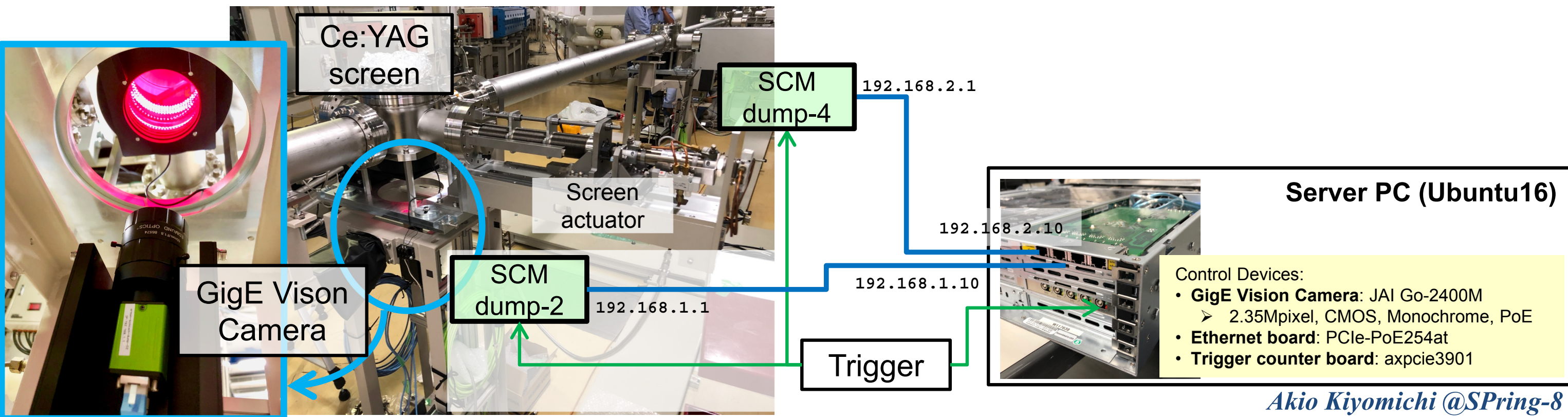

Beam Test of Camera System

- In September 2019, two SCMs installed in Sy dump line.
 - To test the Ce:YAG screen and GigE Vision camera.
- Built PC-based GigE Vision camera image processing system
 - Camera control, image acquisition synchronized with beam trigger
 - Grabbed image data is stored in file server and viewed by GUI.

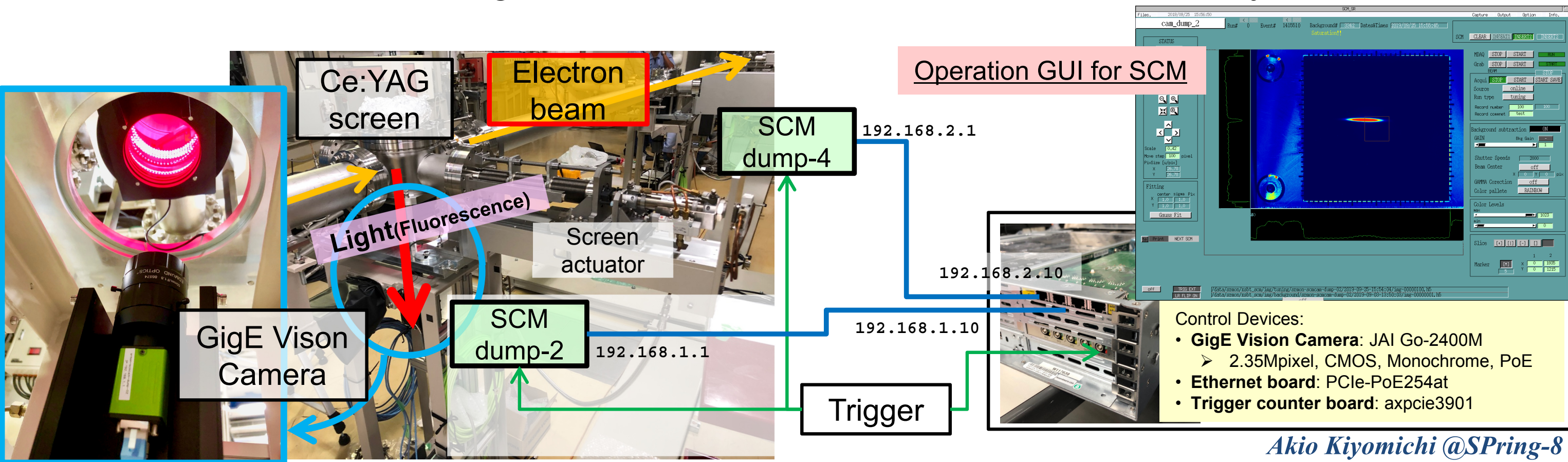

Beam Test of Camera System

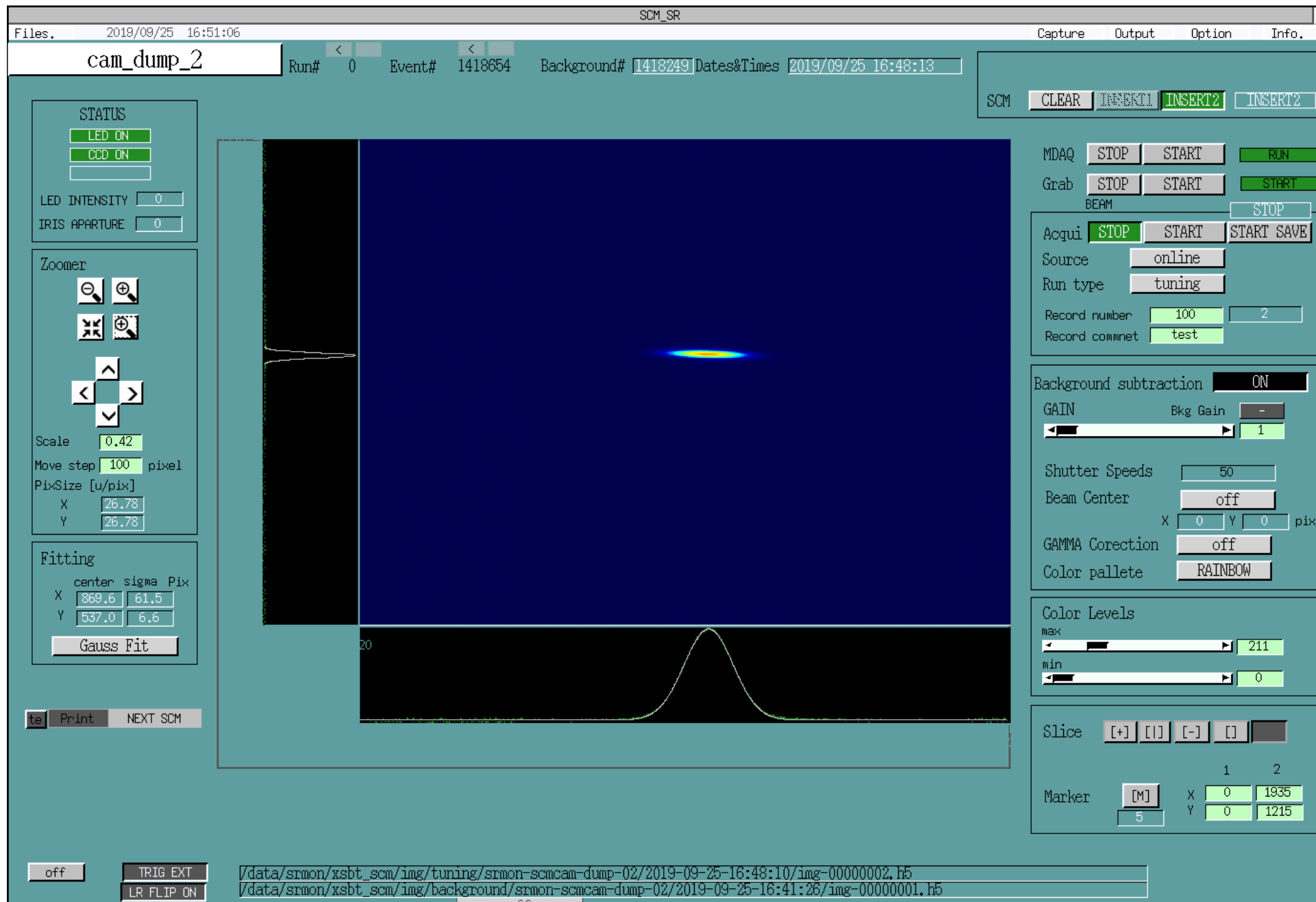

- GUI performs with Sy beam injection.
 - Camera control
 - Image record
 - BG suppression and image analysis
- SACLA injection will test with optics tuning

Beam Test of Camera System

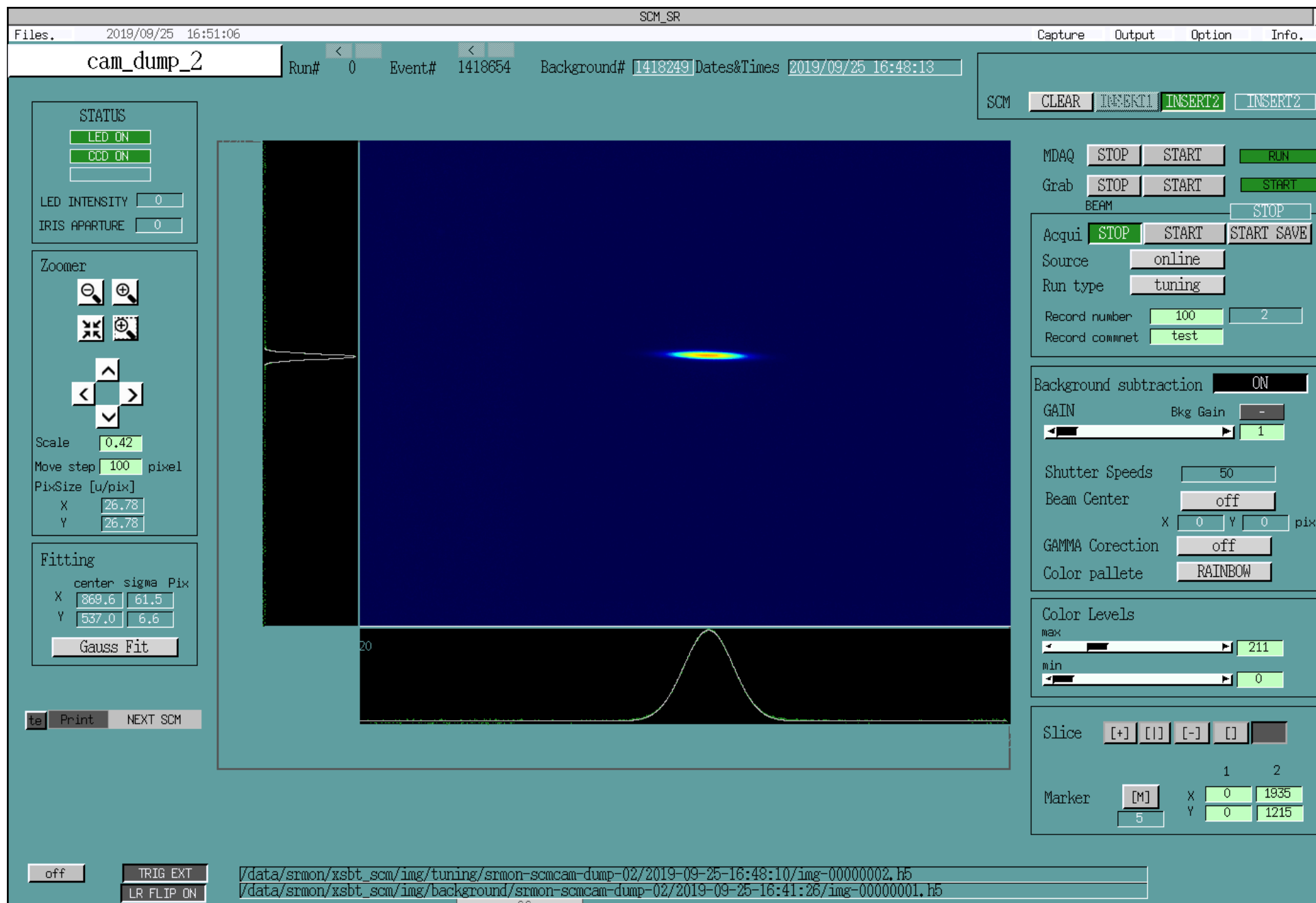

- GUI performs with Sy beam injection.
 - Camera control
 - Image record
 - BG suppression and image analysis

- SACLA injection will test with optics tuning

Camera control system is ready for beam injection

Summary

- We are constructing control system of beam monitor, for beam injection from SACLA to SPring-8.
- GigE Vision camera image processing system were developed.
 - Use open source library, Aravis.
 - Integrate various vendors' cameras with SPring-8 control framework.
 - Realize camera control, image acquisition synchronized with beam trigger
- We built the control system of SCM using GigE Vision camera and performed with beam operation.