

# Short pulses and 2-color capabilities at the SASE3 FEL line of the European XFEL



Svitozar Serkez (European XFEL)

*on behalf of our R&D team, SCS, SQS, XPD, MXL, RCs, PRCs*



## SASE3 split undulator 2-color setup

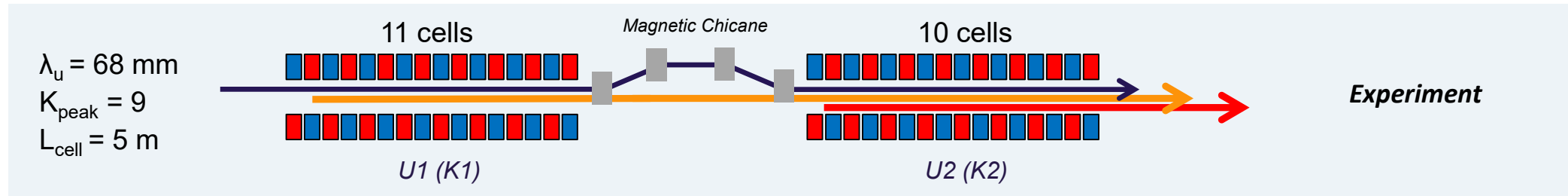

- One undulator cell replaced with a magnetic chicane
  - Consists of four 60cm-long dipoles with max field of 1.2T
  - Funded by the Academy of Finland with co-funding by the European XFEL
  
- Chronology:
  - 15.05.2019 First 2-color lasing without pulse delay
  - 03.08.2020 Chicane commissioning
  - 10.10.2020 2 colors with picosecond- & negative delays at EuXFEL
  - 21.10.2021 First femtosecond-order pump-probe generation



## 2-color delivery parameters:

- Experimentally achieved equalized pulse energies (depend on electron energy):

2.2 keV: 2 x 150  $\mu$ J

1.6 keV: 2 x 200  $\mu$ J

1.2 keV: 2 x 300  $\mu$ J

1.0 keV: 2 x 700  $\mu$ J

0.8 keV: 2 x 800  $\mu$ J

0.6 keV: 2 x 900  $\mu$ J

*NB: total energy may be much higher if U1 emits little power, e.g. 1 $\mu$ J@930eV + 3mJ@945eV*

### Undulator resonance range

Electron Energy [GeV]	Minimum Photon Energy [eV]	Maximum Photon Energy [eV]
8.5	240	1080
12	480	2160
14	650	2930
17.5	1020	3000

### Maximum chicane delay range

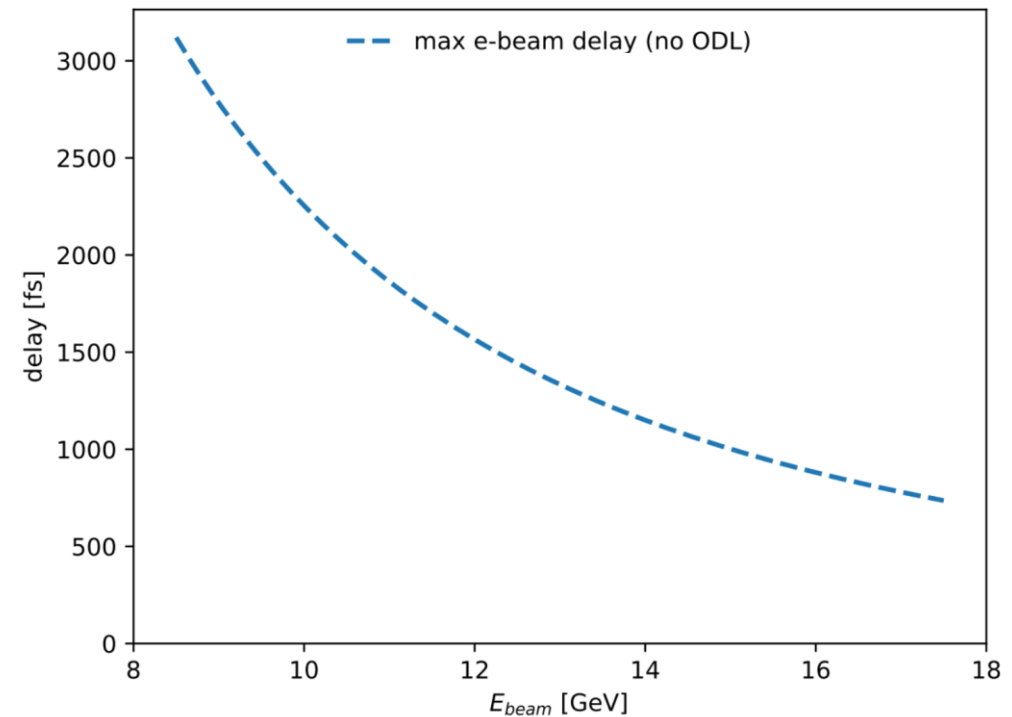

# Two sources in the undulator

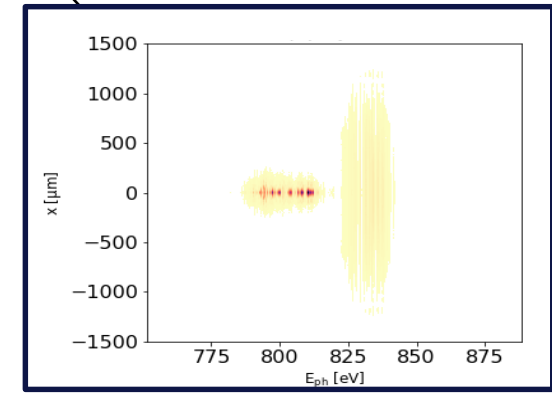
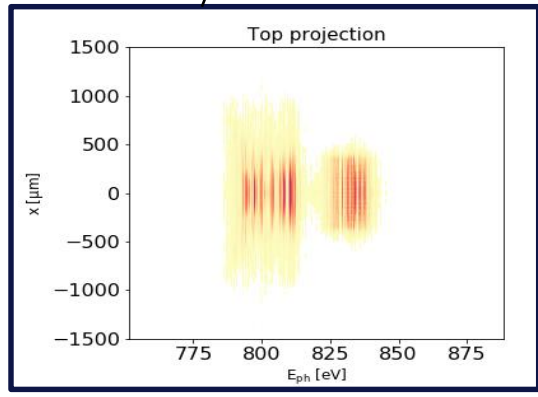
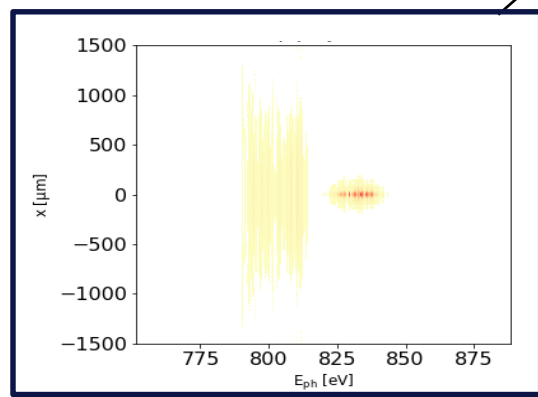
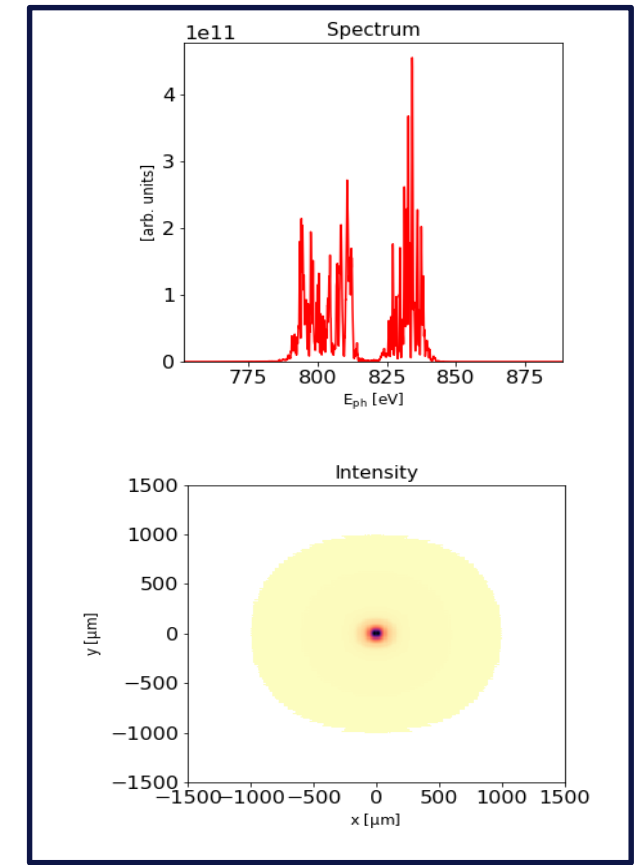
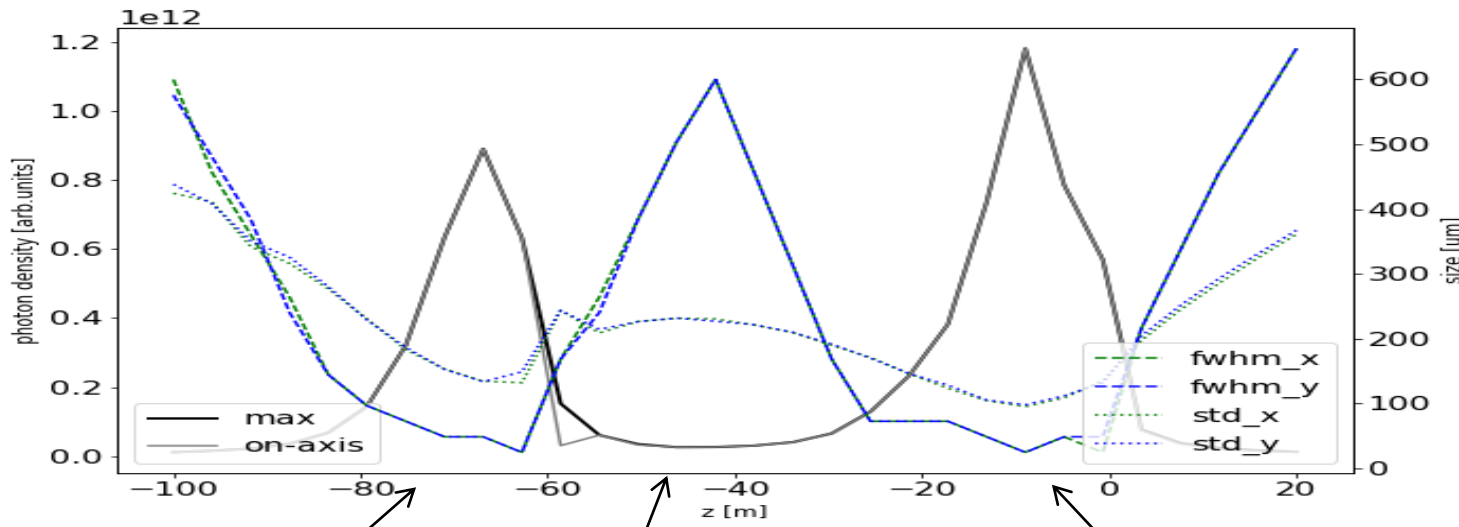
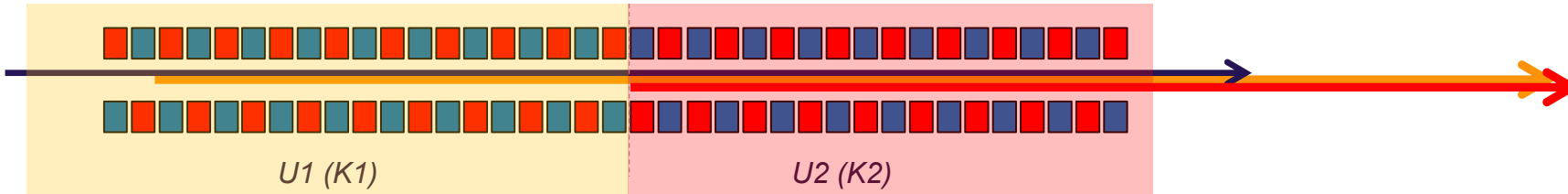

- Results of numerical backpropagation
- Two distinct sources of different photon energies separated by approx. 60m

# Two sources = Two images at the sample

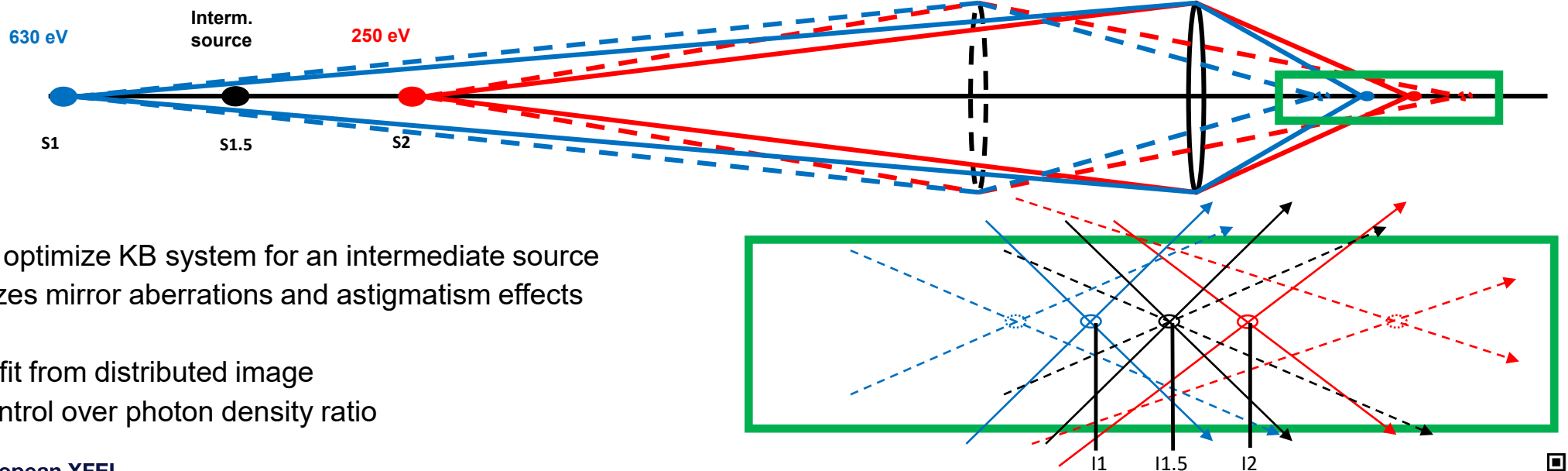
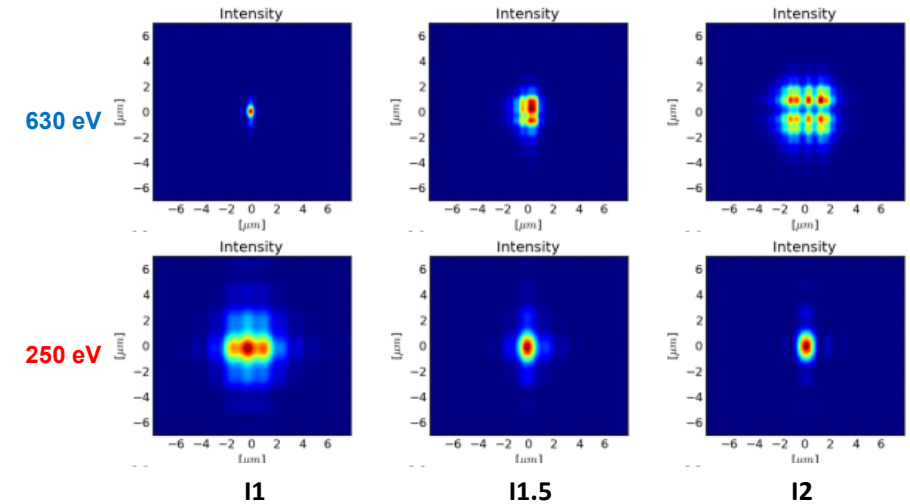
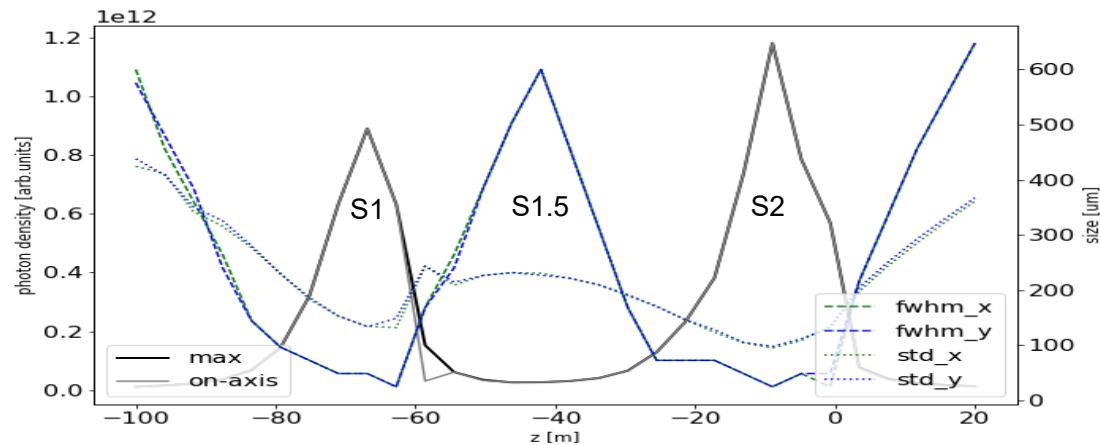

- It is beneficial to optimize KB system for an intermediate source
- This minimizes mirror aberrations and astigmatism effects
- Users may benefit from distributed image
- Provides control over photon density ratio



## 2-color diagnostics

- SASE3 Spectrometer (Plane grating - based)
  - Invasive
  - Provides limited photon energy window (e.g. ~50eV window @ 900eV)
  - 2<sup>nd</sup>, 3<sup>rd</sup> orders yield better resolution
  - Online analysis with pySpectrometer
  - 10 Hz acquisition (1 bunch per train)
  - Used for 2-color set-up
  
- Photo Electron Spectrometer
  - Non-invasive
  - Independent retardation voltage control per quadrant -> 2 independent energy windows
  - Lower resolution, non-linear over photon energy range
    - ▶ Usable bandwidth and integral under the spectra
  - Good correlation of integrated spectrum with XGM
    - ▶ viable alternative to XGM upon cross-calibration
  - 4.5 MHz full train acquisition
  - Used in parallel with user's data-acquisition

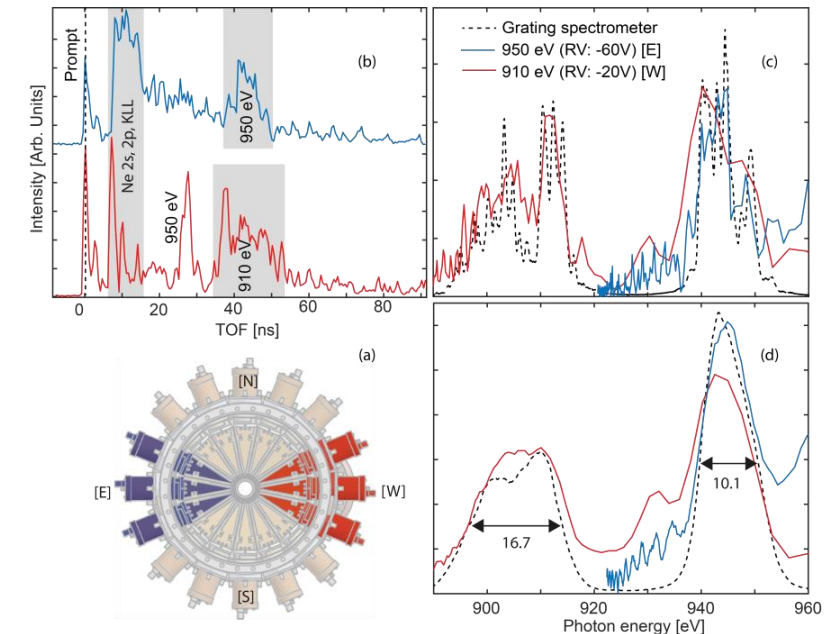
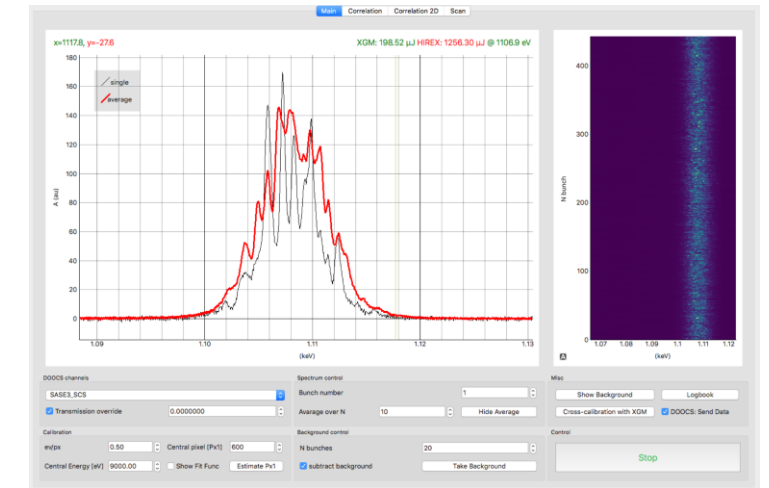
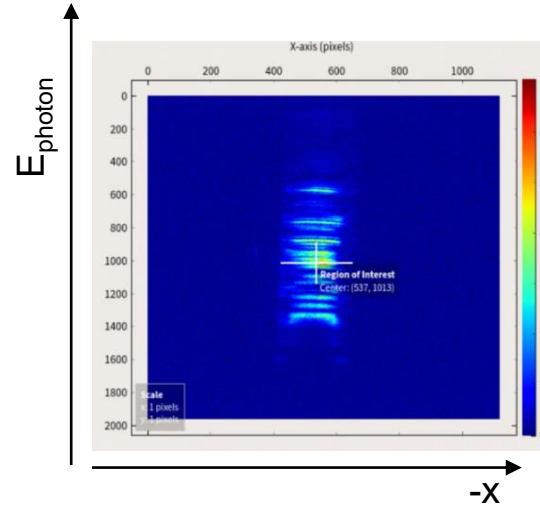

## Stability and tuning of the colors

- Both colors are stable in pulse- and photon energy
  - Shot-to-shot pulse energy correlation is insignificant
- Changing properties of the pump (e.g. pulse- or photon energy) affects properties of the probe
  - Users often ask us to switch off each
- If photon energies are close or harmonic of each other delay scan may show cross-talk between the colors

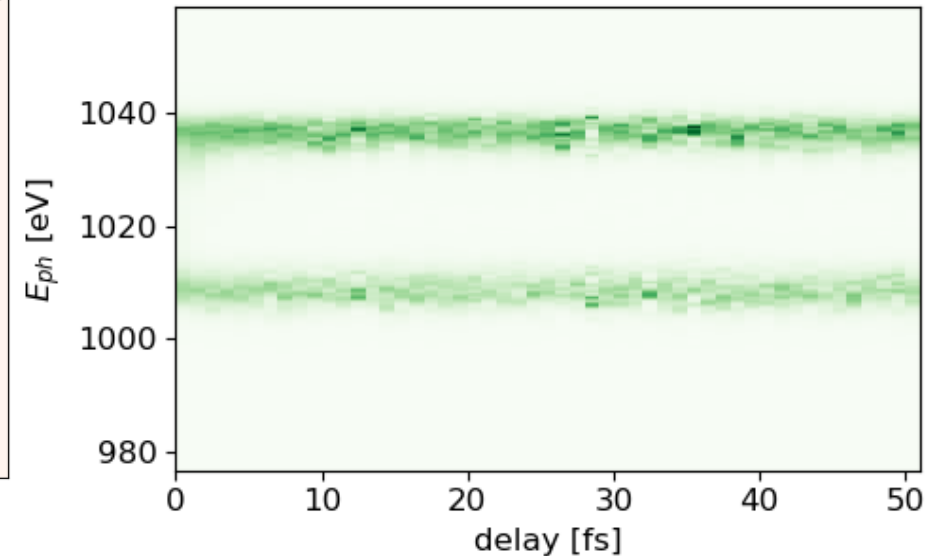
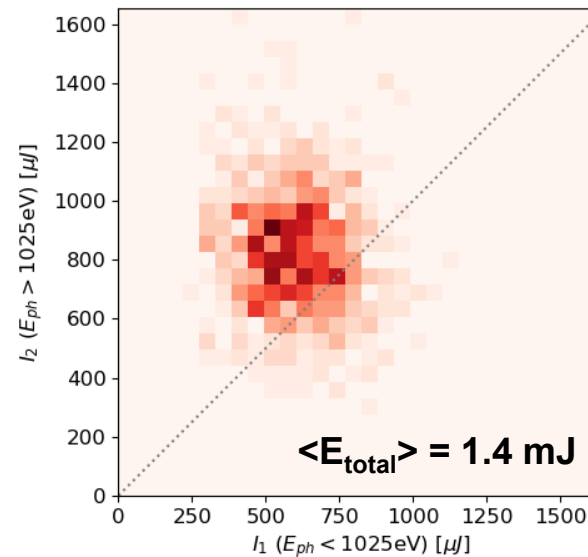
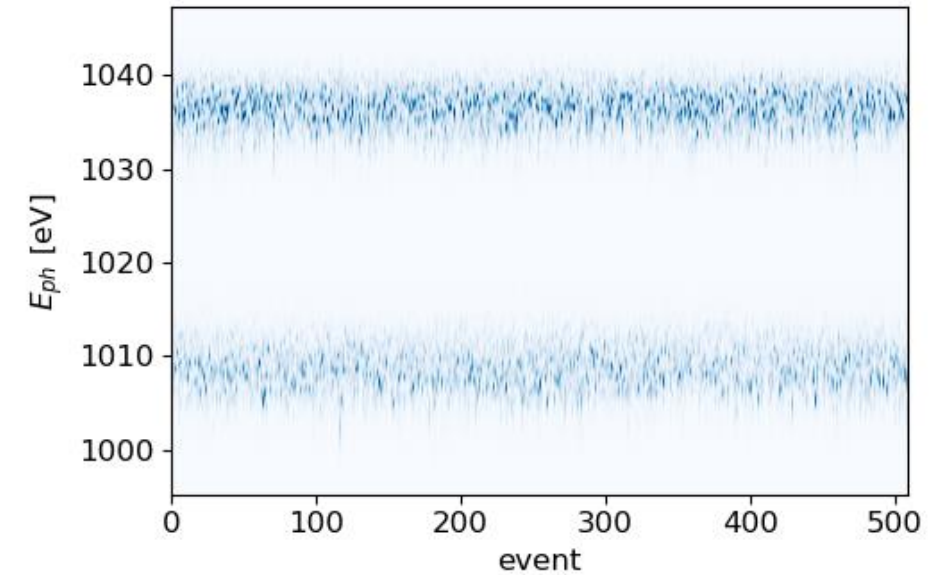
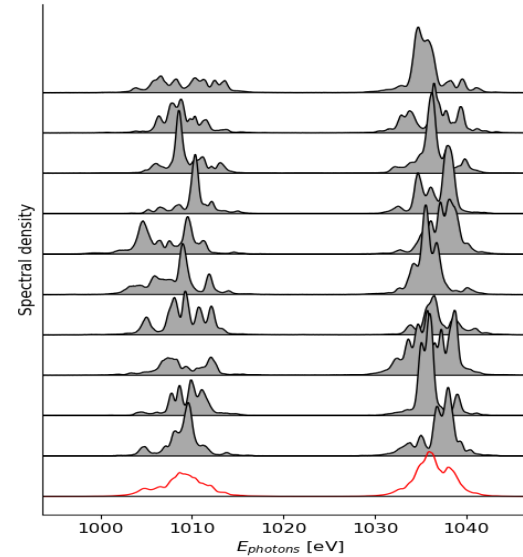

## Stability and tuning of the colors

- Both colors are stable in pulse- and photon energy
  - Shot-to-shot pulse energy correlation is insignificant
- Changing properties of the pump (e.g. pulse- or photon energy) affects properties of the probe
  - Users often ask us to switch off each
- If photon energies are close or harmonic of each other delay scan may show cross-talk between the colors
- Users also ask for a negative delay

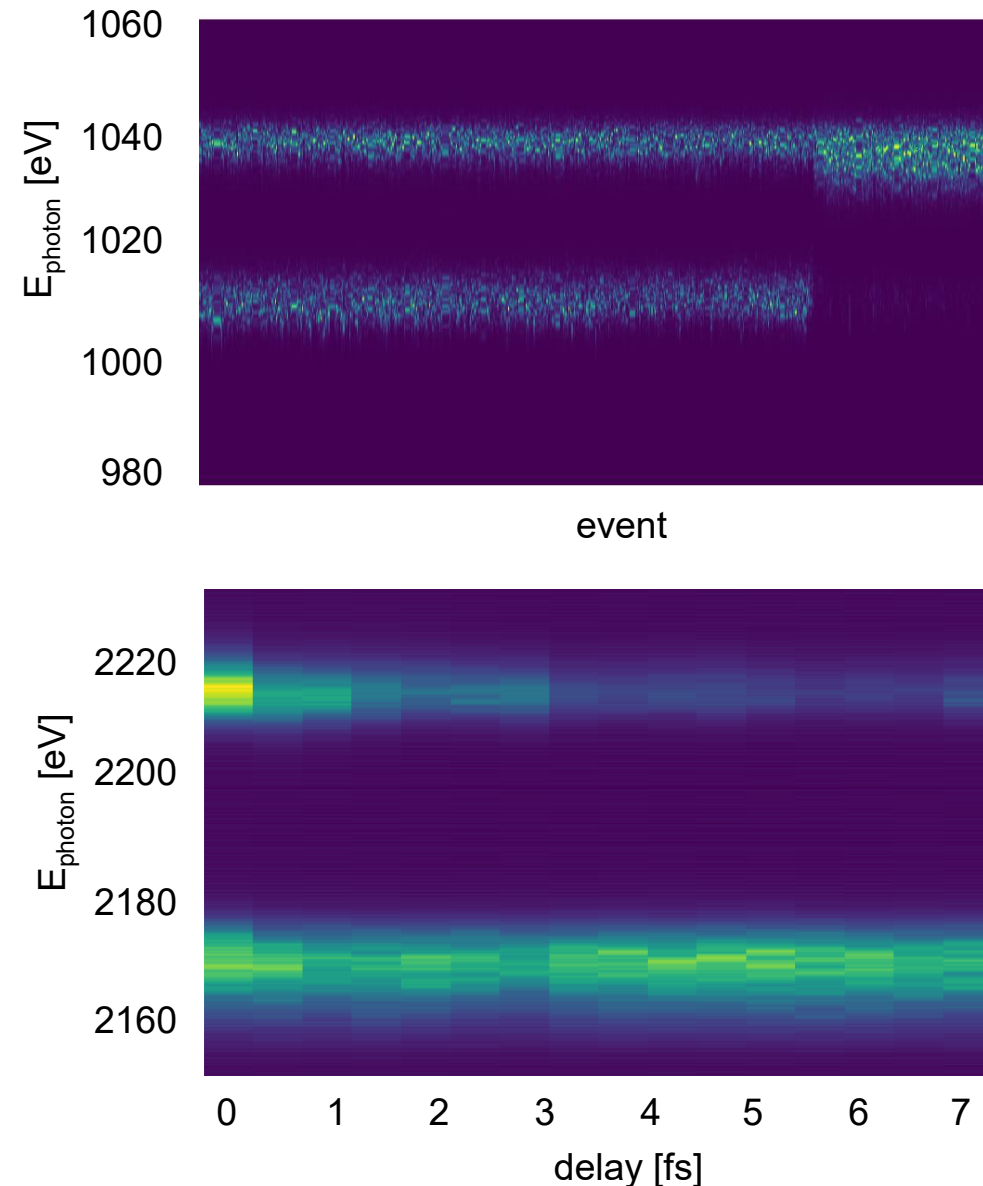

# Chicane including optical delay line (ODL)

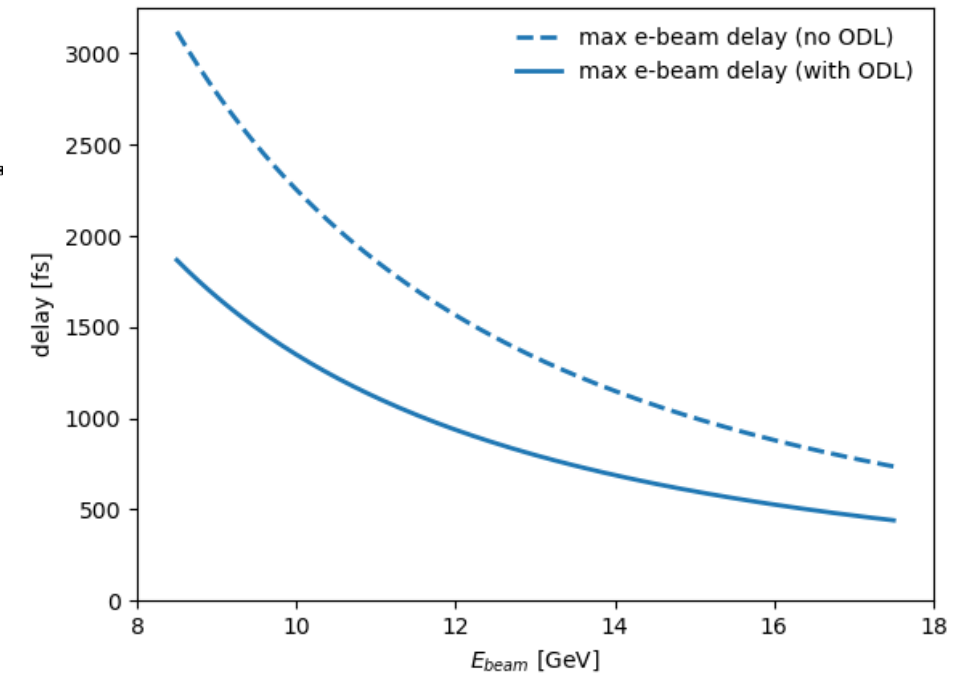
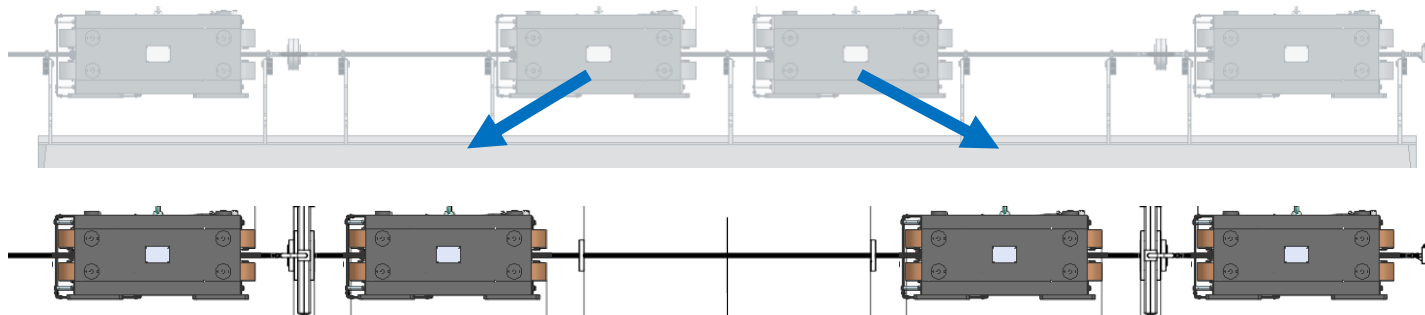
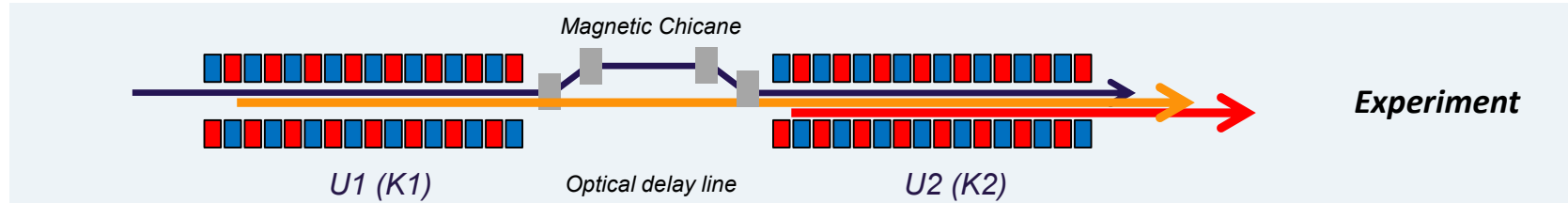

# Chicane including optical delay line (ODL)

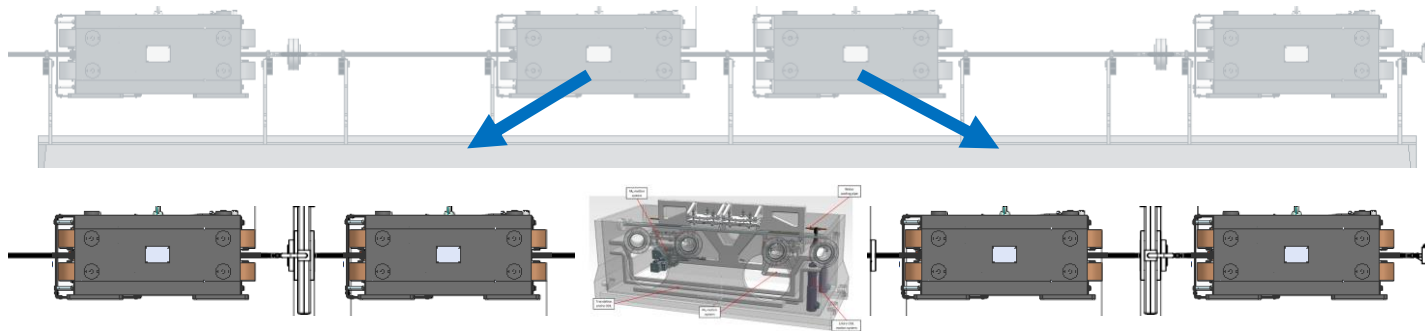
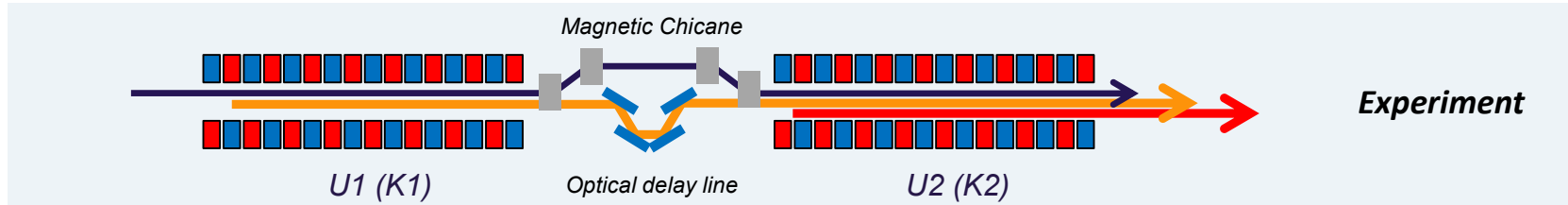

Parameter	Value
Mirror length L	140 mm
Mirror clear aperture	130 mm
Distance (M1 to M2) $d_{12}$	185 mm
Incidence grazing angle $\alpha$	9 mrad
Radiation offset g	3.33 mm
Optical delay	-200 fs
Coating	B4C

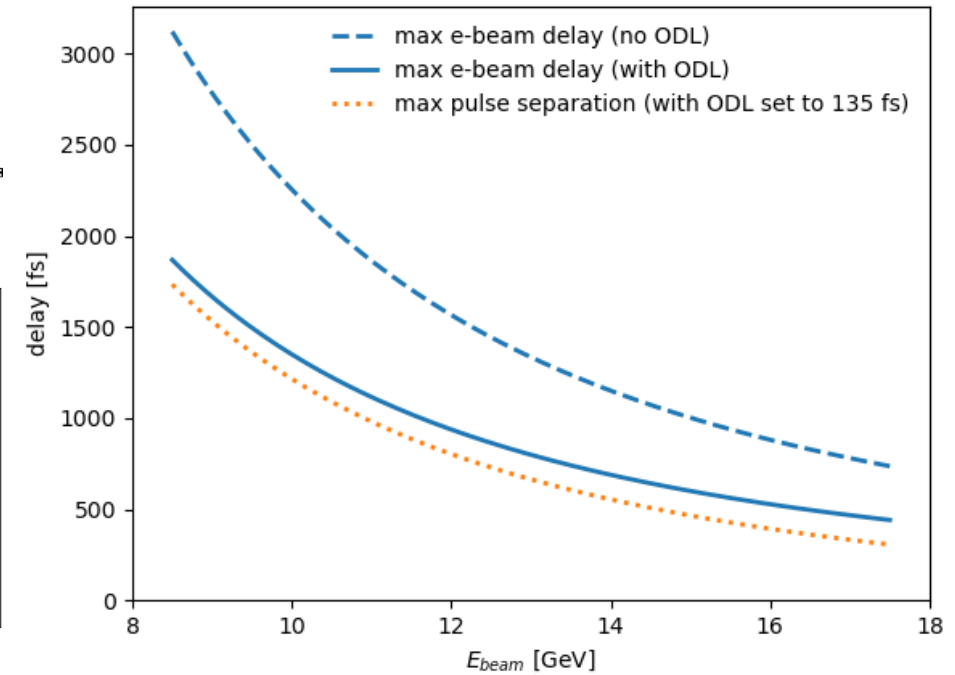
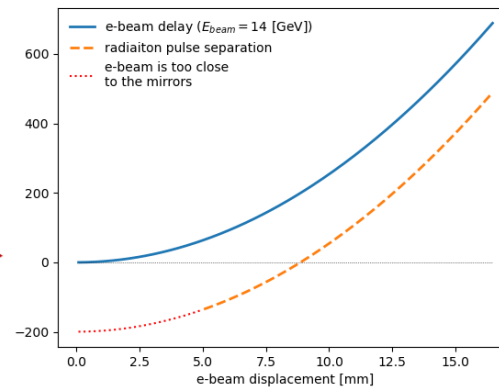
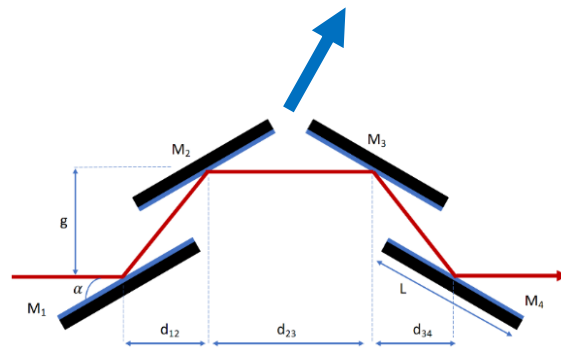

# ODL single-shot damage and heat-load estimations

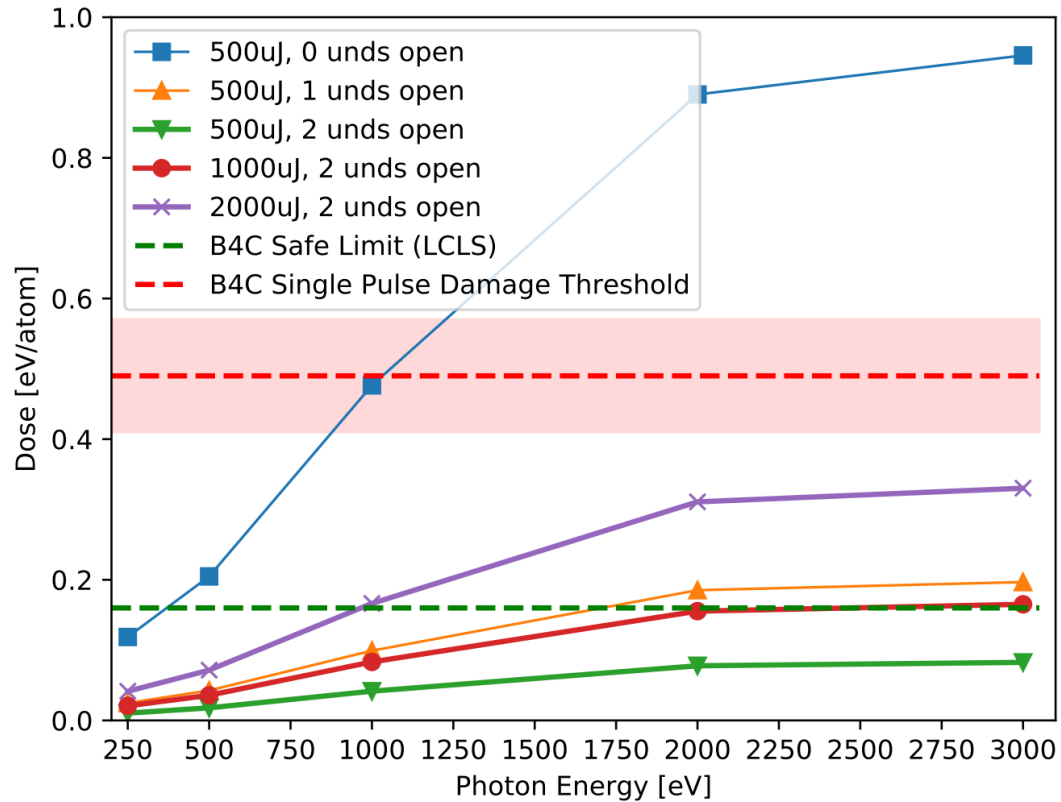

- Single-shot damage is caused by narrow-bandwidth SASE radiation at undulator's fundamental harmonic, absorbed within few nanometers below the mirrors surface

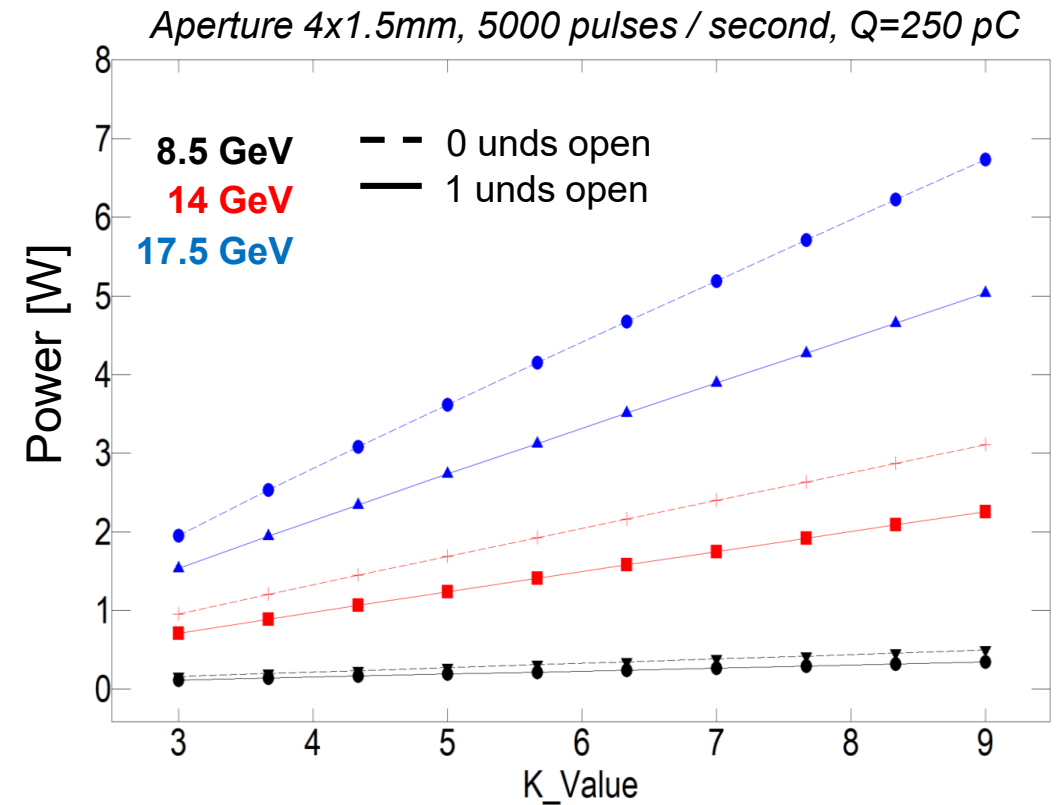

- Mirrors are heated by high-intensity high-photon-energy spontaneous radiation of higher undulator harmonics, penetrating deep into the mirror



## **E-beam chirps and their diagnostics**

# Electron beam longitudinal phase-space control, diagnostics and speculations

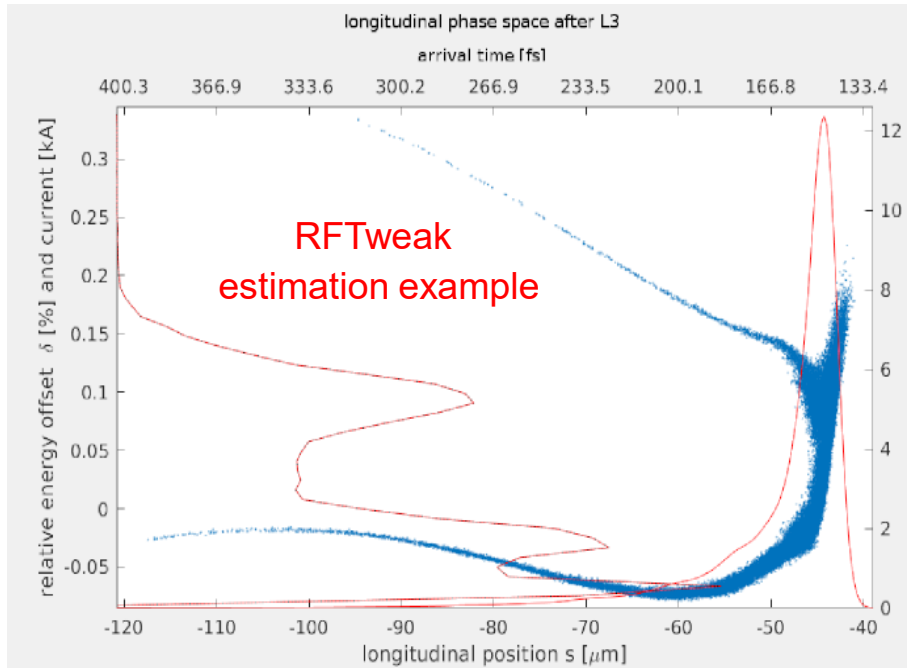

- We lack direct diagnostics of e-beam longitudinal phase space next to SASE3 undulator
- Can make qualitative estimations based on control room tool RFTweak and some s2e simulations
- Non-linear compression and self-effects result in strong chirp at the entrance to SASE3 undulator
- We can vary compression per beamline (see [MOP36](#) by M.Guetg)

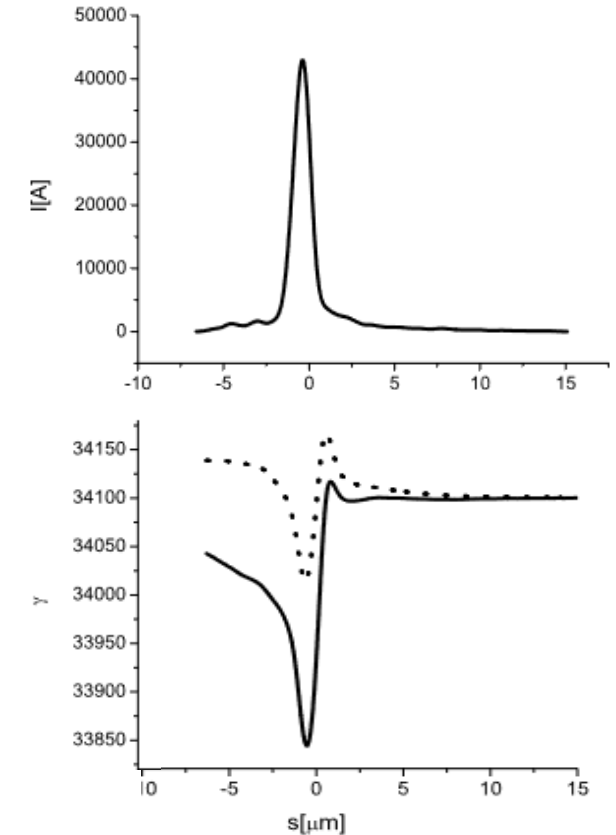

# Nonlinear e-beam compression creates ~2% non-linear energy chirp

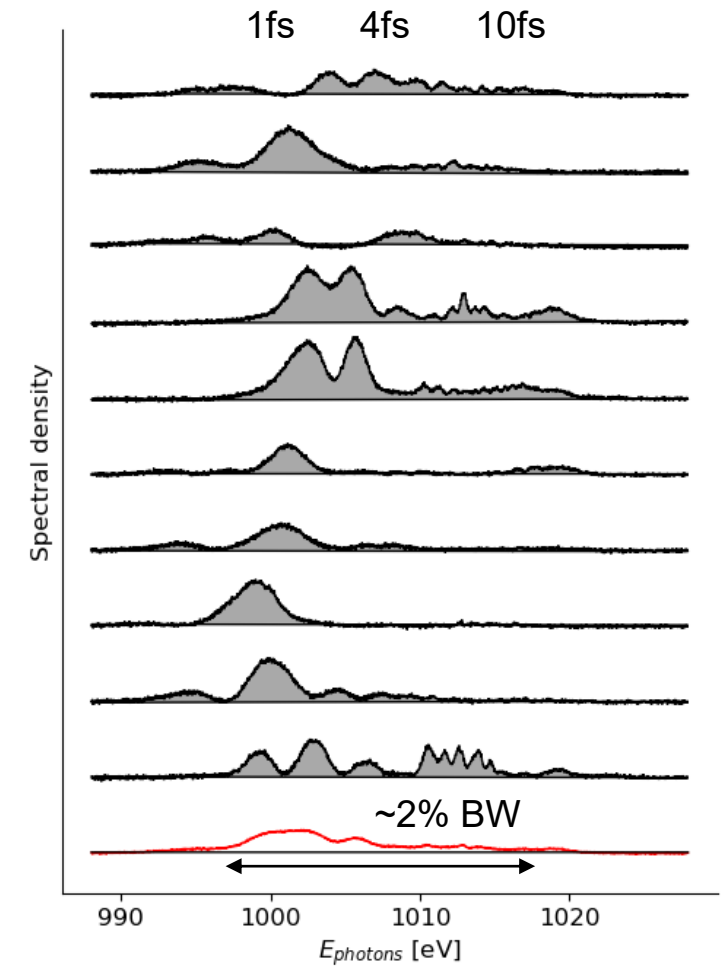
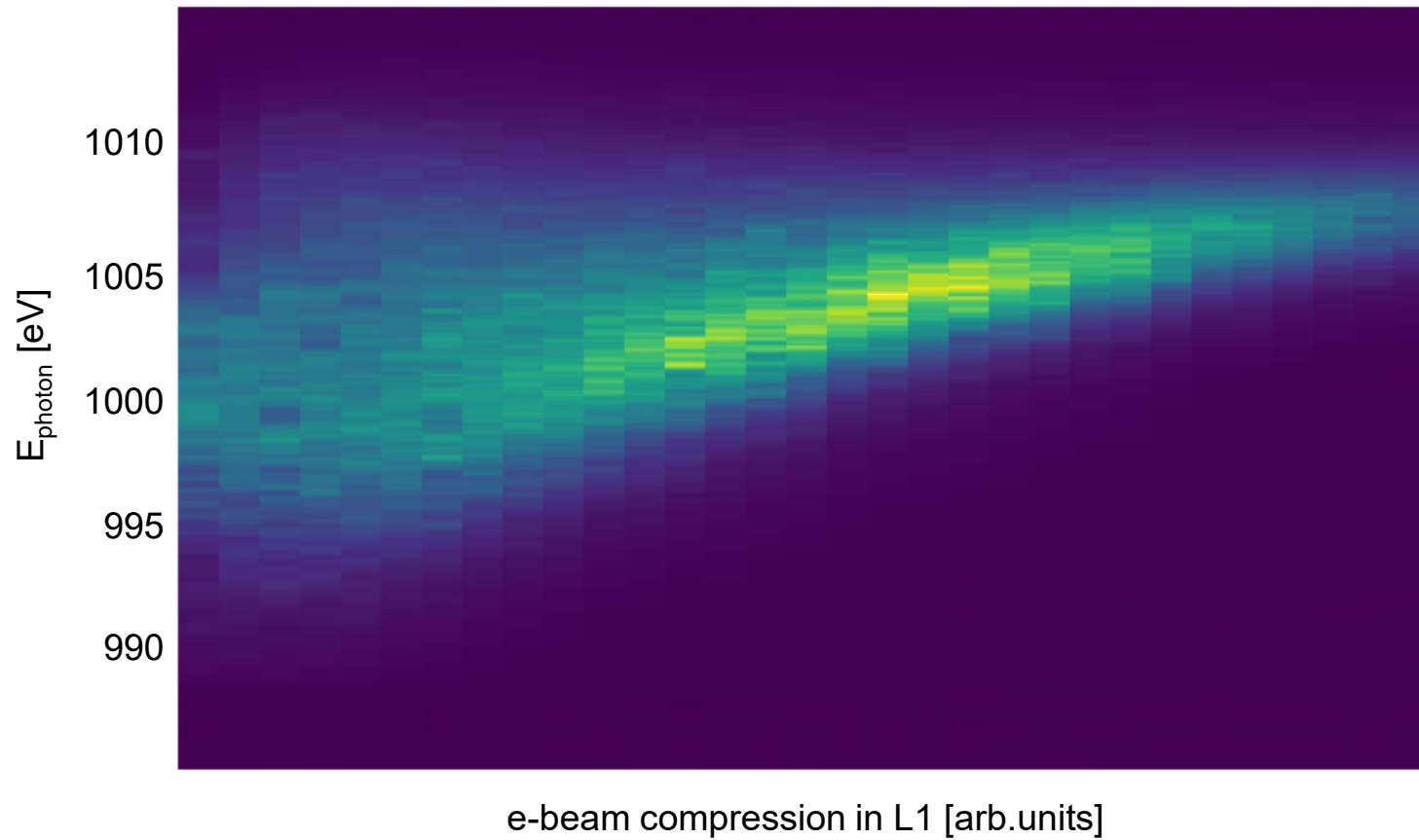

# Diagnosing quadratic energy chirp based on spectrum (ROSA)

Measurement -> ROSA analysis

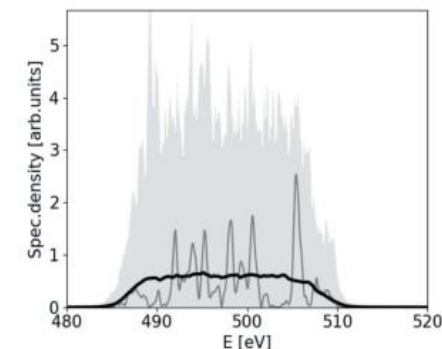
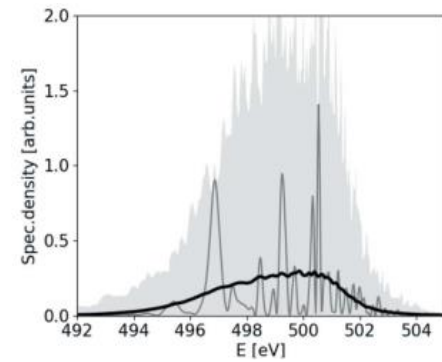
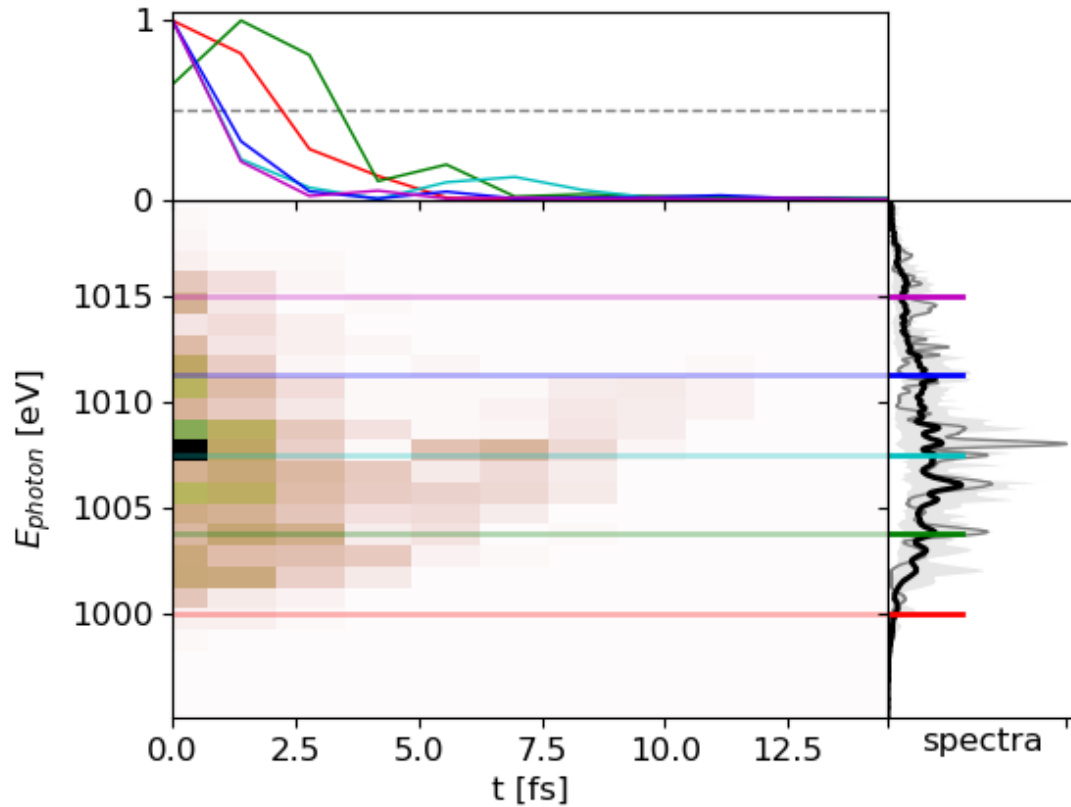

Older numerical simulations

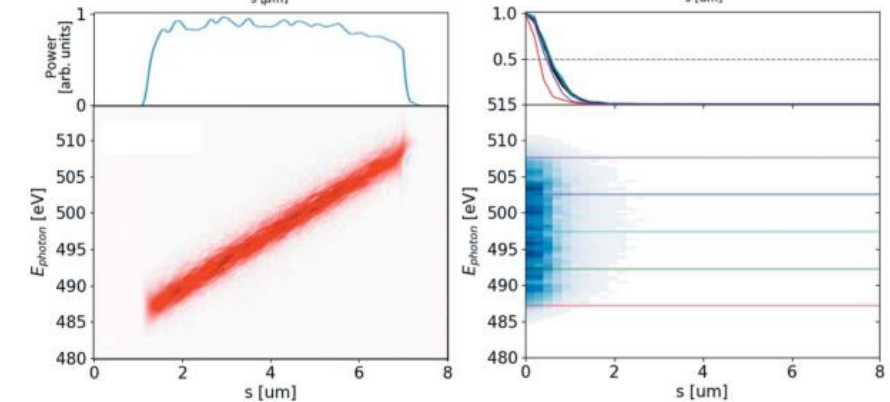
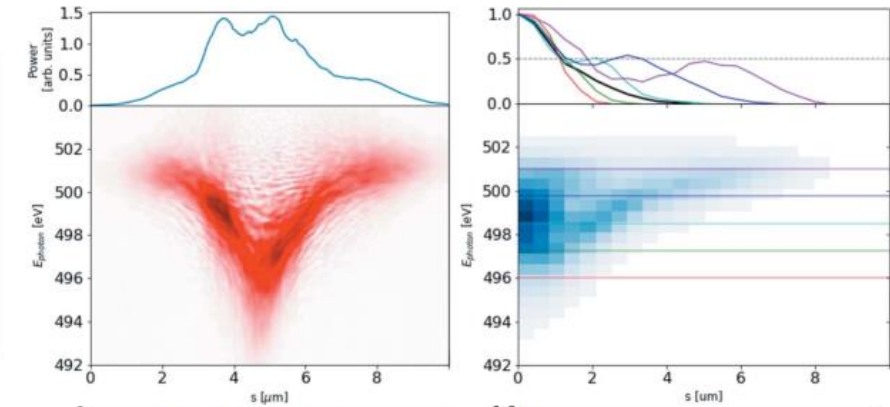

# We can measure the [linear component of] e-beam energy chirp

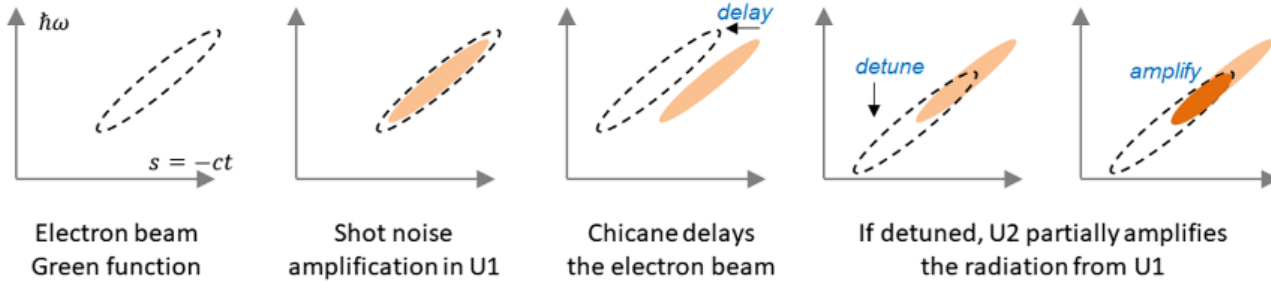
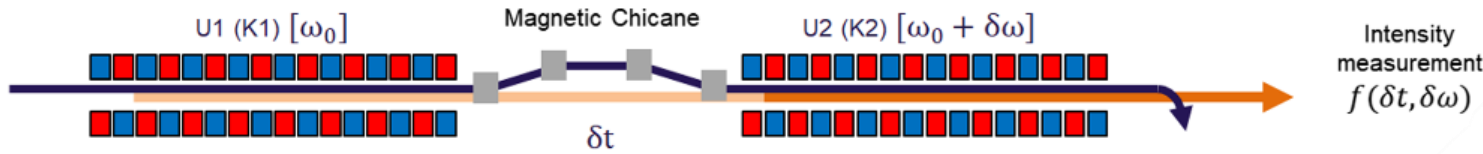

- Chicane + variable gap undulator  
-> autocorrelate time-frequency phase space
- Obtain chirp sign and value
- Works best in hard X-ray range
- Needs smeared-out microbunching

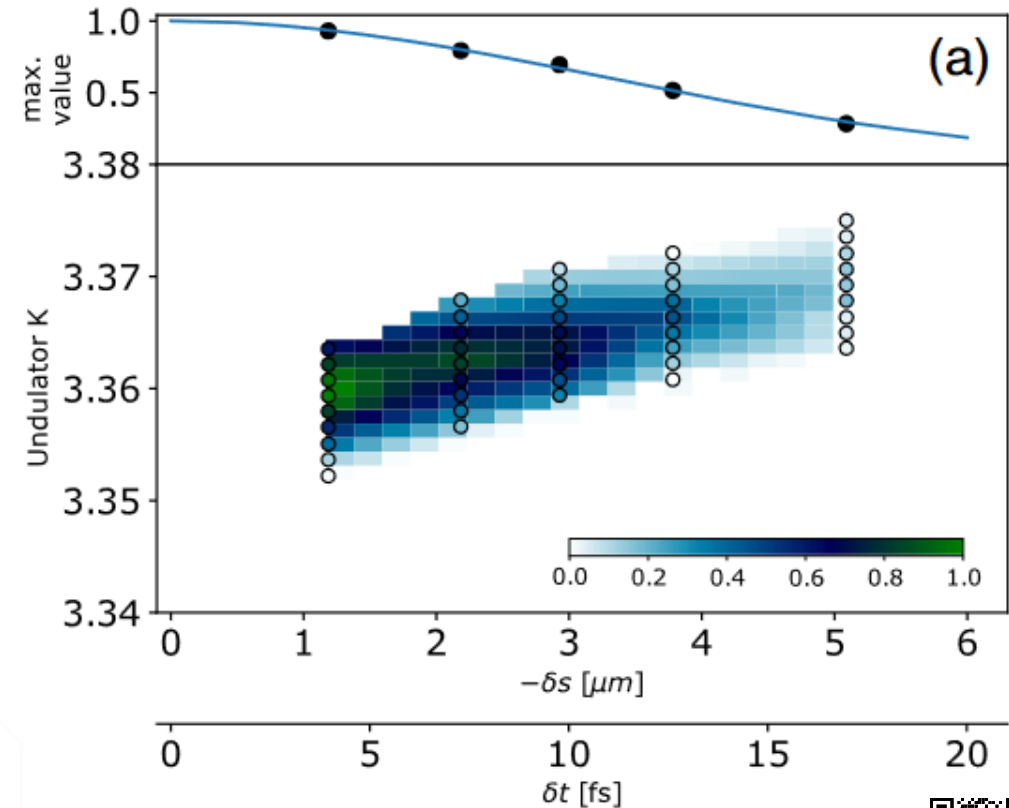

## **Dispersion-based fresh-slice 2-colors:**

**Increasing e-beam chirp and beamline transverse dispersion**

## Increasing beam compression caused bifurcation of the second color

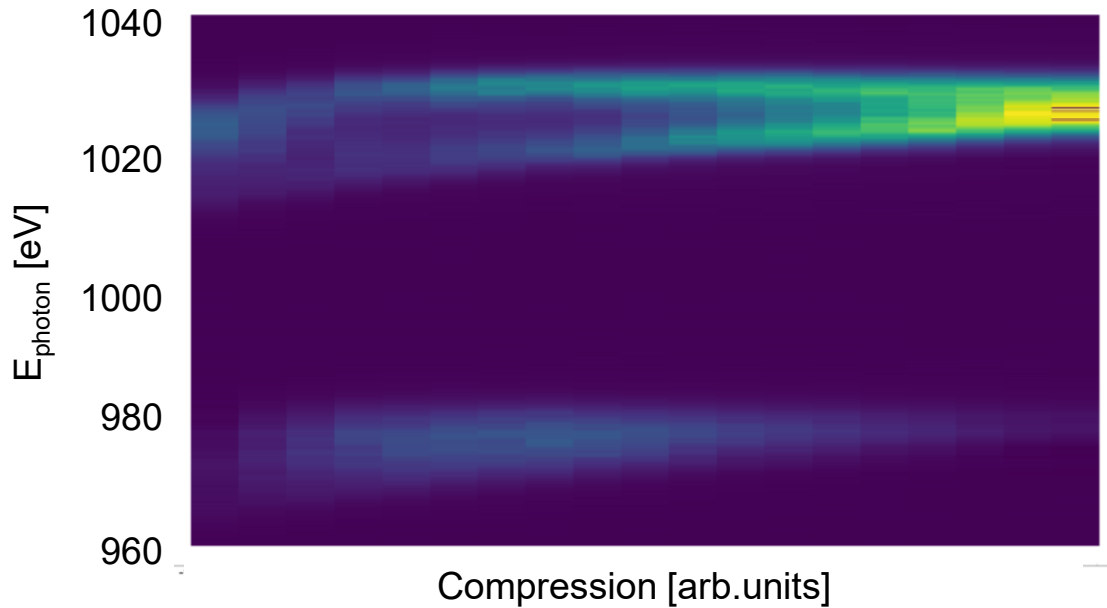

- Caused by energy chirp in the beam and spoilage of its high-current core by the first color

- Bifurcation of the second color during 2-color operation

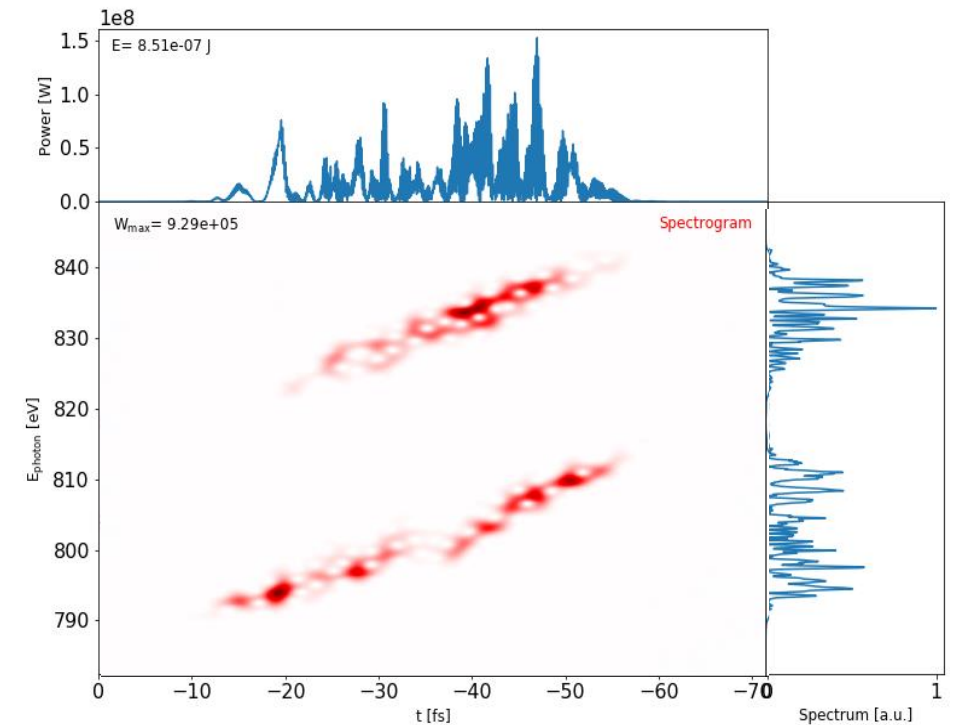

# Set-up for chirp + dispersion-assisted fresh-slice

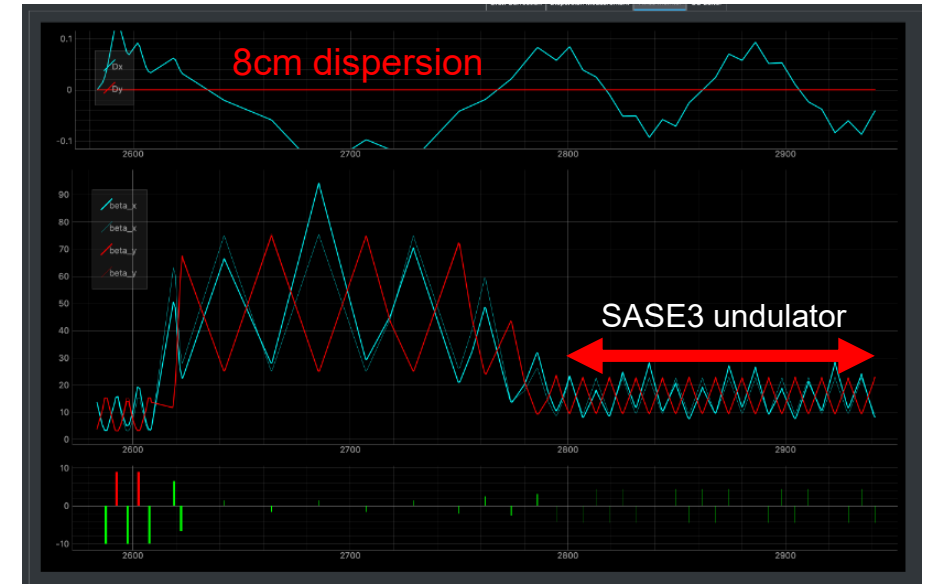
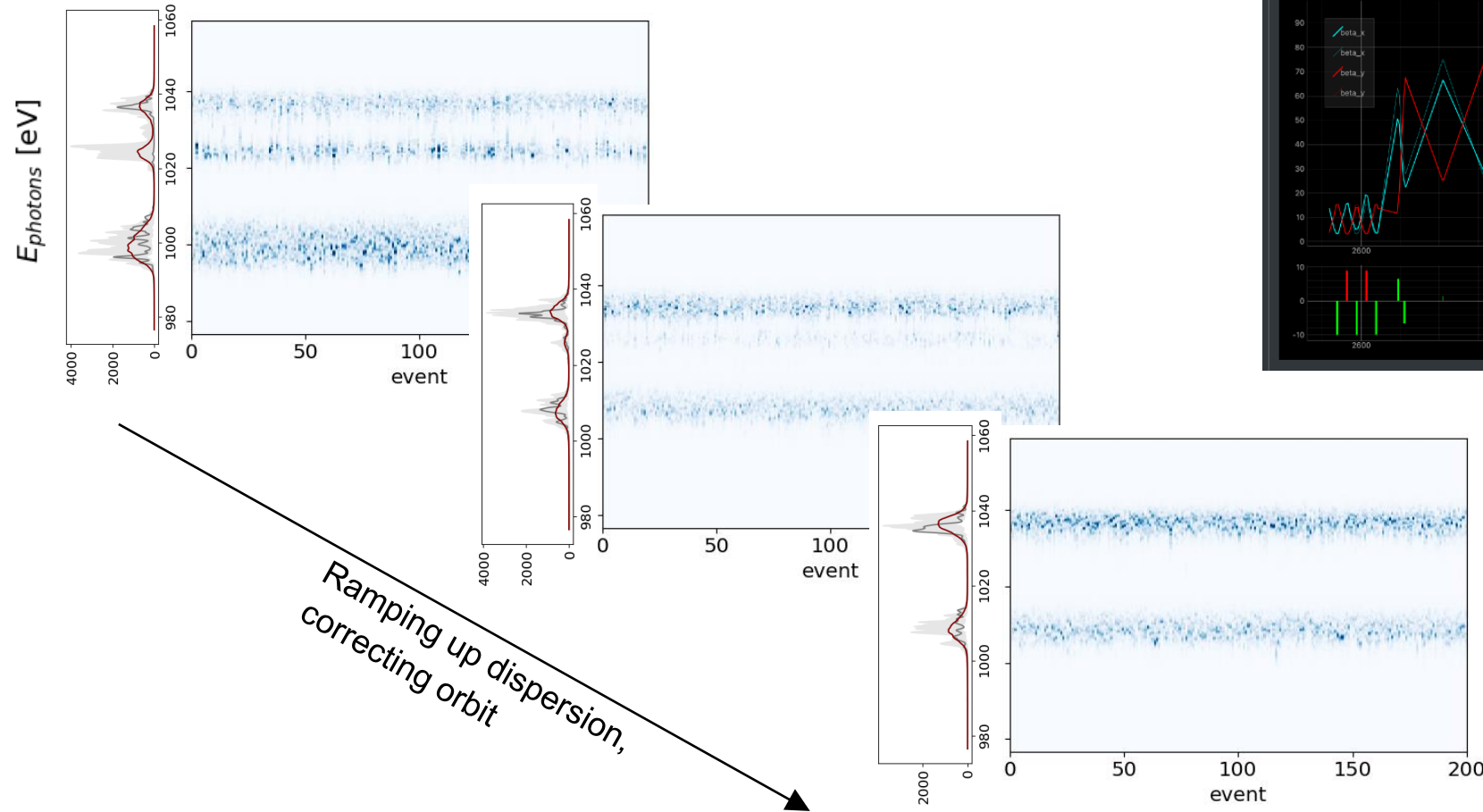

Control Room tool MANUL



## Two high-power pulses with duration <15fs and negative delay

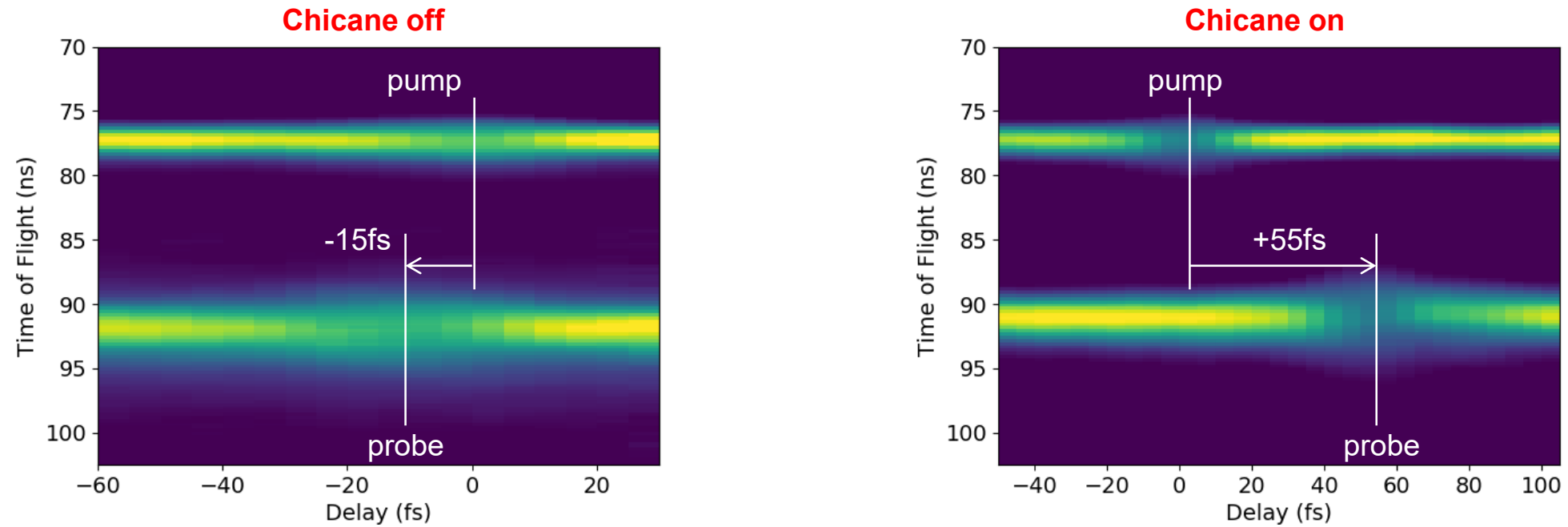

- Photoelectrons from gas + optical laser
- Two X-ray colors -> two photoelectron energies
- Optical laser “smears” photoelectron energy
- Observed zero crossing of both colors



## Shortening pulses further

# One way to reduce lasing window (i.e. achieve shorter pulses) is to misalign orbit of different slices of e-beam

J. Opt. 20 (2018) 024005

Review

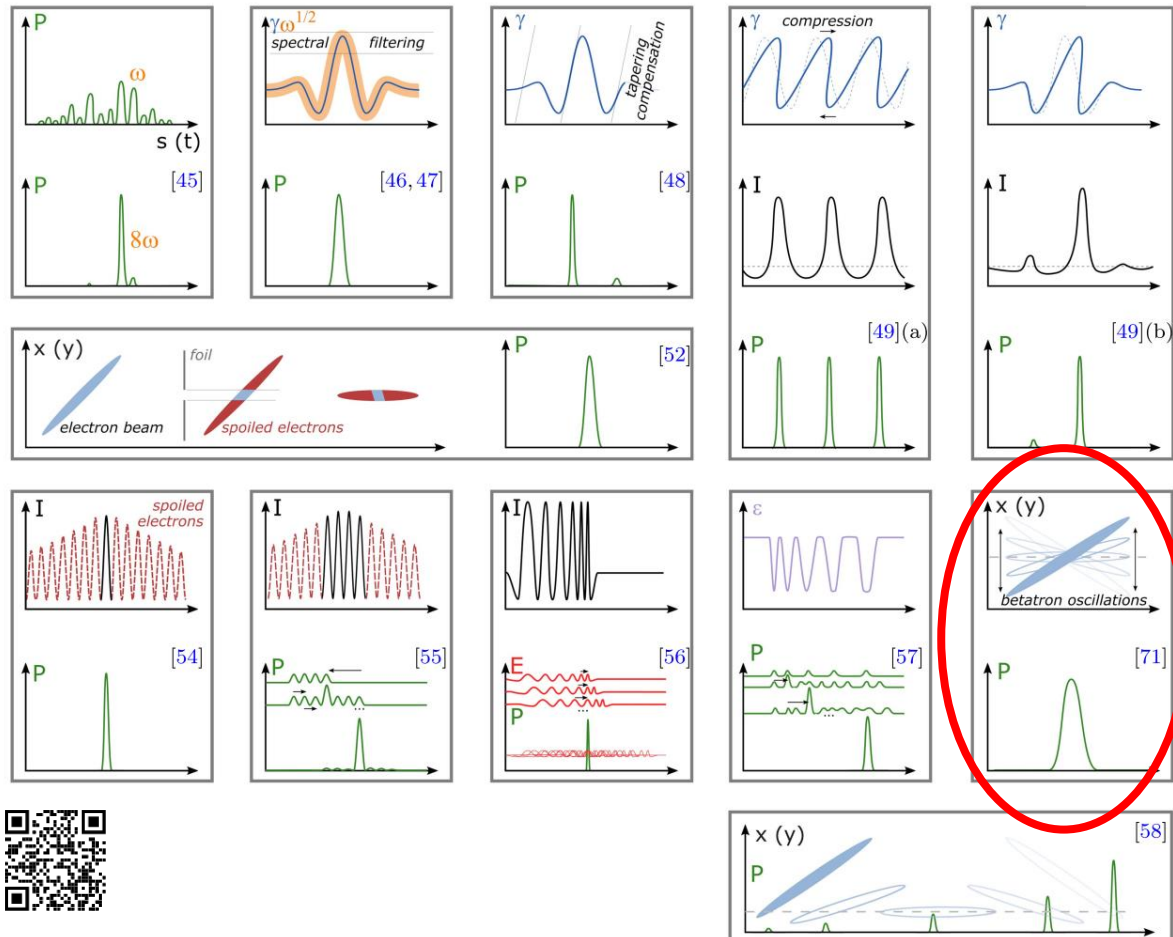

**Figure 1.** Schematic illustrations of different concepts to obtain sub-femtosecond FEL pulses. Subfigure indexes are the reference citation numbers. Horizontal axes correspond to longitudinal coordinate  $s$  along the radiation/electron beam, vertical axes encode: P-radiation power,  $\gamma$ -electron beam energy,  $\omega$ -radiation frequency, I-electron beam current, E-electric field of the radiation,  $\varepsilon$ -electron beam emittance,  $x(y)$ -any of transverse coordinates across an electron beam.

- We do it similarly to [71] but
- Chirp originates from non-linear compression + self-effects
- adjust the quadrupole in dispersive section instead of „bumping“ the orbit there
- Deviation of electron energy + dispersion = deviation of orbit for off-energy particles

[45] E. Saldin, et al., *Opt. Commun.* 212 377–390 (2002)  
(see **MOA03** by A. Trebushinin)

[48] E. Saldin, et al., *Phys. Rev. Spec. Top. Accel. Beams* 9 050702 (2006)  
(see **MOP22** by J. Yan, **TUP18** by M. Guetg)

[71] A. Lutman, et al, *Nat. Photonics* 10, 745 (2016) ;  
M. Guetg, et al., *Phys. Rev. Lett.* 120, 264802 (2018)



# Nonlinear e-beam compression creates ~2% non-linear energy chirp

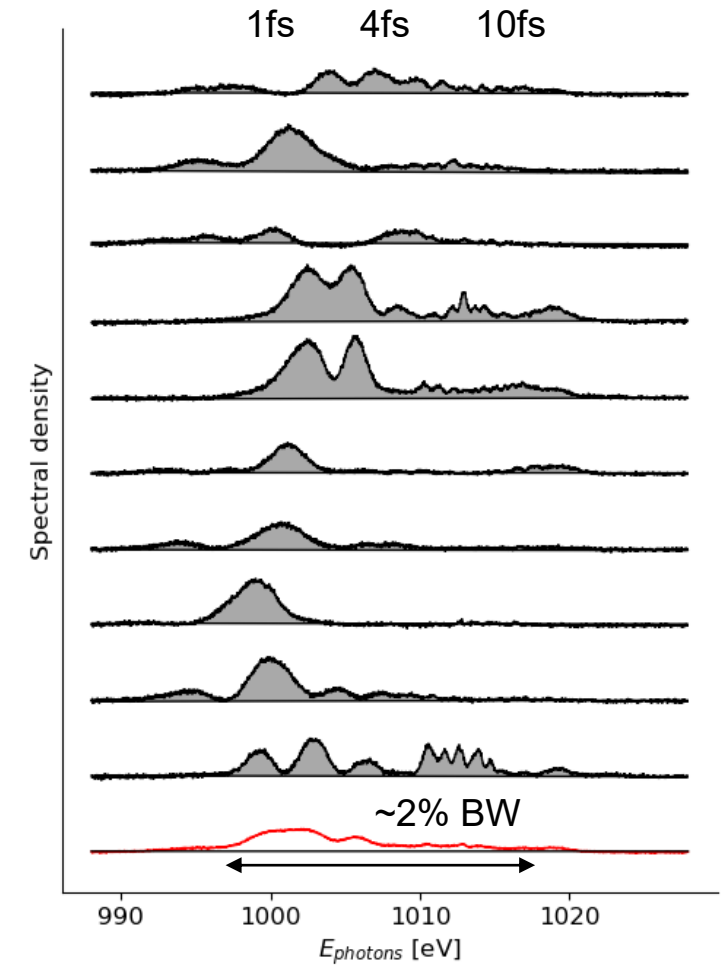
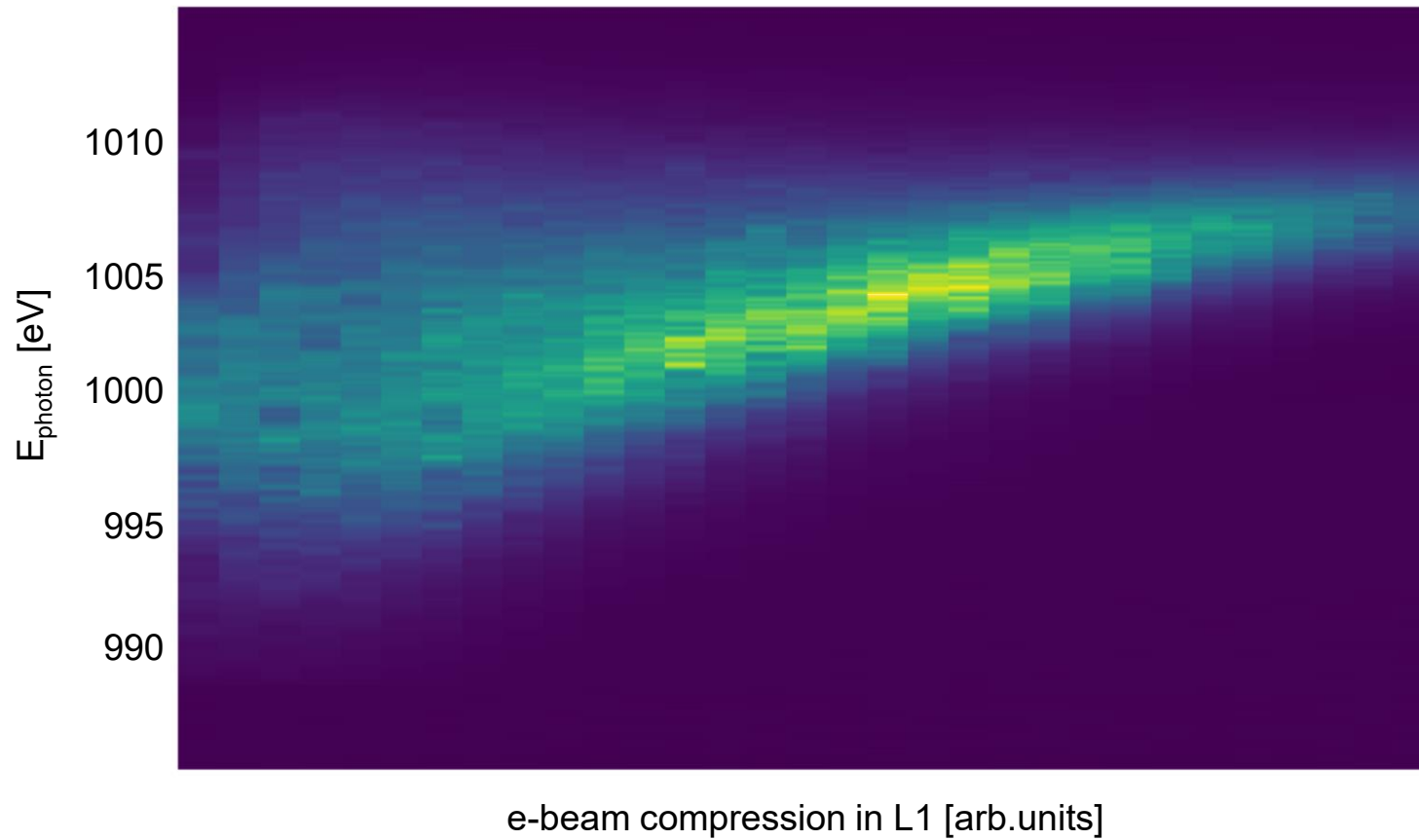

# Ramping up [horizontal] orbit dispersion

## Chirp + orbit dispersion = radiation angular dispersion

Illustration of optimization

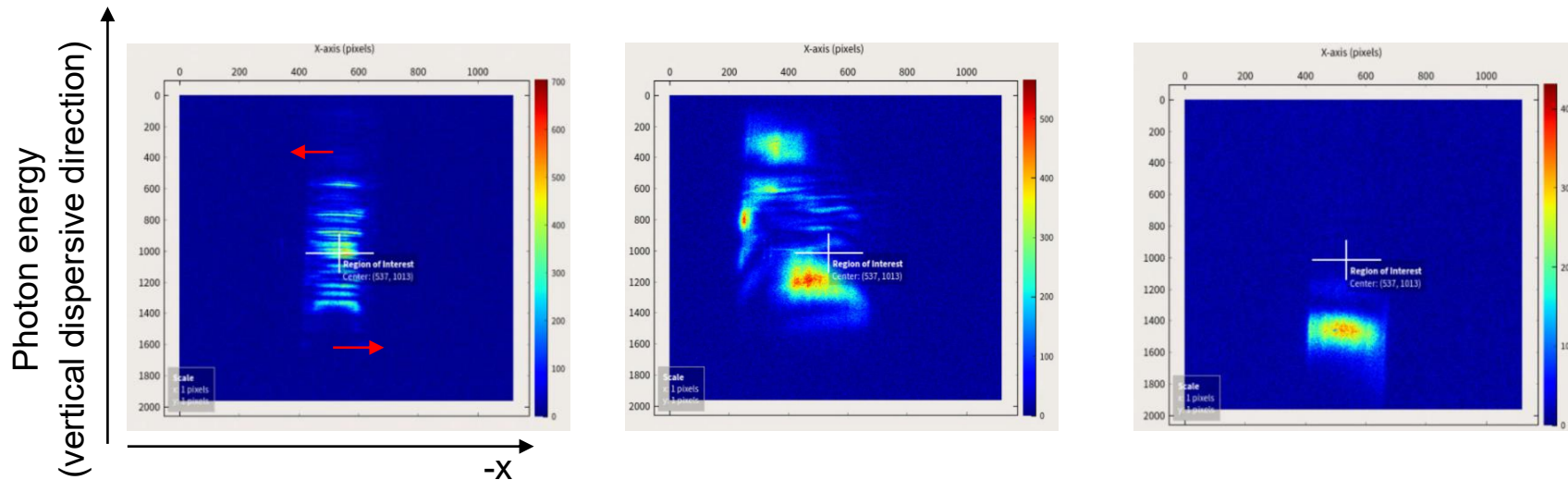

■ SASE3 spectrometer exit slit imager

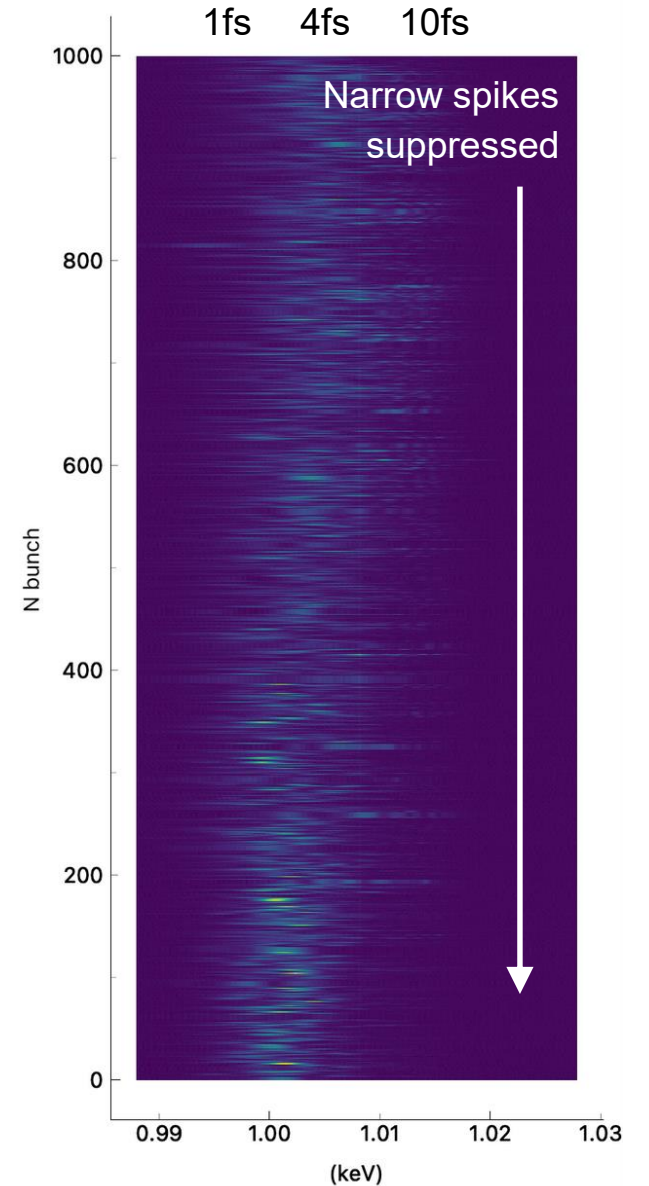

# Quadratic chirp + dispersion

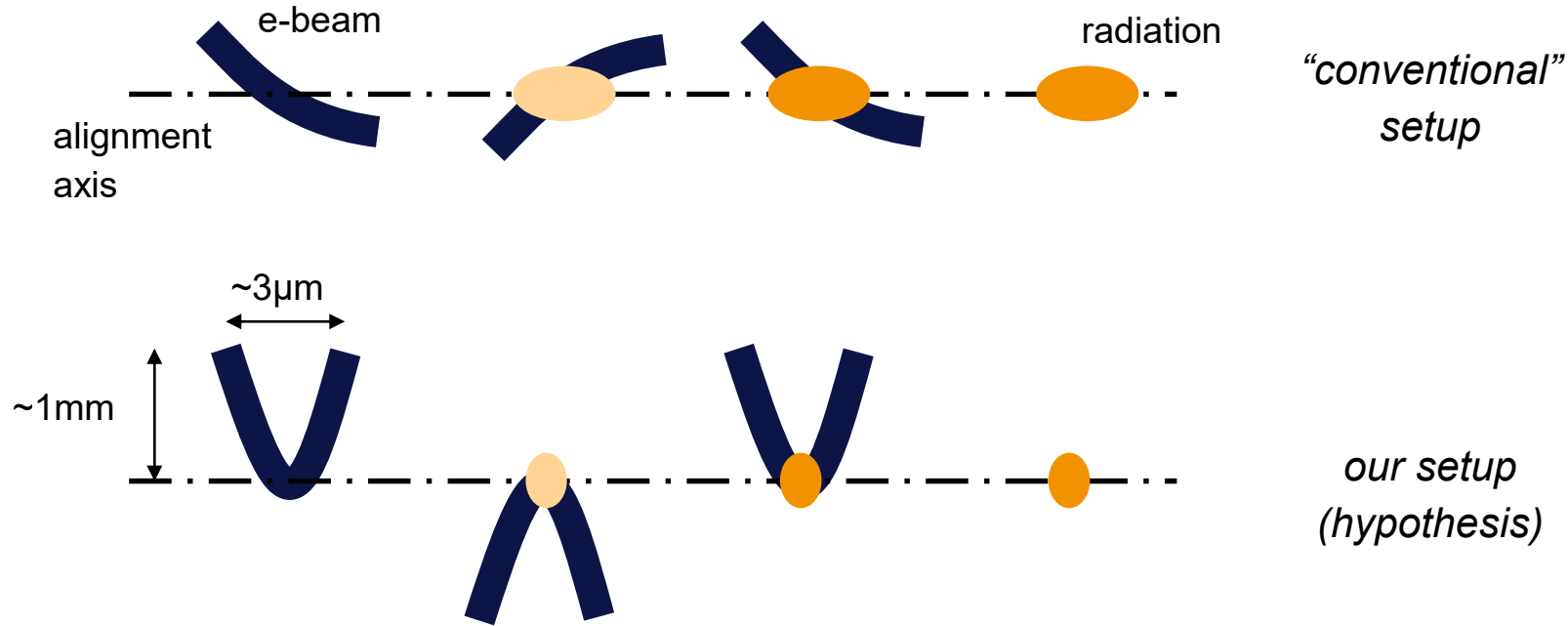

■ Evolution of the spectrum while changing dispersion suggests that in the presence of quadratic chirp we [eventually] aligned a short high-current core of the bunch on axis

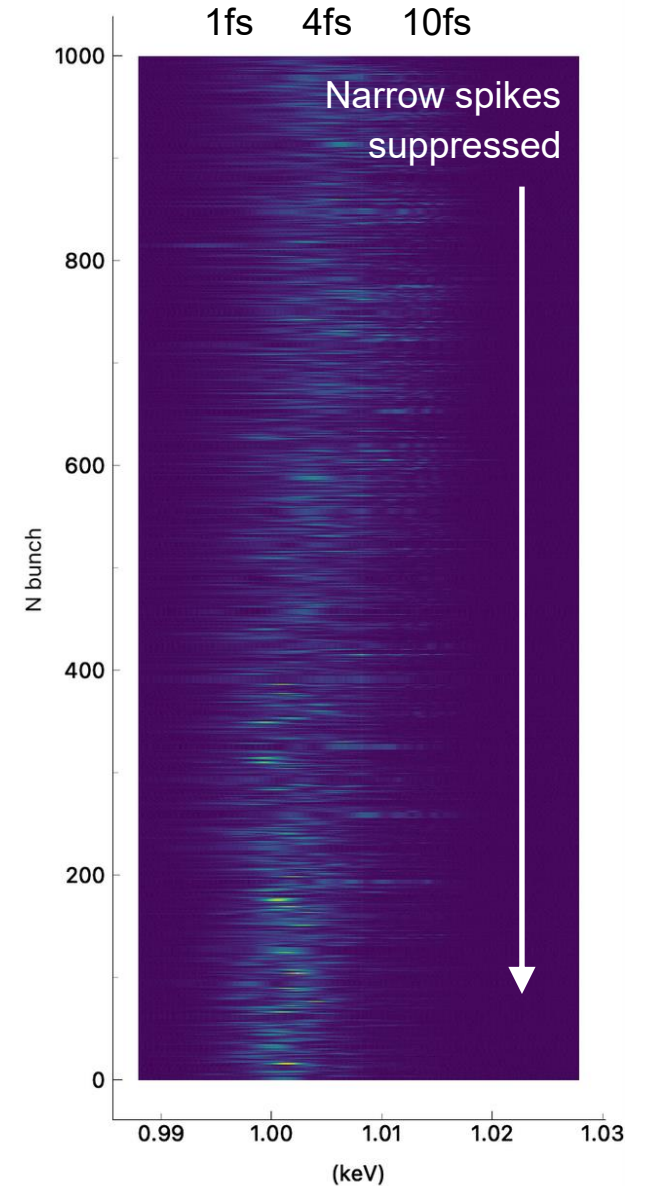

# Quadratic chirp + dispersion

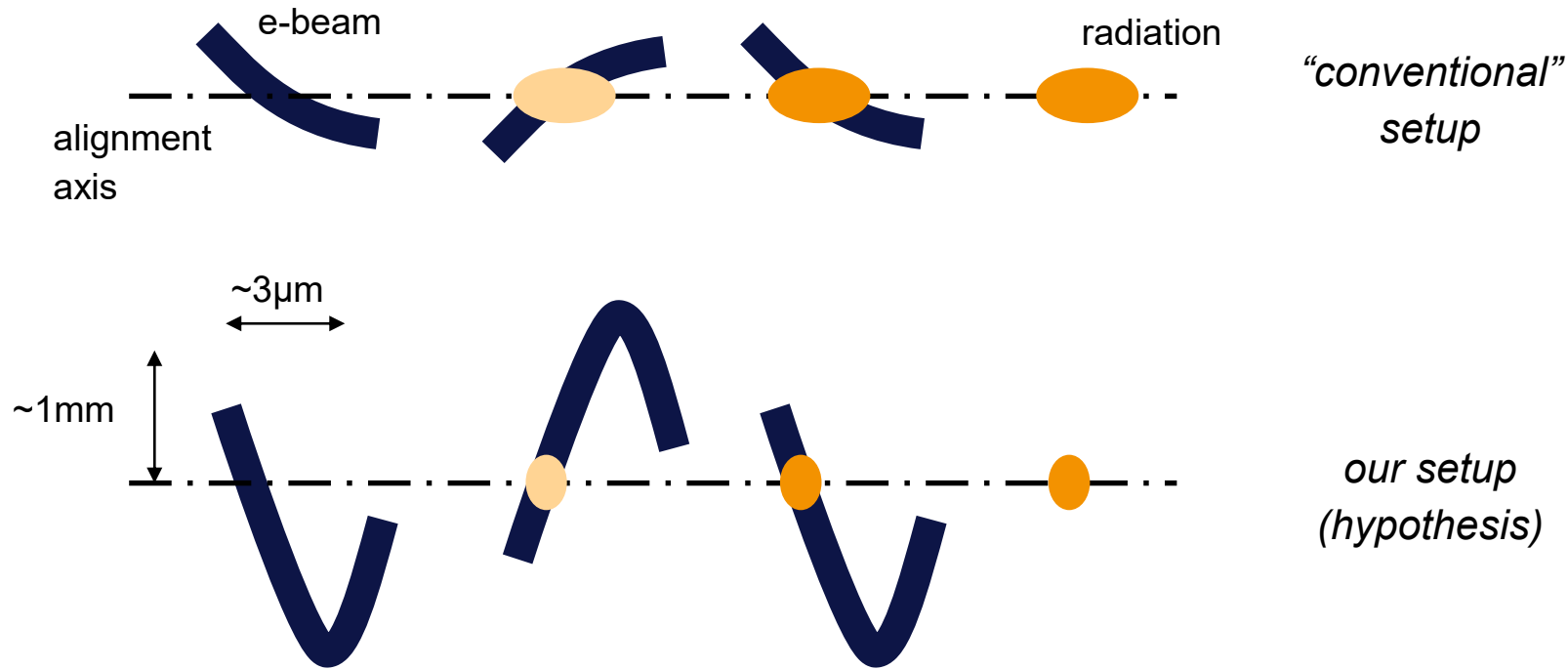

■ Evolution of the spectrum while changing dispersion suggests that in the presence of quadratic chirp we [eventually] aligned a short high-current core of the bunch on axis

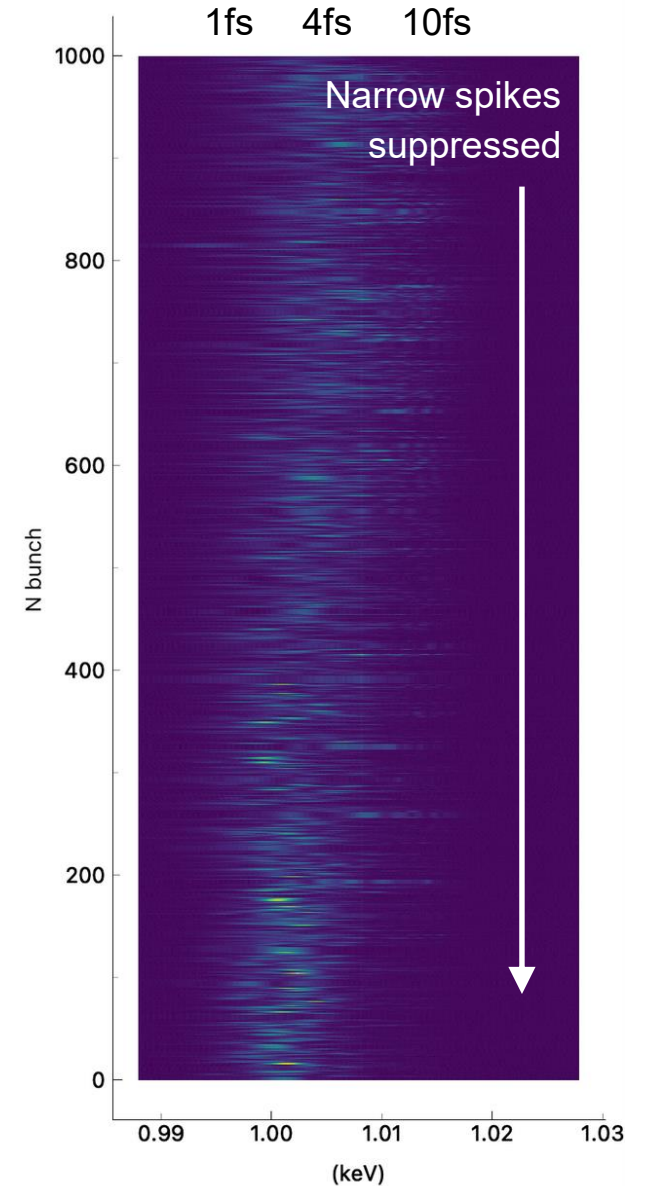

## Short pulses (single spikes) at SASE3

- **Strong compression combined with electron beam orbit dispersion** resulted in broader and less numerous spikes (i.e. shorter, fs-order pulses)
- Demonstrated twice at **16.5 GeV** however may work at lower electron energies as well
- Direct pulse duration diagnostics pending
  - ~~Waiting for data analysis~~

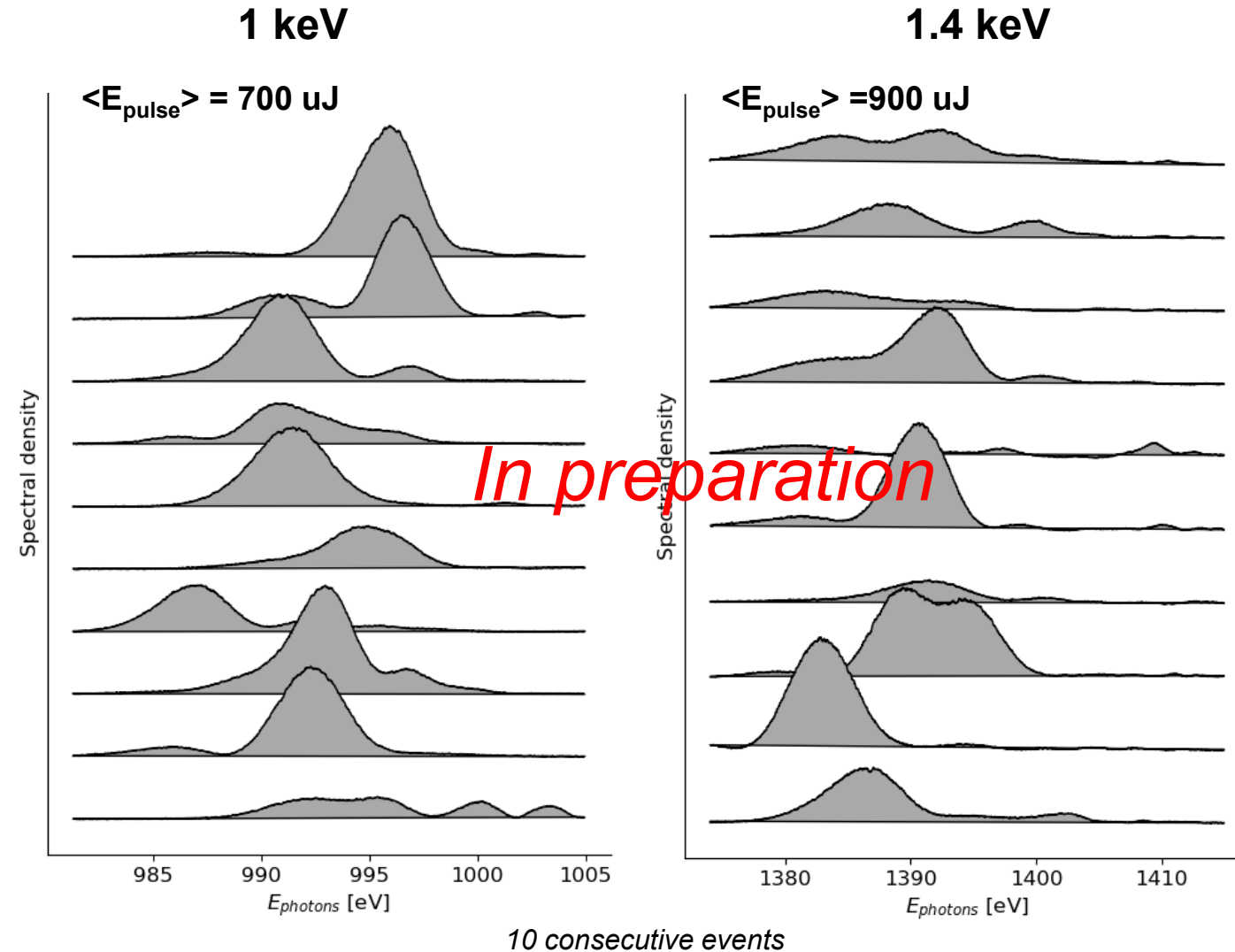

# Streaking reconstruction from June beamtime at SQS

- Preliminary streaking results

- by Lars Funke, Markus Ilchen, Wolfram Helml et al.

- Measured on June 18<sup>th</sup> at SQS

- $t_{\text{fwhm}} \sim 2/3$  fs

*(result of streaking reconstruction,  
isolated spike with sub-fs duration)  
In preparation*

# Replicating with Genesis simulation, quadratic chirp

- We assume model electron beam
  - 16.5 GeV, 10kA flat-top, quadratic chirp
- 0 cm transverse dispersion in the undulator
- We observe quadratic frequency chirp of SASE radiation
  - Asymmetric spikes width

*(simulated plot of a frequency-chirped pulse)*

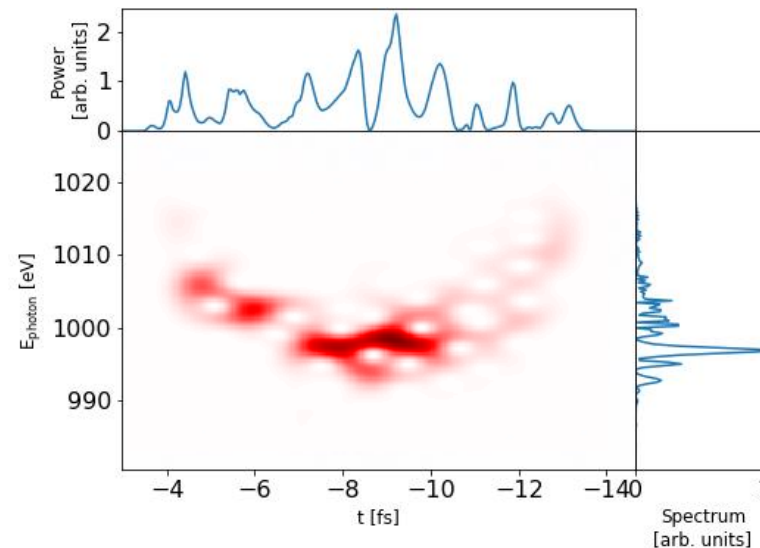

# Replicating with Genesis simulation, angular radiation dispersion during setup

- We assume model electron beam
  - 16.5 GeV, 10kA flat-top, quadratic chirp
- 4 cm transverse dispersion in the undulator
- Observe reduction of lasing window and tilt on spectrometer imager

*In preparation*

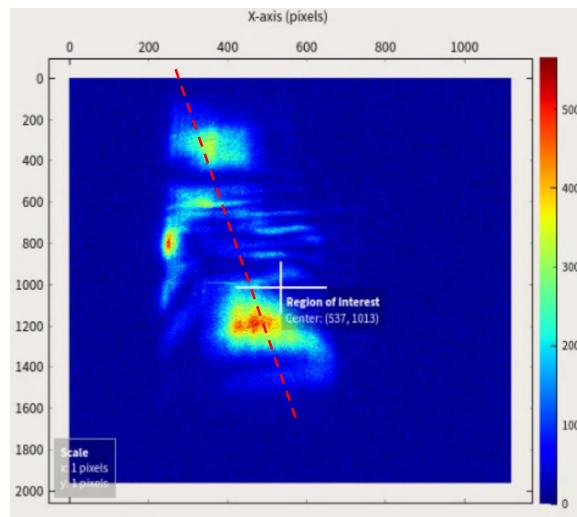

## Replicating with Genesis simulation, single spikes

- We assume model electron beam
  - 16.5 GeV, 10kA flat-top, quadratic chirp
- 8 cm transverse dispersion in the undulator
- Lasing window reduces to a single-ish spike
  - About 700uJ pulse energy

*(simulated plot of an isolated spike)*

*In preparation*



## Attempt of 2-color operation with short pulses

- Short pulse set-up combined with split undulator 2-color setup
- Generated 2 pulses approaching 1 spike with 260 uJ combined pulse energy combined at 16.5 GeV with 25 fs delay
- Demonstrated once
- Fresh-slice should mitigate correlation

*(plot with isolated spikes at two photon energies)*

*In preparation*

## Attempt of 2-color operation with short pulses

- Short pulse set-up combined with split undulator 2-color setup
- Generated 2 pulses approaching 1 spike with 260 uJ combined pulse energy combined at 16.5 GeV with 25 fs delay
- Demonstrated once
- Fresh-slice should mitigate correlation

*(plot with isolated spikes at two photon energies)*

*In preparation*

## Conclusions and Outlook

- In SASE3 we benefit from
  - Up to 16.5 GeV electron beam, long drift to undulator
  - 105 m of magnetic length with K up to 9, split by chicane with up to ps-order delay
  
- We deliver 2-color pump-probe radiation to users
  - With ps-order maximum delay, up to mJ per pulse
  - To be upgraded with ODL (negative delay, improved delay scan stability, switch off pump)
  - Demonstrated dispersion-based fresh-slice 2-colors
  
- We achieved single spike pulses at 1keV with sub-mJ energy
  - Reduces pulse length down to fs-order coherence time
  - Reasonable agreement with simulations
  - Applicable to 2 colors, need further studies
  - Stepping stone towards more advanced methods
    - ▶ (e.g. see MOP22 by J.Yan and TUP18 by M.Guetg)
  - Findings in preparation

# 2-color SXR project progress (12 years)

- 20.01.2010 G.Geloni, V.Kocharyan, E.Saldin arXiv:1001.3506
- 30.01.2014 2-color possibility mentioned at XFEL user's meeting
- 15.04.2016 2-color discussed at PBS meeting with sci. case for SQS
- 05.2016 Start of funding discussions
- 24.01.2017 2-color capabilities presented at XFEL User's meeting
- 02.02.2017 Funding from the Finnish academy of science for chicane granted
- 04.2018 Chicane design concept
- 15.05.2019 First 2-color lasing at EuXFEL SASE3 without pulse delay
- 03.08.2020 Chicane commissioning
- 10.10.2020 2 colors with picosecond & negative delays at EuXFEL
- 21.10.2021 Femtosecond-order pump-probe generation

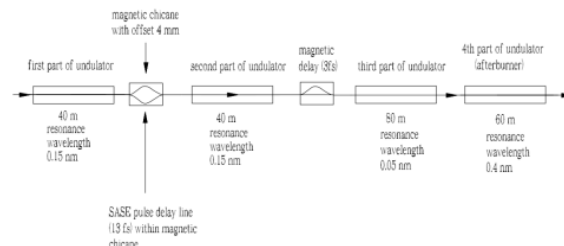

**Two color XFEL operation in SASE3 beamline for time resolved experiments**

SXRSS Monochromator installation allows another option of FEL operation (only chicane is used in this case) **for free**

- Undulators are divided into two sections and tuned for different wavelengths
- Undulators operate in conventional SASE mode
- Delay between pulses can be controlled:  $\Delta t \sim 0-1$  ps with up to 0.1-fs resolution
- Two wavelengths are tunable with maximum separation up to  $\Delta\lambda \sim 50\%$
- Single pulse length is limited by electron bunch length (down to 5fs)

Source: Serkez | Design and principles of operation of SASE3 FEL SXRSS Monochromator | 20210214 | Page 12

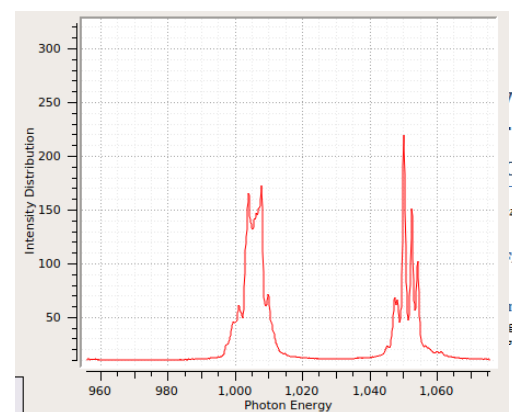

## Two colors at SASE3: Chicane design choice for the "2CPP" Finnish-EuXFEL collaboration project

by Svitozar Serkez, The European XFEL SPF, preface by E. Kükk (Univ. of Turku)

**ABSTRACT**

**Context**

Project has been granted by the Finnish Academy of Sciences for constructing a device at SASE3 undulator with cooperation by XFEL FI to define the two-color capability and enable pump-probe experiment at the endstation.

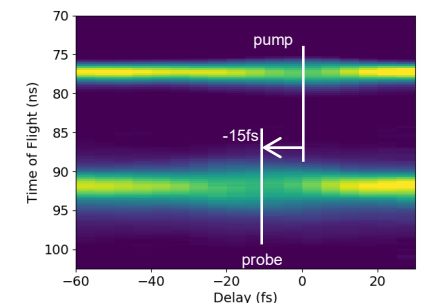

# Our big team

## ■ DESY

- F. Brinker, W. Decking, L. Froehlich, M. Guetg, O. Hensler, F. Jastrow, V. Kocharyan, Y. Kot, B. Lautenschlager, S. Liu, S. Meykopff, N. Mirian, W. Qin, E. Saldin, E. Schneidmiller, M. Scholz, H. Sinn, S. Tomin, T. Wamsat, T. Wilksen, M. Yurkov, I. Zagorodnov,
- High Level Control team, Run coordinators, Operators

## ■ XFEL

- R. Boll, A. DeFanis, M. Dommach, G. Geloni, N. Gerasimova, J. Gruenert, P. Grychtol, S. Karabekyan, A. Koch, J. Laksman, Th. Maltezopoulos, T. Mazza, L. Mercadier, M. Meyer, D. Rivas, A. Scherz, T. Tanikawa, A. Trebushinin, S. Usenko, A. Yaroslavtsev
- Photon run coordinators

## ■ Finnish collaboration:

- M. Huttula, E. Kukk

## ■ Technical implementation of the magnetic chicane and optical delay line:

W. Decking, G. Wellenreuther, C. Engling, J. Hauschild, C. Holz, B. Krause, M. Laub, E. Negodin, R. Wichmann, T. Wohlenberg, D. Thoden, D. LaCivita, P. Gessler, J. Grünert, A. Koch, S. Lederer, M. Makita, M. Planas, M. Tavakkoly, P. Thute, M. Vannoni

## ■ Discussions, other:

- J. Yan, C. Lechner, A. Benedictovich, P. Lytaev, A. Picchiotti, A. Rouze,