

Review and Current Status of the 70 MeV High Intensity Proton Cyclotron at LNL

MARIO MAGGIORE ON BEHALF OF LNL CYCLOTRON TEAM

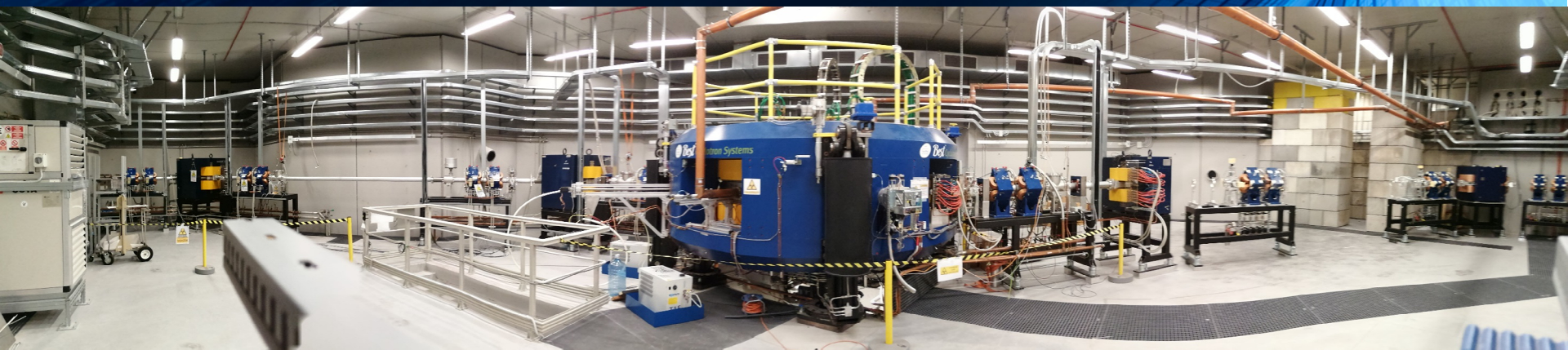

Laboratori Nazionali di Legnaro - INFN

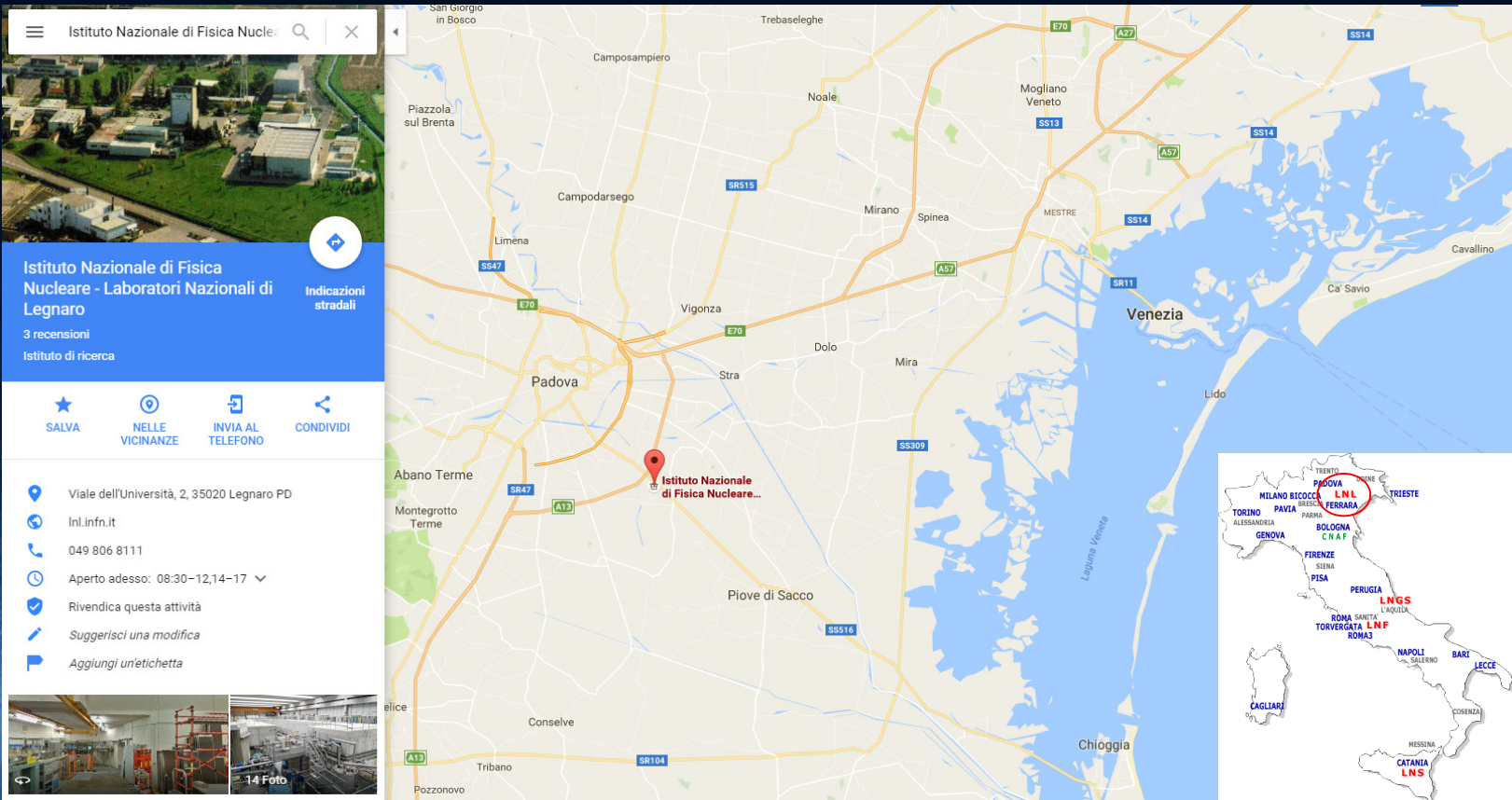

Istituto Nazionale di Fisica Nucleare - Laboratori Nazionali di Legnaro

3 recensioni
Istituto di ricerca

SALVA **NELLE VICINANZE** **INVIA AL TELEFONO** **CONDIVIDI**

Viale dell'Università, 2, 35020 Legnaro PD
 Inl.infn.it
 049 806 8111
 Aperto adesso: 08:30-12,14-17
 Rivendica questa attività
 Suggestisci una modifica
 Aggiungi un'etichetta

14 Foto

Accelerators at Legnaro Labs

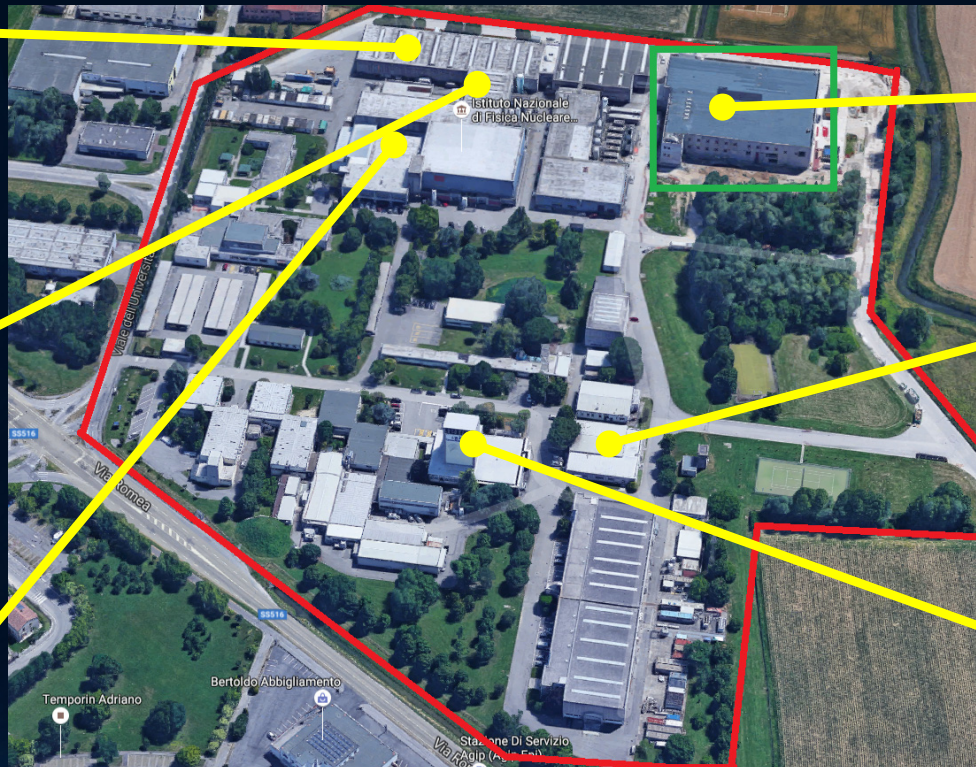
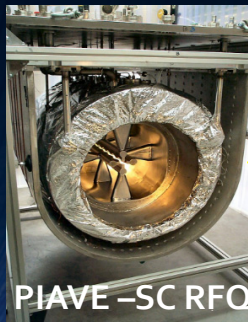

SPES: Selective Production of Exotic Species

- Flagship of INFN on Nuclear Physics and Astrophysics Research
- 50 Meuro budget fully funded (Alpha and Beta phases)
- It consists of 4 phases:
 - **Alpha**: Cyclotron (proton beam driver) and High Intensity Beam Delivering
 - **Beta**: RIBs production and Physics at Low and High Energy (Re-acceleration)
 - **Gamma**: R&D on Radioisotope for Medical Application (LARAMED project,)
 - **Delta**: Neutron sources generation and Applications
- Construction phase started in 2010 with Cyclotron and in 2012 with the dedicated building
- Completion of SPES Project (Alpha and Beta) is expected in 2023

Second generation ISOL facility for nuclear physics: Production & re-acceleration of exotic beams. Neutron-rich ions from p-induced Fission on UCx (10^{13} f/s), 10 MeV/amu

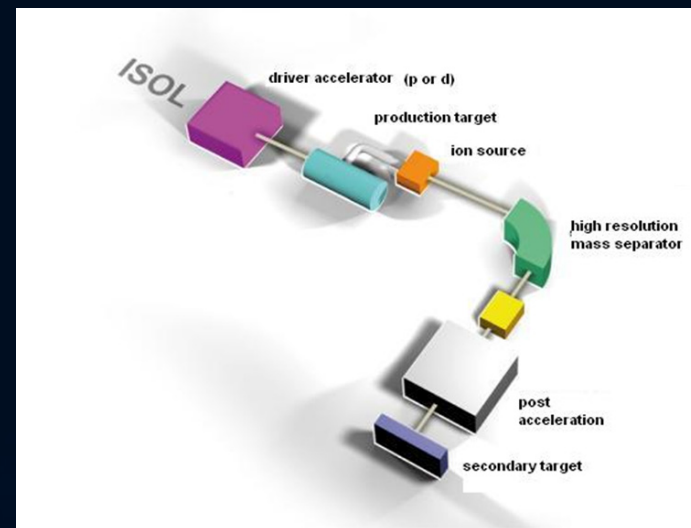

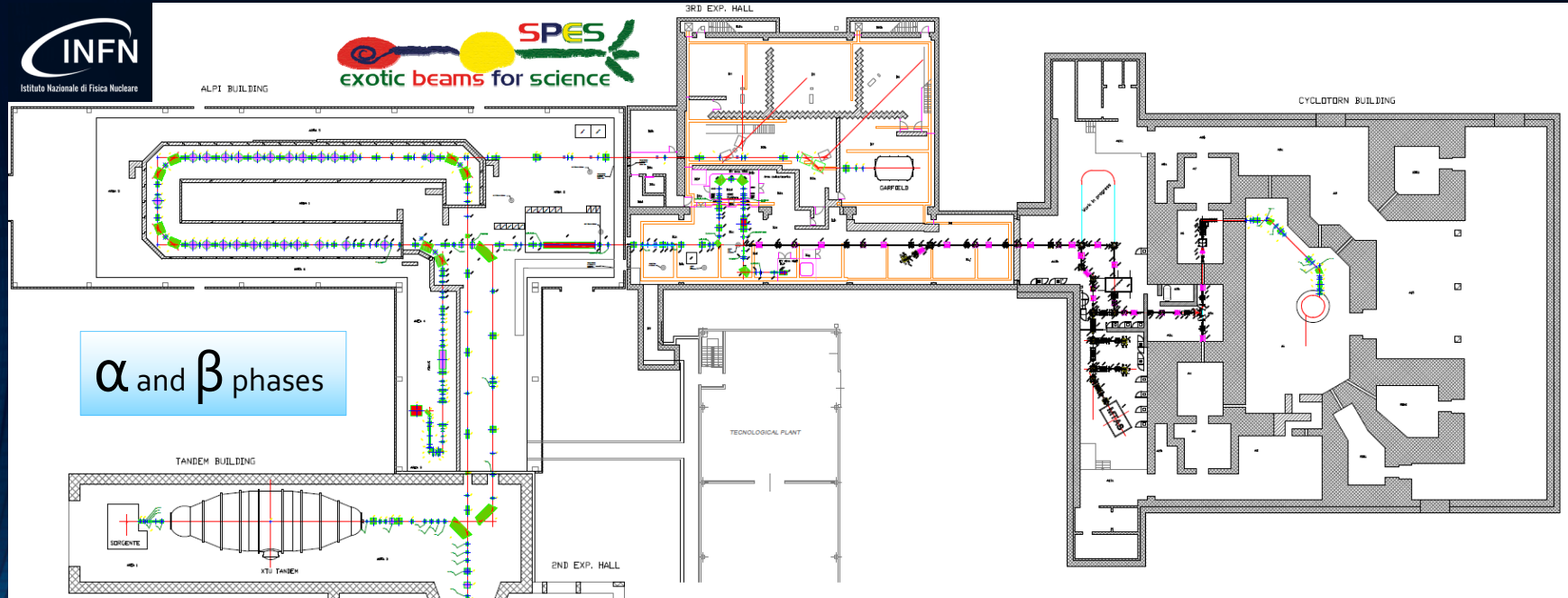

- Cyclotron and beamline completed and operational
- ISOL target on test stand
- HRMS and beam cooler under construction
- Charge Breeder ready for commissioning with stable beam
- New RFQ injector under construction
- ALPI upgrade is carrying on

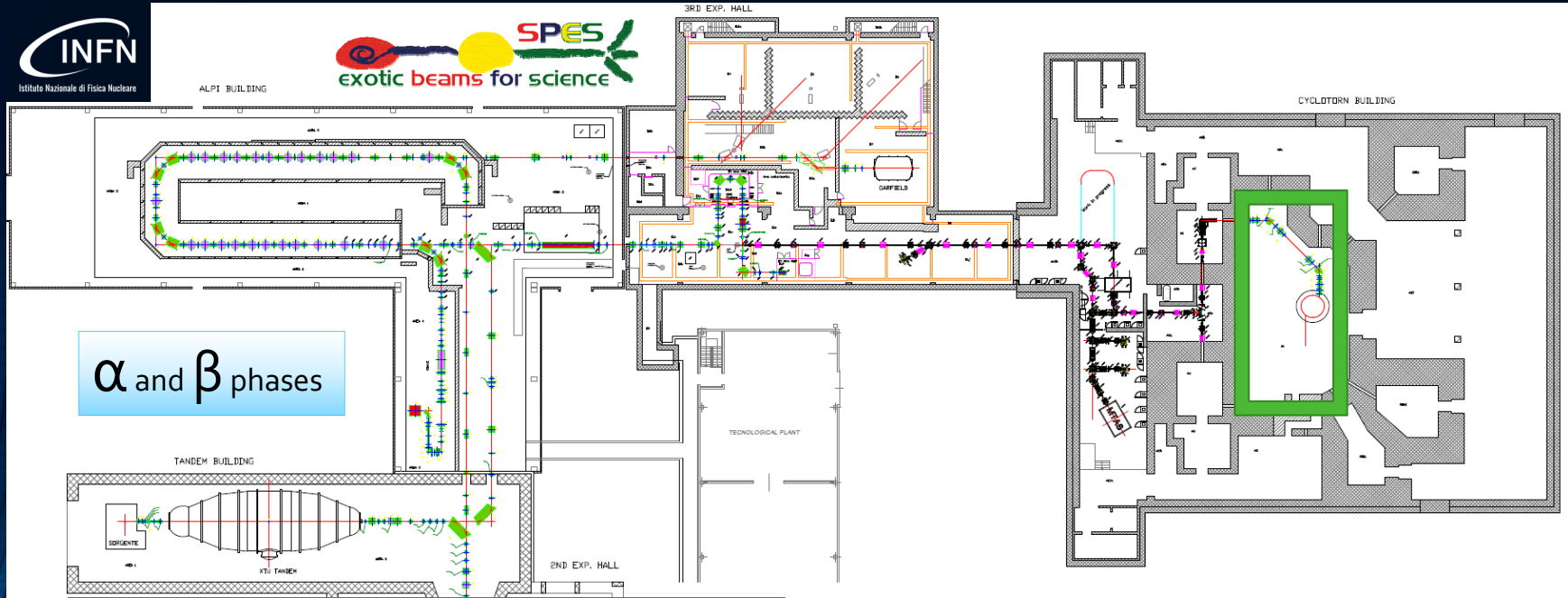

- Cyclotron and beamline completed and operational

- ISOL target on test stand

- HRMS and beam cooler under construction

- Charge Breeder ready for commissioning with stable beam

- New RFQ injector under construction

- ALPI upgrade is carrying on

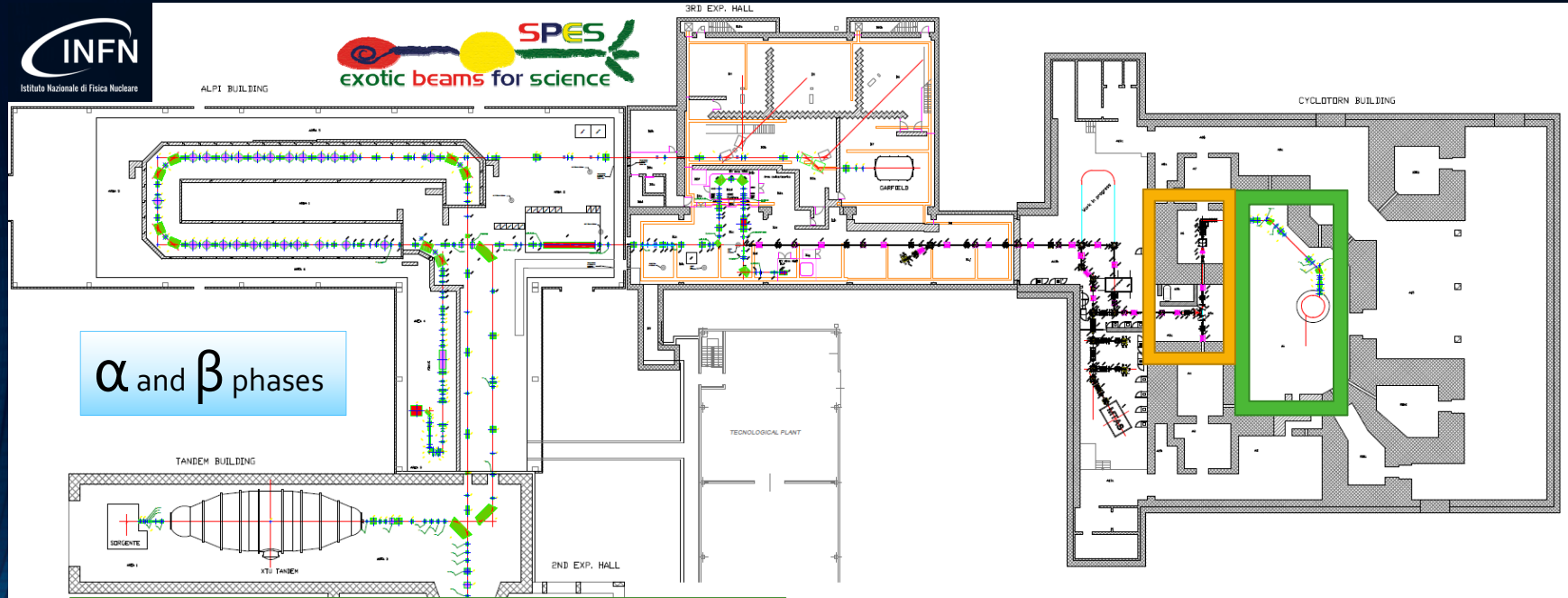

- Cyclotron and beamline completed and operational

- ISOL target on test stand

- HRMS and beam cooler under construction

- Charge Breeder ready for commissioning with stable beam

- New RFQ injector under construction

- ALPI upgrade is carrying on

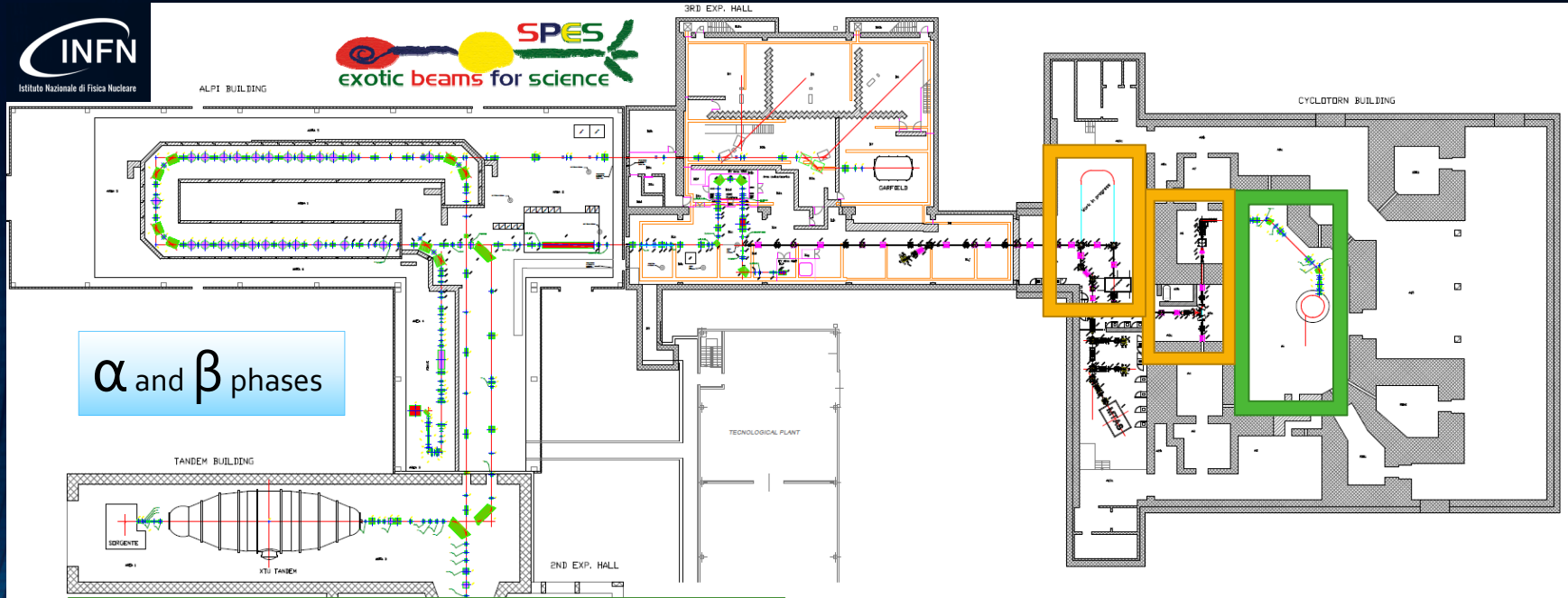

- Cyclotron and beamline completed and operational

- ISOL target on test stand

- HRMS and beam cooler under construction

- Charge Breeder ready for commissioning with stable beam

- New RFQ injector under construction

- ALPI upgrade is carrying on

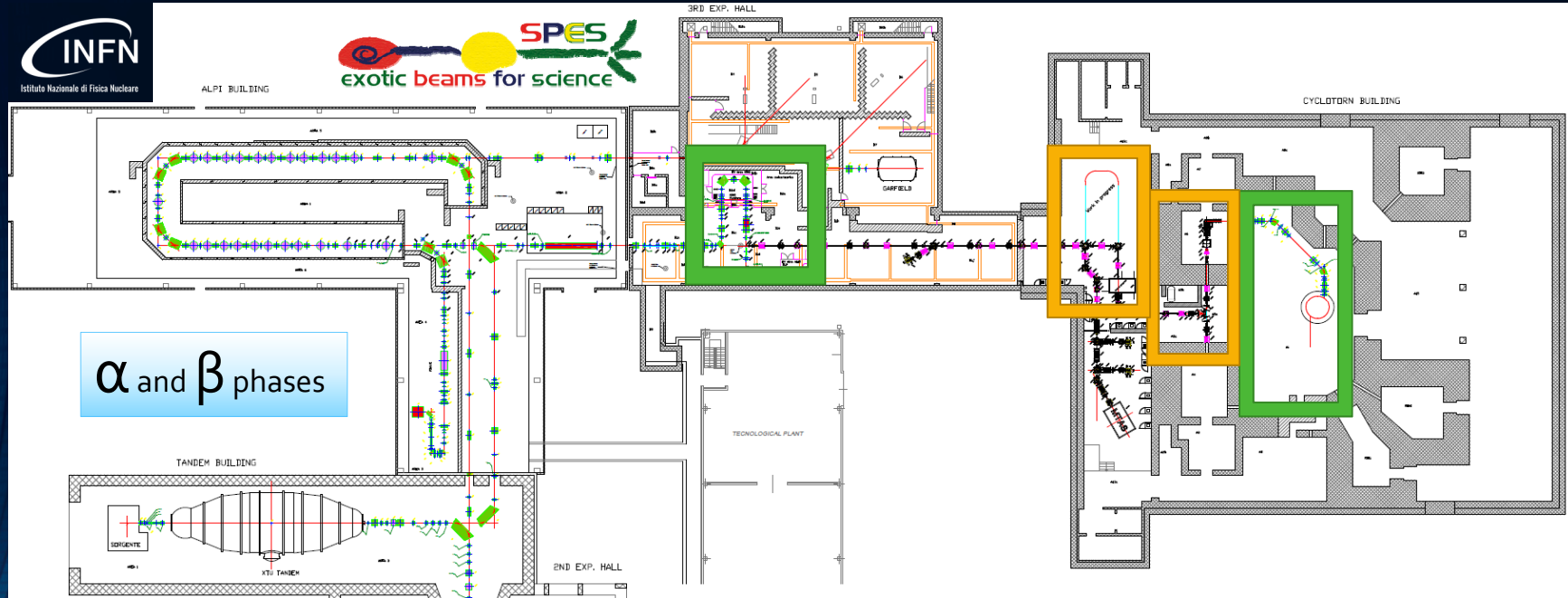

- Cyclotron and beamline completed and operational

- ISOL target on test stand

- HRMS and beam cooler under construction

- Charge Breeder ready for commissioning with stable beam

- New RFQ injector under construction

- ALPI upgrade is carrying on

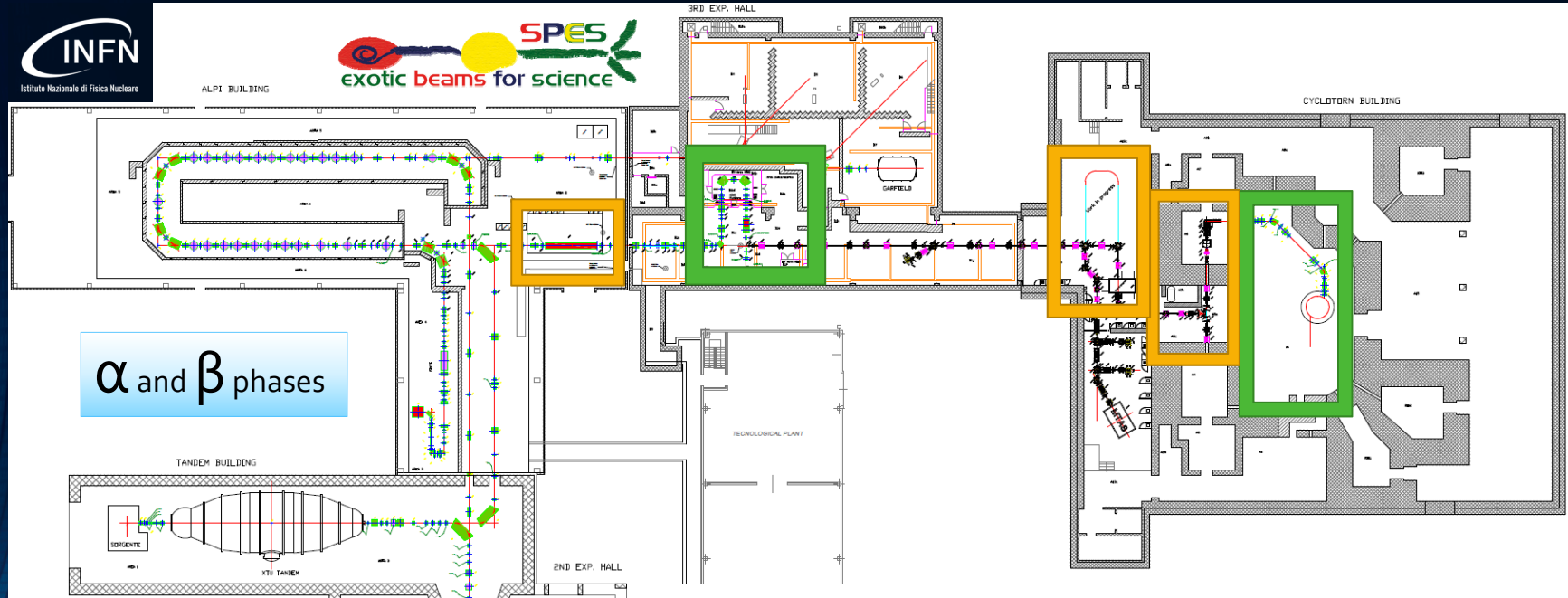

- Cyclotron and beamline completed and operational

- ISOL target on test stand

- HRMS and beam cooler under construction

- Charge Breeder ready for commissioning with stable beam

- New RFQ injector under construction

- ALPI upgrade is carrying on

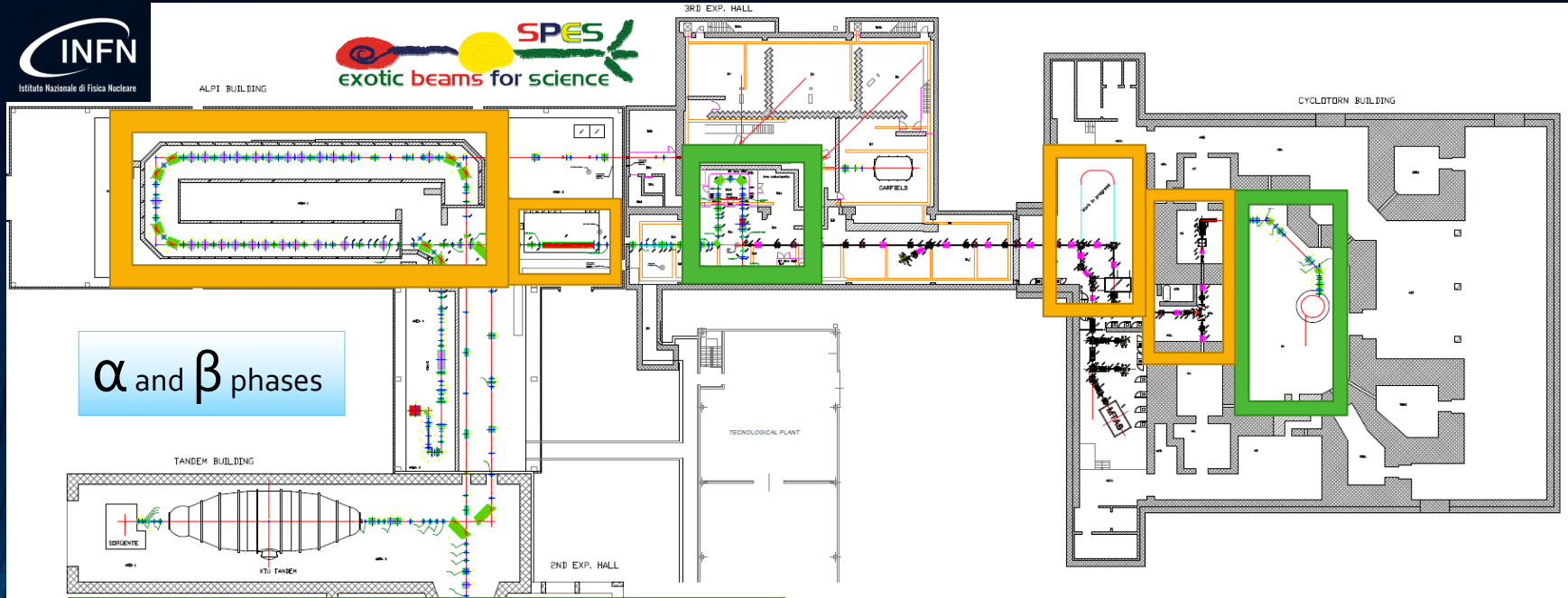

- Cyclotron and beamline completed and operational

- ISOL target on test stand

- HRMS and beam cooler under construction

- Charge Breeder ready for commissioning with stable beam

- New RFQ injector under construction

- ALPI upgrade is carrying on

High Intensity Proton Beam Facility for SPES

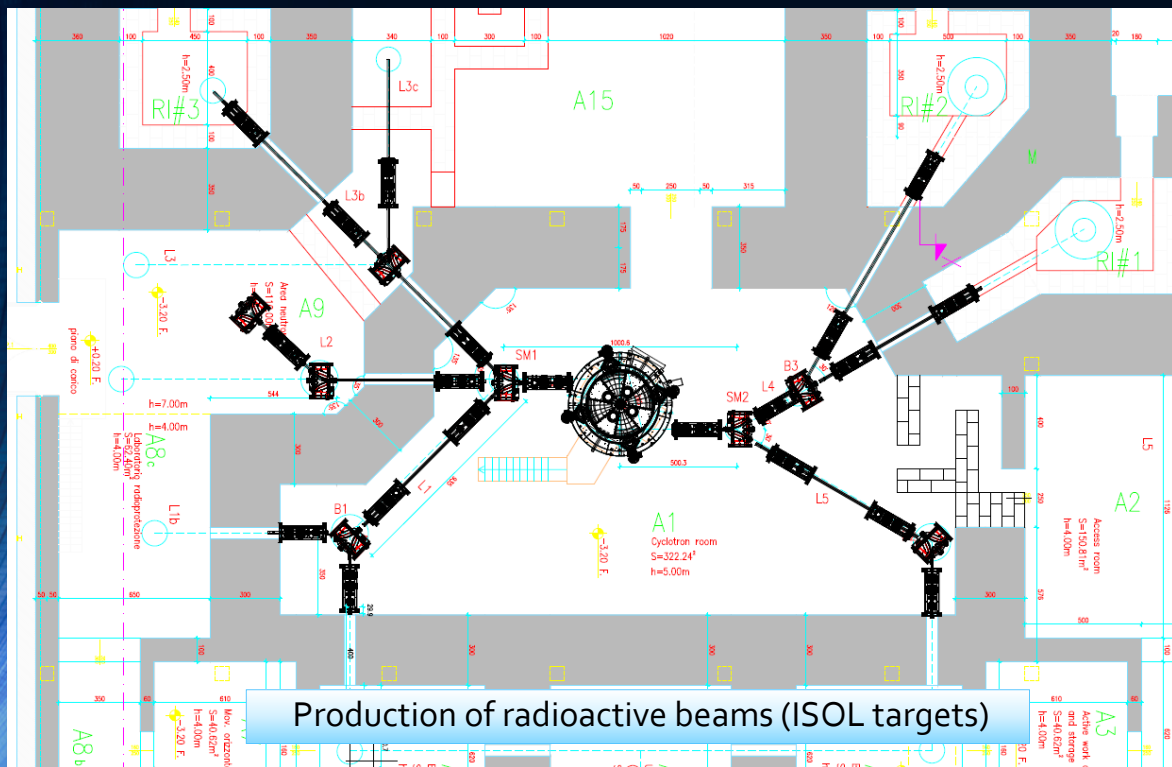

- Up to 9 irradiation target points
- 2 ISOL target stations (A6, A4)
- 3 Shielded bunkers (RI #1, #2, #3) for High Intensity irradiation
- 4 medium and low intensity target areas (A8, A9, A15)

High Intensity Proton Beam Facility for SPES

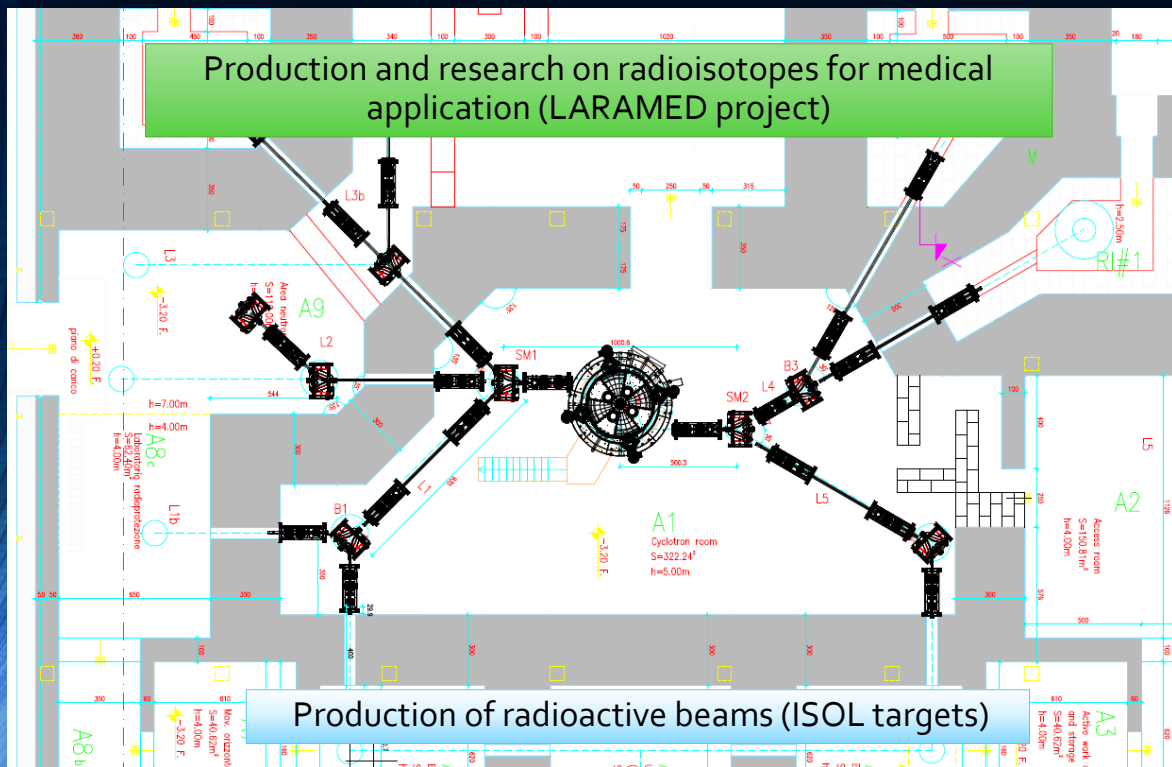

- Up to 9 irradiation target points
- 2 ISOL target stations (A6, A4)
- 3 Shielded bunkers (RI #1, #2, #3) for High Intensity irradiation
- 4 medium and low intensity target areas (A8, A9, A15)

High Intensity Proton Beam Facility for SPES

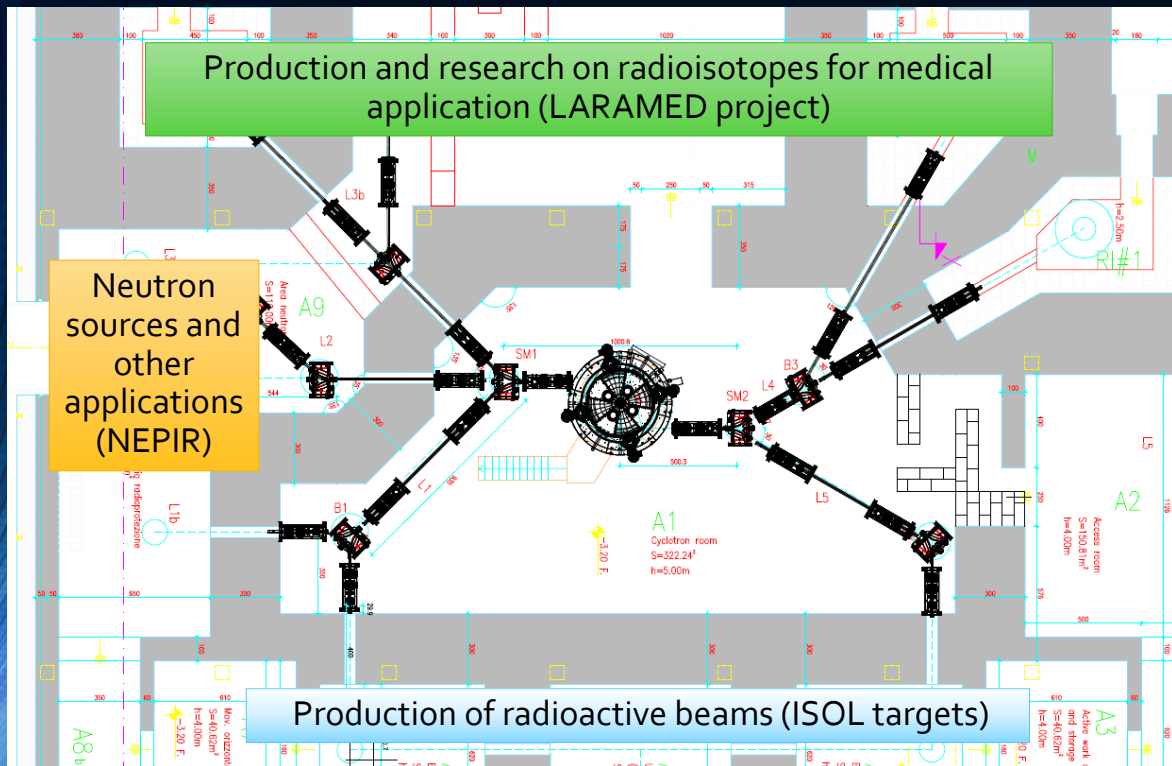

- Up to 9 irradiation target points
- 2 ISOL target stations (A6, A4)
- 3 Shielded bunkers (RI #1, #2, #3) for High Intensity irradiation
- 4 medium and low intensity target areas (A8, A9, A15)

The 70 MeV Cyclotron



Vacuum system \rightarrow 4 cryopumps \rightarrow 5×10^{-8} torr (beam OFF)

Main Parameters	
Accelerator type	Cyclotron AVF with 4 sectors, Resistive Magnet
Particle	Protons (H^+ accelerated)
Energy range	35-70 MeV
Max Current Intensity	700 μA (variable within the range $1\mu A$ -700 μA)
Extraction	Dual stripping extraction
Max Magnetic Field	1.6 T ($B_0 = 1$ T)
RF System	nr. 2 delta cavities; harmonic mode=4; $f_{RF} = 56$ MHz; 70 kV peak voltage; 50 kW RF power (2 RF amplifiers)
Ion Source	Multi-cusp volume H^+ source; $I_{ext} = 8$ mA; $V_{ext} = 40$ kV; axial injection
Dimensions	$\Phi = 4.5$ m, $h = 2$ m, $W = 190$ tons

Cyclotron story: it began in 2010 (contract signed with Best Ther.)



2011-2014 Study,
Design ,Construction
and factory tests

Cyclotron story: it began in 2010 (contract signed with Best Ther.)



2011-2014 Study,
Design ,Construction
and factory tests



2015
Installation at LNL

Cyclotron story: it began in 2010 (contract signed with Best Ther.)



2011-2014 Study,
Design, Construction
and factory tests



2015
Installation at LNL



2016
First beam and
commissioning

Cyclotron story: it began in 2010 (contract signed with Best Ther.)



2011-2014 Study,
Design, Construction
and factory tests

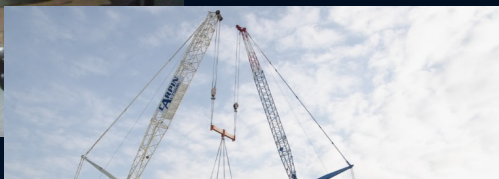

2015
Installation at LNL



2016
First beam and
commissioning

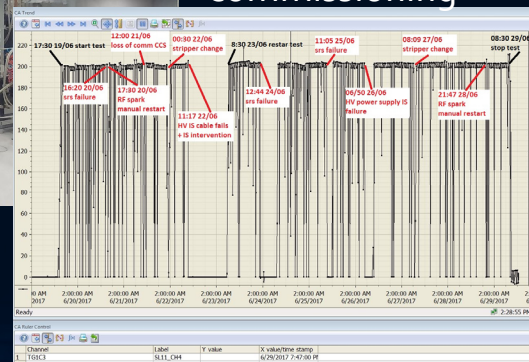

2017
Site Acceptance
Test and supply
delivered

2018
INFN operation

Endurance test

- Final SAT
- 5 days operation 24h
- 200 μ A and 40 MeV (SPES target beam parameter)
- Limited number of interventions by the operator
- Automatic procedure to restore the beam after any trip due to accidental sparks (inflexor, ion source, RF)

Test passed successfully
in June 2017 and FAT
concluded

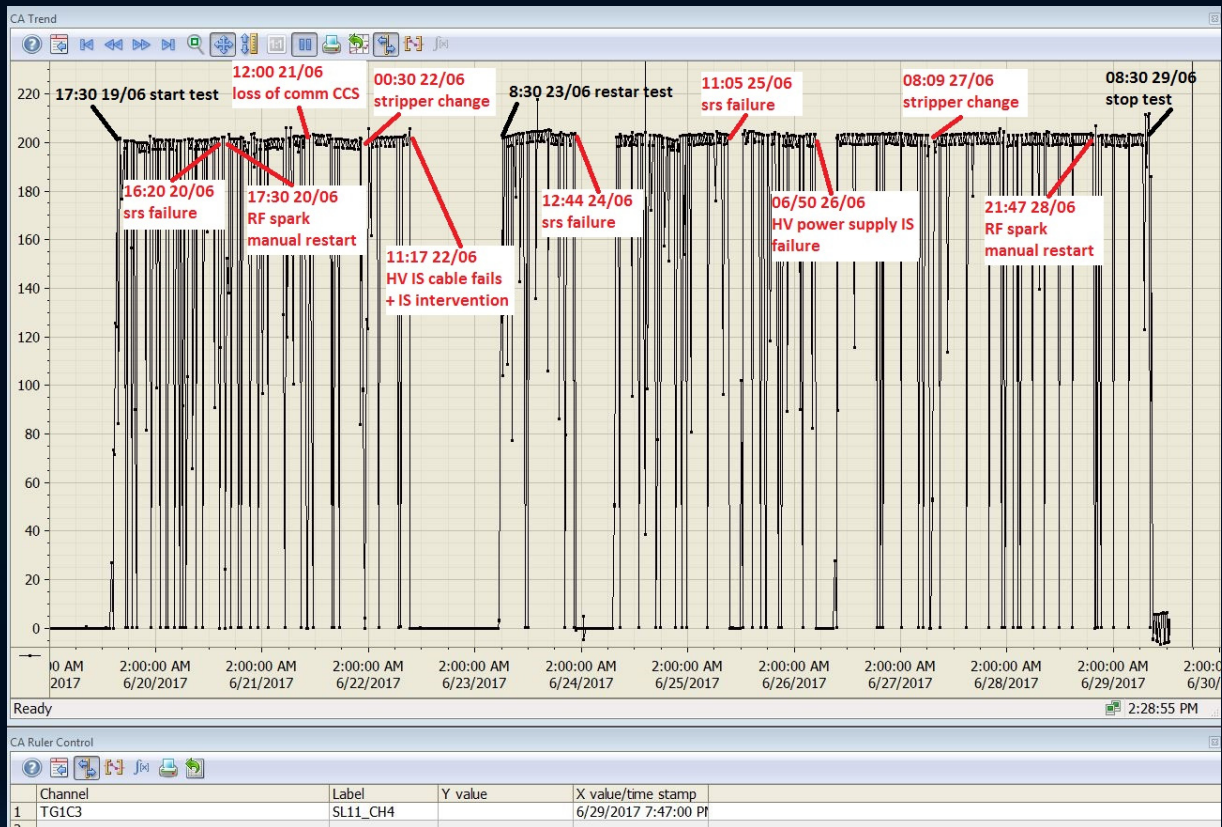

Statistics from data analysis

Total acquisition time: 5 days

The total beam uptime is: 4.5 days of 5.0 days.
The total beam uptime is: 90.7 % of total time

The average value of current is: $201.17 \pm 0.97 \mu\text{A}$
There are: 108 beam trips (~ 1 trip/hr average)

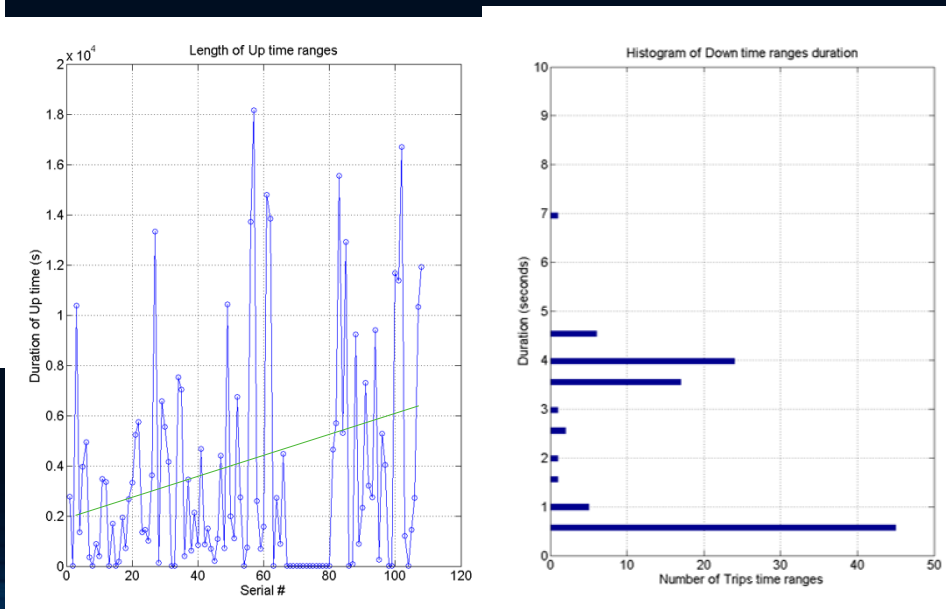
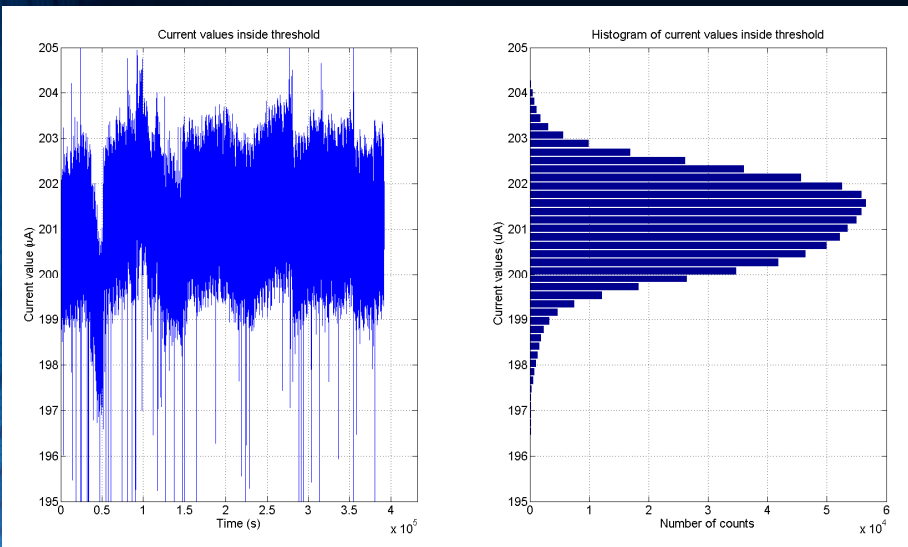

Beam trips source

- HV ion source sparks → automatic beam recovery → fastest (< 1 sec)
→ almost 50% of total beam trips (this issue has been improved by cleaning the IS electrodes)
- HV inflector sparks → automatic beam recovery → it needs 5 sec because of open/close injection gate valve and in/out beam stopper
→ $< 10\%$ of total beam trips
- RF cavity sparks → automatic beam recovery → it needs 5 sec because of open/close injection gate valve and in/out beam stopper
→ almost 40% of total beam trips

Neutron dose-rate during endurance test: stripper performance

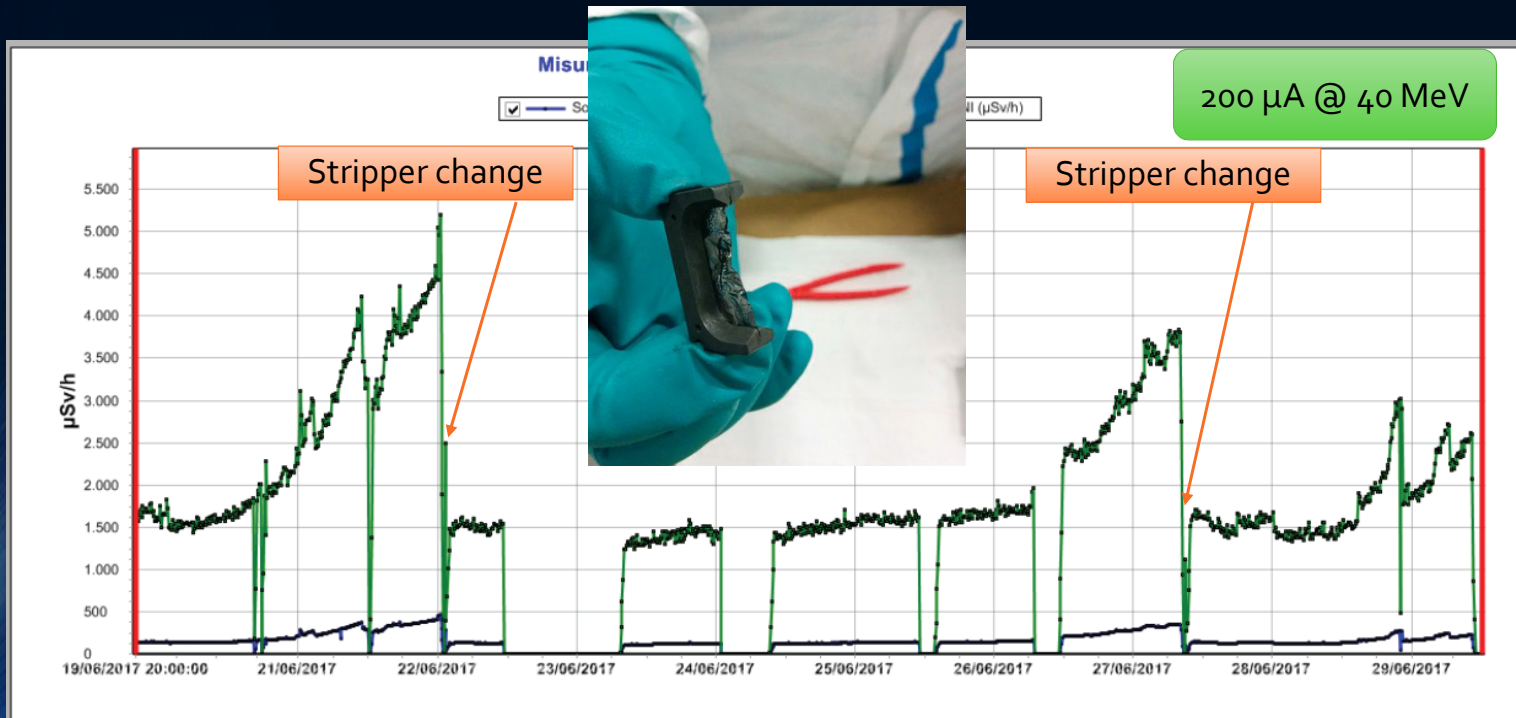

High intensity beam operation

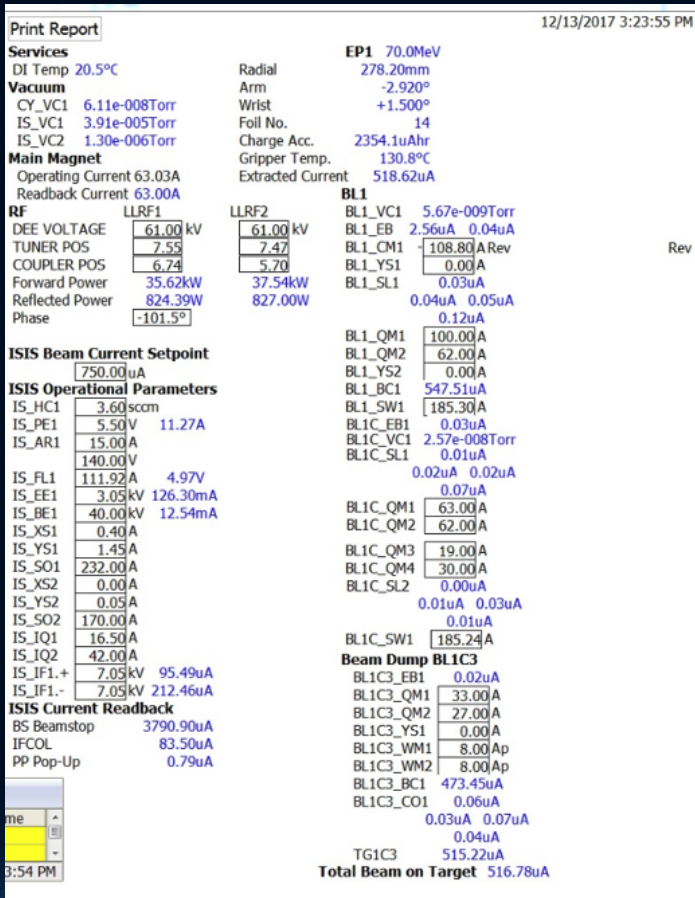
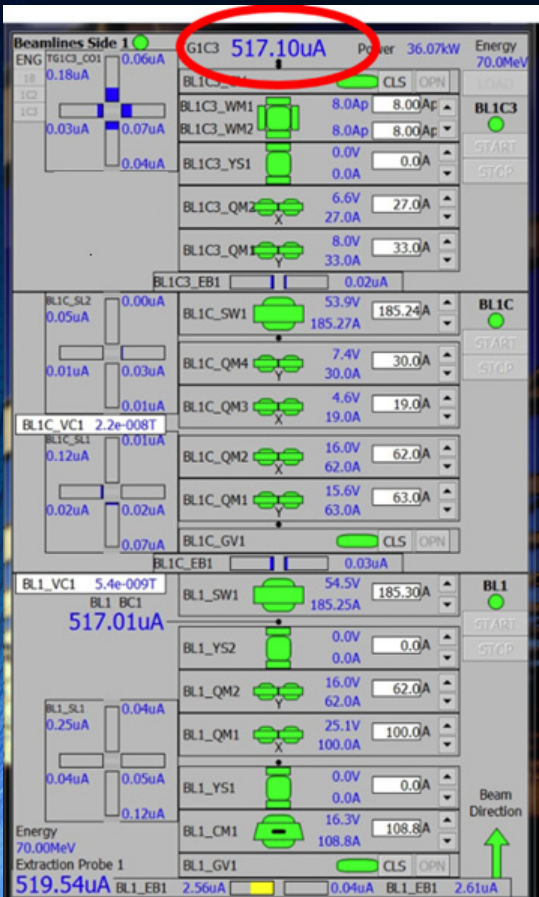

Vacuum Performance with beam ON:
 Cyclotron → 8.1×10^{-8} mbar
 Beamlines → $7.2 \times 10^{-9} \div 2.9 \times 10^{-8}$ mbar
 BD → 6×10^{-6} mbar

High intensity beam operation

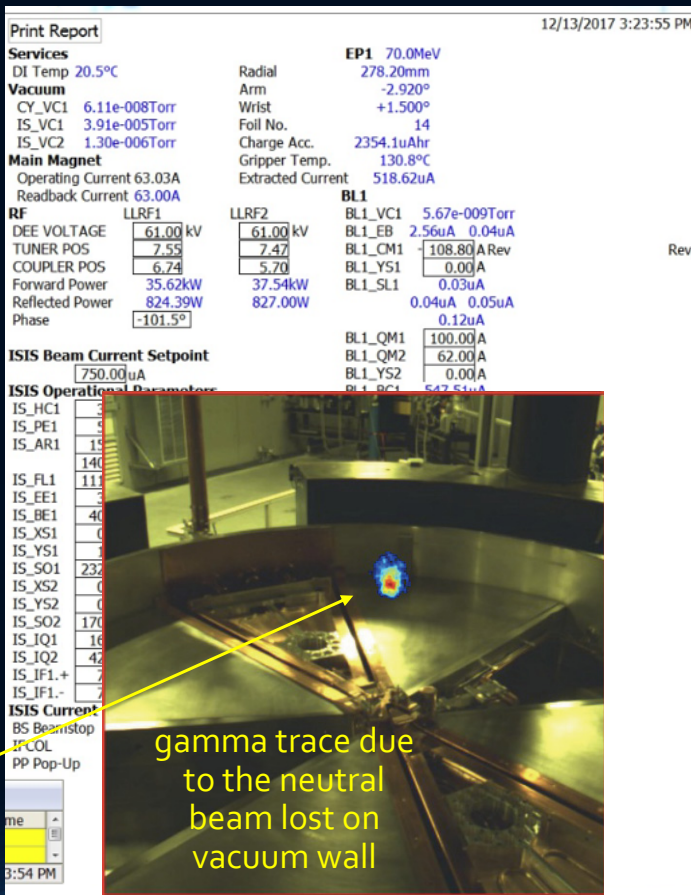
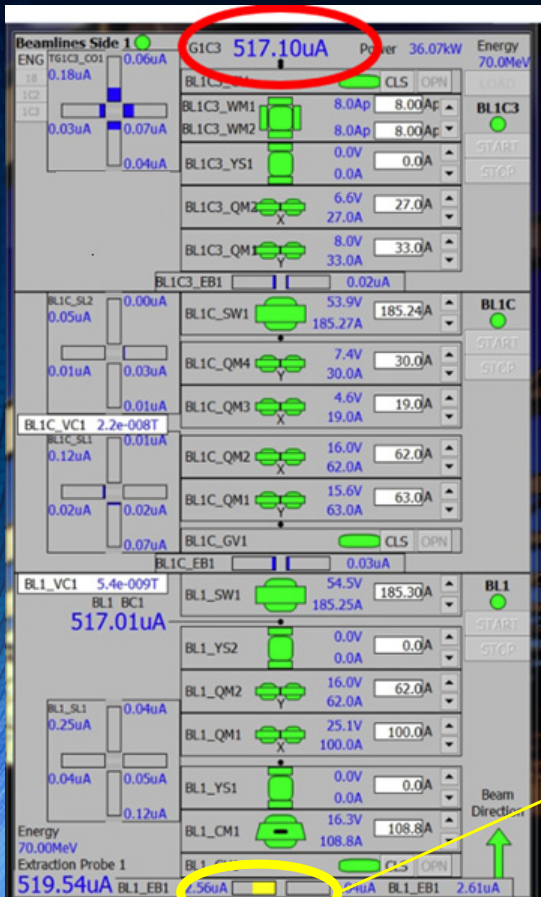

Vacuum Performance with beam ON:

Cyclotron → 8.1×10^{-8} mbar

Beamlines → 7.2×10^{-9} ÷ 2.9×10^{-8} mbar

BD → 6×10^{-6} mbar

Intensity ramp-up → beam stability improvements

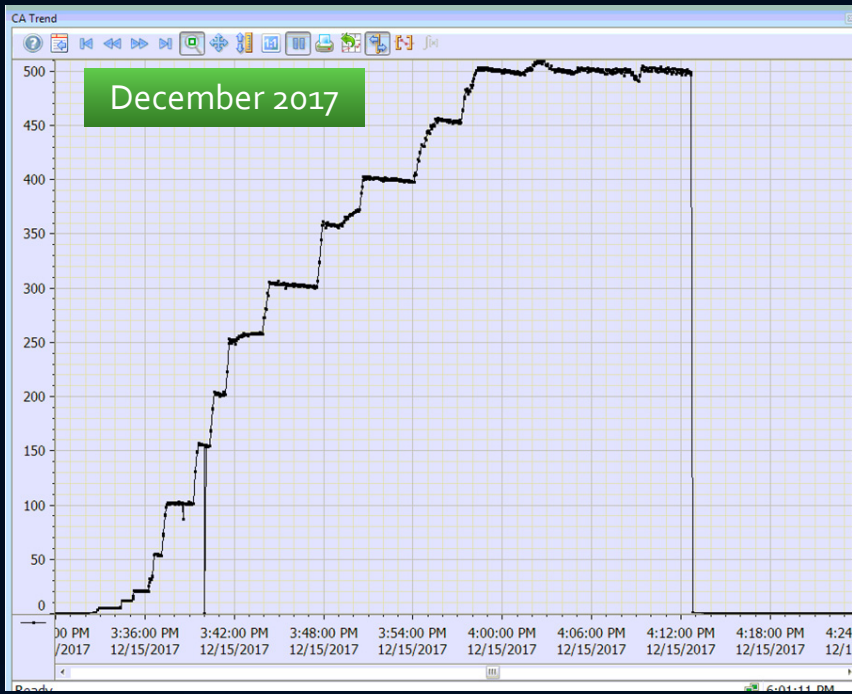
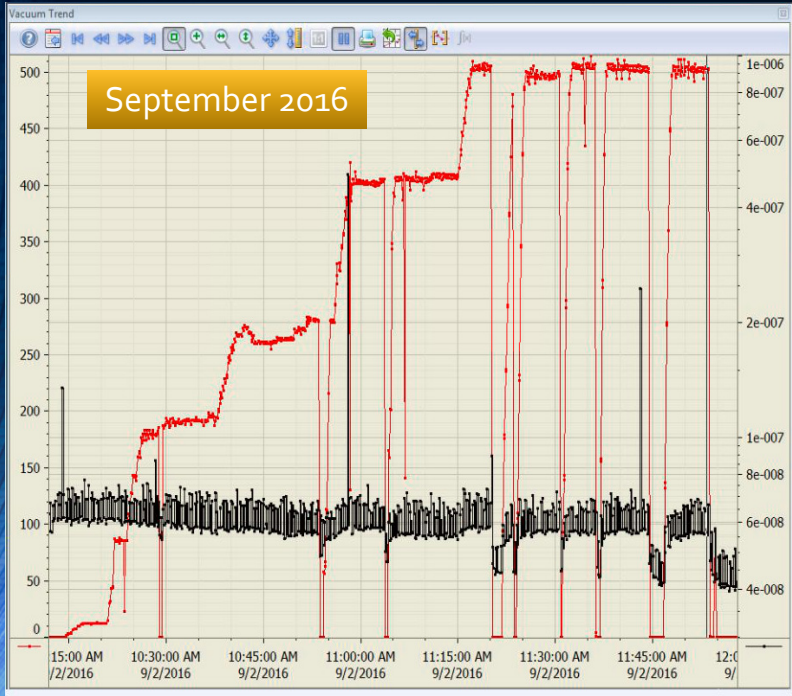

Beam transport at high current ($500\mu\text{A}$ @70 MeV)

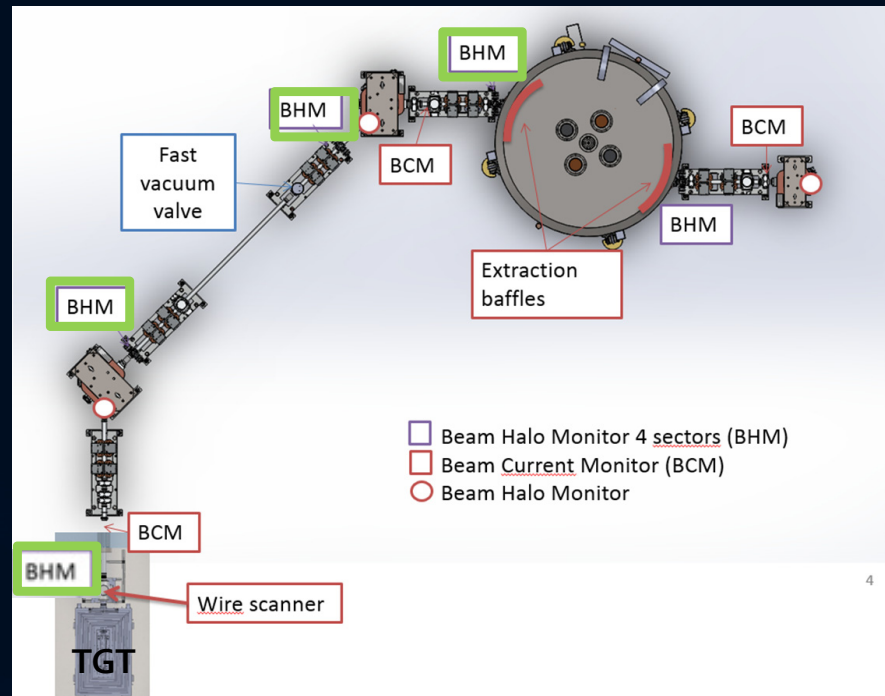
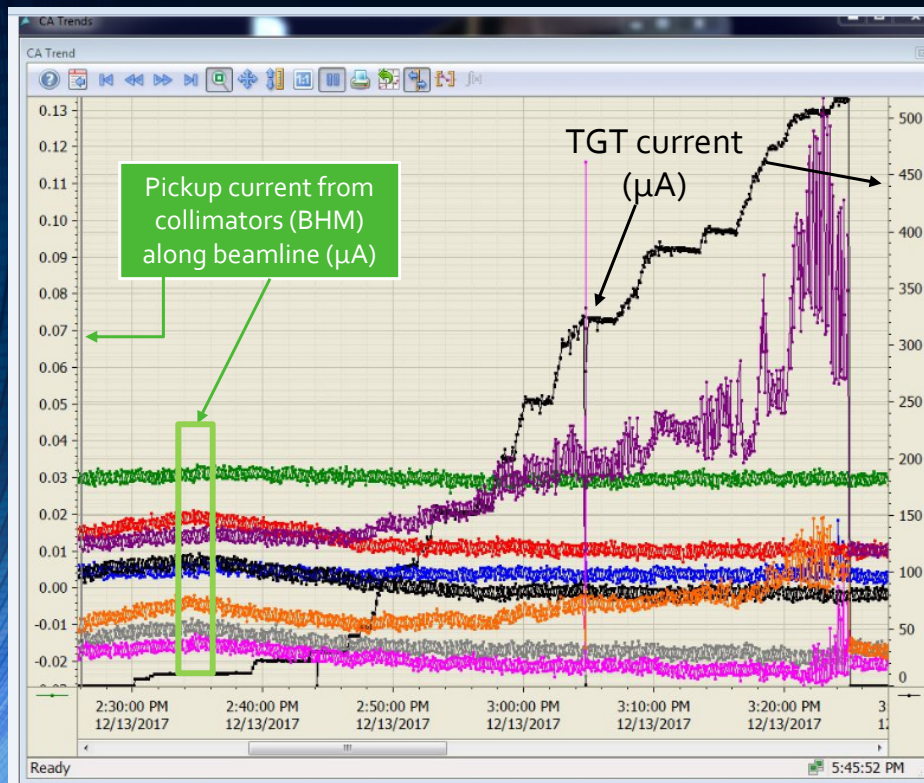

Beam transport at high current ($500\mu\text{A}$ @70 MeV)

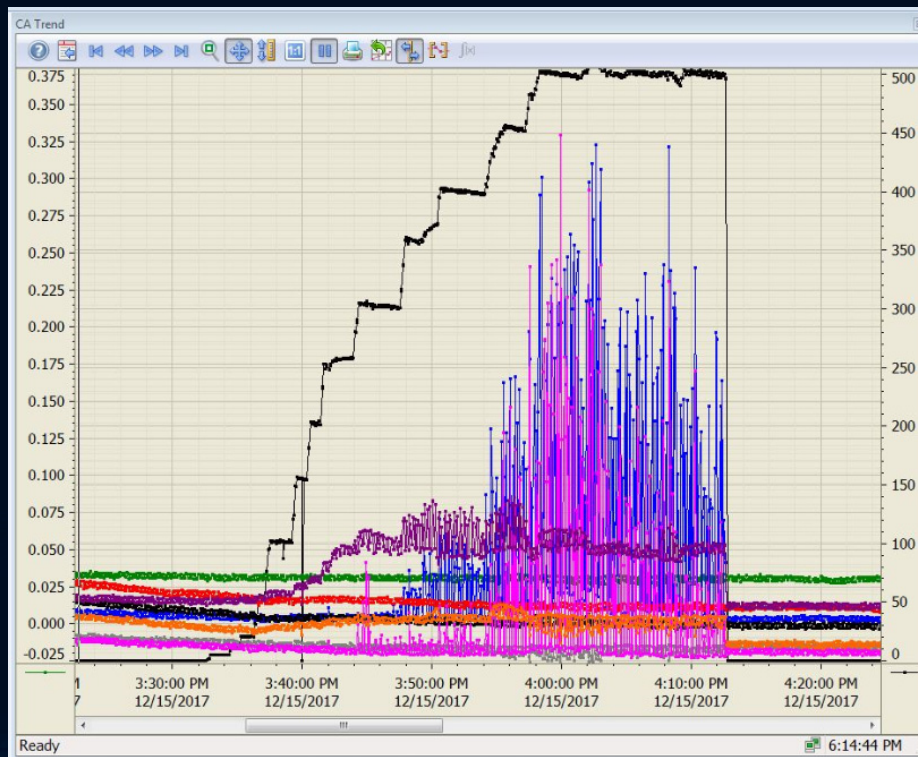
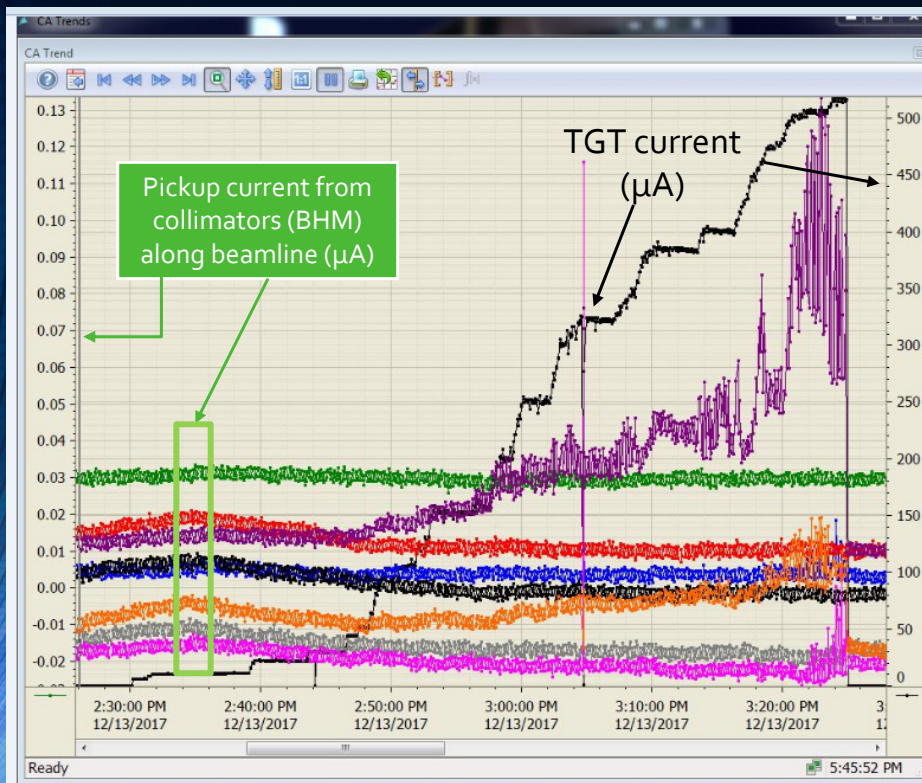

Beam losses monitoring by the Radiation Survey System

70 MeV 100 μ A thru BL1 to BD

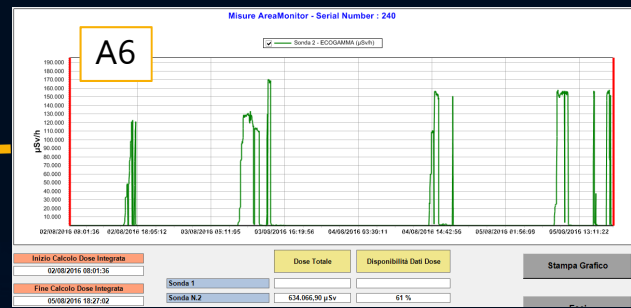
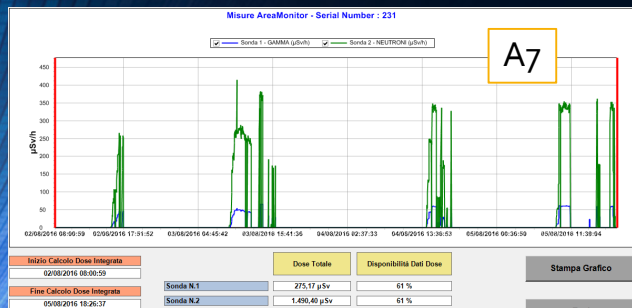
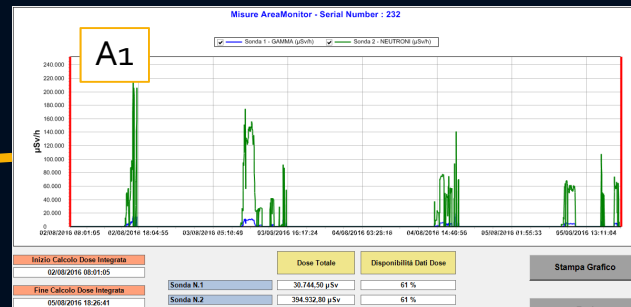
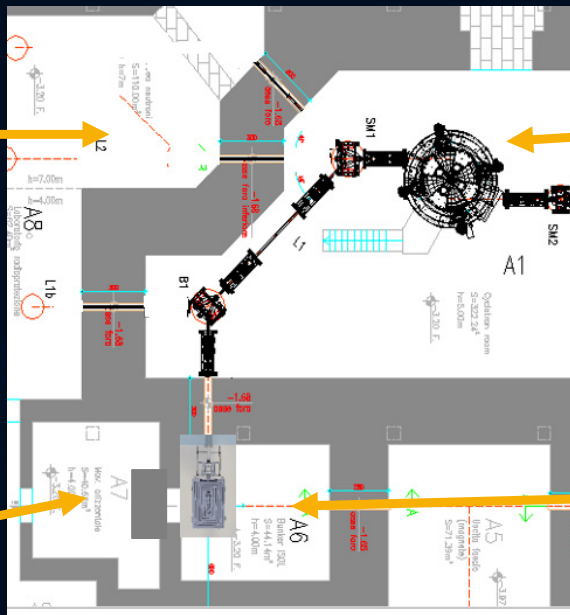
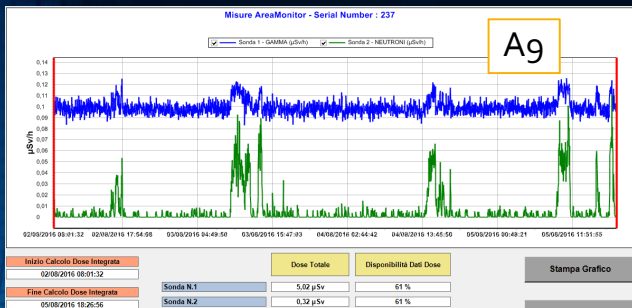

Beam losses monitoring by the Radiation Survey System

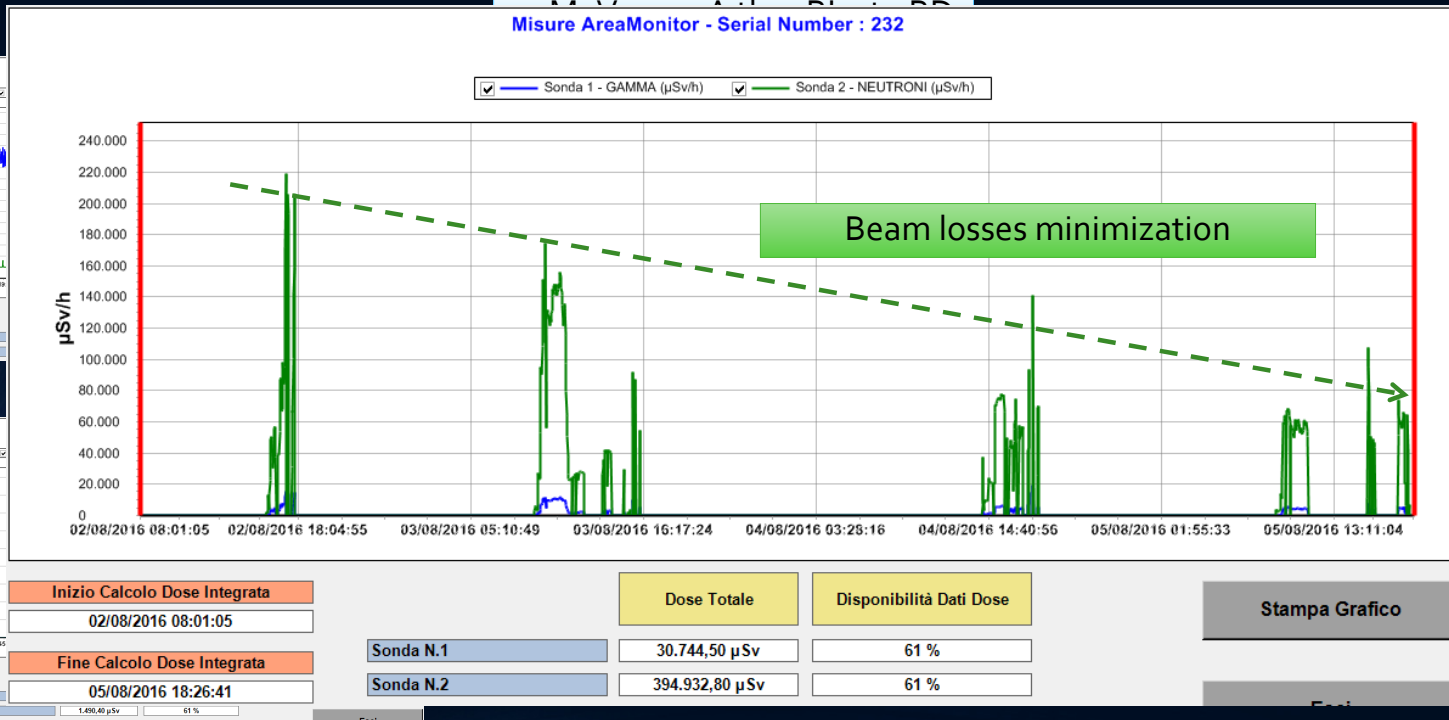

Radiation Survey Overview

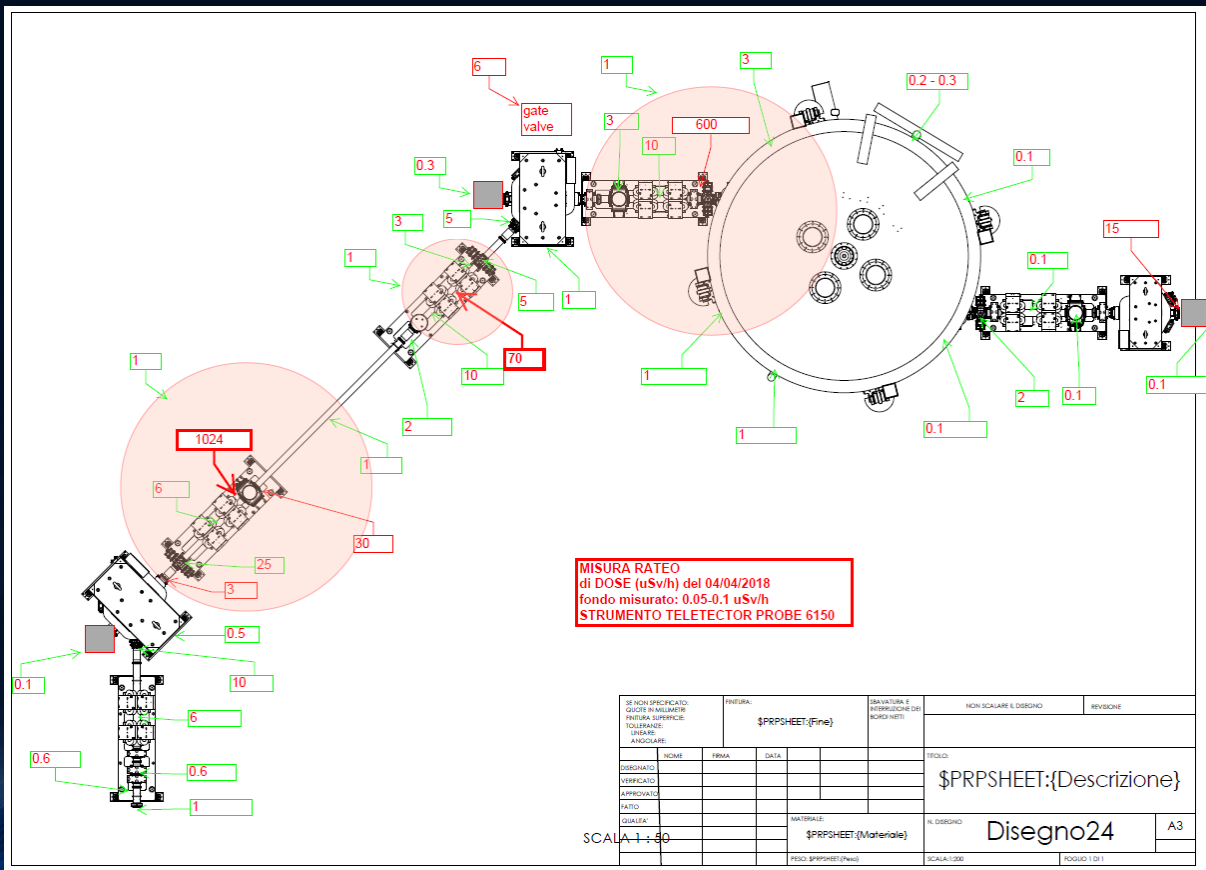

Diagnostics and beam optics check

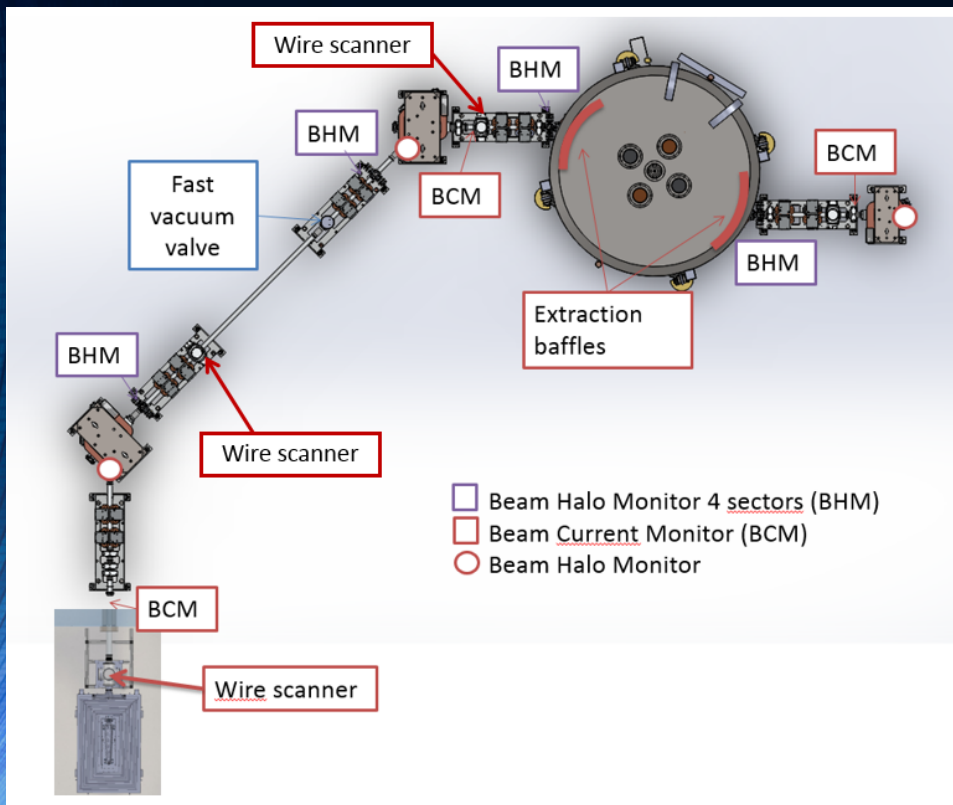

TRACEWIN beam optics calculation

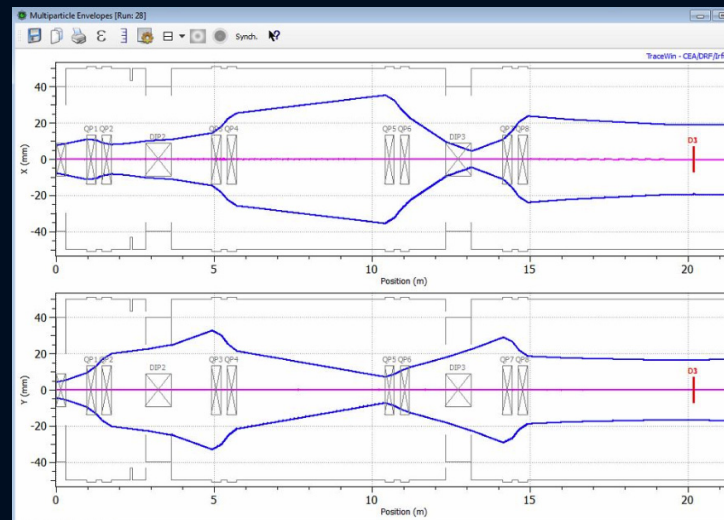

Diagnostics and beam optics check

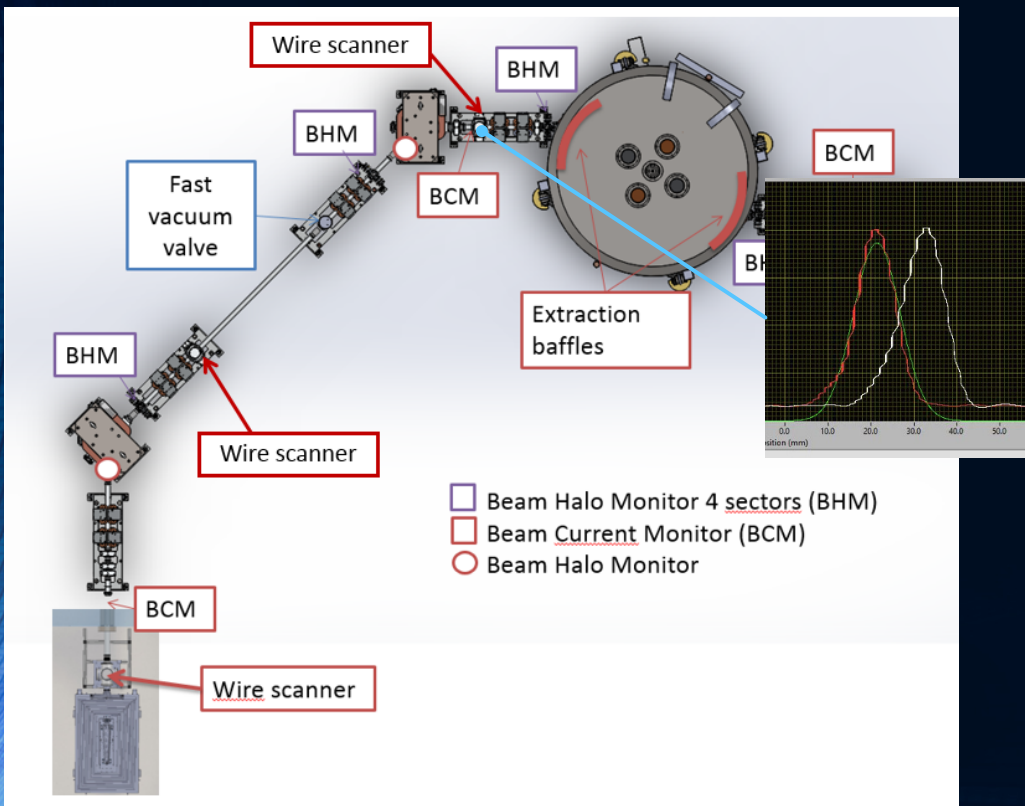

TRACEWIN beam optics calculation

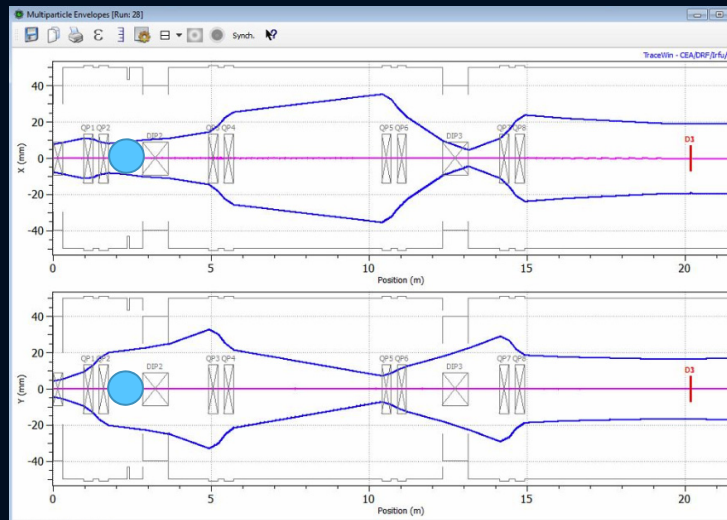

Diagnostics and beam optics check

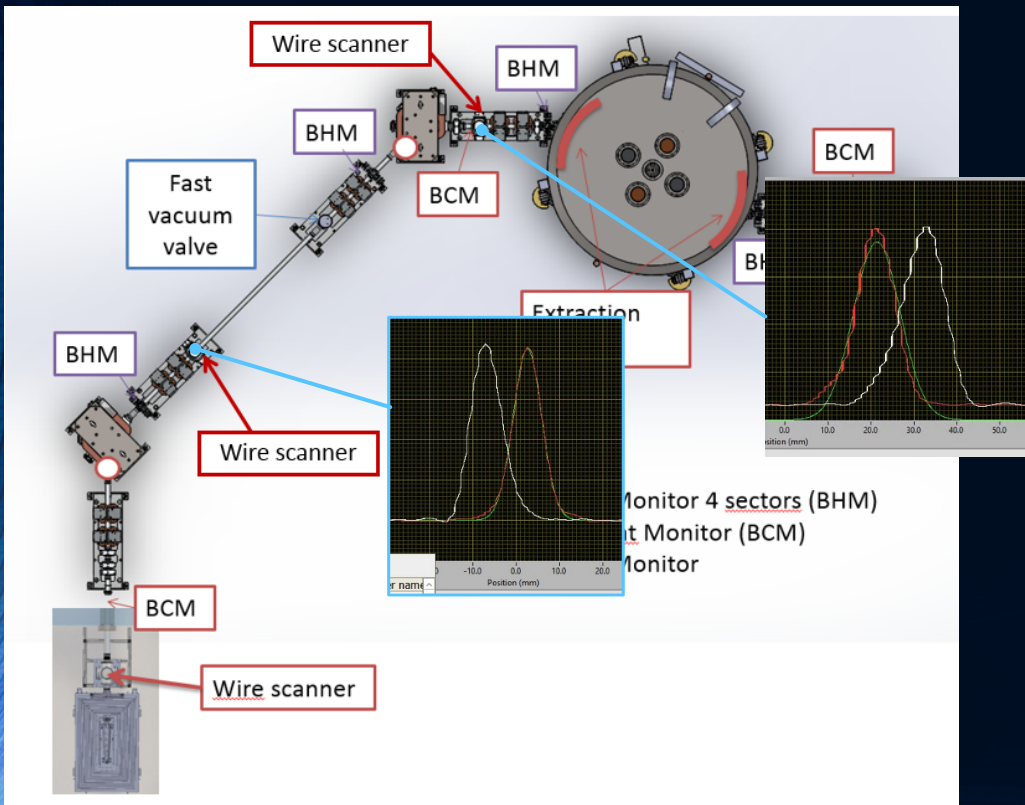

TRACEWIN beam optics calculation

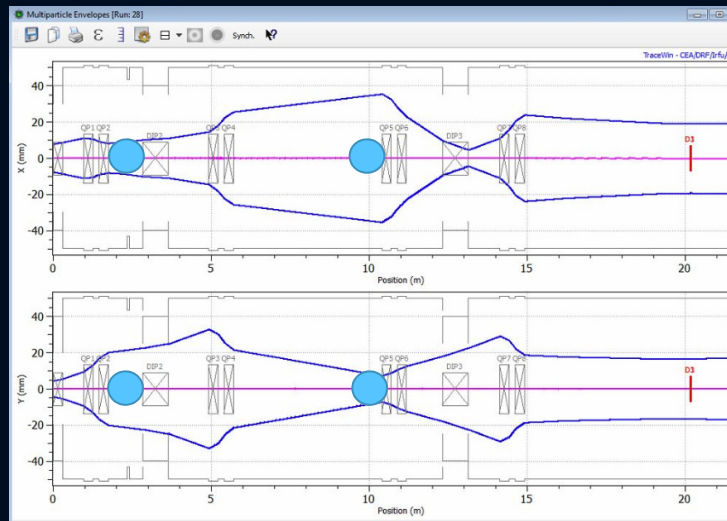

Diagnostics and beam optics check

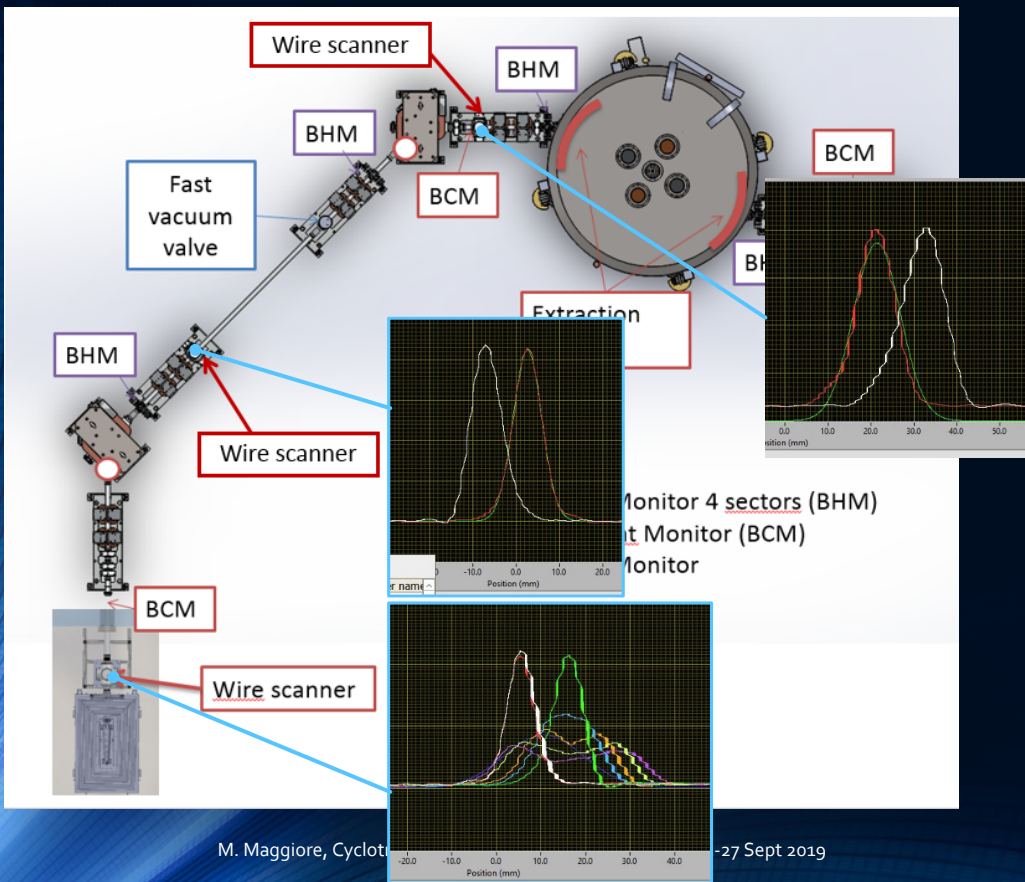

TRACEWIN beam optics calculation

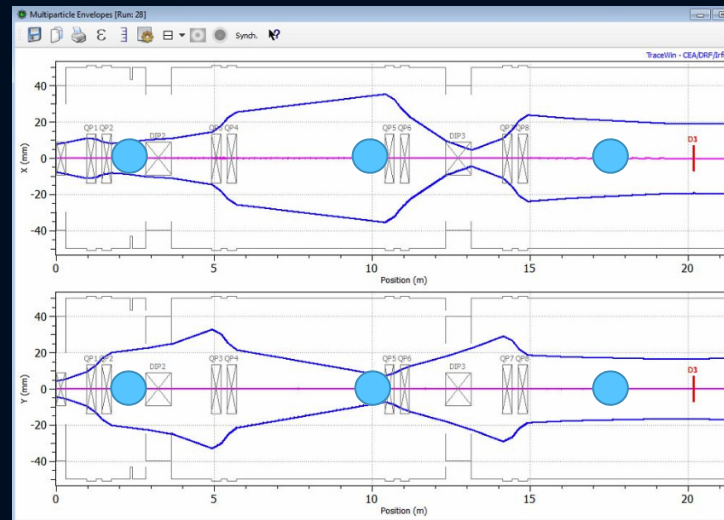

Diagnostics and beam optics check

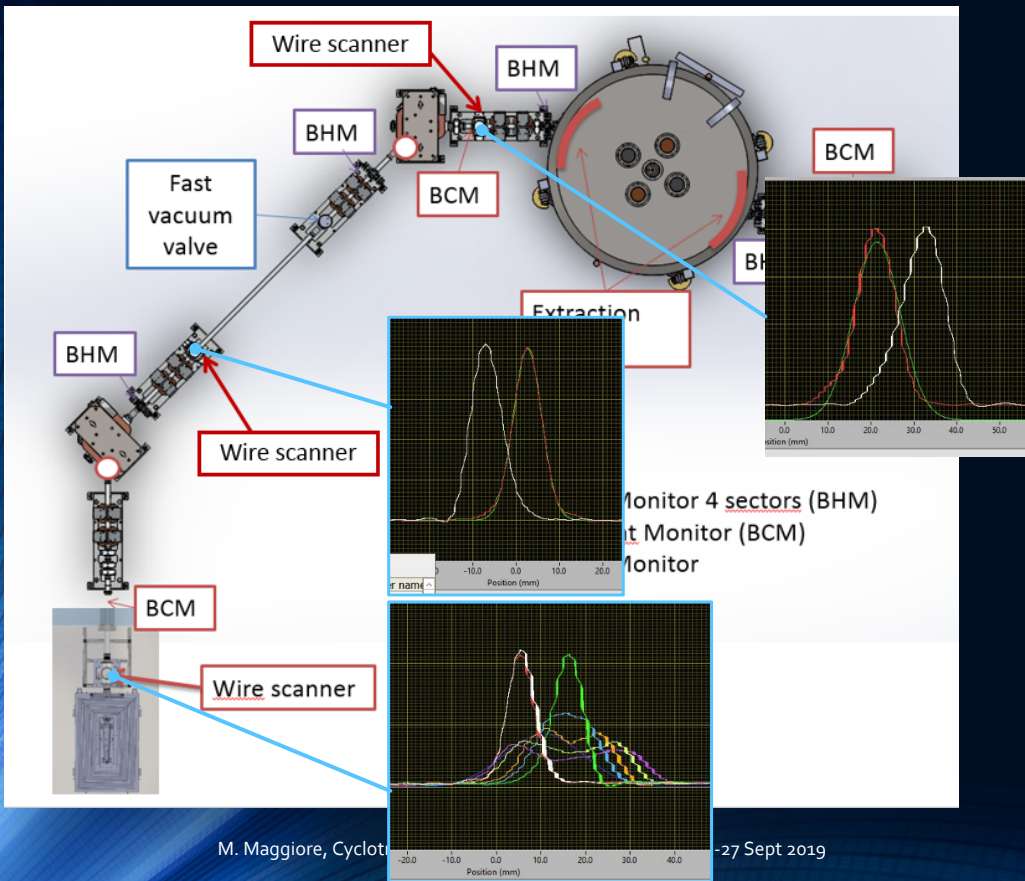

TRACEWIN beam optics calculation

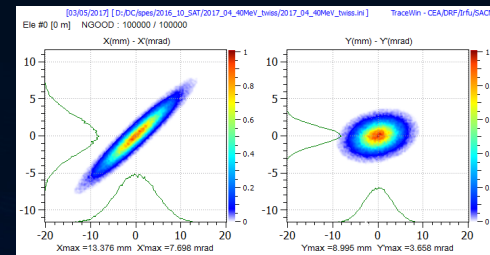
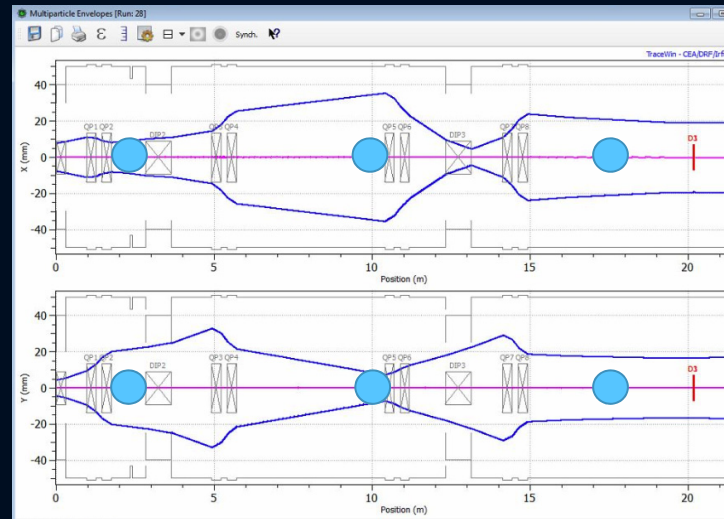

Beam operations: preliminary considerations

- High power beam is delivered with good reproducibility and satisfactory stability. Very demanding for operators to transport more than 20 kW of beam power. More time for training to gain experience is needed!!
- Dual extraction allows to spill from one extraction port up to **20 nA** (lowest limit) of current beam (extracting 5 μA from the other side) \rightarrow very precise and accurate radial mechanical movement of stripper foil (μm step motor)
- Good agreement with the beam optic calculation done with Tracewin code \rightarrow good matching with determination of beam size at different points along the beamline
- Very good feedback from neutron monitors to optimize the transport of the beam by keeping low the losses

Cyclotron team activity: maintenance

- Cryopumps and He gas lines and compressors
- RF power amplifier #2 retuning
- Vacuum gauges calibration
- Cyclotron hydraulic system purge and oil replacing
- Control System bugs fixing
- H₂ gas circuit to be connected to the IS
- DI package resin to be replaced
- IS cleaning



Cyclotron team activity (cont'd)

- ISOL₂ and LARAMED beamline installation (BEST Theratr.)
- Laser track alignment
- Cooling system and cryogenics lines
- Electrical power and signals cabling
- Emittance measurements setup preparation

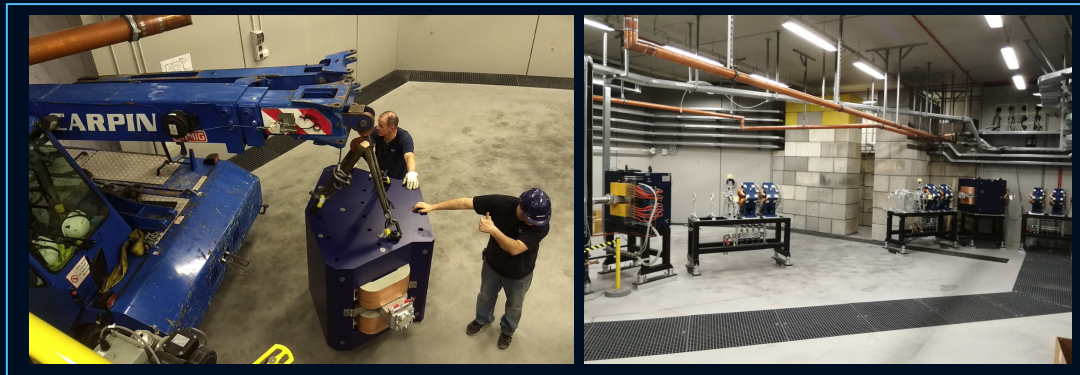

M. Maggiore, Cyclotrons 2019, Cape Town (South Africa), 22-27 Sept 2019

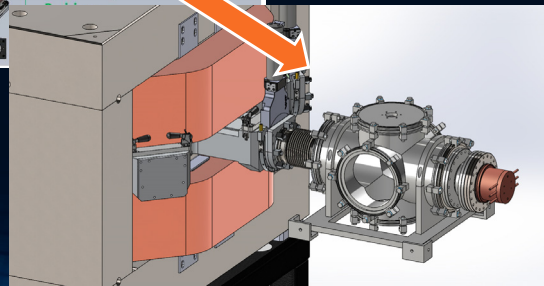
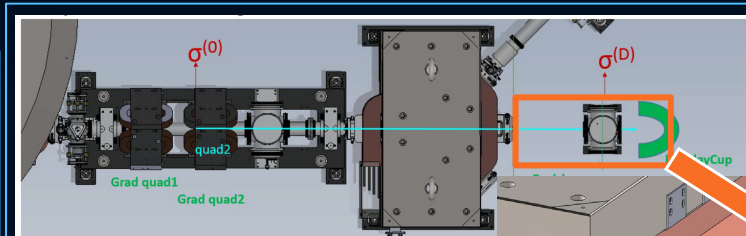

New beam wire scanner

Single Arm Model 1

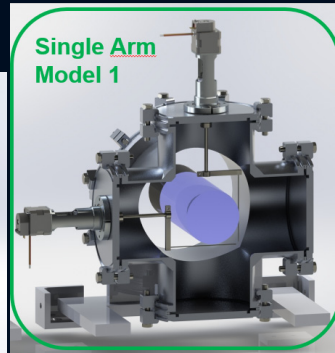

New upgrade Cyclotron systems

- New skids for water cooling of beamlines, cyclotron, RF system, activated FCs and collimators
- Collimator with variable size shall be installed along the IL to control the average beam current extracted from the cyclotron
- Buncher system is under study
- New high power beam dump for cyclotron tests

Iris diaphragm (6 sectors) aperture

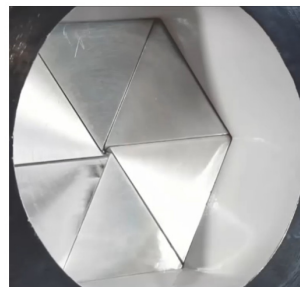

- 1 - Compact Design
- 2 - Water Cooled
- 3 - Single actuator
- 4 - Remote controlled
- 5 - Easy Replacement

Materials: Copper (cooled), Graphite (not Cooled).
Processing: Machined (Both), Sintering (Graphite), 3D Printing (Copper)

4. Design of the Beam Dumper

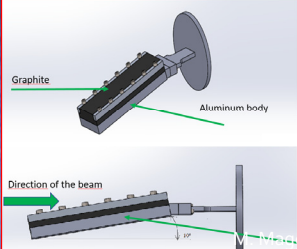

- Designed to fit inside of the beam line with diameter of 150 mm
- Maximum delivered power of ~50 kW
- Dimensions of the Graphite plate 80 mm x 220 mm x 22 mm
- Exposed area which will stop the beam of 176 cm²
- Plate is positioned on 10° angle
- Calculated mass of 1.4 kg
- Water cooling channels inside the aluminum body. Temperature of water 15°C down to 5°C and speed of 0.3 m/s.

6. Activation and residual dose rate calculations

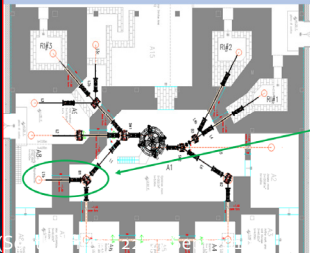

- The geometry and design and the position of the dumper and drawn into the Eluka software.
- The cyclotron is positioned in bunker A1 while the dumper is positioned in the hole that connects bunker A1 and A9.
- The Beam Dumper is positioned inside the hall of the wall between A1 and A9.
- Maximum beam energy of 70 MeV
- Maximum beam current of 750 μA
- Total power of ~50 kW.
- Irradiation time, 5 hours per day in period of two weeks.

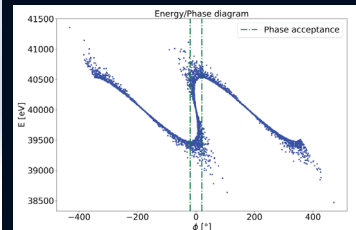
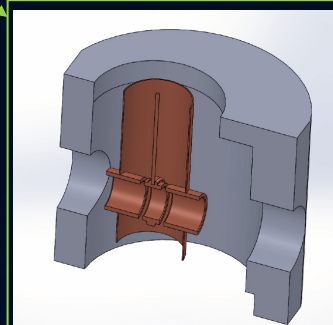

Extension plan of high intensity facility

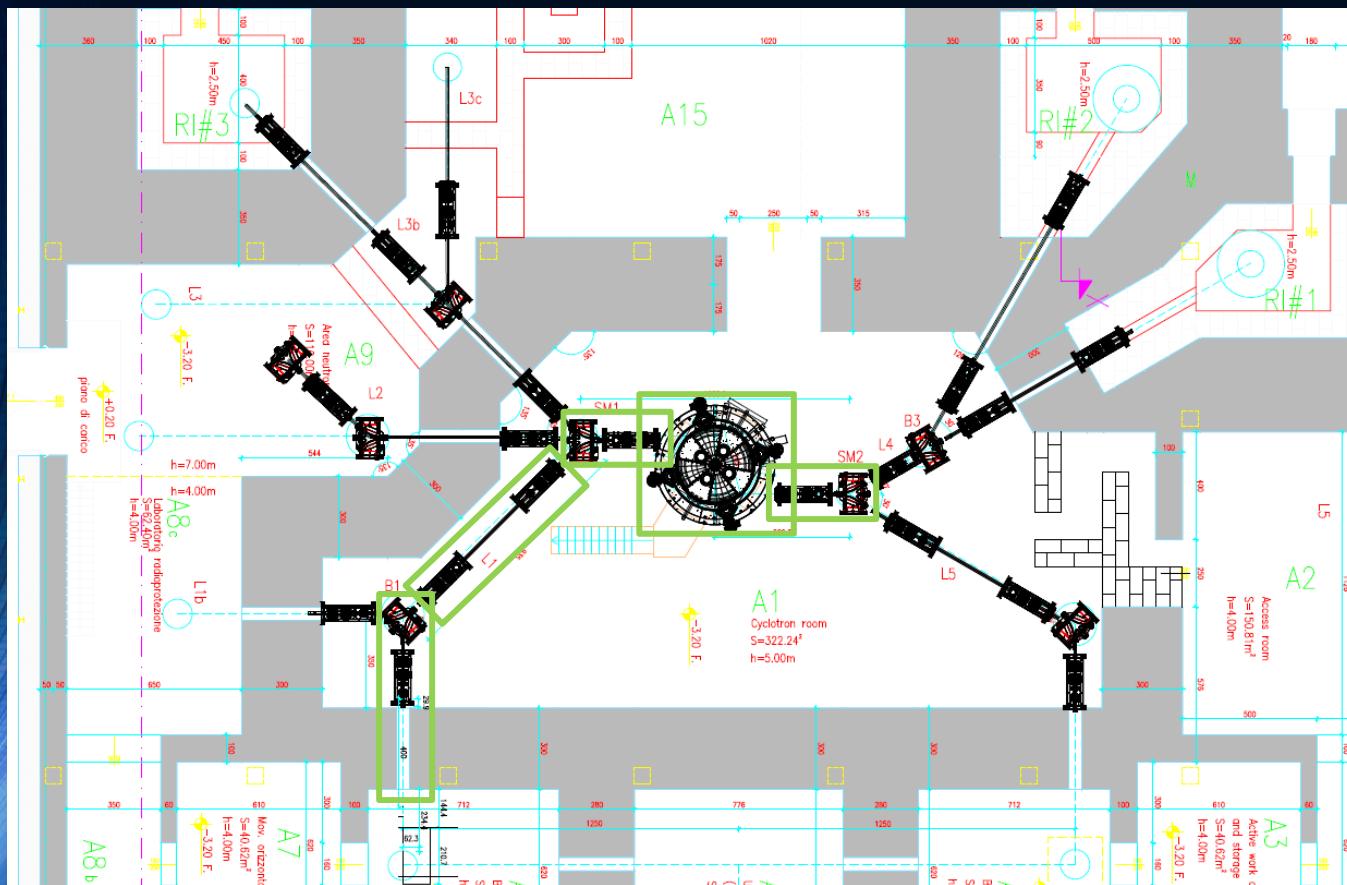

Actual Installation:
Cyclotron and BL₁, BL₂
lines

Extension plan of high intensity facility

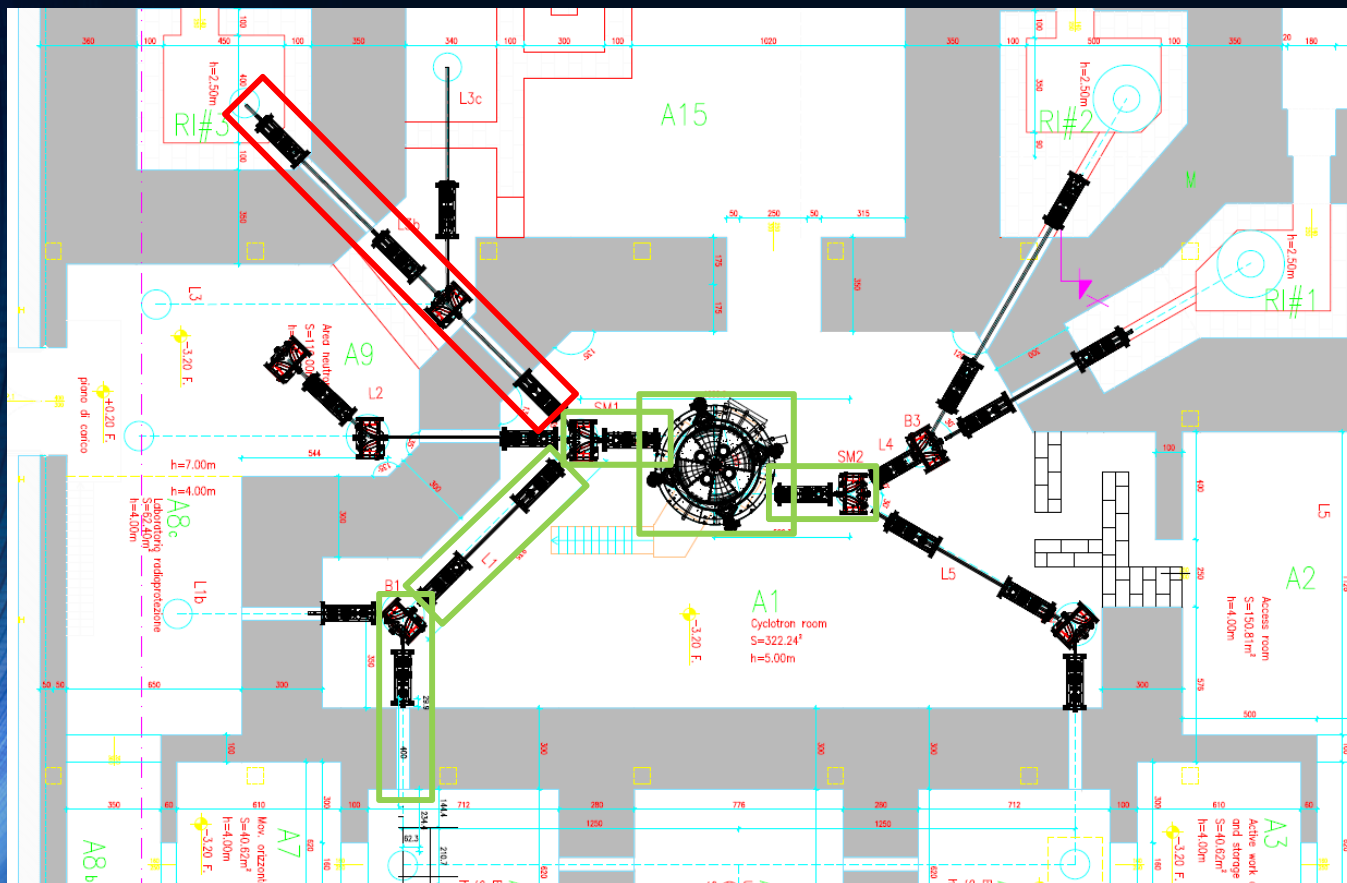

Extension plan of high intensity facility

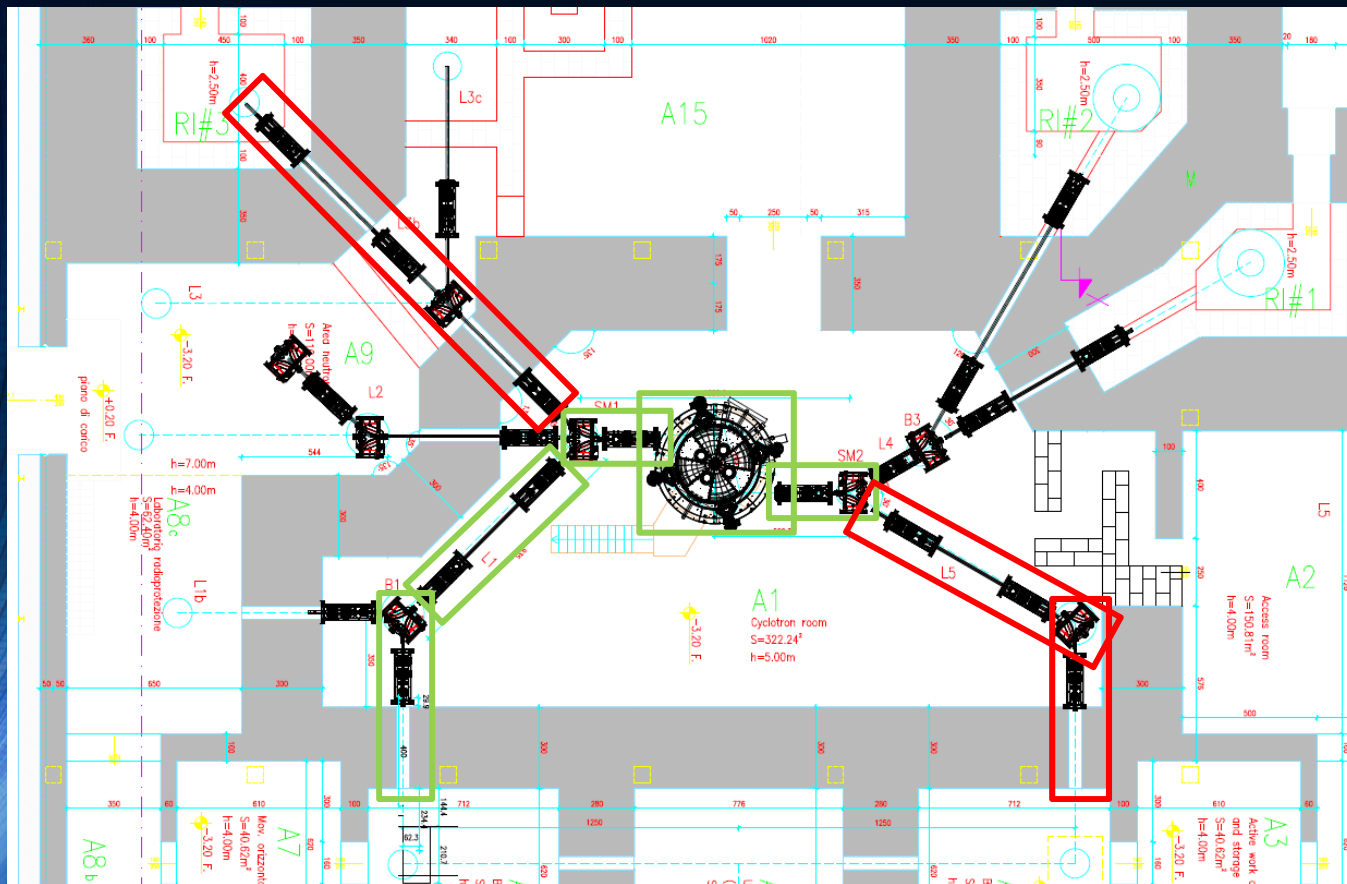

Actual Installation:
Cyclotron and BL₁, BL₂
lines

LARAMED (high power
beam: 30-70 MeV, 10uA):
Installation expected in
2020

ISOL 2 beamline
Installation expected by
December 2019

Extension plan of high intensity facility

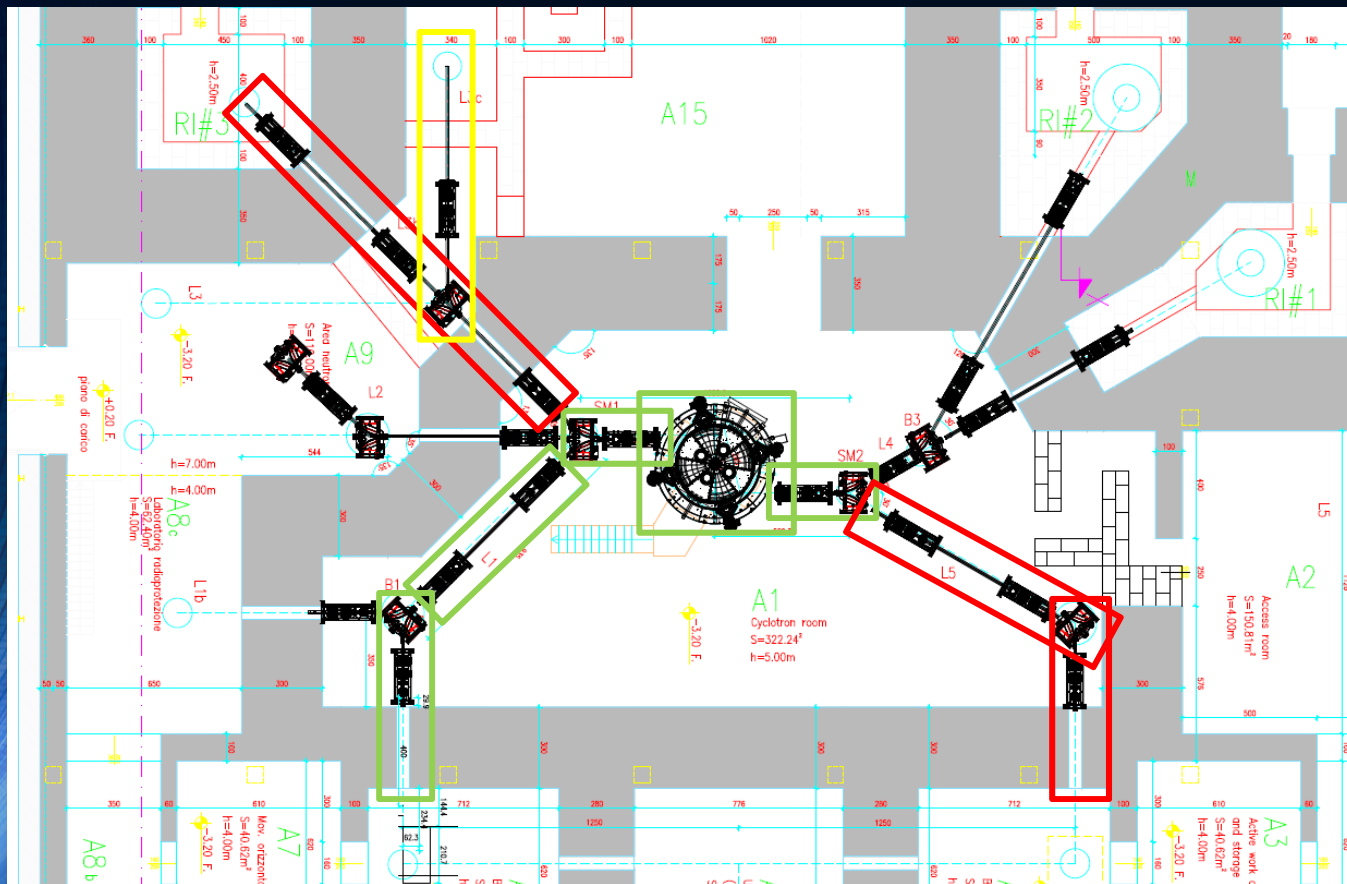

Actual Installation:
Cyclotron and BL₁, BL₂
lines

LARAMED (high power
beam: 30-70 MeV, 10uA):
Installation expected in
2020

ISOL 2 beamline
Installation expected by
December 2019

LARAMED (low power:
30-70 MeV, 200 nA):
beamline BL_{3c} under
design, tender by
December 2019,
installation in 2021

Conclusions

- The high intensity facility whose core is the cyclotron is now operational at LNL:
 - The commissioning of cyclotron supplied by BEST was accomplished out in 2017.
 - Beam operations were done in 2018 by INFN staff in order to test the capability and full performance of the machine.
- The machine achieved $500 \mu\text{A}$ (35kW) and only a small vacuum leak of Beam Dump occurred at high power did not allow to overcome that limit. Anyway tests show very good performance in terms of vacuum level, acceleration efficiency and transmission as well.
- In May 2018, the cyclotron was turned off to allow the installation of SPES equipment and proceed with the completion of the facility (new control access system, plants upgrading). Two ancillary projects for applications of high intensity beam are carrying on: LARAMED is under installation and NEPIR under final design evaluation.
- The re-start of operations at low energy (1MeV) is expected by the end of 2019, and full energy beam operation by mid of 2020.

