



中国原子能科学研究院

中核集团 CHINA INSTITUTE OF ATOMIC ENERGY
CNNC

A New Solution for Cost Effective, High Average Power (2GeV, 6MW) Proton Accelerator and its R&D Activities

Dr Tianjue Zhang, China Institute of Atomical Energy
Cape Town, South Africa, 2019.09.27



1. 52 kW CW Proton Beam Production by CYCIAE-100

- a) Introduction about BRIF & First Proton Beam from CYCIAE-100
- b) 52 kW CW Proton Beam Production
- c) Dual Beam Extraction simultaneously for Multi-applications

2. General Design of High Power, High Energy Circular Accelerator (2GeV, 6MW)

- 1. General Consideration and Beam Dynamics
- 2. R&D for Key components (HT SC Magnet, HP RF System)

3. Other Cyclotron Activities for Medical Applications & more (If I still have time)



35 km from Tiananmen Square

CIAE is one of the biggest, important institute in China. But it may not a well-known institute in the academic community for some reasons. *Please let me introduce CIAE a few slides.*

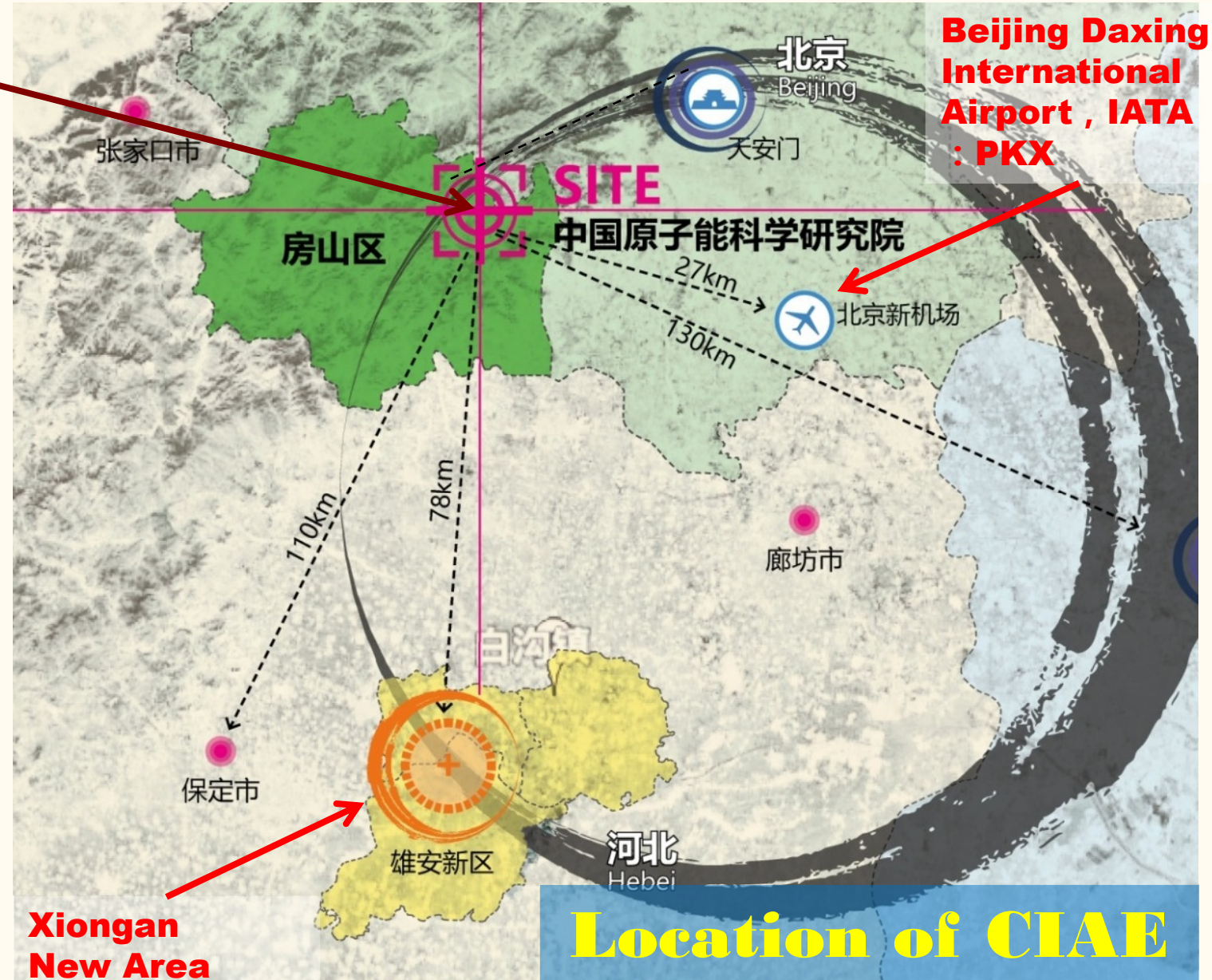

**35 km from
Tiananmen Square**

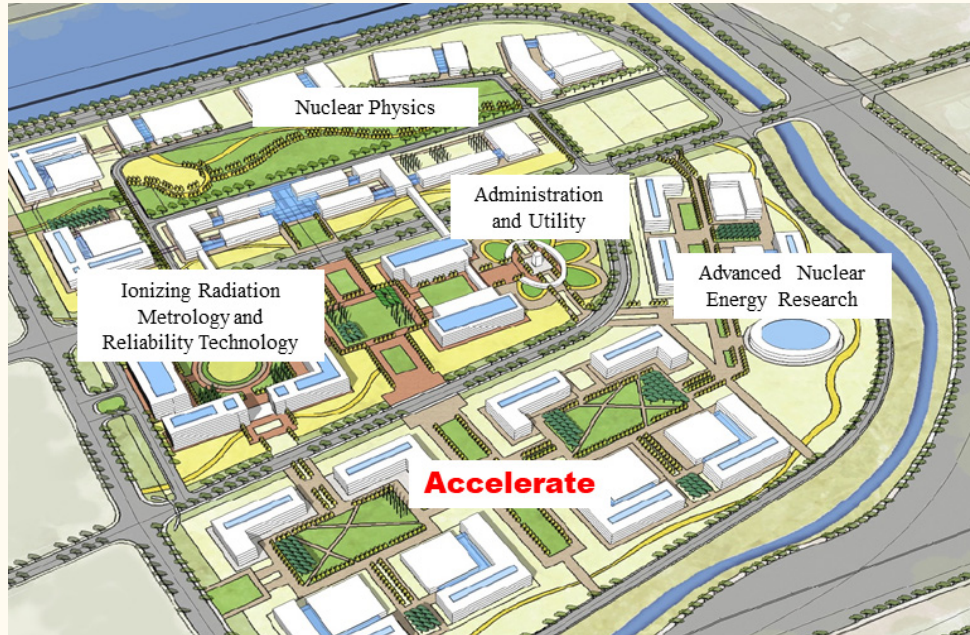

2nd CIAE Site

1000,000 m²

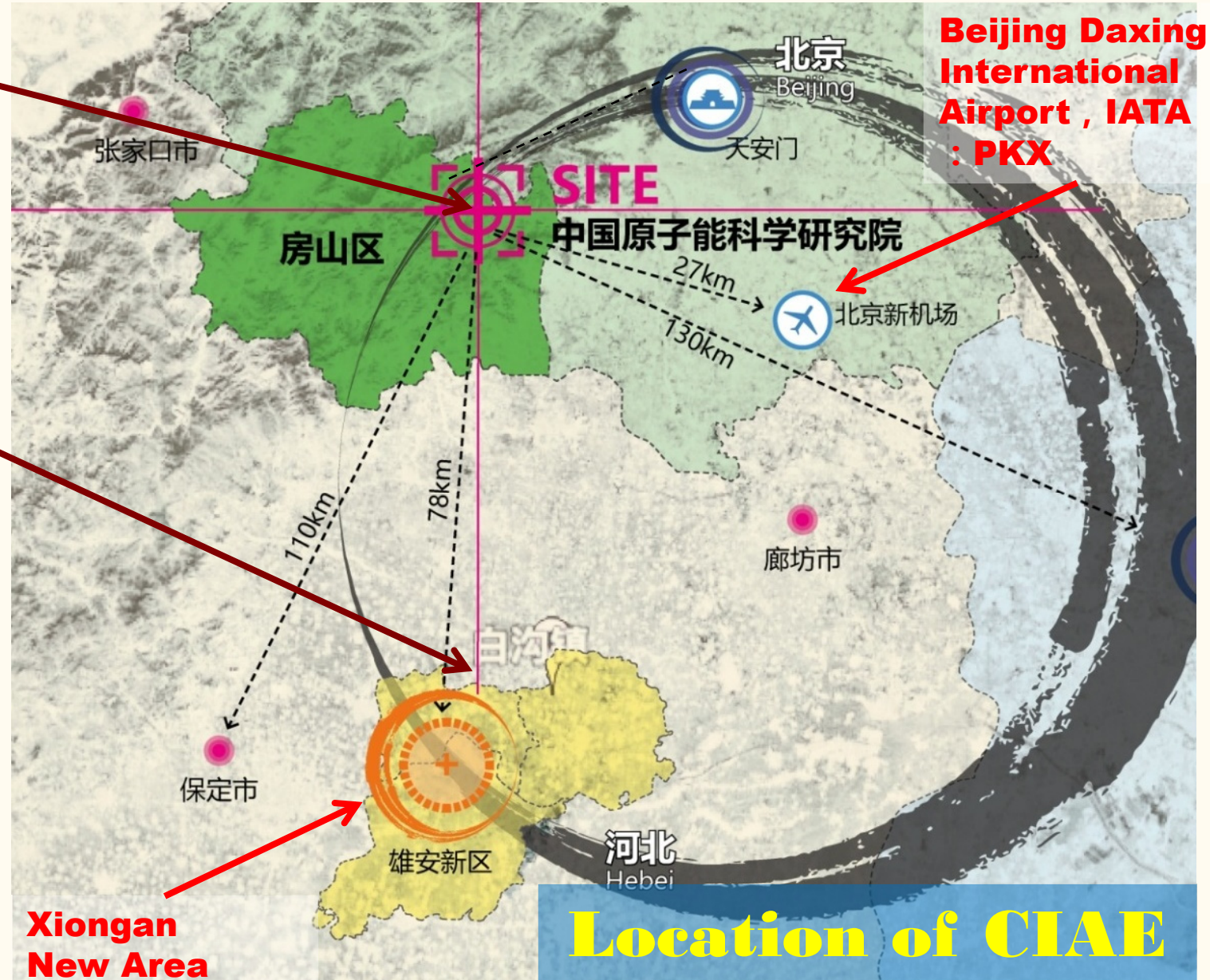

From Cyclotron to CW FFAG, 60 Years Isochronous Road toward High Energy and High Power at CIAE

CIAE was found in 1950, got its first beam from the cyclotron in 1958. There are currently 3,000 employees, plus 2,000 PhD students, postdoctors, visiting researchers and contractual personnel.

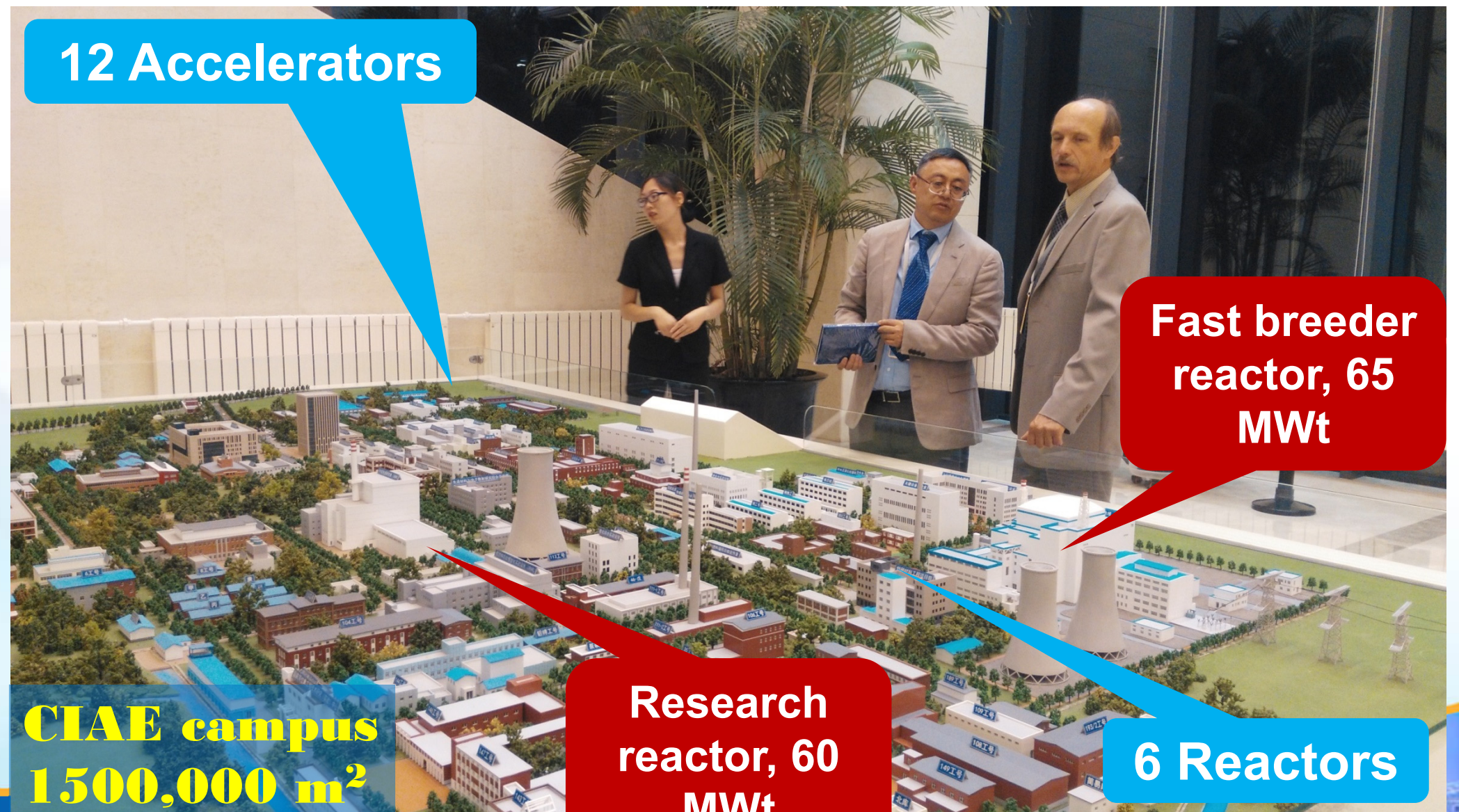

12 Accelerators

Fast breeder reactor, 65 MWt

Research reactor, 60 MWt

6 Reactors

**CIAE campus
1500,000 m²**

30 MeV Cyclotron for Isotopes Production

10 MeV, 14 MeV Cyclotrons for PET & BNCT

230 MeV SC Cyclotron for PT

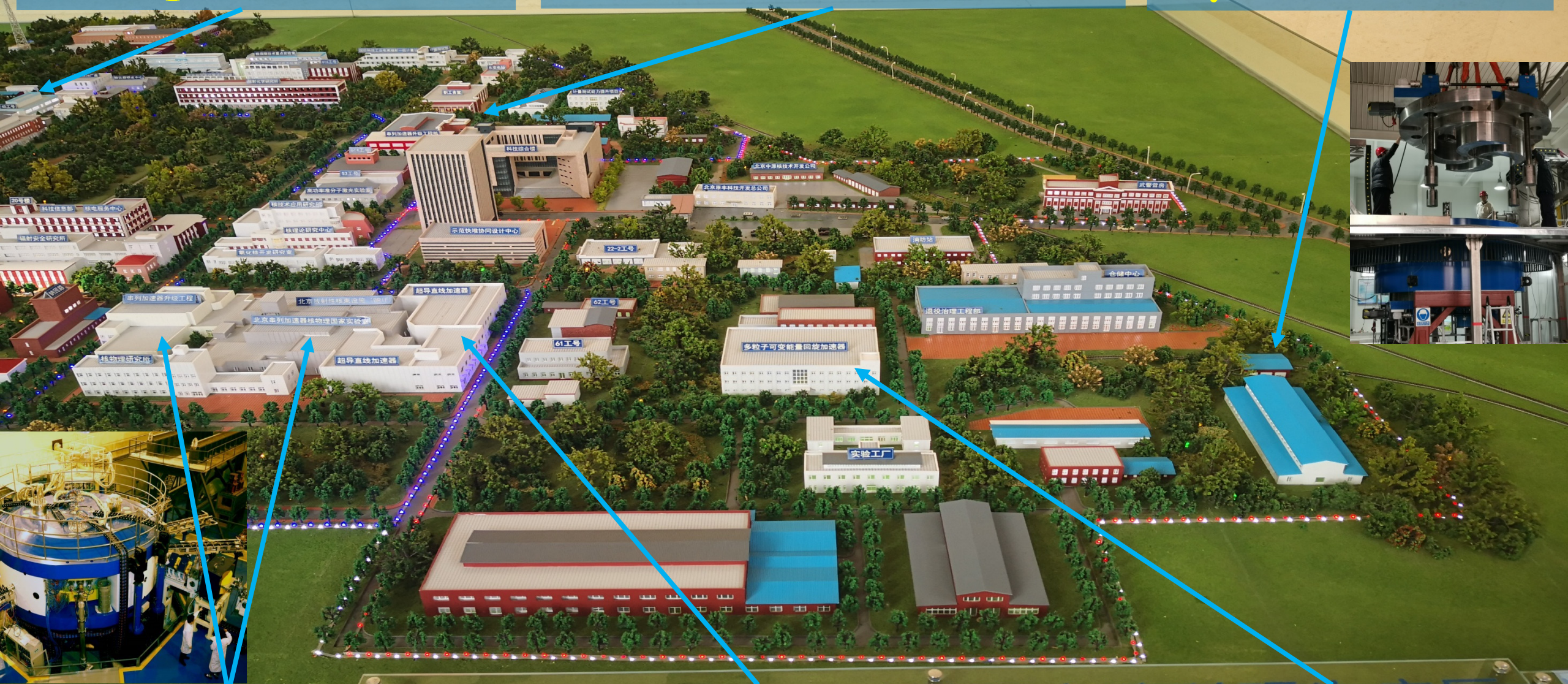

100 MeV Cyclotron & BRIEF

17 MeV/u SC LINAC

72 MeV PSI Injector I

中国科学院高能物理研究所

1. 52 kW CW Proton Beam Production by CYCIAE-100

- a) Introduction about BRIF & First Proton Beam from CYCIAE-100
- b) 52 kW CW Proton Beam Production
- c) Dual Beam Extraction simultaneously for Multi-applications

2. General Design of High Power, High Energy Circular Accelerator (2GeV, 6MW)

- 1. General Consideration and Beam Dynamics
- 2. R&D for Key components (HT SC Magnet, HP RF System)

3. Other Cyclotron Activities for Medical Applications & more (If I still have time)



BRIF

**Beijing
 Radioactive
 Ion-beam
 Facility**
**Upgrade
 project for
 National
 Tandem Acce.
 Laboratory**

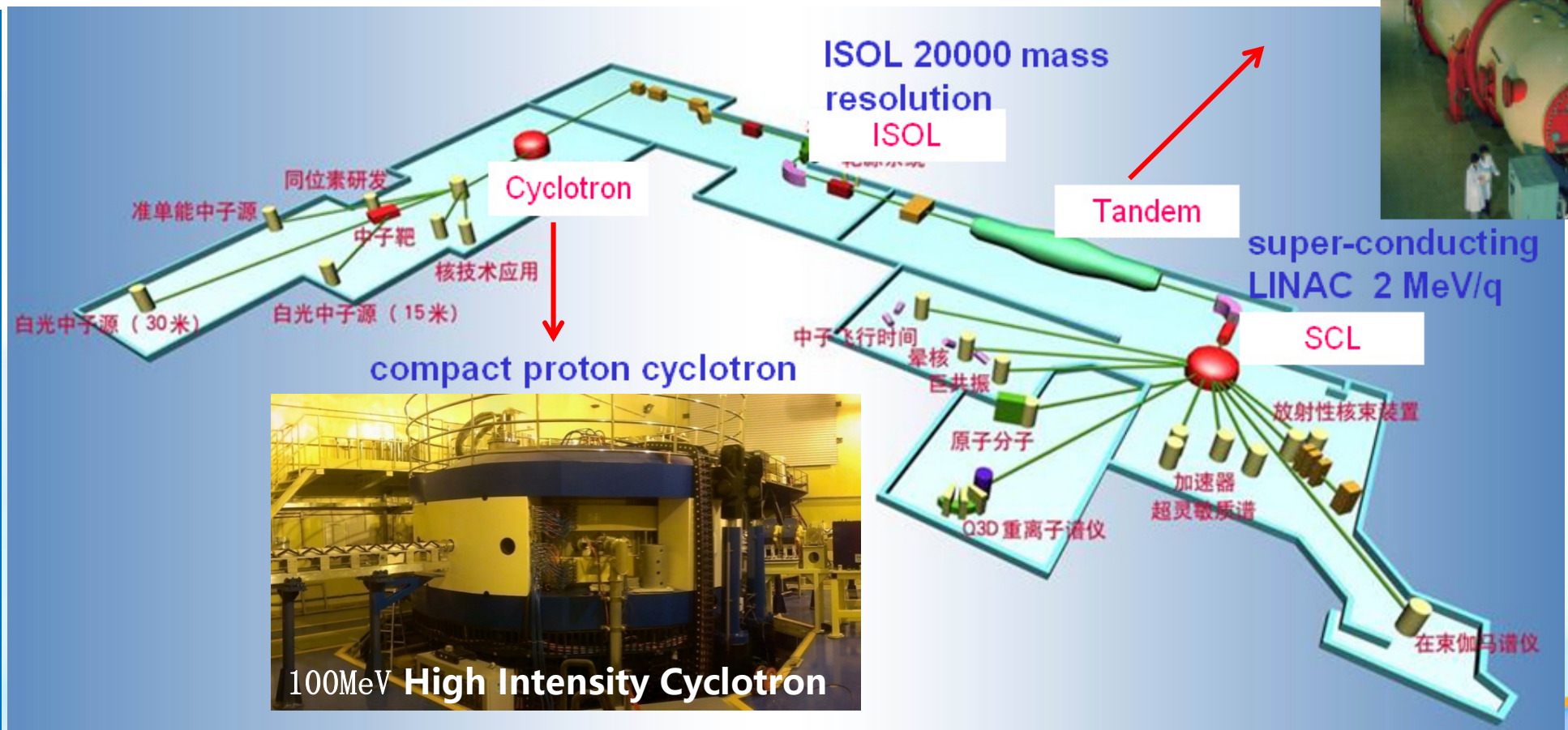

Completed in 2014



- **CW mode, high current**
- **energy variable;**
- **Dual beam extracted simultaneously;**
- **Low beam losses**

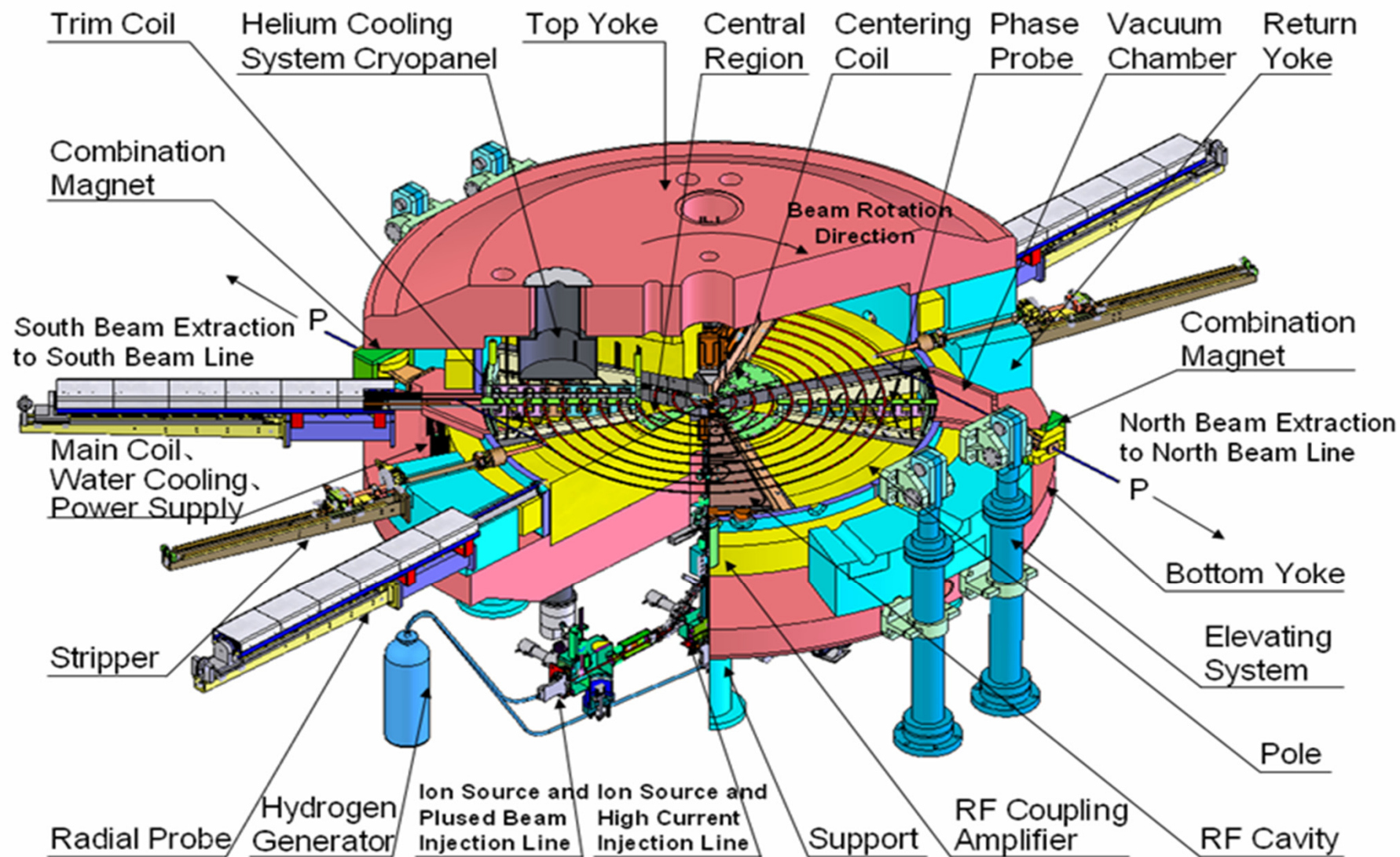

First stage: 70MeV~100MeV, 200~500 μ A: 20kW~50kW
Second stage: 30 MeV ~ 100 MeV, 1mA, 100kW.

Six highlights during 100MeV Cyclotron Construction

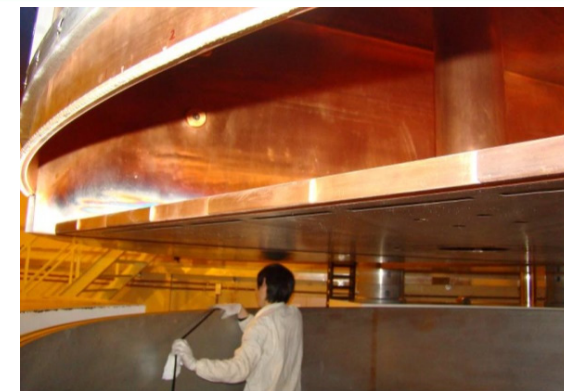
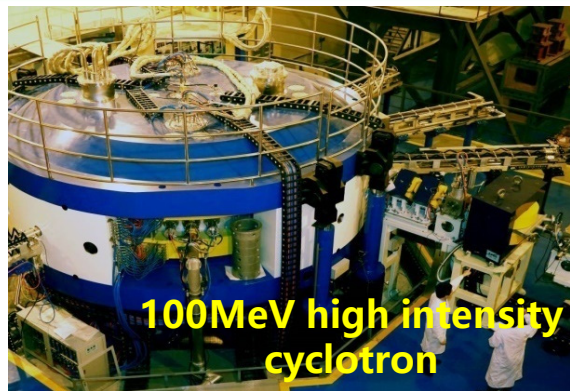
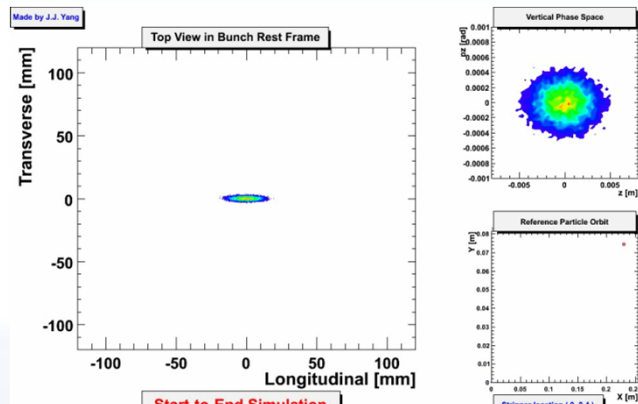

Core algorithm: Cyclotron beam dynamics research & code development.

AVF cyclotron with straight sector and higher energy than 70 MeV first time.

First implementation with two-stem cavity and highest Q value for AVF cyclotron.

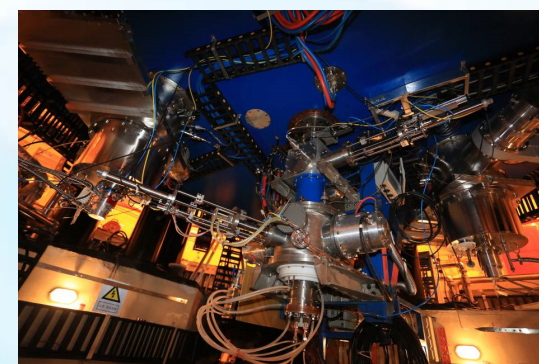
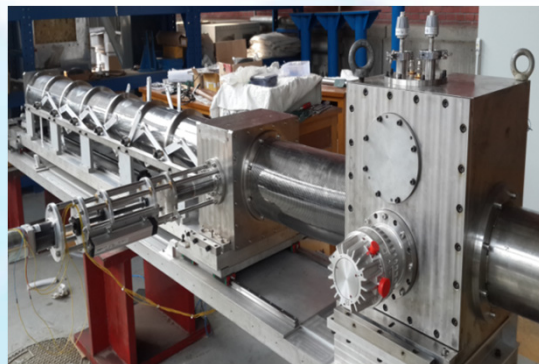

Beam in two directions simulta. by 4D adjust & orbit matching.

Highest beam achieved by ion source and central region matching tech.

The first time to get **full mapping data in vacuum** for big cyclotr

Seven
proton
beam
lines
were
built
for
various
applicat
ions

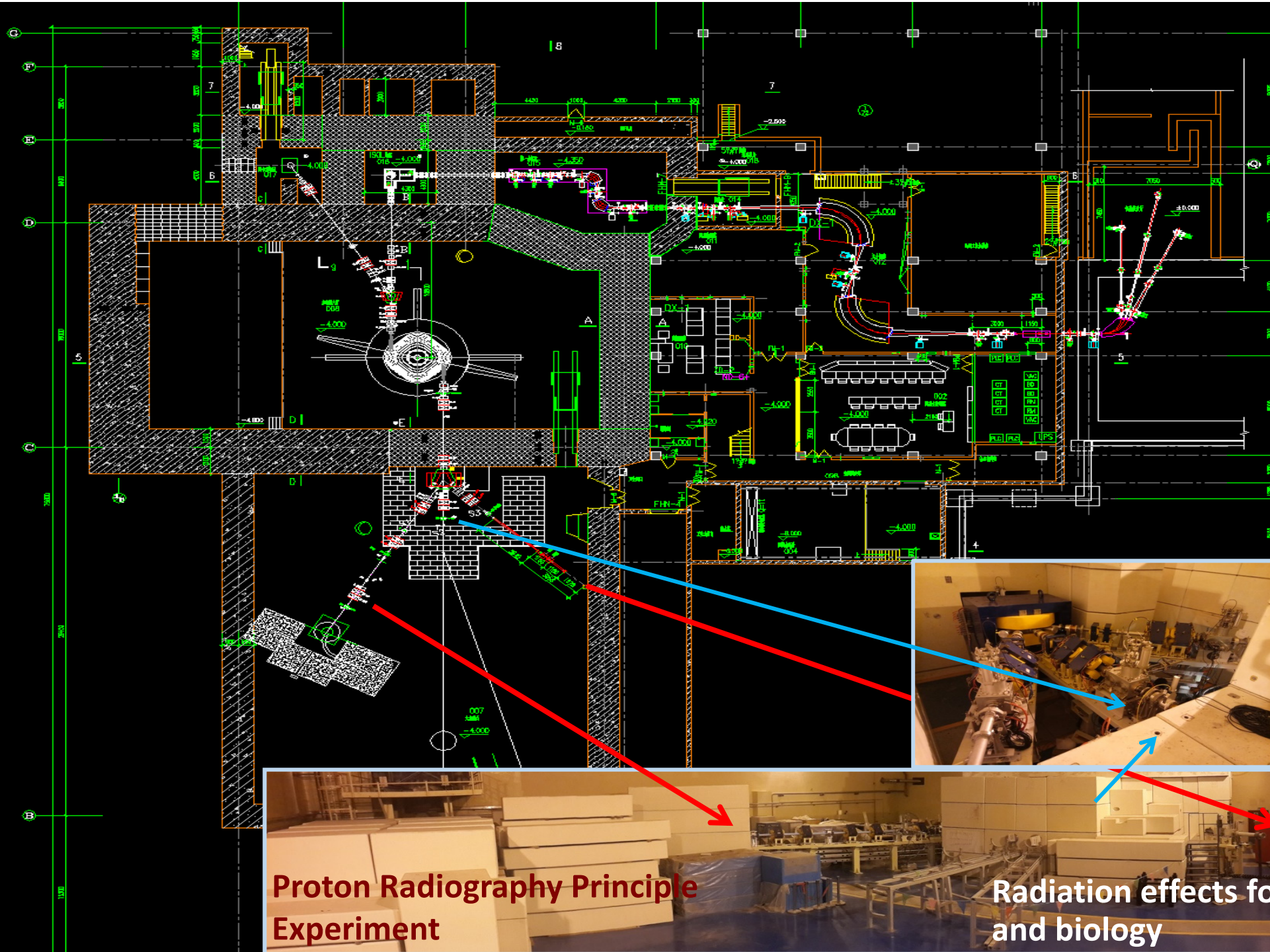

Wide
Spectra
Neutron
Source



Proton Radiography Principle
Experiment

Radiation effects for electronics
and biology



Beam Dump & Isotope Production

Seven proton beam lines were built for various applications

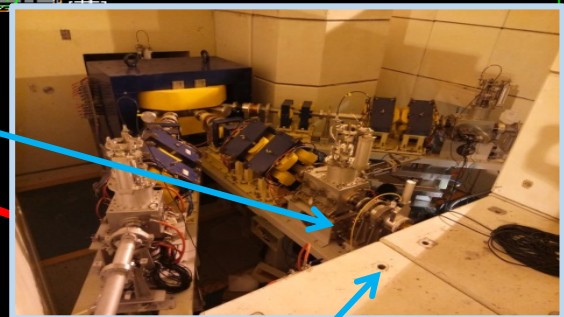
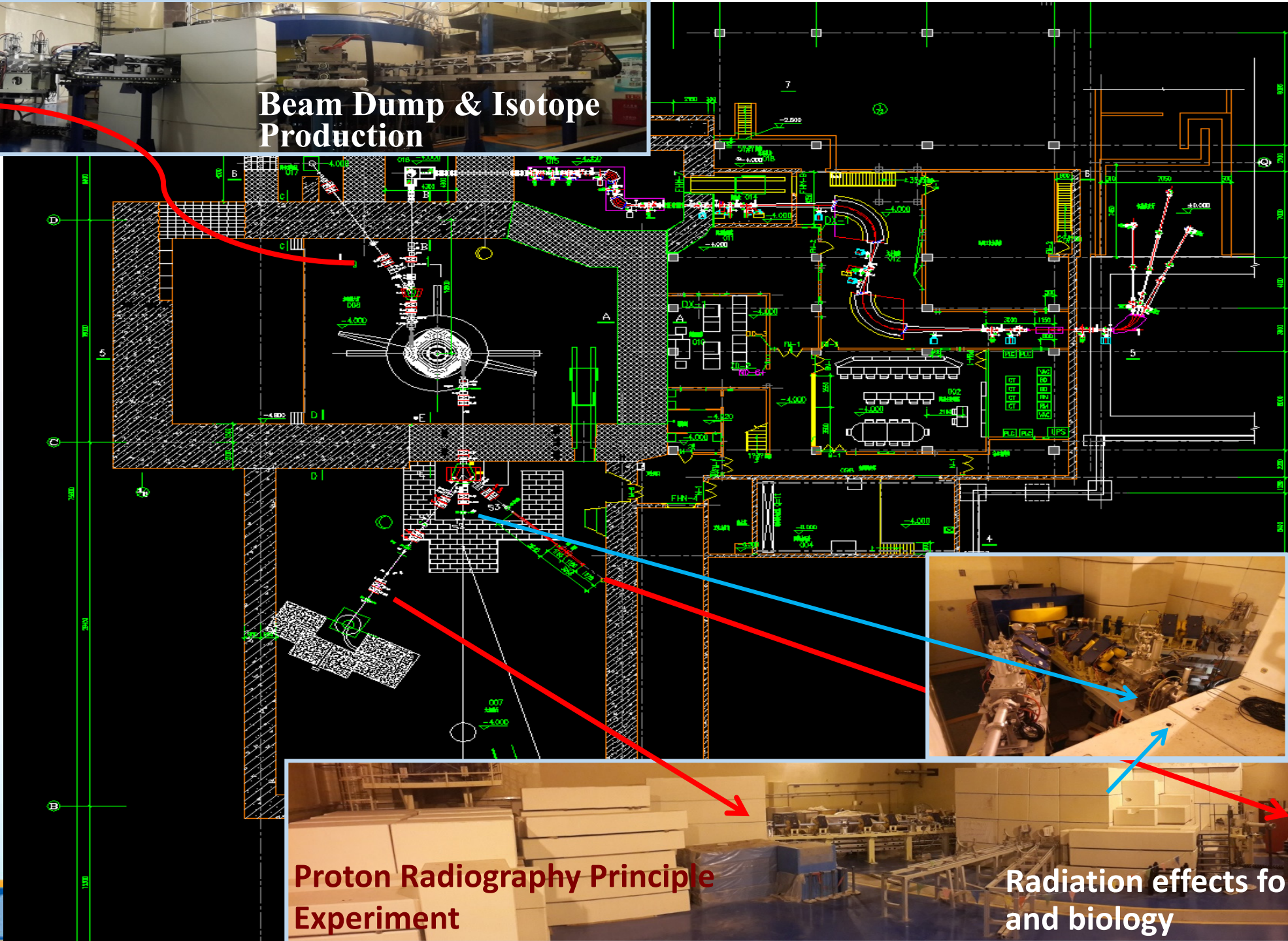

Wide Spectra Neutron Source



Proton Radiography Principle Experiment

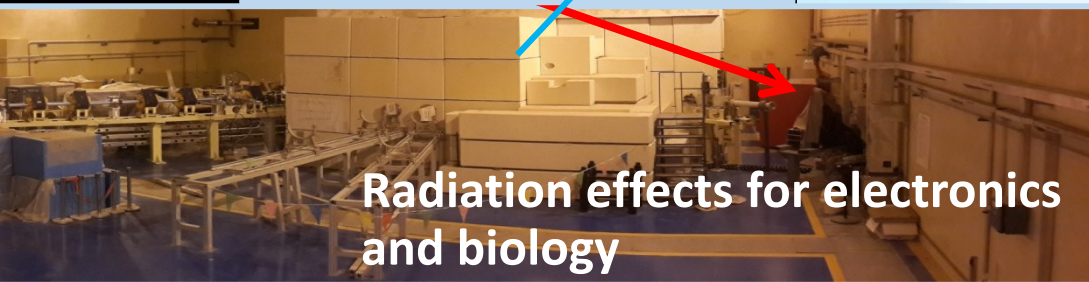

Radiation effects for electronics and biology



Beam Dump & Isotope Production



Beam Line for ISOL System

Seven proton beam lines were built for various applications

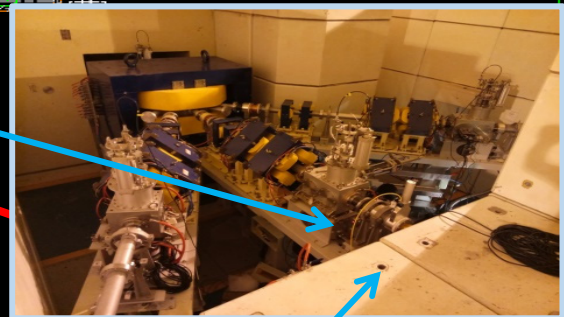
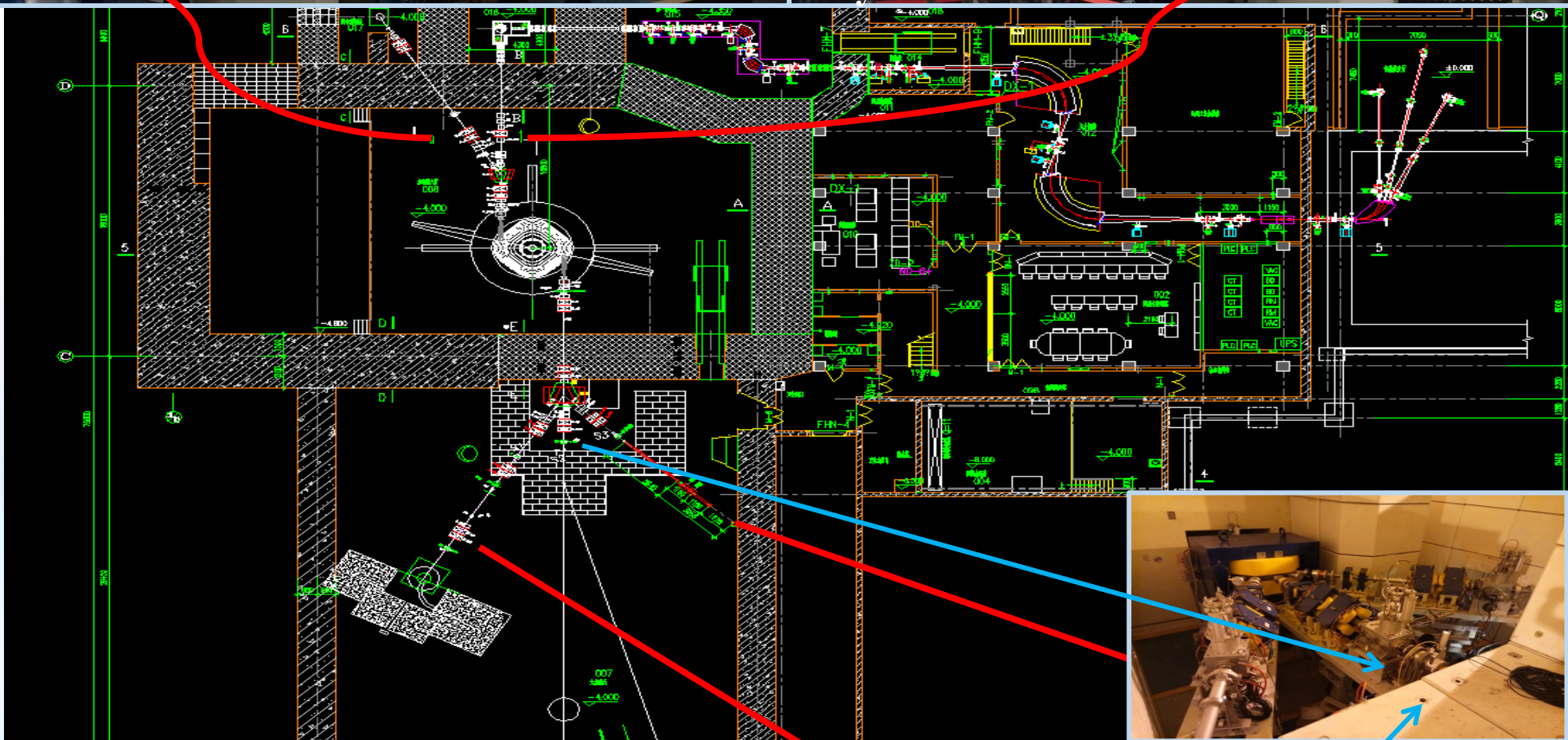

Wide Spectra Neutron Source



Proton Radiography Principle Experiment



Radiation effects for electronics and biology





Beam Dump & Isotope Production



Beam Line for ISOL System

Seven proton beam lines were built for various applications

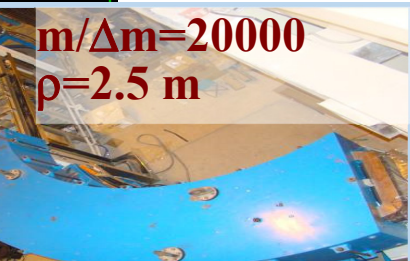
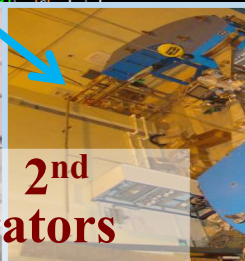
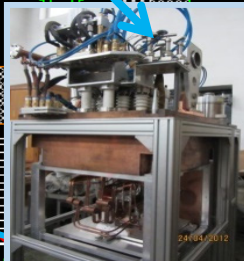
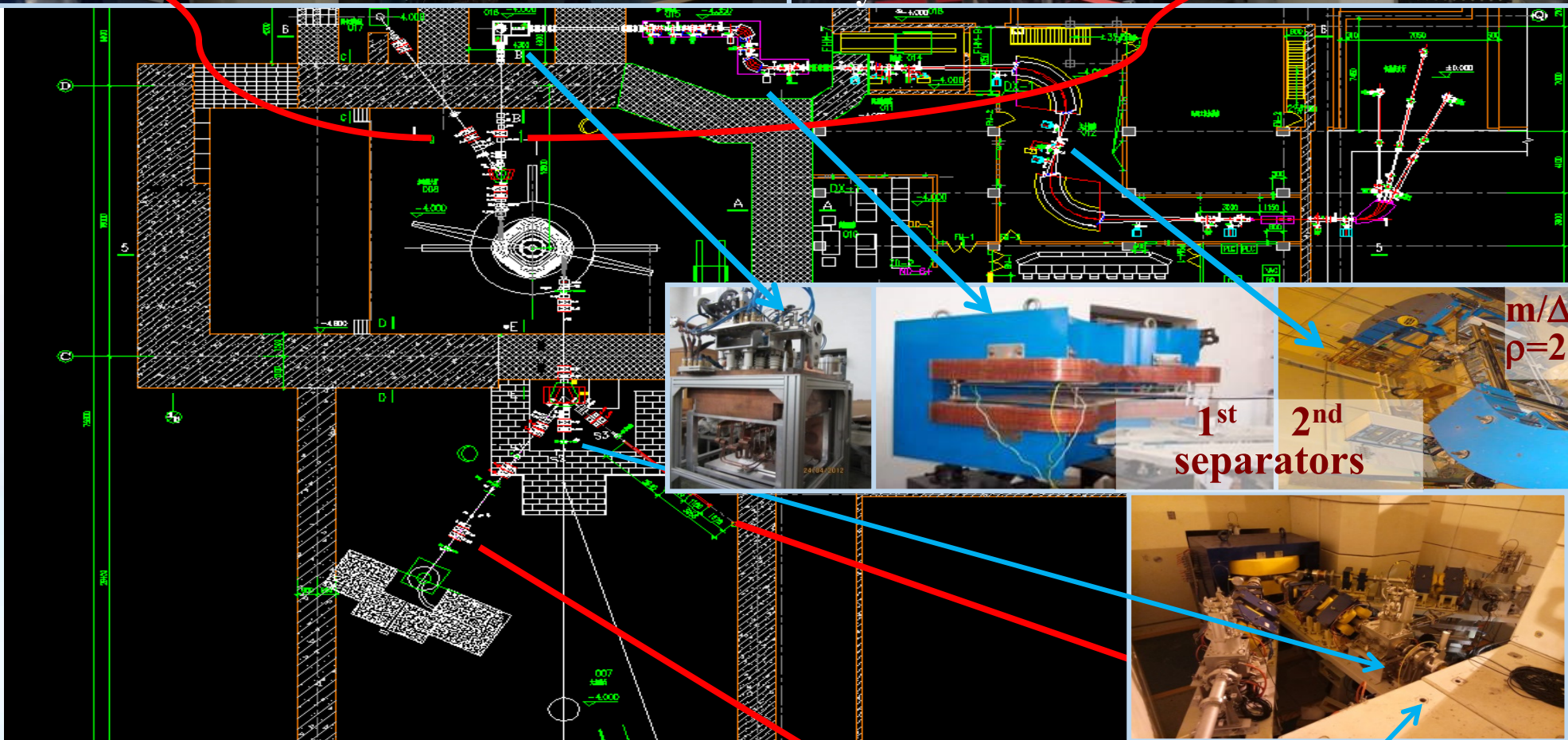

**1st
2nd
separators**

$m/\Delta m = 20000$
 $\rho = 2.5 \text{ m}$

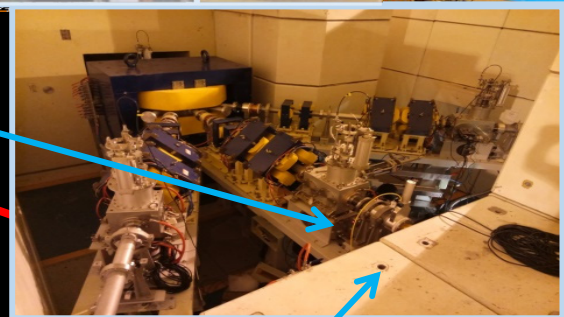

Wide Spectra Neutron Source



Proton Radiography Principle Experiment



Radiation effects for electronics and biology



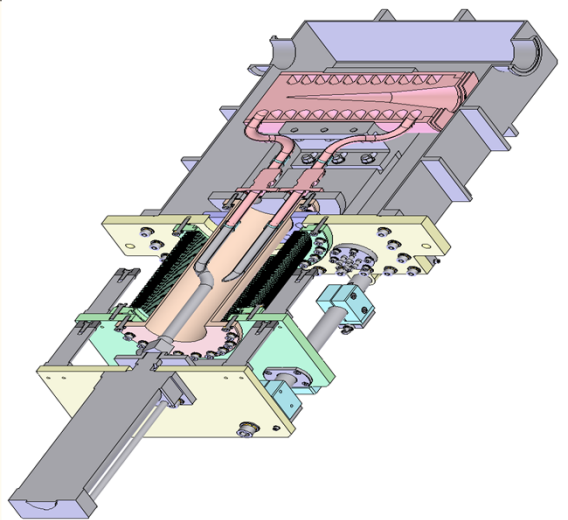

Beam Intensity can be fine adjustable from 10pA, nA to a few μA , with about 1% stability for one week continuous operation.

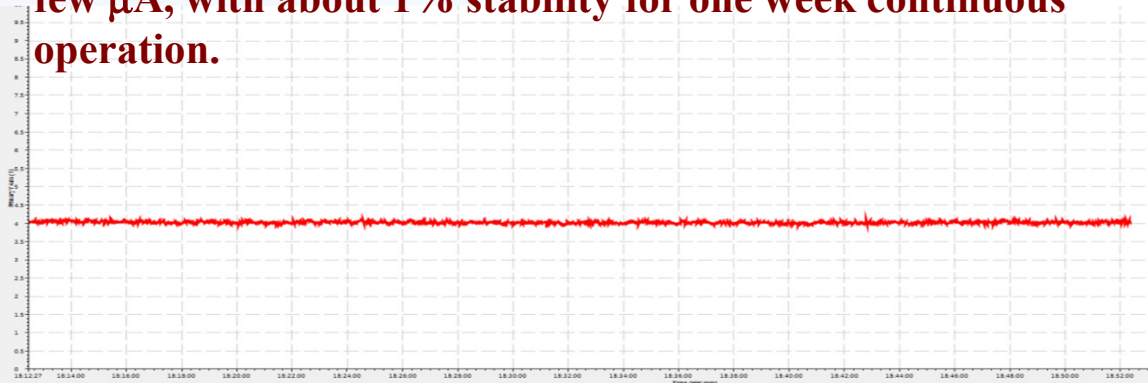

引出剥离靶束流:

4.03 μA

Proton Irradiation

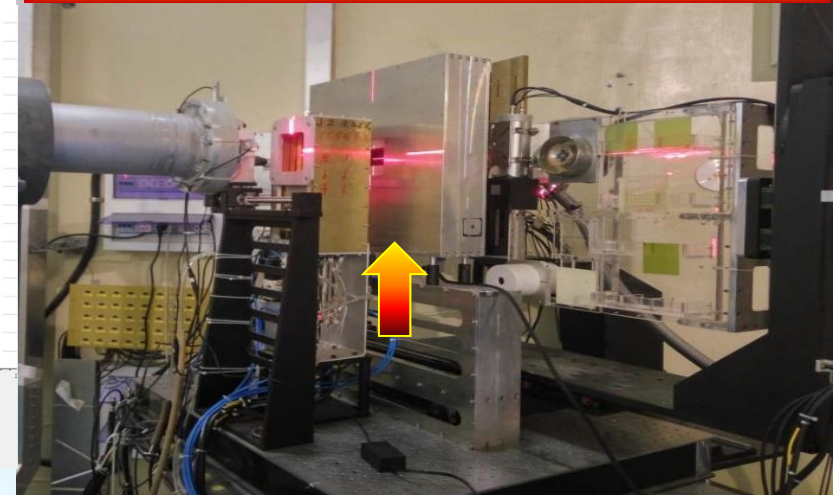

Proton Radiography Principle Experiment



1. Highest beam power of 52kW ...
...;
2. Wide range of beam intensity 2pA~520 μA.

Open for Users every year

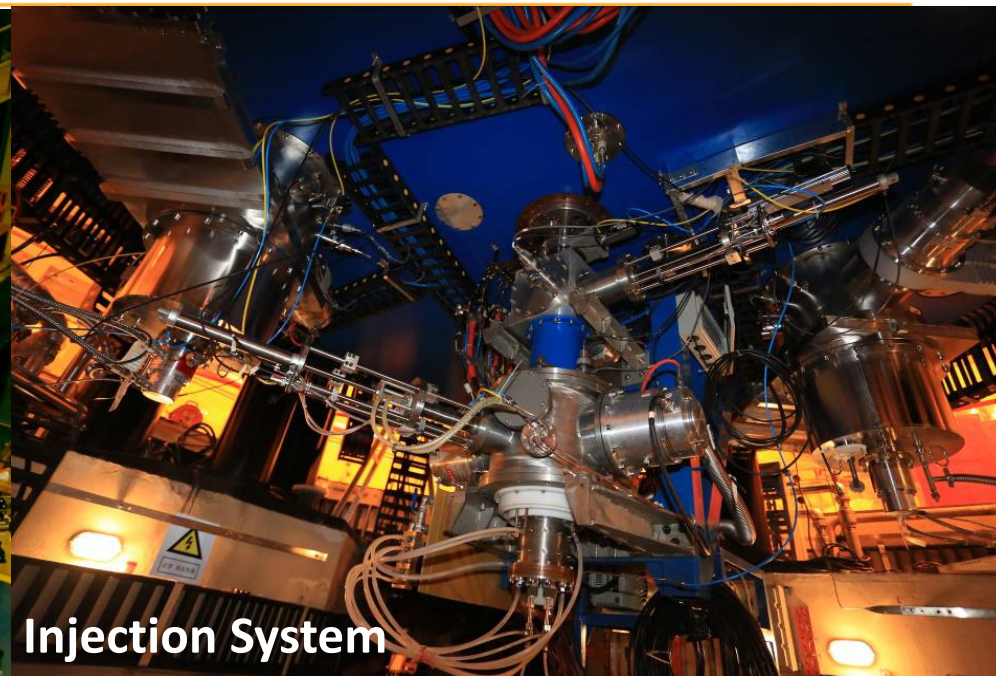
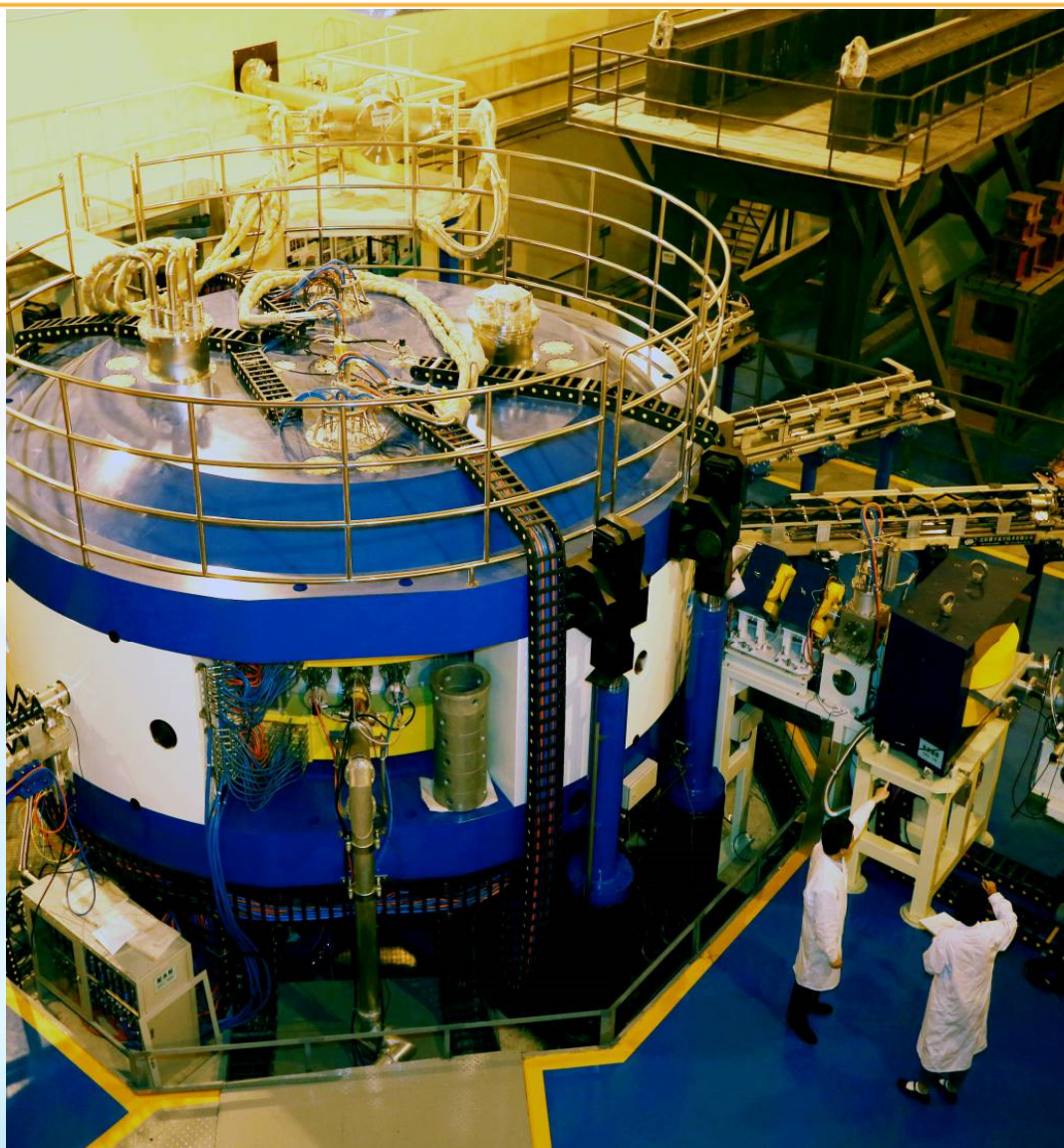

Injection System



Control Room

100MeV High Intensity Cyclotron

12 hours running test with extracted beam current > 23 μ A,
on July 25, 2014

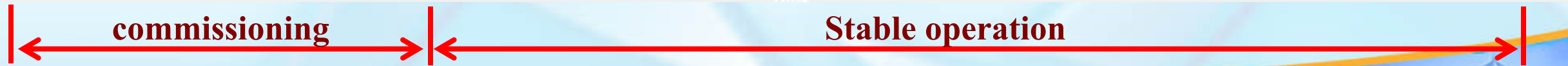
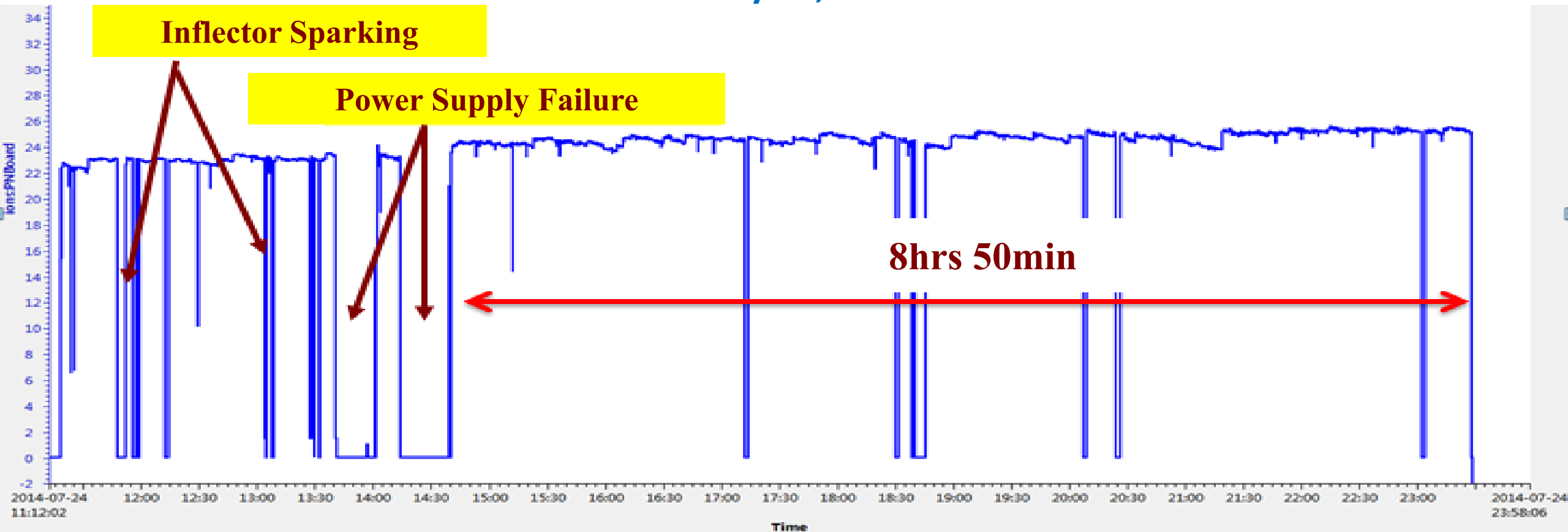

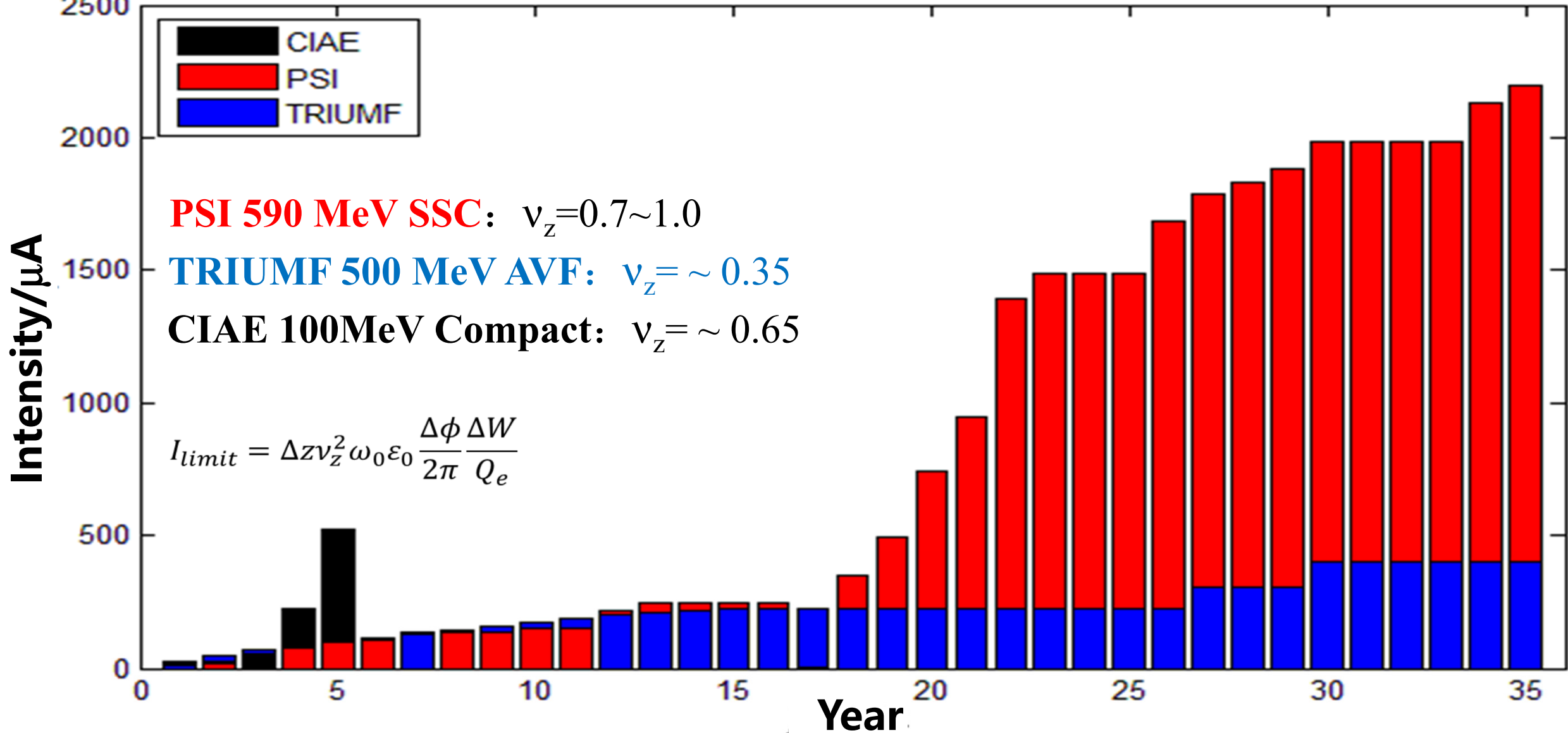

PSI 590MeV, 2mA, TRIUMF 500MeV, 400μA, CIAE 100MeV 520μA

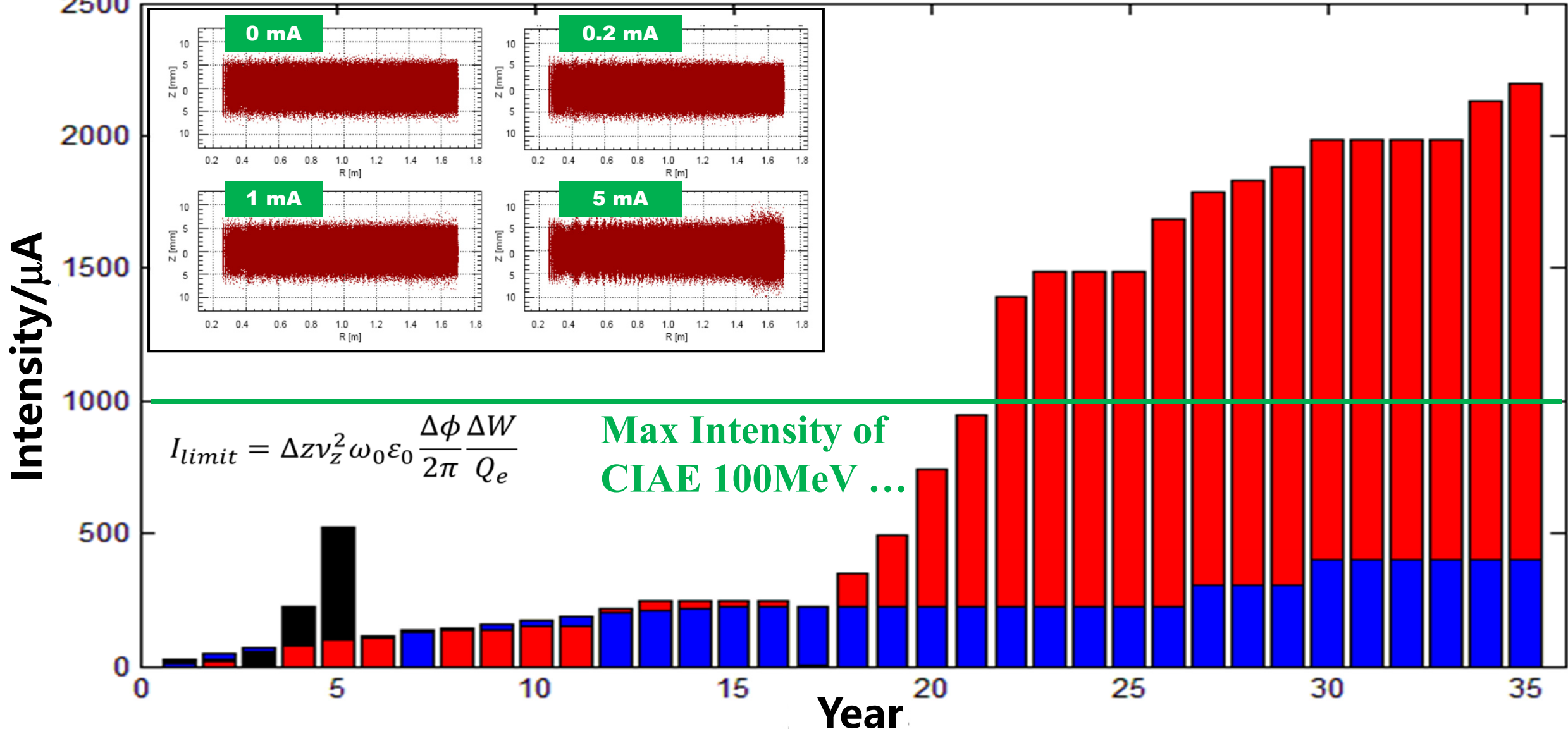

PSI 590MeV, 2mA, TRIUMF 500MeV, 400 μA , CIAE 100MeV 520 μA

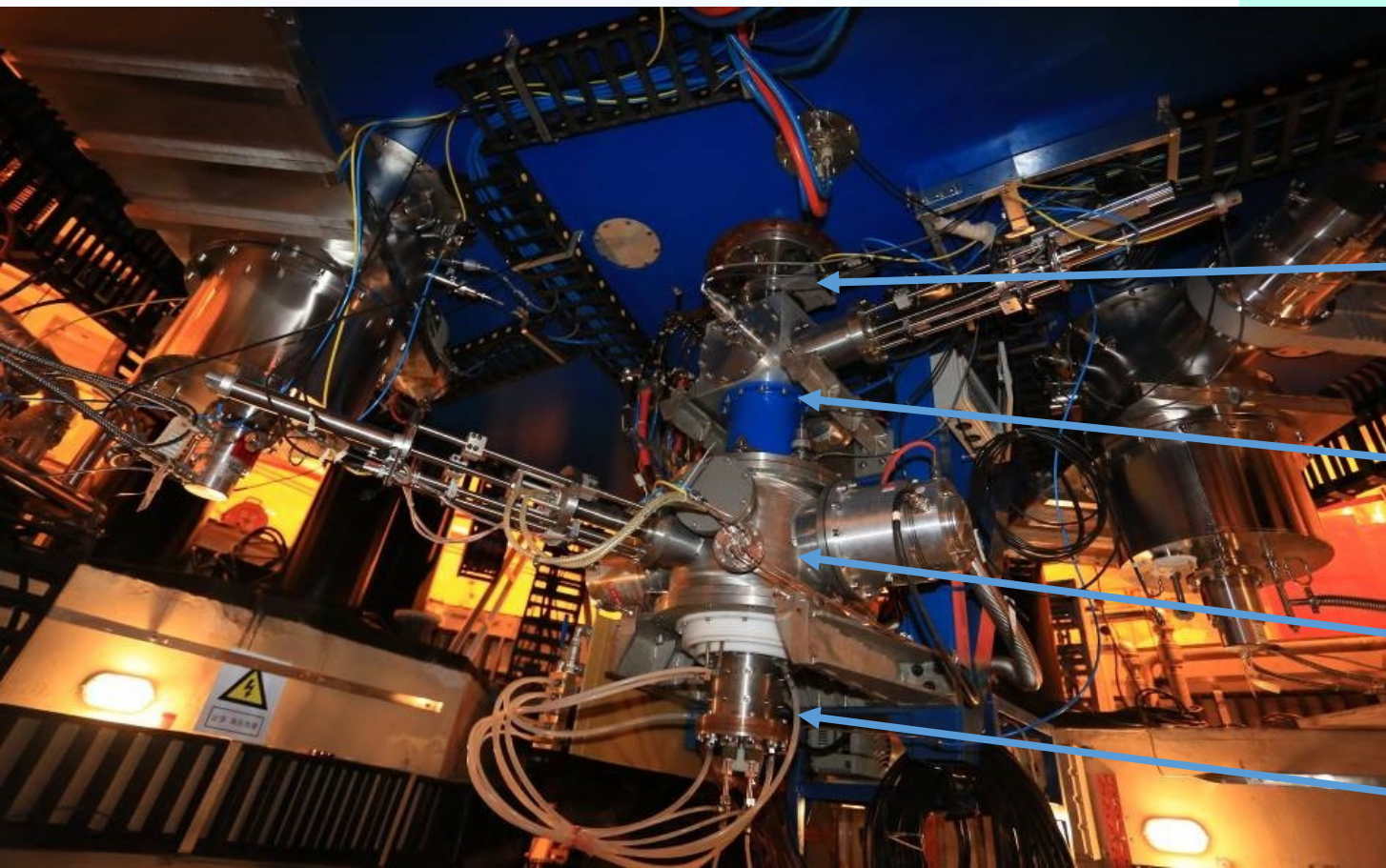
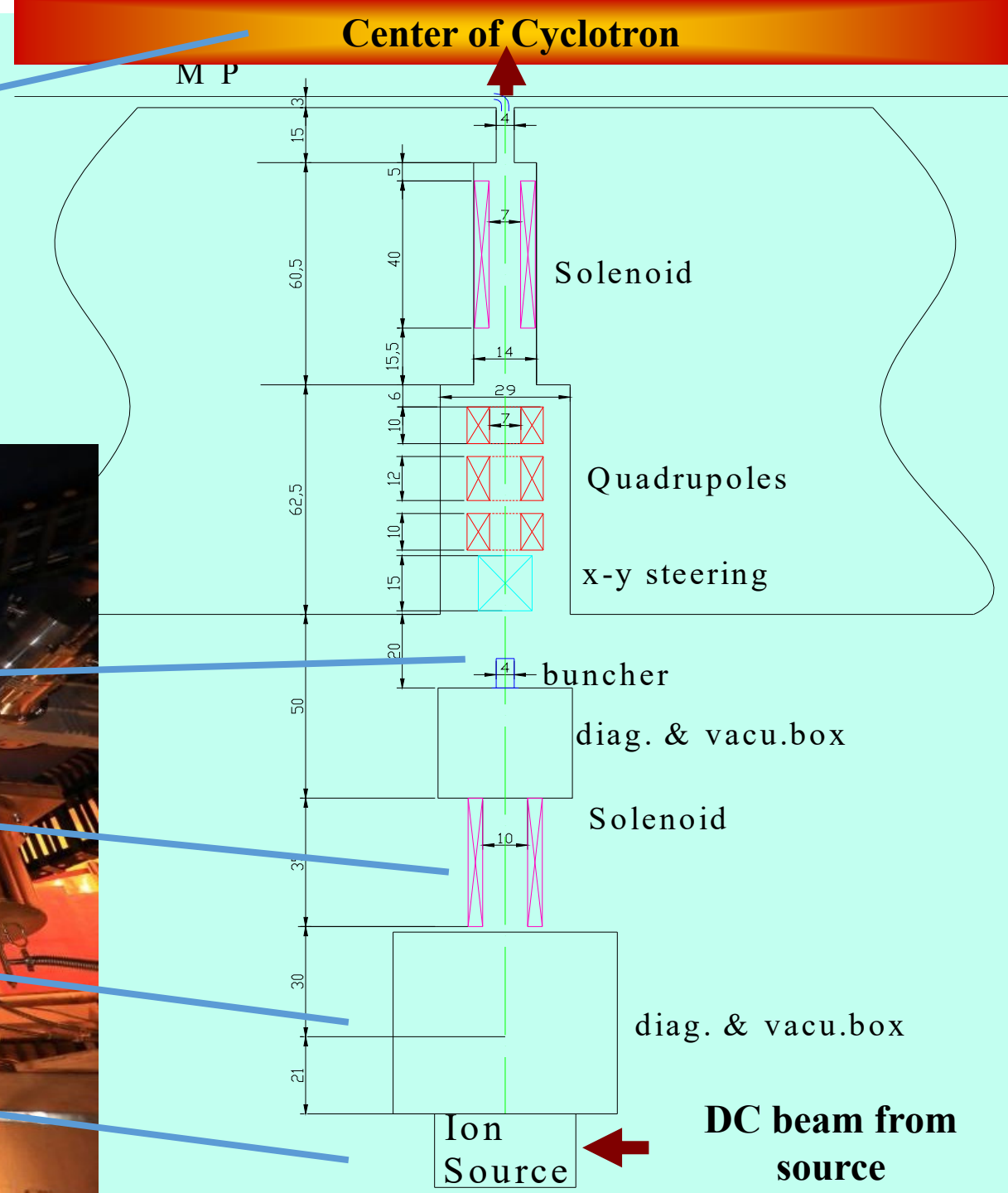
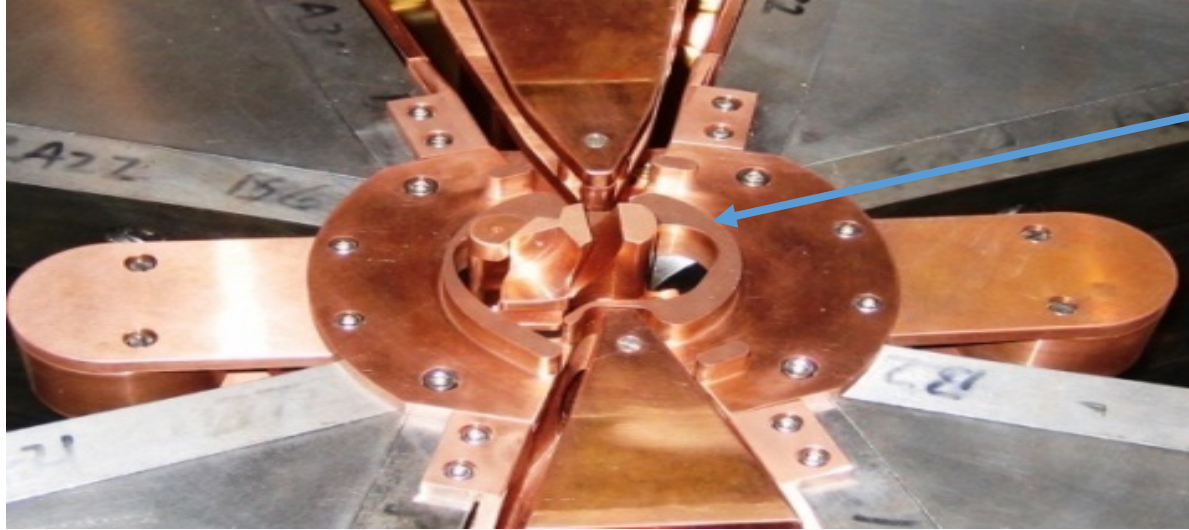

52 kW CW Proton Beam Production

- The multi-cusp ion source on the test stand:
- 18mA, 30 keV
- → 10mA, 40 keV

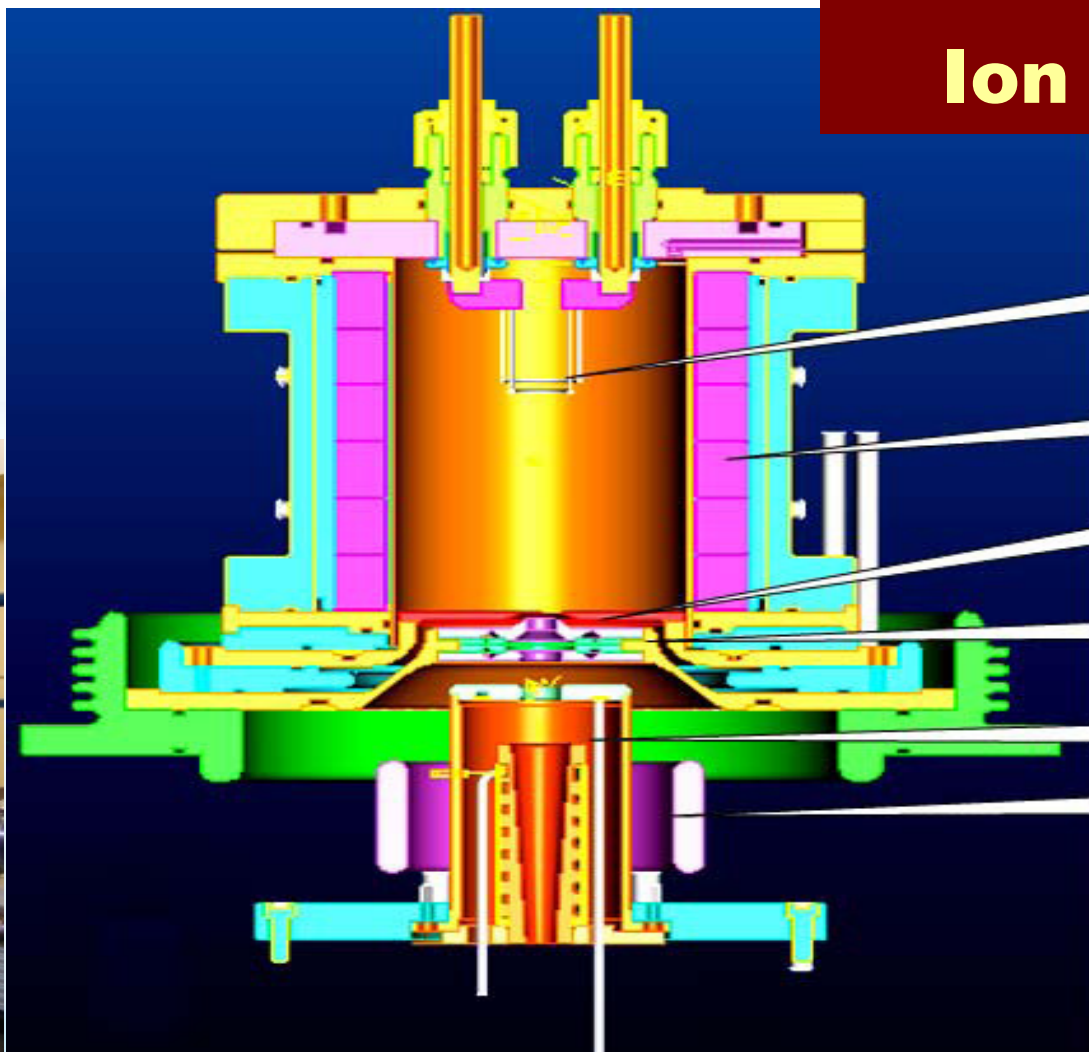
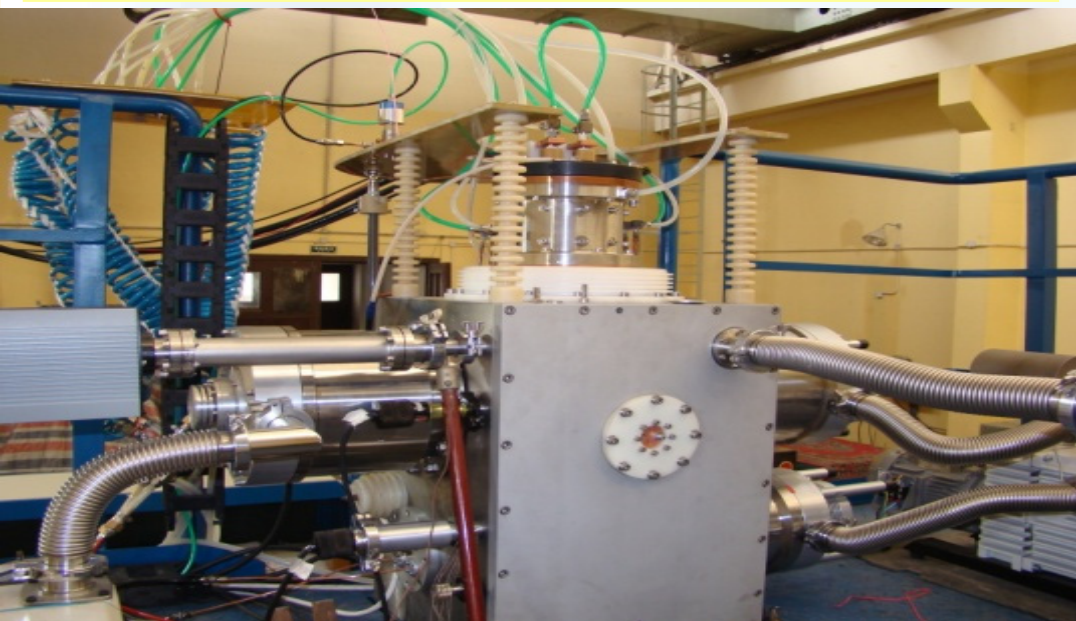

**H-
Ion source**

filament

**Improvement
of the
extractor &
cusp**

**New ground
electrode &
XY magnet**



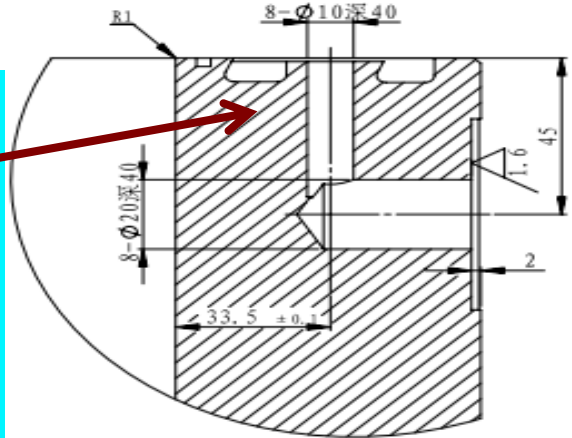
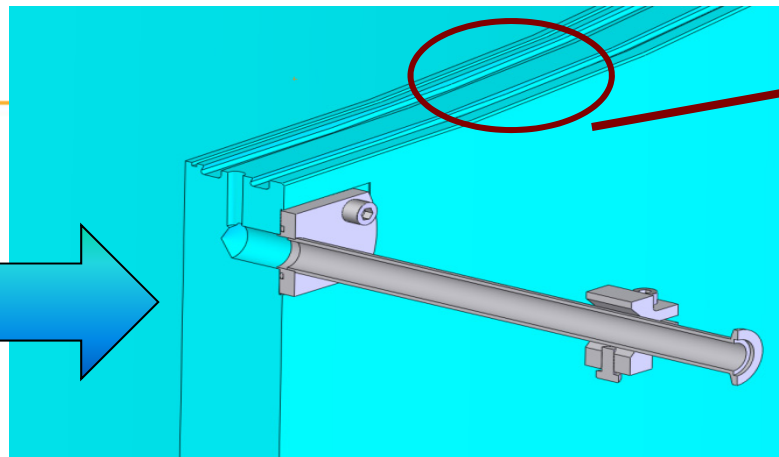
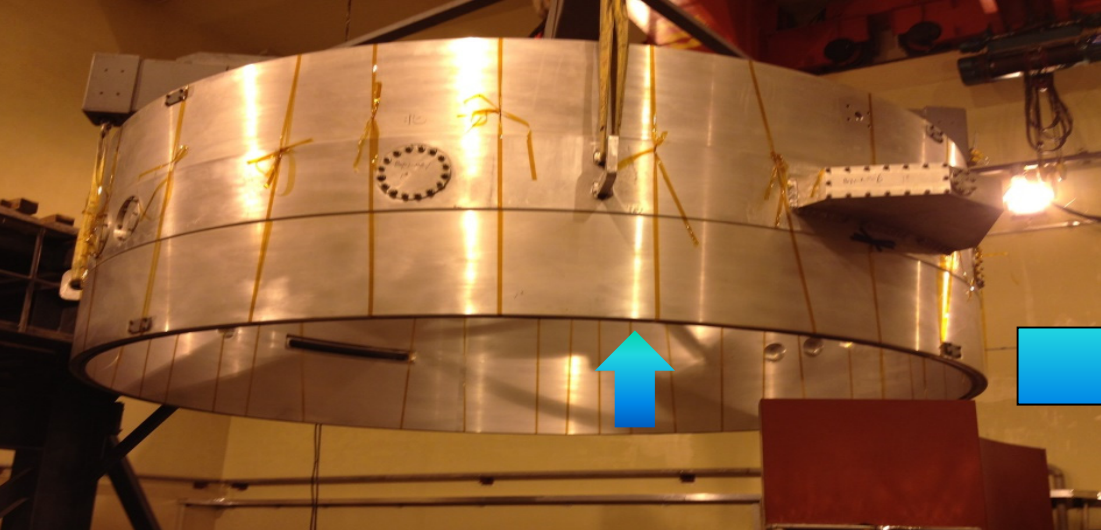

Vacuum Dissociation, H- Beam Losses

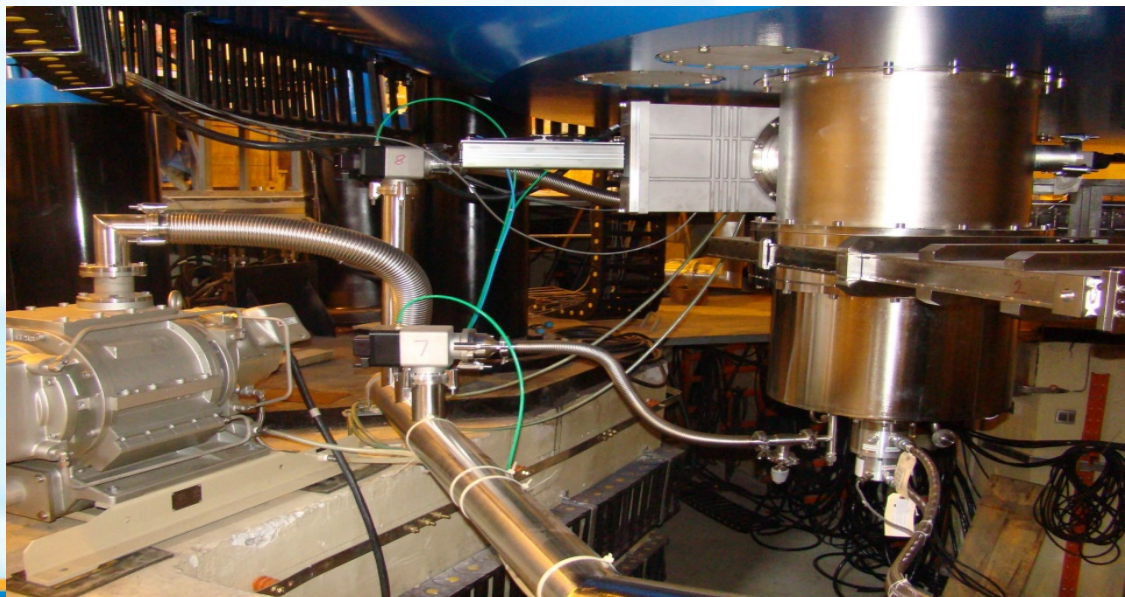
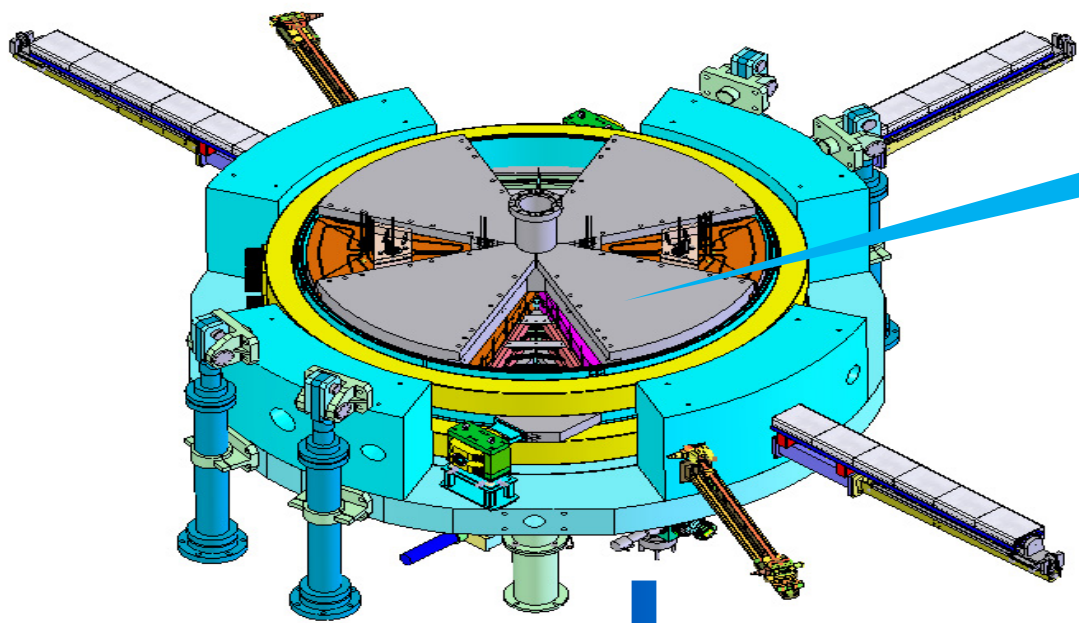

Double layer pumping system for main vacuum improvement

52 kW CW Proton Beam Production

- ❑ Non-intercepting 2-gap buncher
- ❑ Between the first solenoid and the triplet, ~1.1m away from the inflector.
- ❑ Gap=5 mm and $D=0.5\beta\gamma$ instead of $1.5\beta\gamma$ at TRIUMF

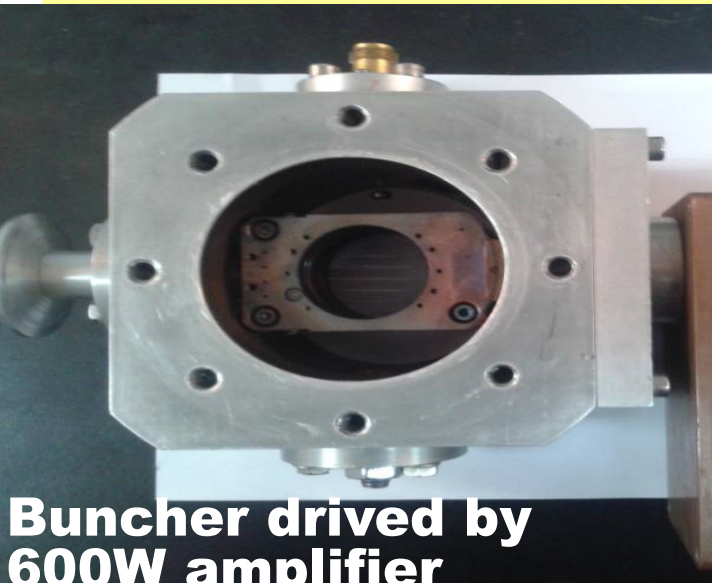
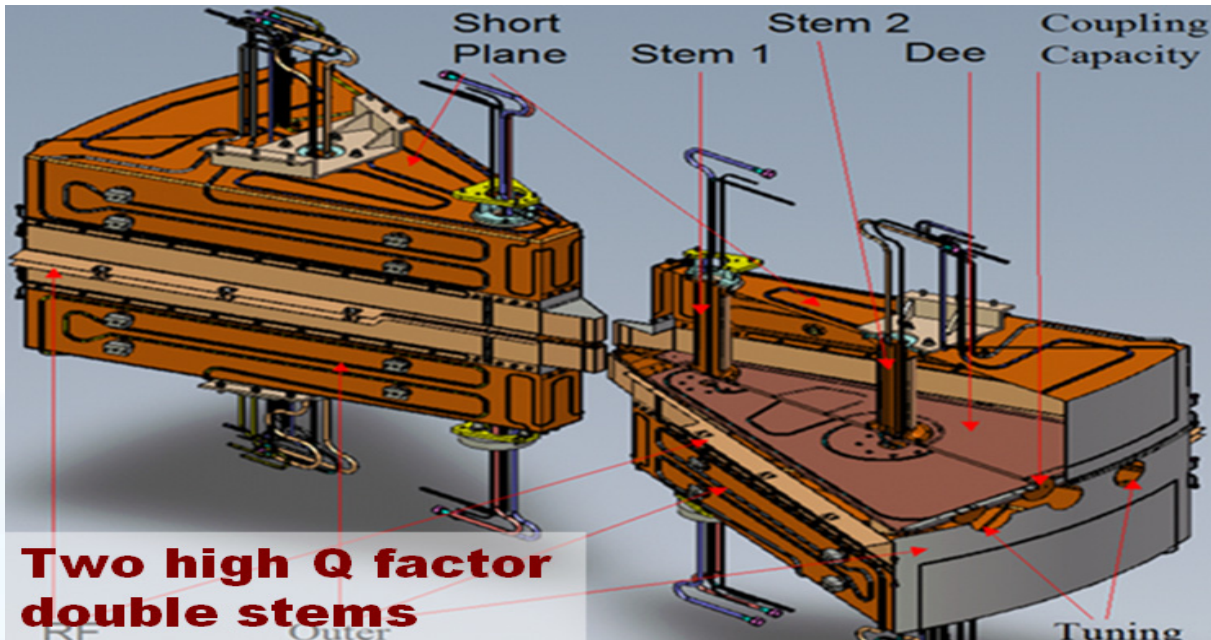

Buncher

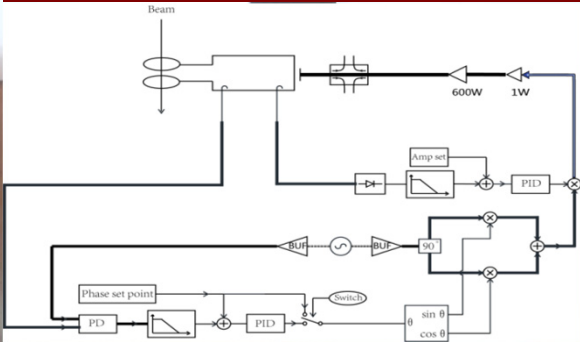

Bunching Gain 1.6 (60%) @ 520 μA beam extracted

RF Cavity

幅度闭环	加速电压(VDee)	61.5392	kV
相位闭环	加速相位(Phase)	-33.6	Deg.
调谐闭环	系统驻波(VSWR)	1.35	
阳极	阳压	11.3	kV
	阳流	5.4	A
帘栅	栅压	1.03	kV
	栅流	0.019	A
偏压	偏压	352.4	v
	偏流	0.001	A
灯丝	电压	14.3	v
	电流	199.1	A

西南调制器	功率	33.4	kW
东北调制器	功率	33.9	kW

幅度闭环	加速电压(VDee)	61.6809	kV
相位闭环	加速相位(Phase)	0.8	Deg.
调谐闭环	系统驻波(VSWR)	1.45	
阳极	阳压	11.4	kV
	阳流	5.1	A
帘栅	栅压	1.17	kV
	栅流	0.105	A
偏压	偏压	399.7	v
	偏流	0.083	A
灯丝	电压	14.3	v
	电流	194.3	A

Buncher driven by 600W amplifier

52 kW CW Proton Beam Production

Nov. 23, 2018, More than **200 μ A** Proton Beam and Its **Efficiency** were measured

Beam Intensity			Extracted Beam Energy (MeV)	Efficiency (Incl. acceleration, Extraction and Transportation)
Ion Source (mA)	Internal Target (μ A)	Beam Dump (μ A)		
2.44	215	213	100	99.07%



52 kW CW Proton Beam Production

Beam evolution



Nov. 29, 2018, External Experts Tested for National Acceptance and **520 μ A** Proton Beam Extracted



52 kW CW Proton Beam Production

Beam evolution

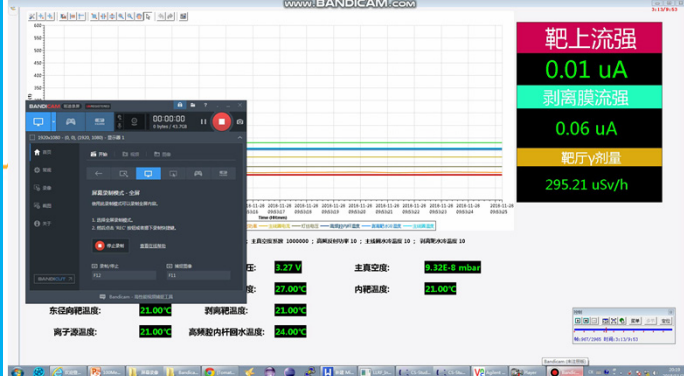

Nov. 29, 2018, External Experts Tested for National Acceptance and **520 μ A** Proton Beam Extracted



BRIF

**Proton,
 Neutron,
 Radioactive
 Ion beam,
 open for
 users**
**You are
 welcome**

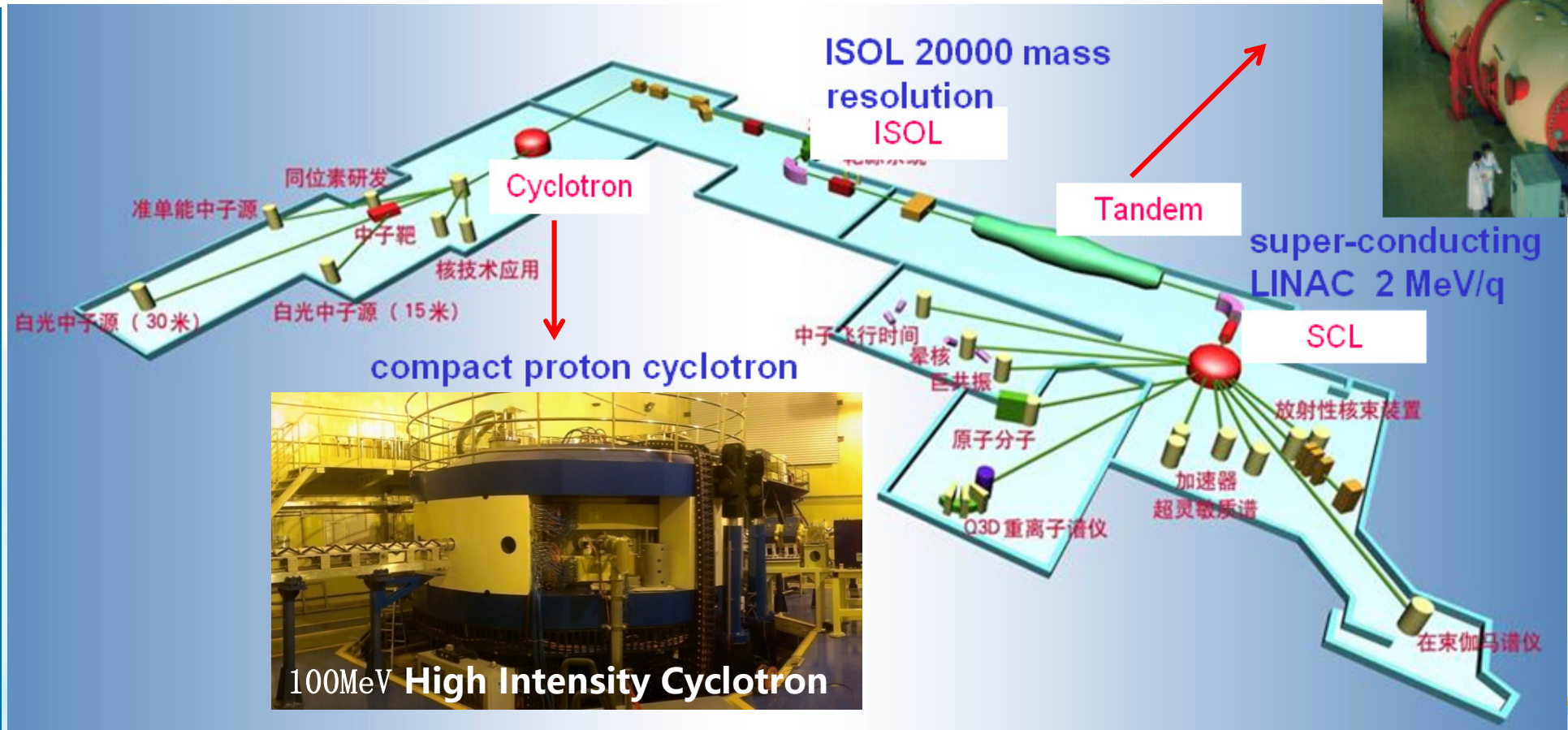

100MeV High Intensity Cyclotron

Completed in 2014



1. 52 kW CW Proton Beam Production by CYCIAE-100

- a) Introduction about BRIF & First Proton Beam from CYCIAE-100
- b) 52 kW CW Proton Beam Production
- c) Dual Beam Extraction simultaneously for Multi-applications

2. General Design of High Power, High Energy Circular Accelerator (2GeV, 6MW)

1. General Consideration and Beam Dynamics
2. R&D for Key components (HT SC Magnet, HP RF System)

3. Other Cyclotron Activities for Medical Applications & more (If I still have time)



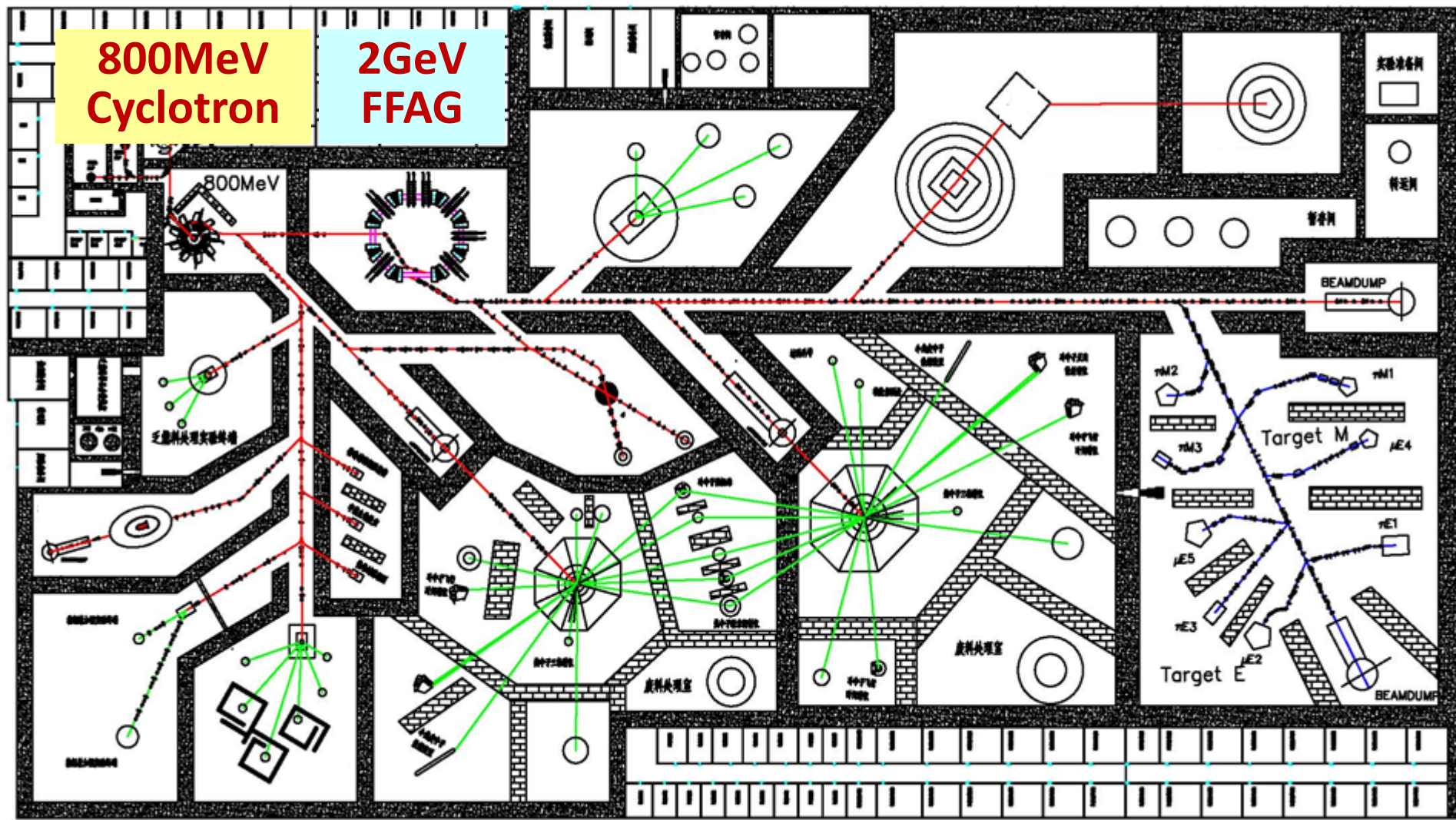

□ Motivations: As everyone knows, there are a lot to list for fundamental physics and nuclear industry applications.

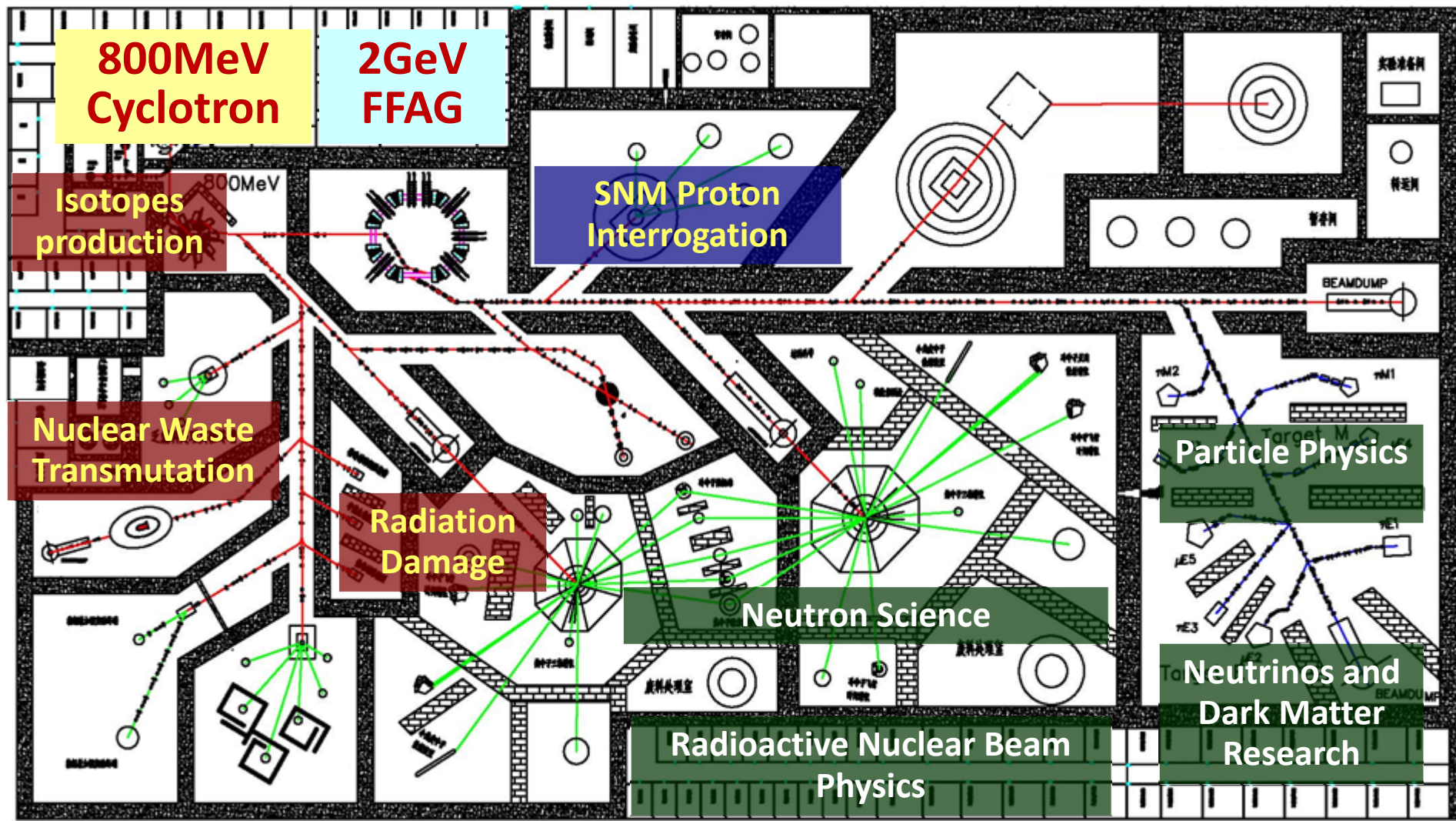

□ Motivations: As everyone knows, there are a lot to list for fundamental physics and nuclear industry applications.

High Power Proton Accelerator:

Cyclotron, LINAC and RC Synchrotron

The average power of the three different types of constructed accelerators currently is from 0.2MW to 1.4MW

Institute	Facility	Energy (MeV)	Power (kW)	Current (uA)	Repetition rate (Hz)	Remark
RAL	ISIS	800	200	250	30	Short pulse
JAERI/KEK	J-PARC	3000	500	167	25	Short pulse
ORNL	SNS	1000	1400	1300	60	Short pulse
LANL	LANSCCE	800	1000	1000	100	Long pulse
PSI	SINQ	590	1400	2400	-	CW
TRIUMF	ISAC	500	200	400	-	CW
Europe	ESS	2000	5000	2500	14	Long pulse
CIAE	CYCIAE-2000	2000	6000	3000	-	CW

RC Synchrotron
LINAC
Cyclotron

The road map of higher power machine



Cyclotron (Isochronous)

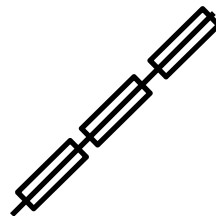

Linac

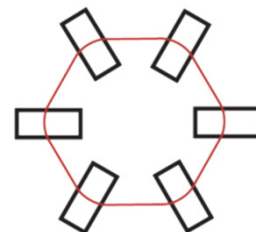

RCS

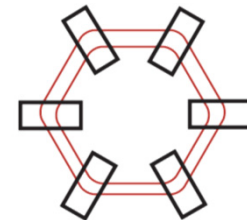

FFAG (Isochronous)

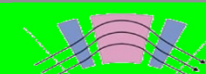
CW beam				
FF magnets				 $B_0(R) \propto \gamma(R)$
Fixed RF				
>1 GeV				



Cyclotron	RC Synchrotron	LINAC
Compact structure small footprint	Large footprint	Large footprint
Lower construction costs	Higher construction costs	Higher construction costs
High Energy Efficiency	Low Energy Efficiency	Low Energy Efficiency
Fixed Magnetic Field CW Beam Intensity up to a few mA	Varying magnetic field Low repetition rate Low average intensity	High energy SC LINAC Could be CW Theoretically up to 100mA
Isochronous Limitation Energy<1GeV	Easy to increase energy	Easy to increase energy

In the production of 5MW-10MW high power proton beam, both cyclotron (energy limited) and synchrotron (intensity limited) have obvious difficulties. The main view is that the feasibility of SC LINAC is higher. **But the high energy CW SC LINAC is still under development, And footprint (radiation shielding), energy efficiency, construction and operation cost.**

Summary

Beam power efficiency

- Beam power efficiency is an issue for high intensity accelerator.

$$BPE = \frac{\text{beam power (E} \times I_{\text{beam}})}{\text{total operational power}}$$

- **BPE > 30%** for $P_b > 10\text{MW}$, otherwise
 - Environment problem: CO₂
 - ADSR becomes nonsense ; Creating nuclear wastes more than treating!
- Superconducting magnet
 - High temperature SC is very attractive.



The Energy Efficiency of High Intensity Proton Driver Concepts

Vyacheslav P. Yakovlev

The 8th International Particle Accelerator Conference – IPAC'17

19 May 2017



Cyclotron

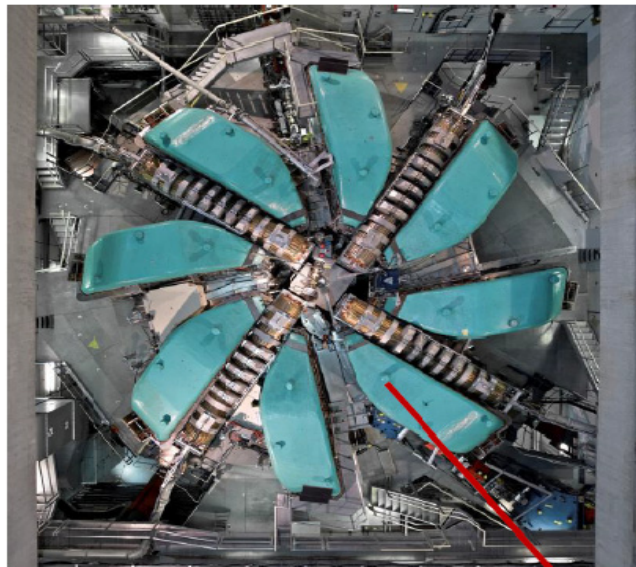
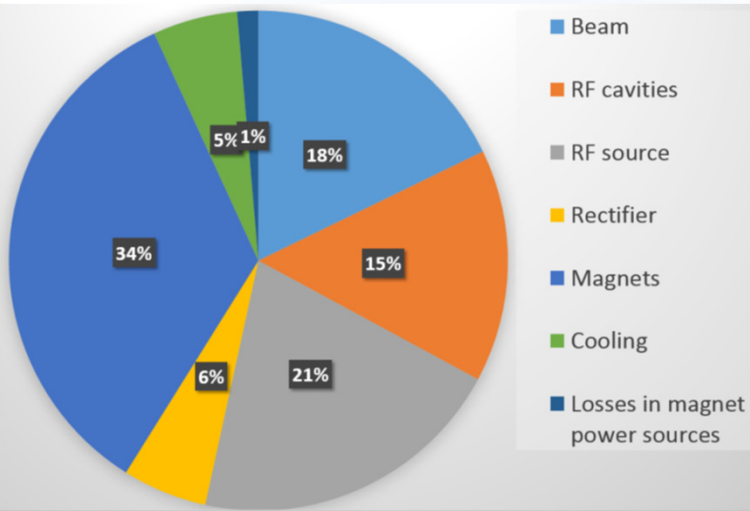

Ring Cyclotron: 590 MeV
 2.4 mA
 1.4 MW
 186 turns
 8 sector magnets

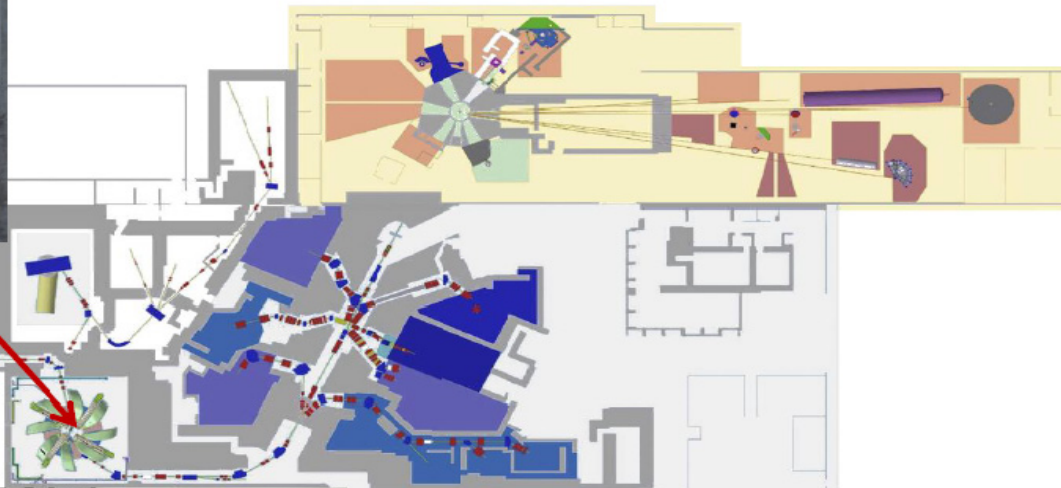

Cockcroft-Walton: 10 mA, 870 keV

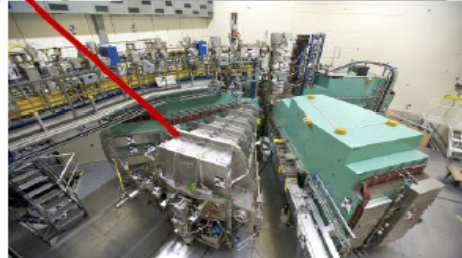

Injector 2: 2.7 mA, 72 MeV

Total power of PSI Cyclotron ~8MW , 1.4 MW proton beam, **beam/grid efficiency: 18%, after upgrade: 24%**

SC LINAC

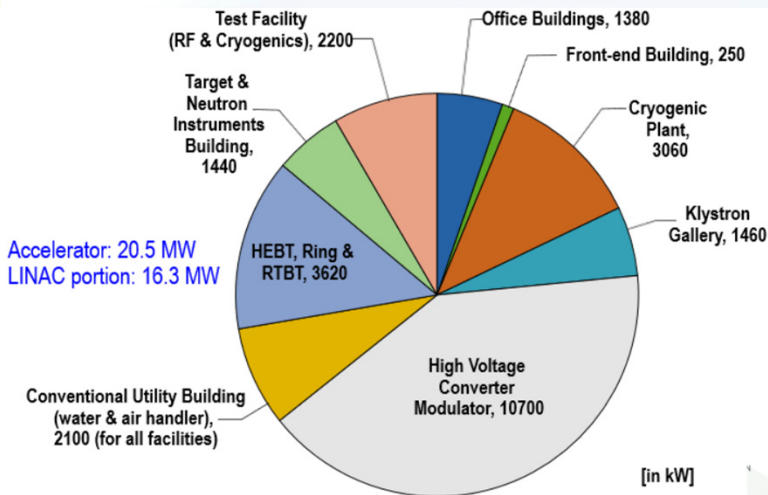

□ Total power of SNS LINAC ~16.3MW , 1.4 MW proton beam, **beam/grid efficiency: 8.6%**

LINAC+RCS

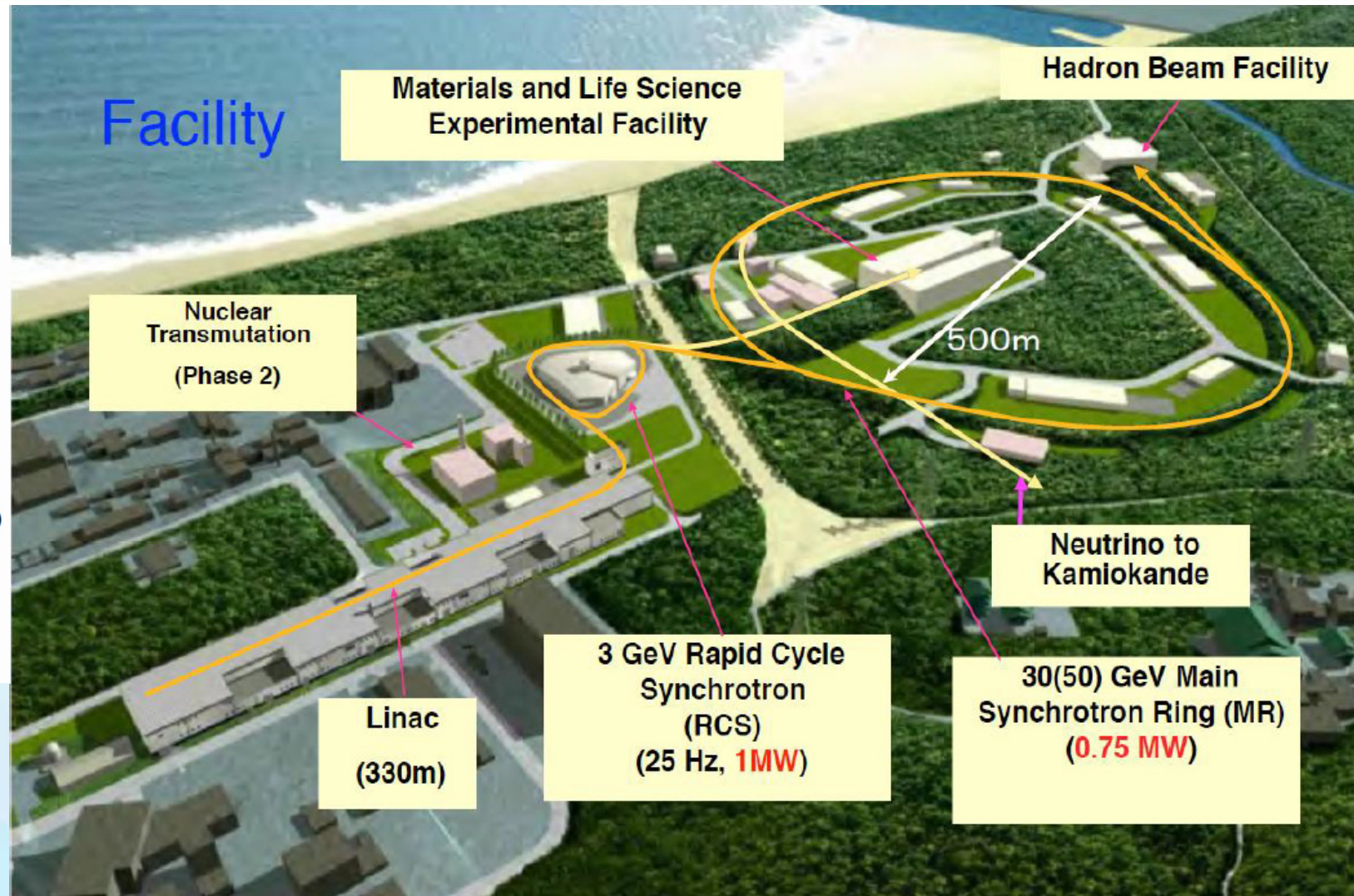
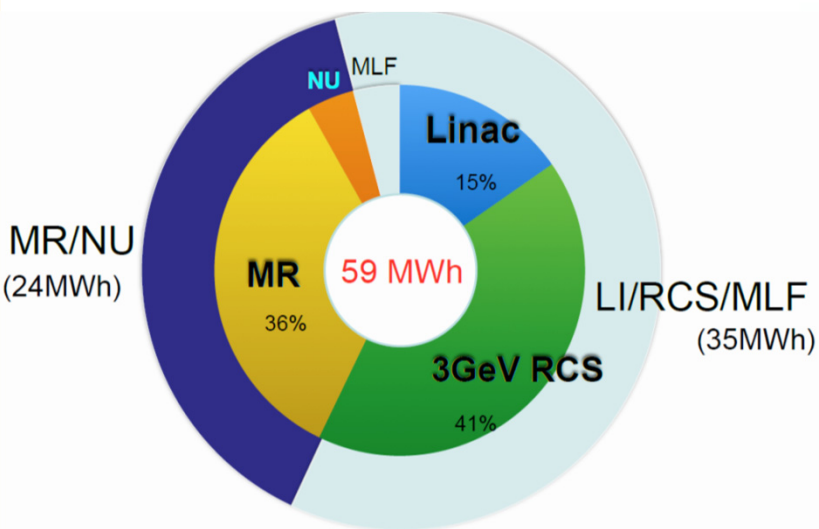

□ The power of LINAC+3GeV RCS in JPARC~32.6MW , 1 MW proton beam, beam/grid efficiency: 3%

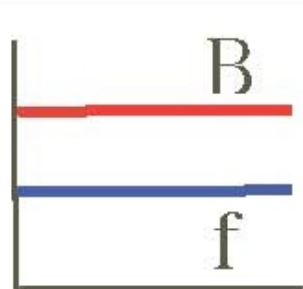

accelerating time

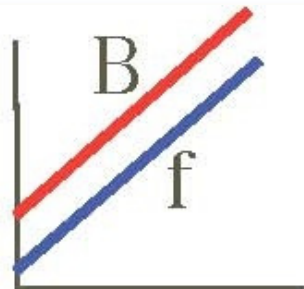

accelerating time

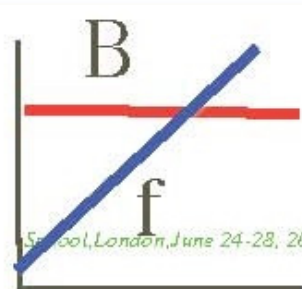

accelerating time

St. Paul, London, June 24-28, 20002



Cyclotron
*isochronous



Synchrotron
*const. closed orbit
(varying mag. field)



FFAG
*varying closed orbit
(const. mag. field)



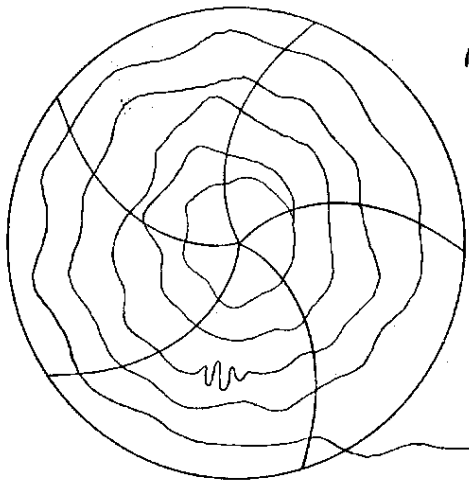
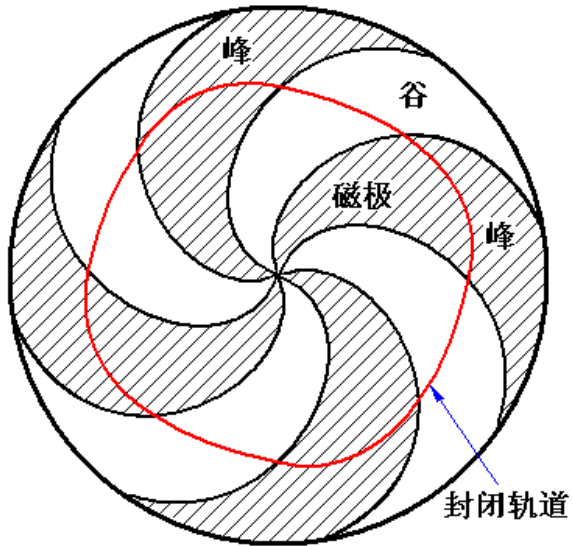

$$r = r_0 \left[1 + \left(\frac{fr\omega}{c} \right) \cos(3\theta + \delta_0 + \delta_1 r) + \left(\frac{fr\omega}{c} \right)^2 \cos(5\theta + \delta_2 - \delta_3 r^2) + \left(\frac{fr\omega}{c} \right)^3 \cos(7\theta + \delta_4 - \delta_5 r^3) + \dots \right] \times \left\{ \frac{e^{1/2} r^2 \ln Z}{1 + (\frac{r}{r_0})^{3/2}} \right\}$$

$$\frac{d\theta}{dt} = \left[\sin(\omega t - h\theta) - \sin h\theta - \frac{3}{5} f f' f' f' \right] \frac{eV_0}{2\pi} \omega$$

Cyclotron: FF, Ff

Problem: Rapid Cycling

Ff

Challenge: Isochronism for Higher Energy, Tune Diagram

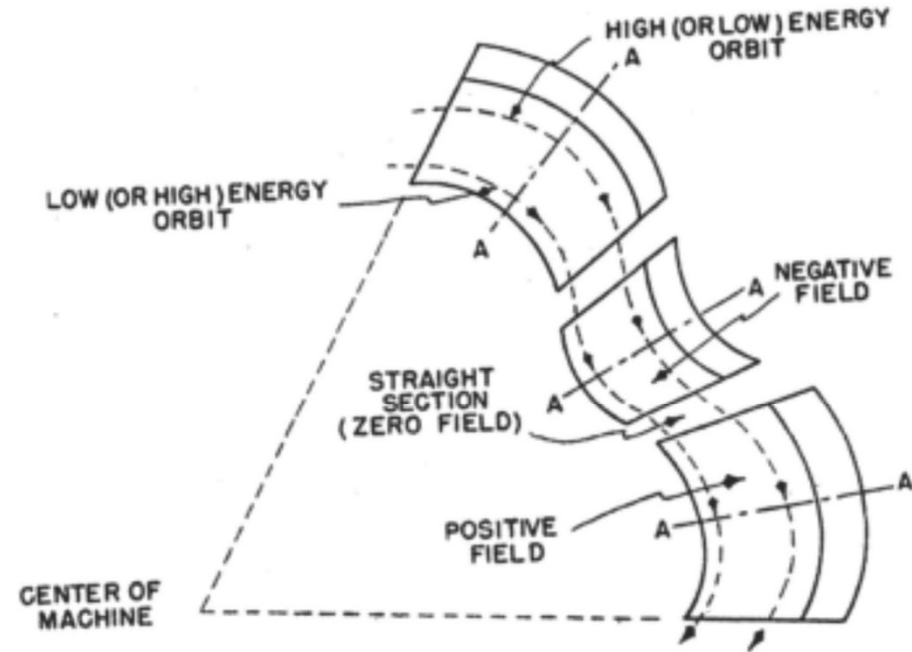

negative k: the orbit go inner during acceleration

FFAG: FF, ~~Ff~~, Rapid Cycling

A high-order varying radial gradient of the field and FFAG Lattice are introduced to obtain isochronism at higher energy

A high-order varying radial gradient of the field and turn diagram adjustment in cyclotron are introduced to obtain CW FFAG

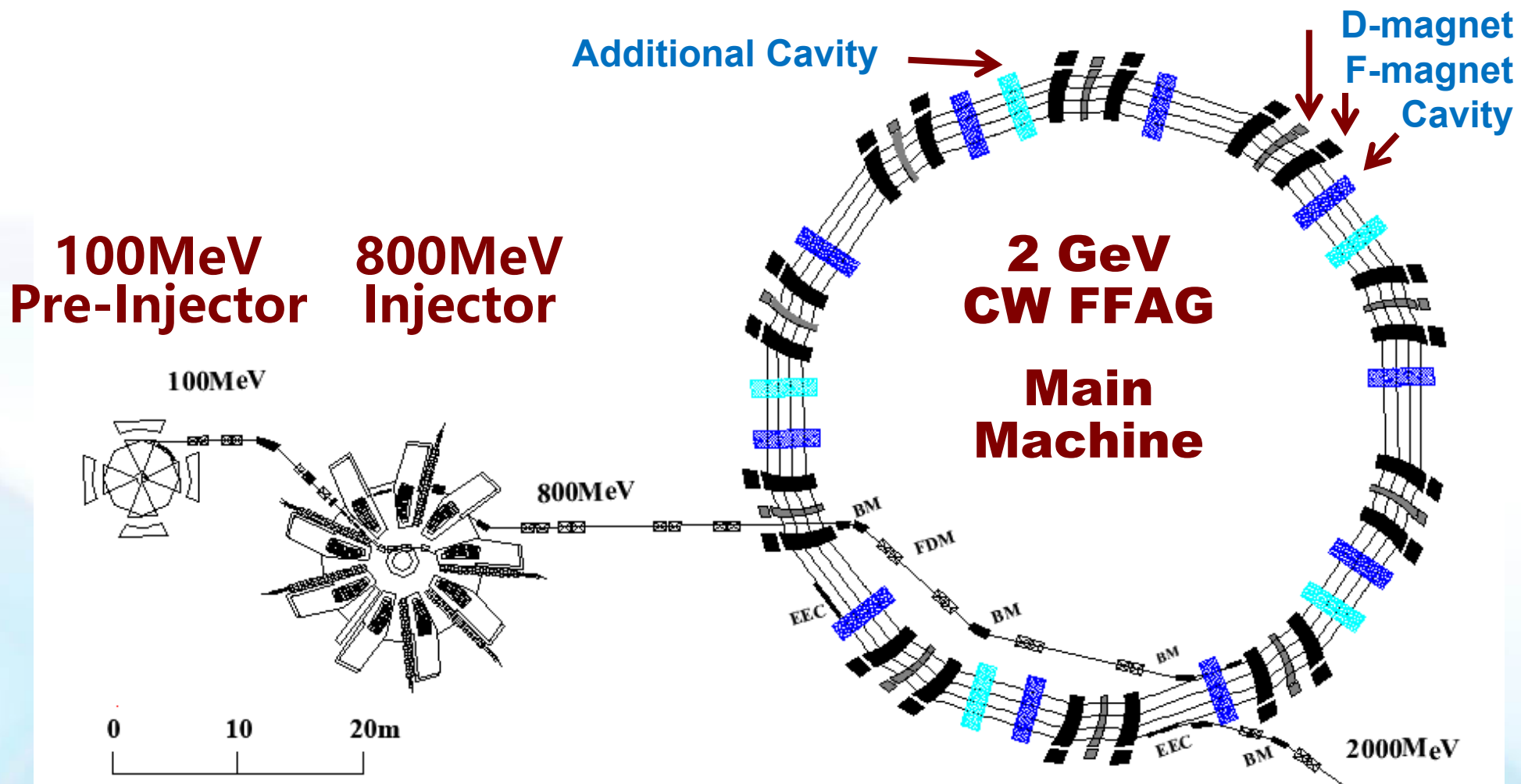

Goal: 2GeV, 3mA, 6MW CW Proton Beam

2 GeV CW FFAG

Comparing with an isochronous cyclotron, the 3rd order varying radial gradient of the magnetic field and FFAG's FDF Lattice are introduced to obtain isochronism at higher energy and bigger transverse acceptance.

The two 3rd order field distributions, combining with the traditional spiral angles, angular widths and the fringe field shimming of the F & D magnets, bring more degrees of freedom to realize the isochronism and optimize the tune in the diagram.

More than 9 meters straight drift for the installation of up to 10 RF cavities to increase the energy gain per turn to 10 MeV, and for the beam injection /extraction.

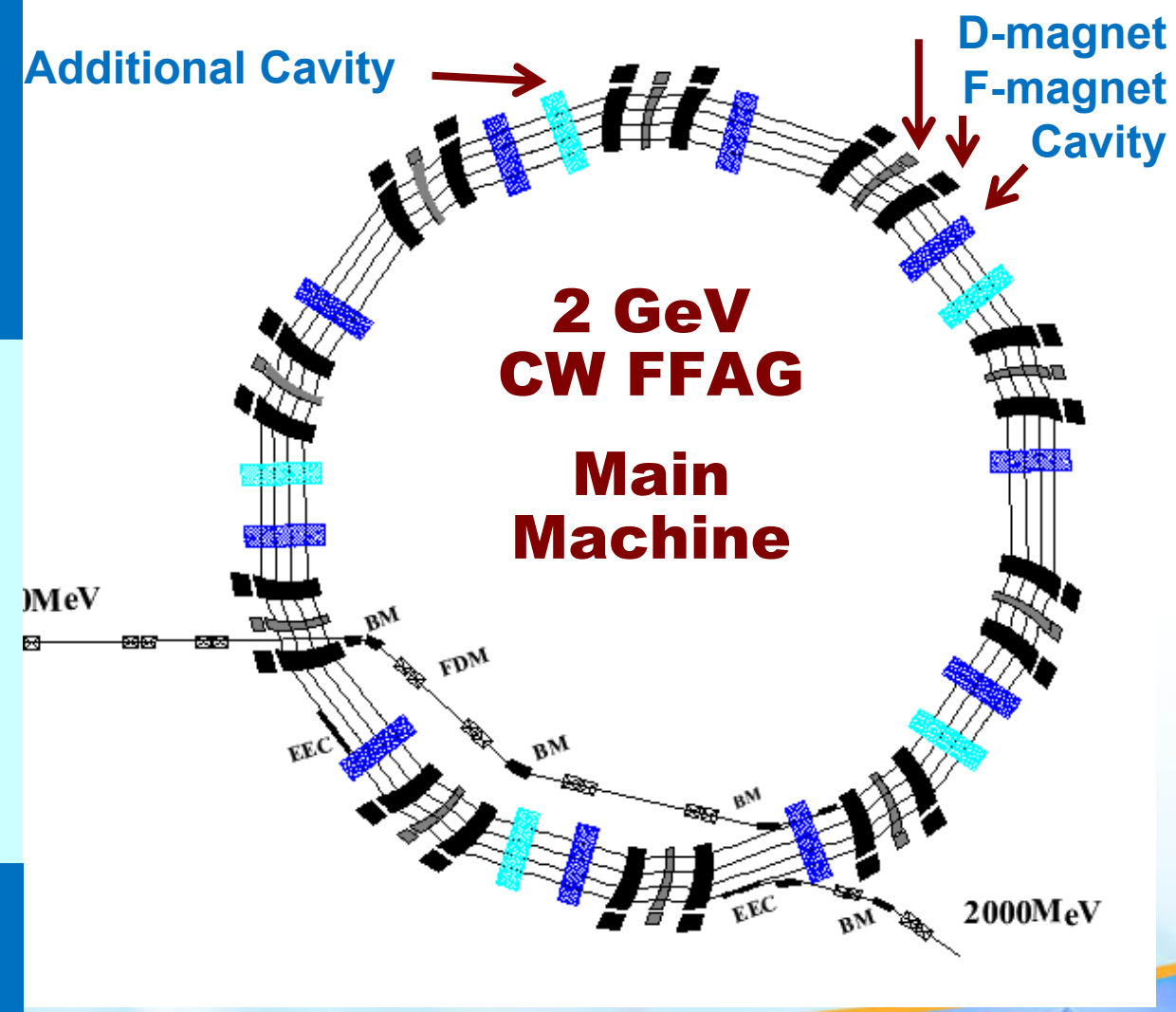

10 MeV CW Proton Beam

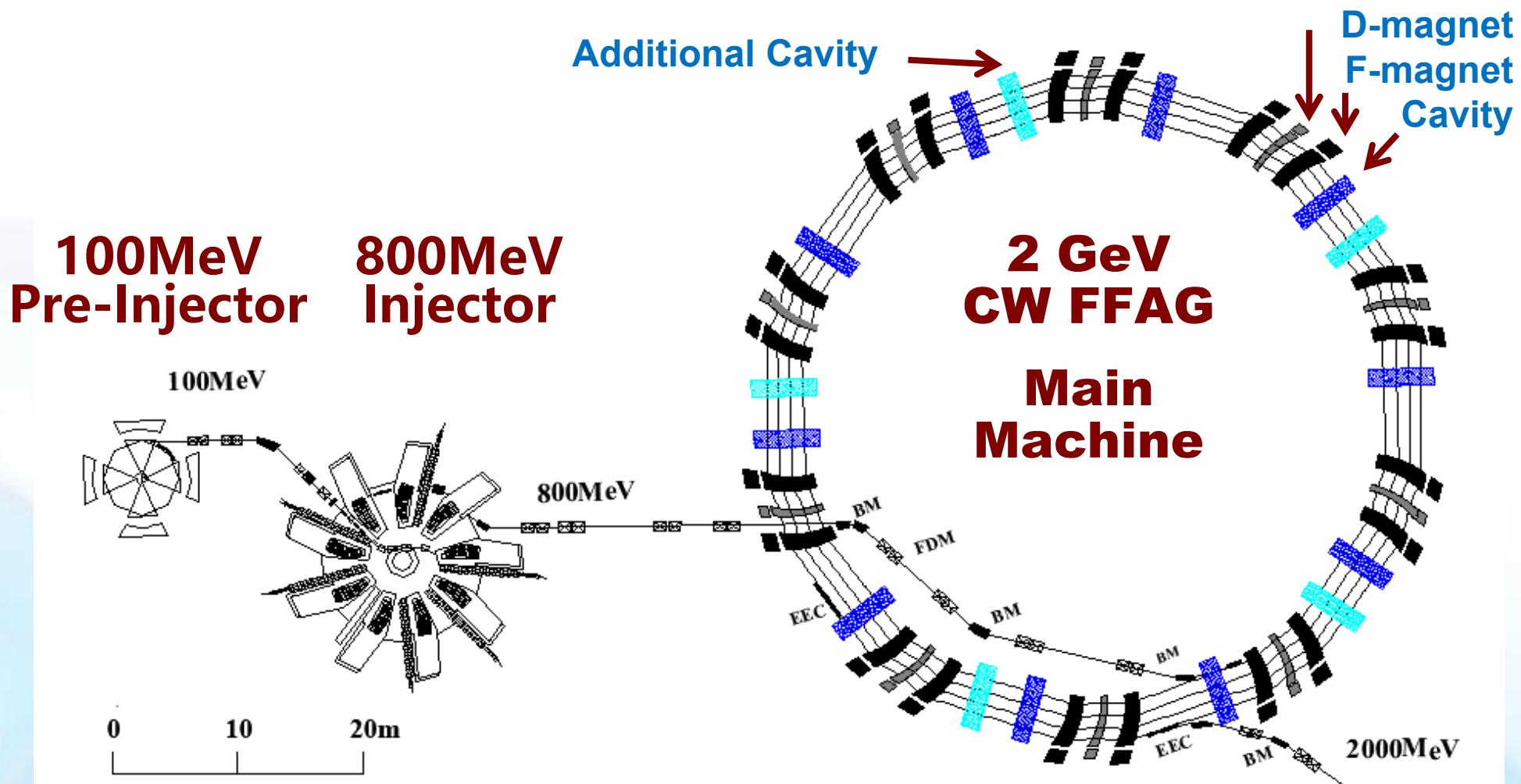

Goal: 2GeV, 3mA, 6MW CW Proton Beam

The 10 cell magnets and 10 RF cavities are arranged strictly in 10-fold symmetry to avoid driving low-order resonance.

From the PSI's experience, the beam intensity, dominated by the space charge, is proportional to the third power of the energy gain per turn[8]. Based on that, the beam intensity is $\sim 6\text{mA}$ for 10 MeV energy gain per turn & big transverse acceptance of FFAG.

It is conservatively estimated to be 3mA for this design.

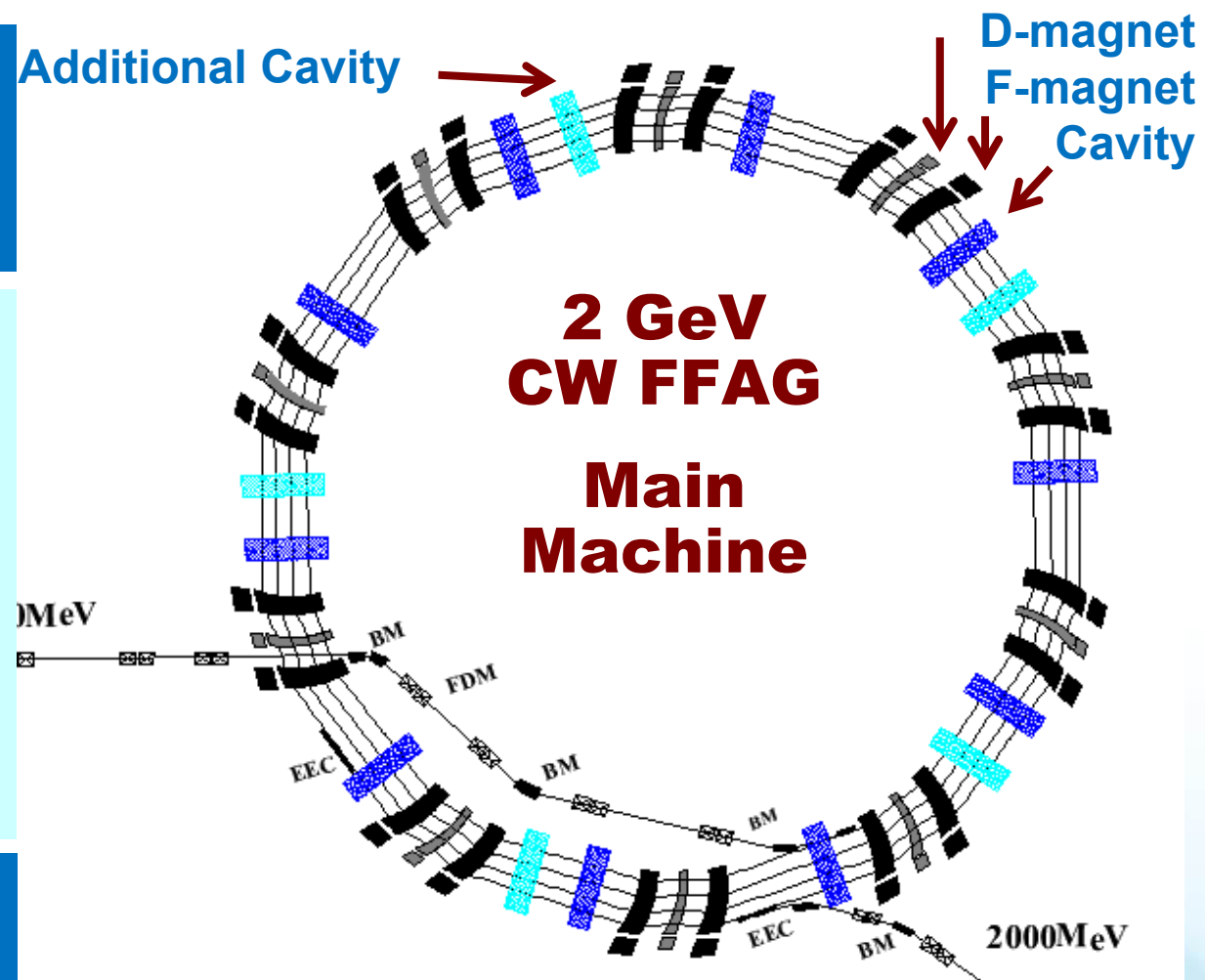

Goal: 2GeV, 3mA, 6MW CW Proton Beam

General Design, and R & D activities are conducted for a 2 GeV isochronous FFAG recently

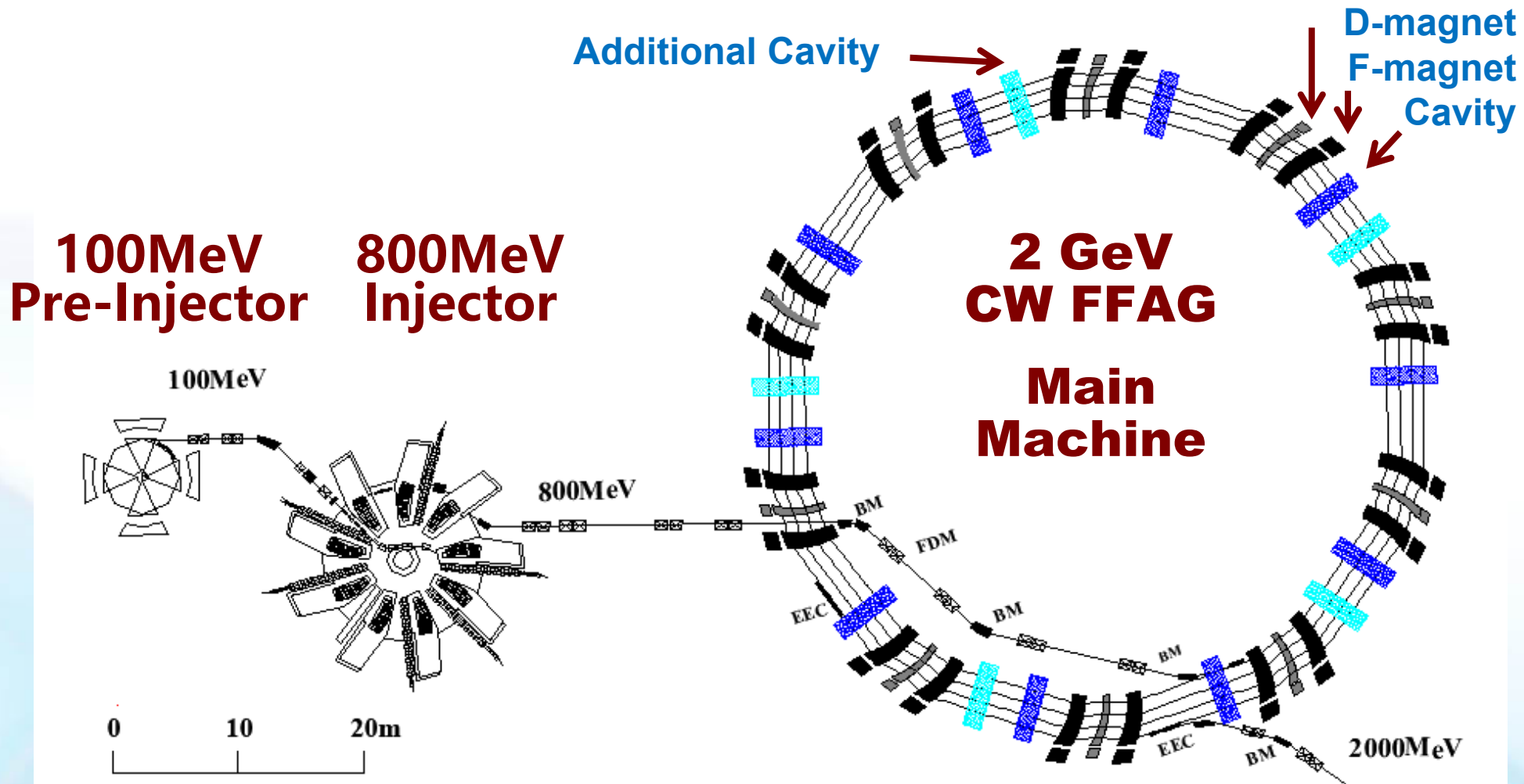

Goal: 2GeV, 3mA, 6MW CW Proton Beam

Accelerator	100 MeV Pre-Injector	800 MeV Injector	2 GeV FFAG
Type	Separated-sector cyclotron	Spiral-sector cyclotron	CW FFAG
Overall diameter (m)	6.1	16	54
Lattice structure	FO	FO	QFoDoFO
Magnet Type	Warm	Warm	HTS
Average field(T)	0.36~0.41	0.54~0.90	F:1.5~2.7 / D:1.0~2.4
Sector number	4	9	10
Main cavity number	2	5	10
Cavity type	Double gap	Single gap	Single gap
RF Frequency(MHz)	44.4	44.4	44.4
Harmonic number	4	6	26
RF peak voltage(kV)	500	800~1000	~1200



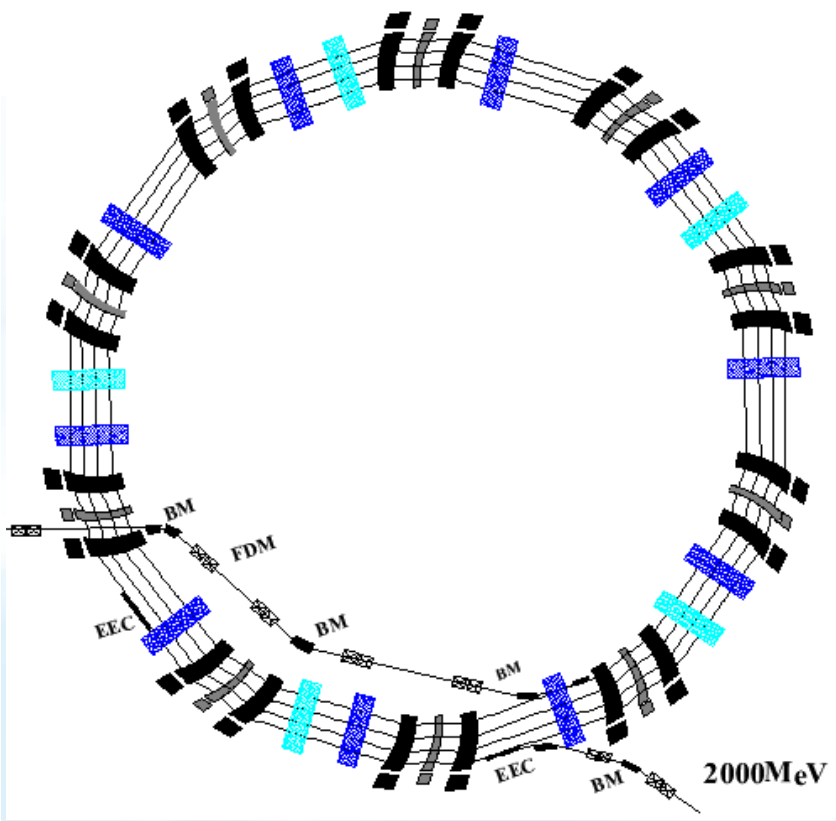
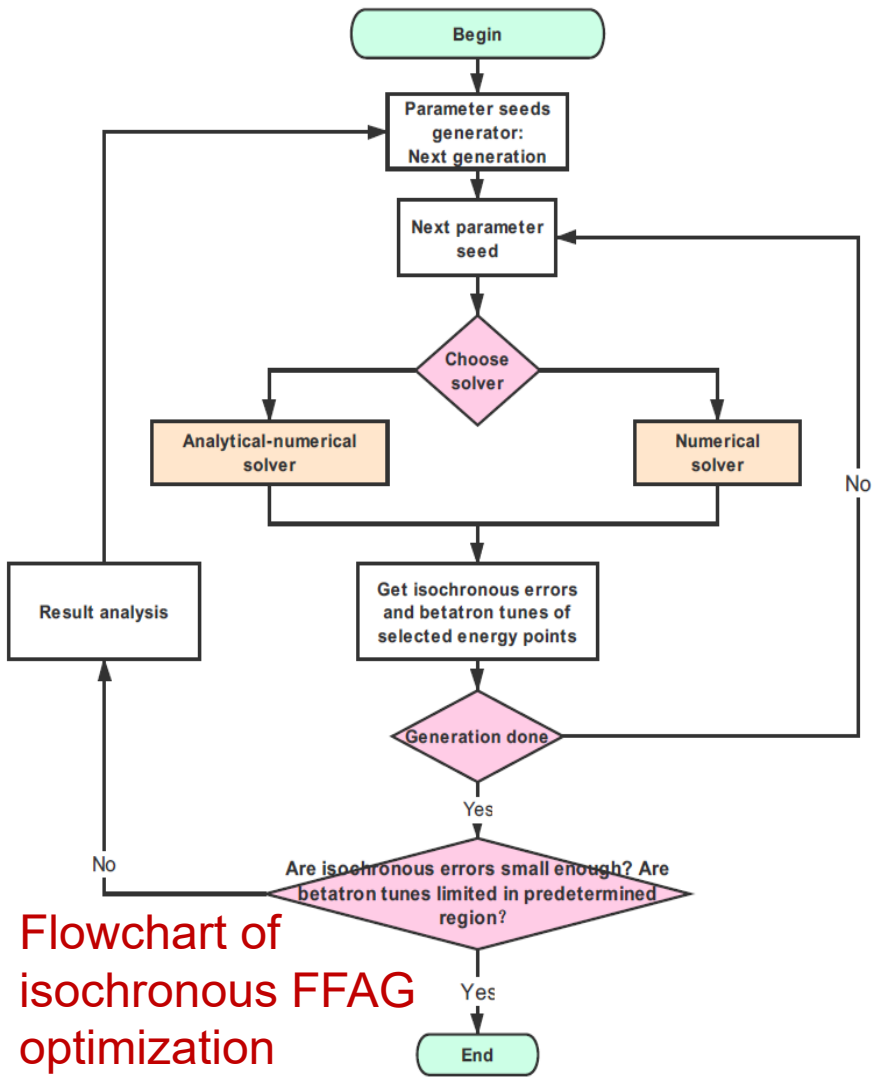

$$B_f = 0.4221 * (r - 23.5)^3 - 1.7247 * (r - 23.5)^2 + 4.7565 * (r - 23.5) + 14.8348$$

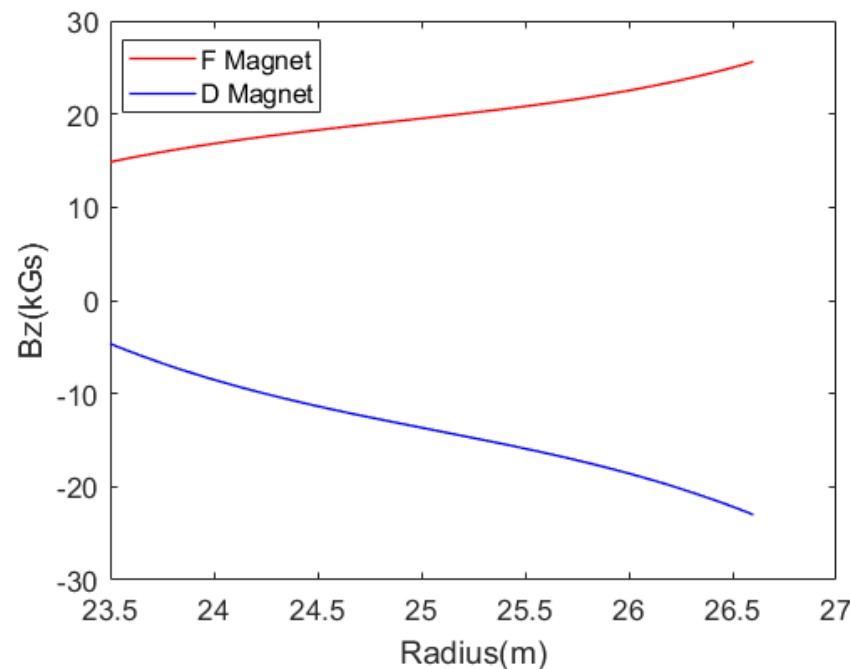

$$B_d = -0.6386 * (r - 23.5)^3 + 2.9921 * (r - 23.5)^2 - 9.0592 * (r - 23.5) - 4.6466$$

Developed a multi-objective optimization code, by using beam dynamics solver and parallel genetic algorithm to achieve **FDF** magnetic structure for high energy isochronous acceleration.

2 GeV CW FFAG

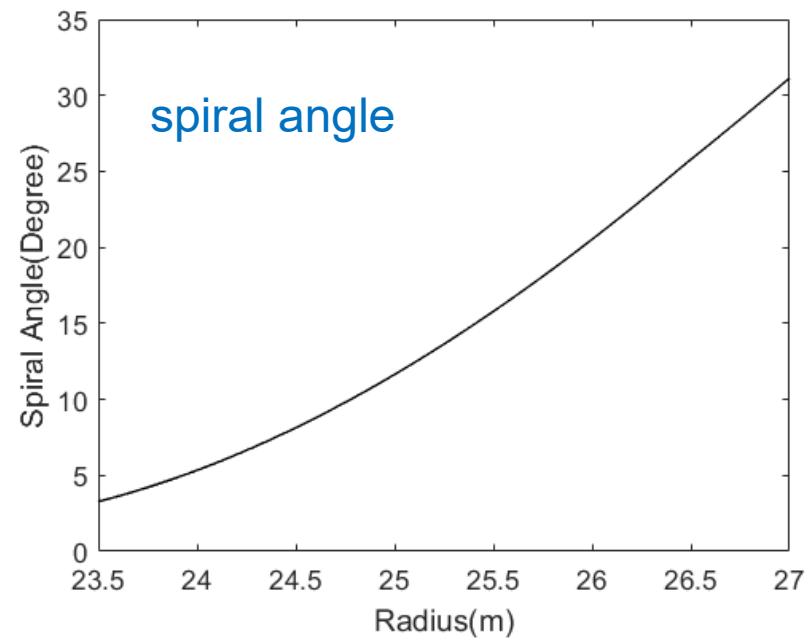
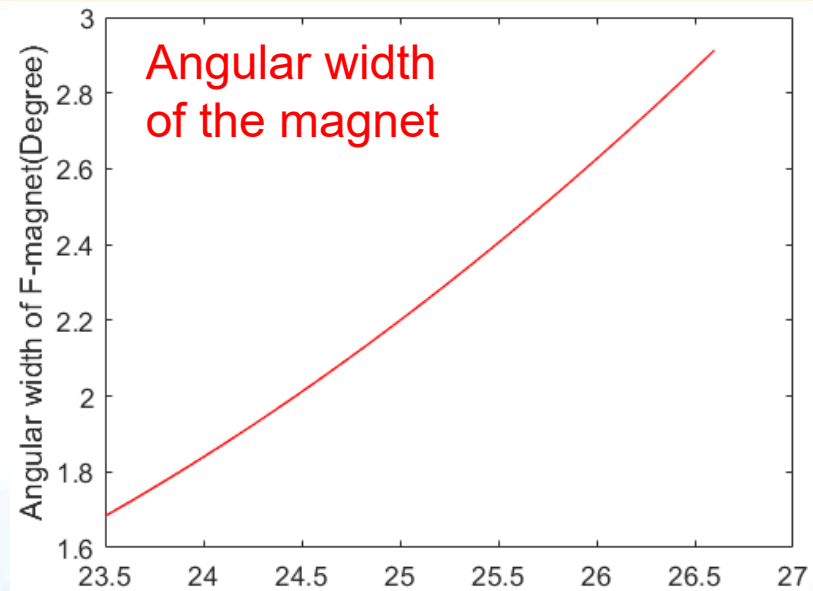
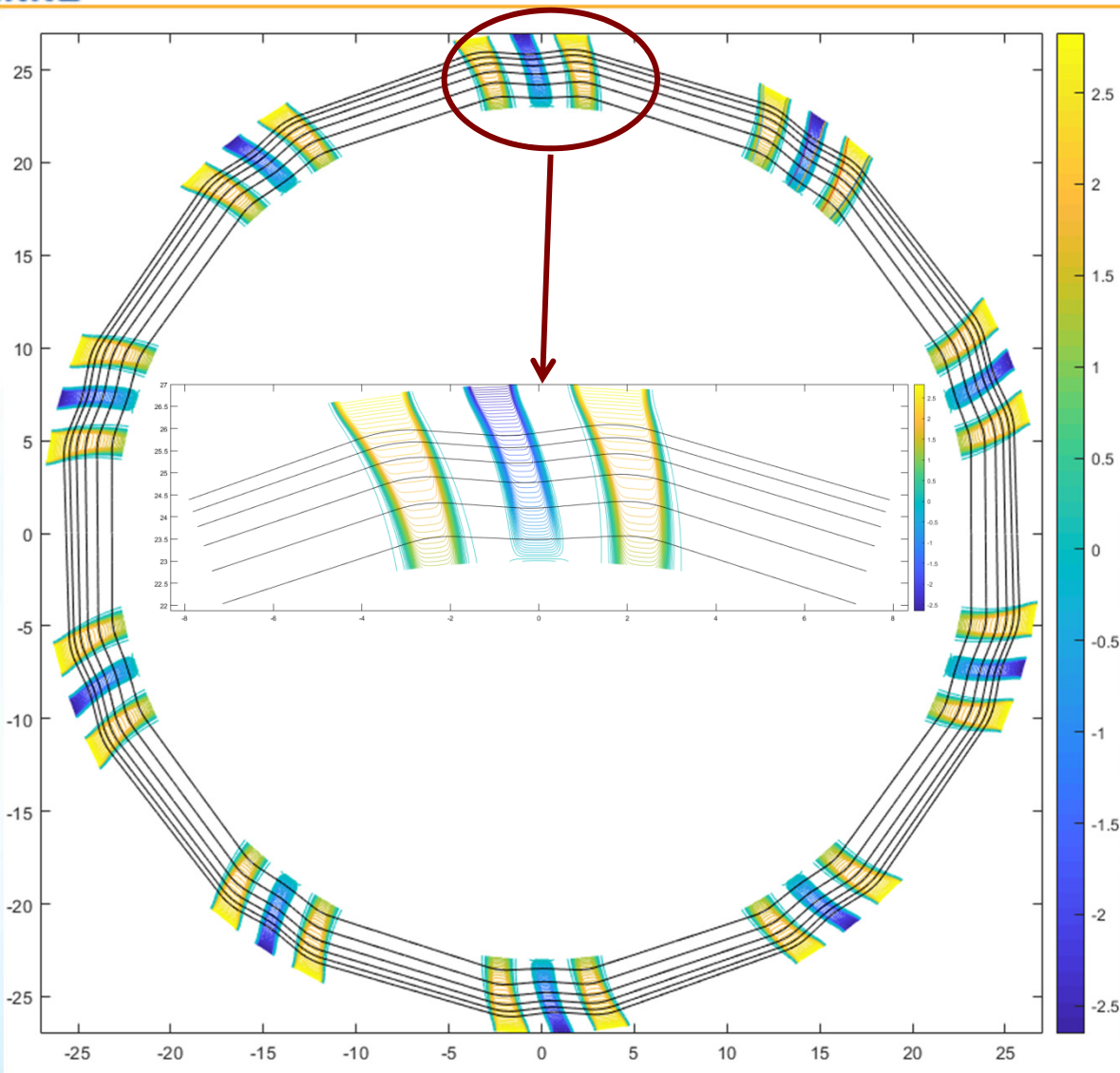

$$B_z(r, x, 0) = B_s(r)h(x) = B_s \frac{1}{1 + \exp(c_0 + c_1x + c_2x^2 + c_3x^3 + c_4x^4 + c_5x^5)}$$

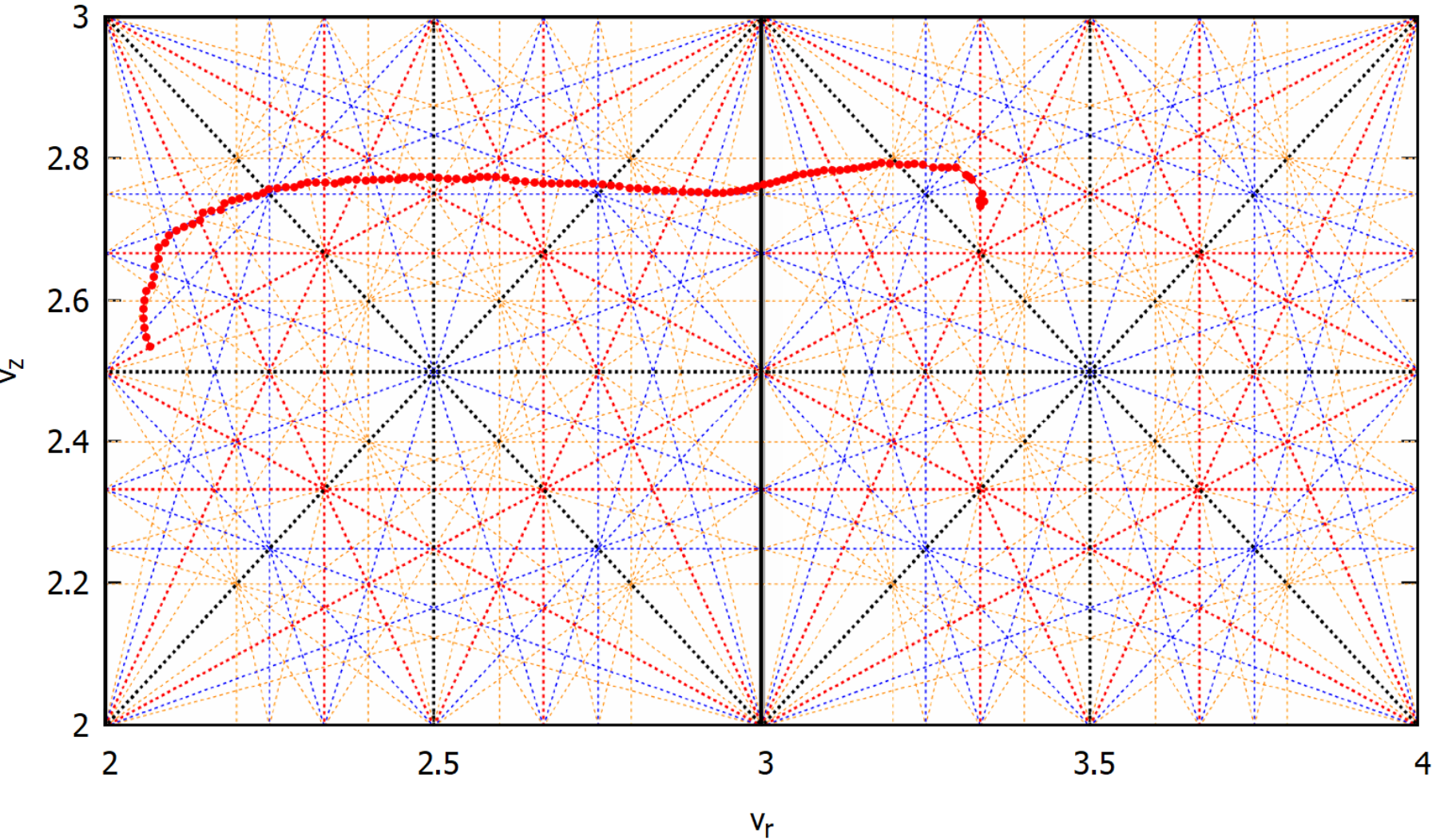

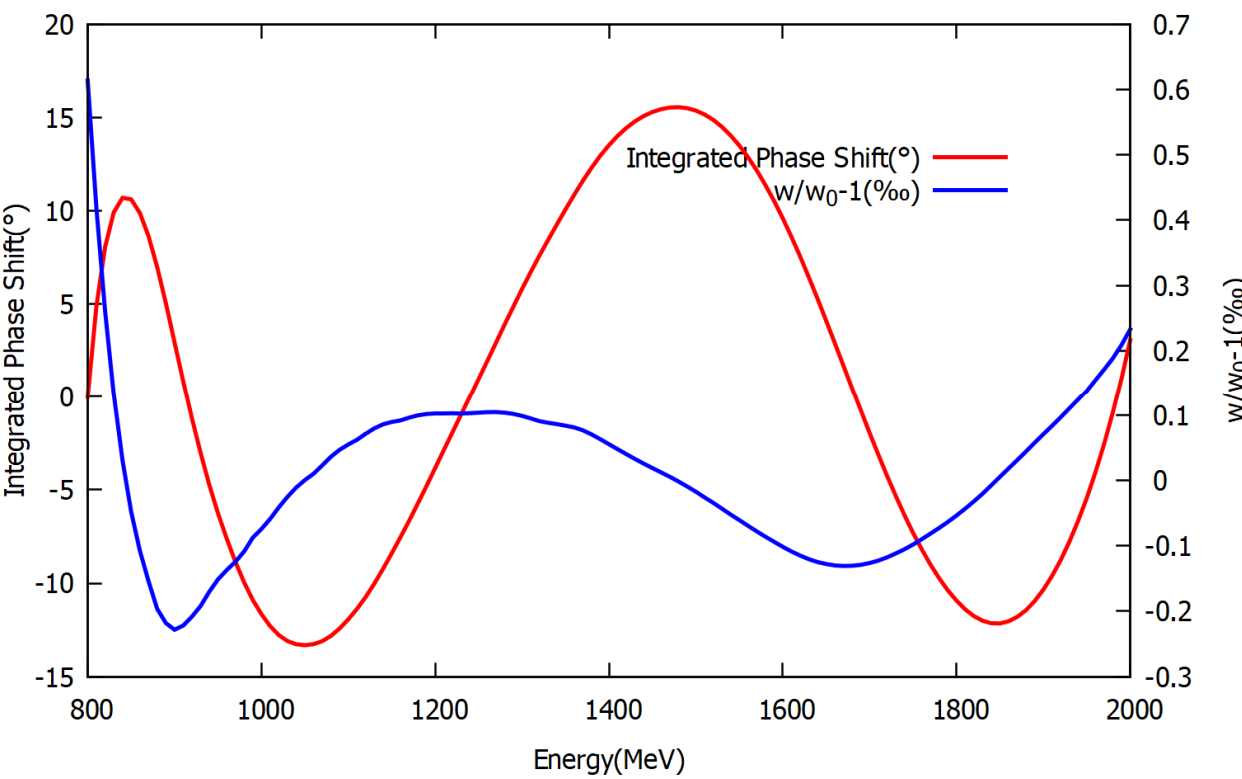
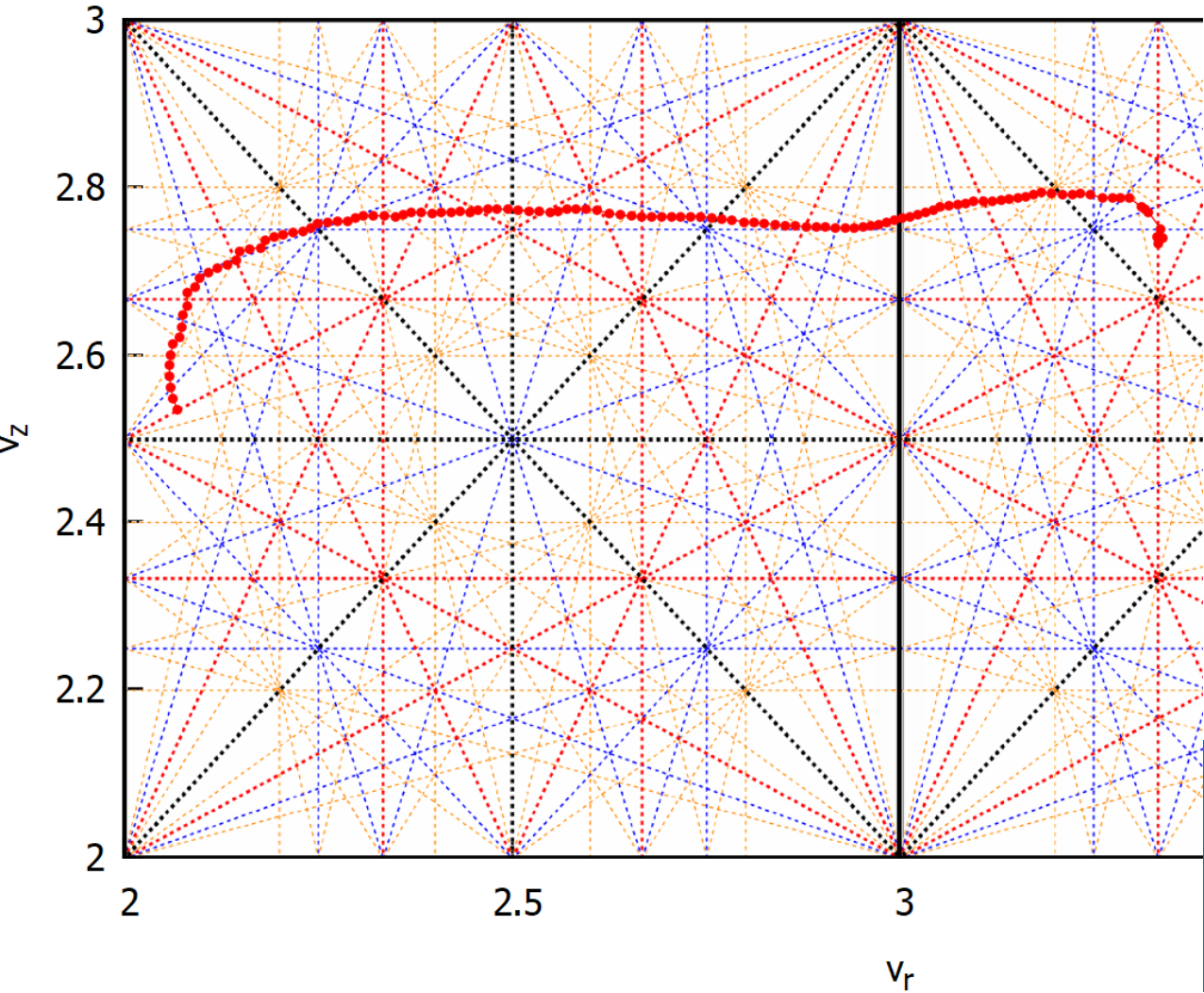

800 MeV to 2 GeV, Phase Shift
 Integrated Phase Shift $< \pm 15^\circ$
 Local Phase Shift $< \pm 2.5E-4$



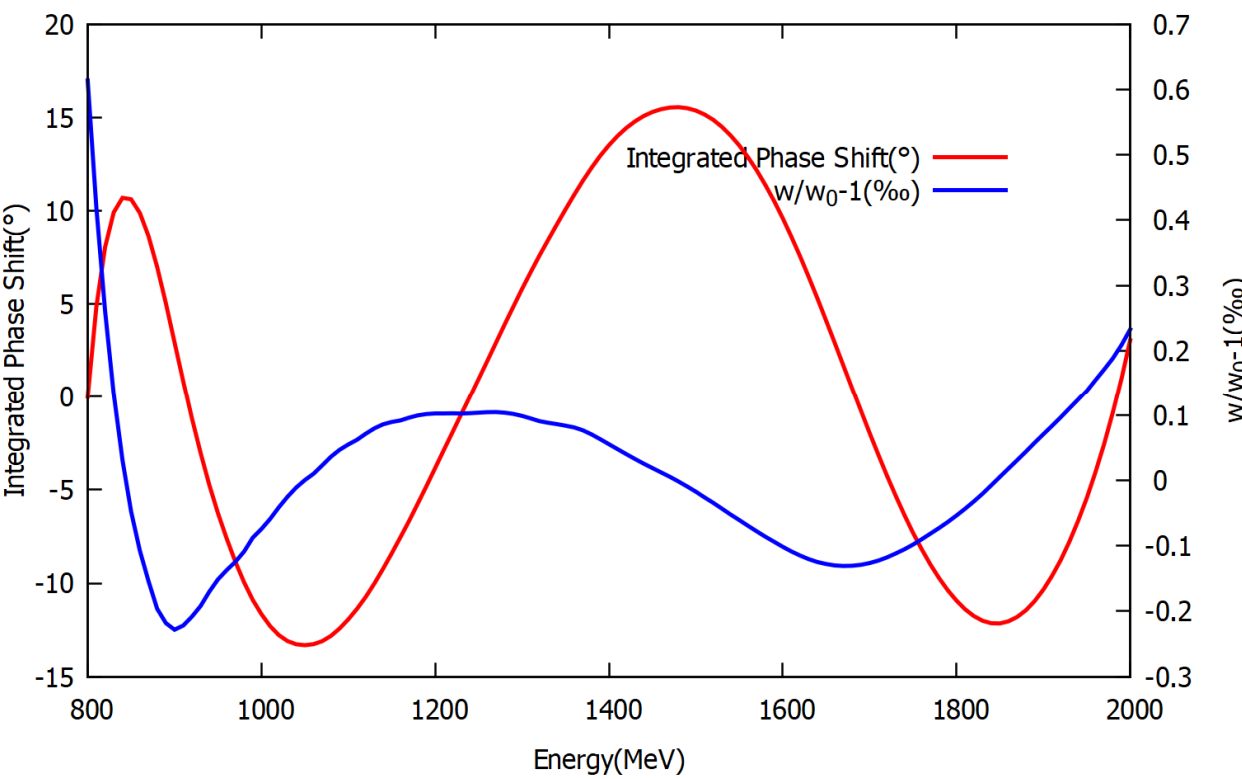
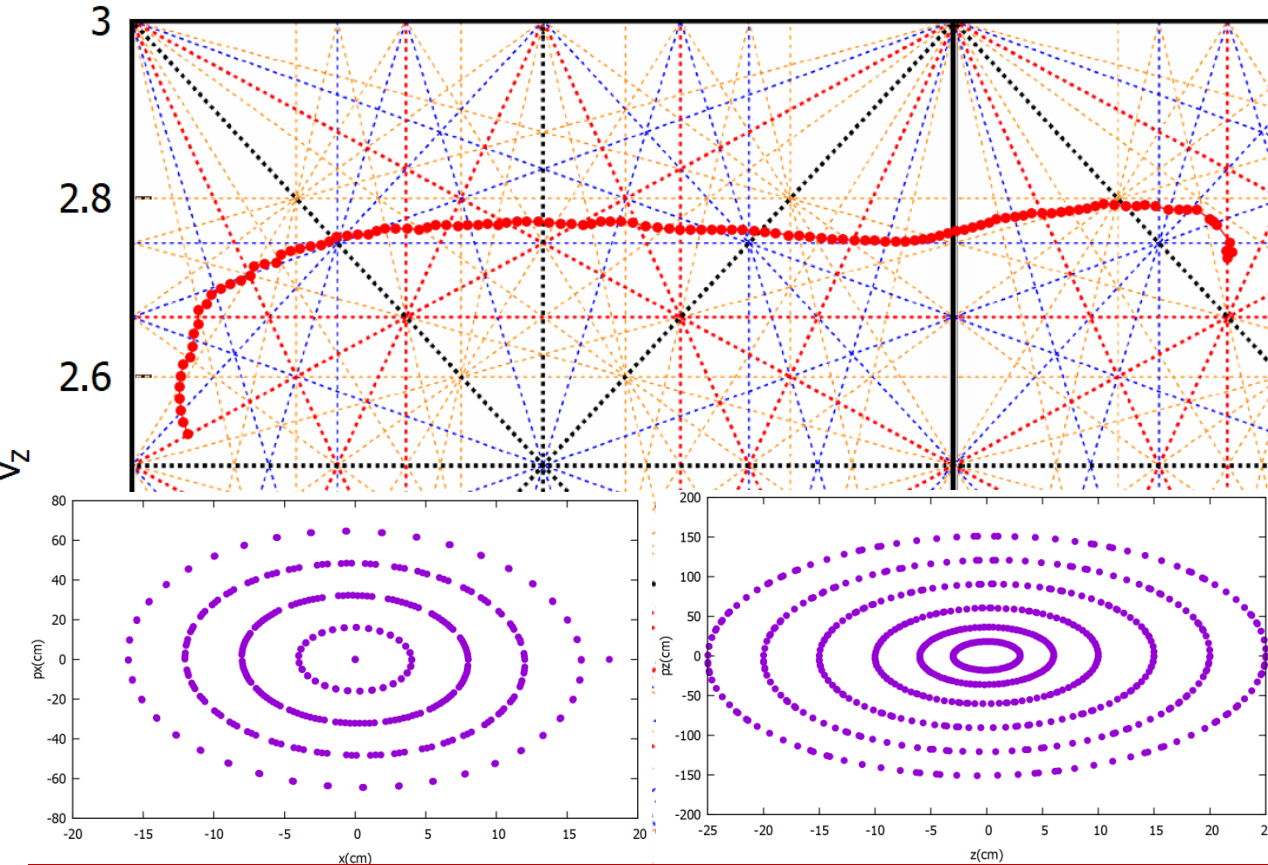

The radial (left) and vertical (right) phase space at 800MeV

800 MeV to 2 GeV, Phase Shift
 Integrated Phase Shift $< \pm 15^\circ$
 Local Phase Shift $< \pm 2.5E-4$



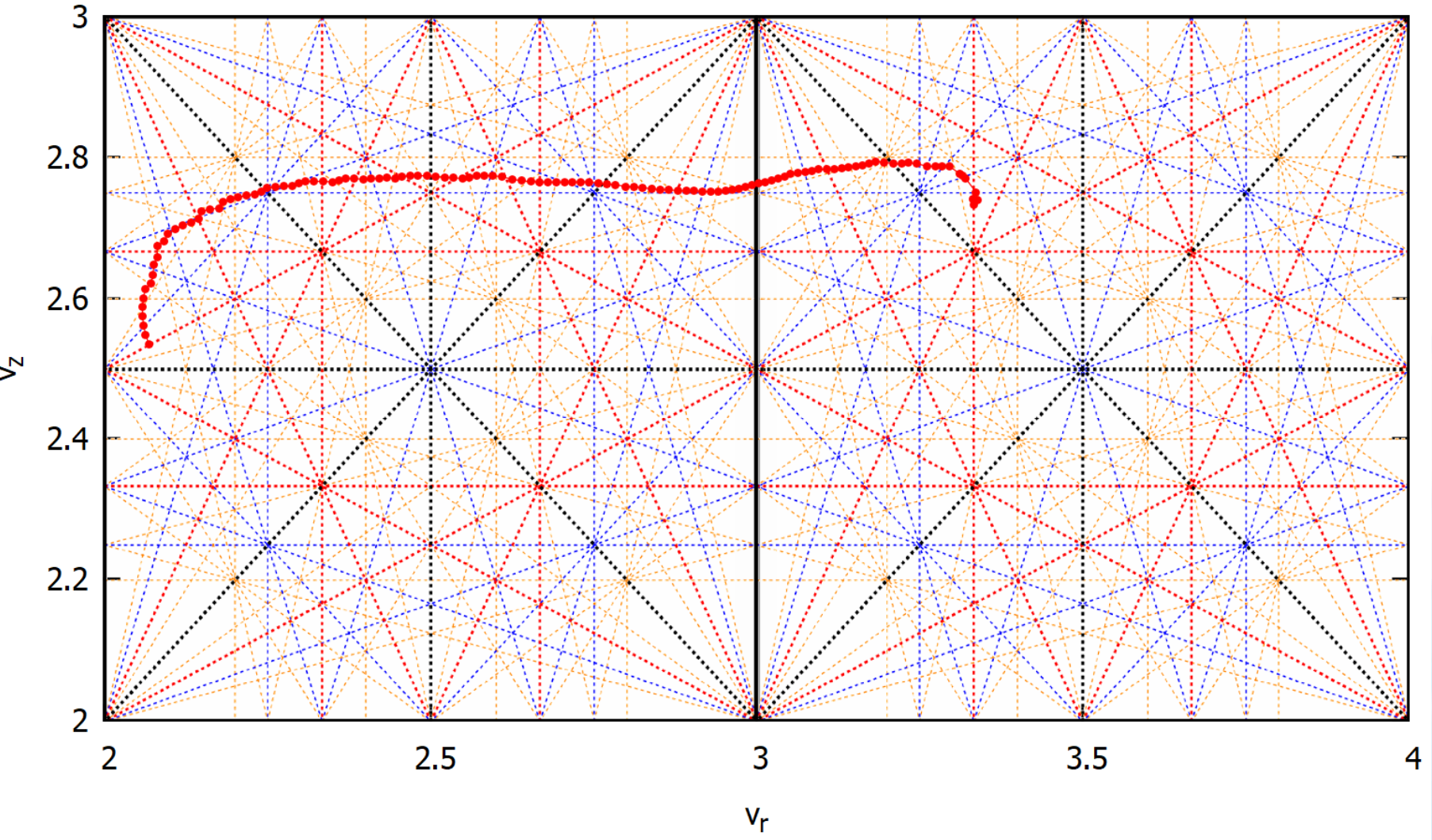

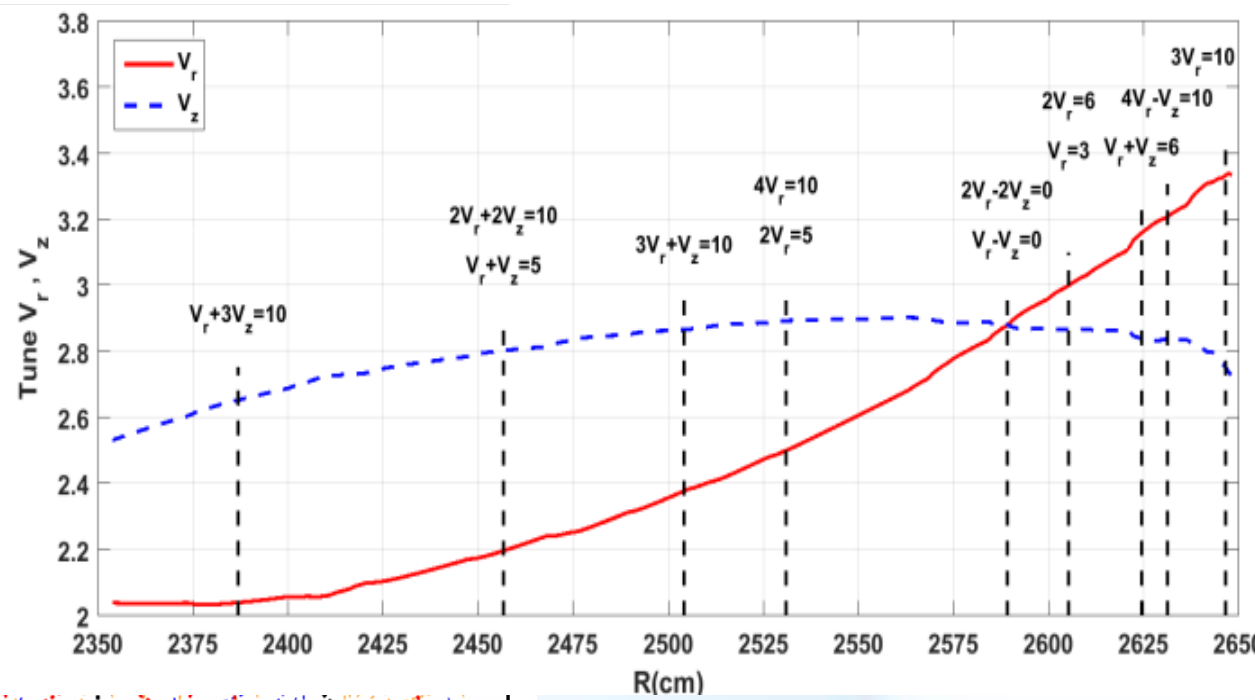
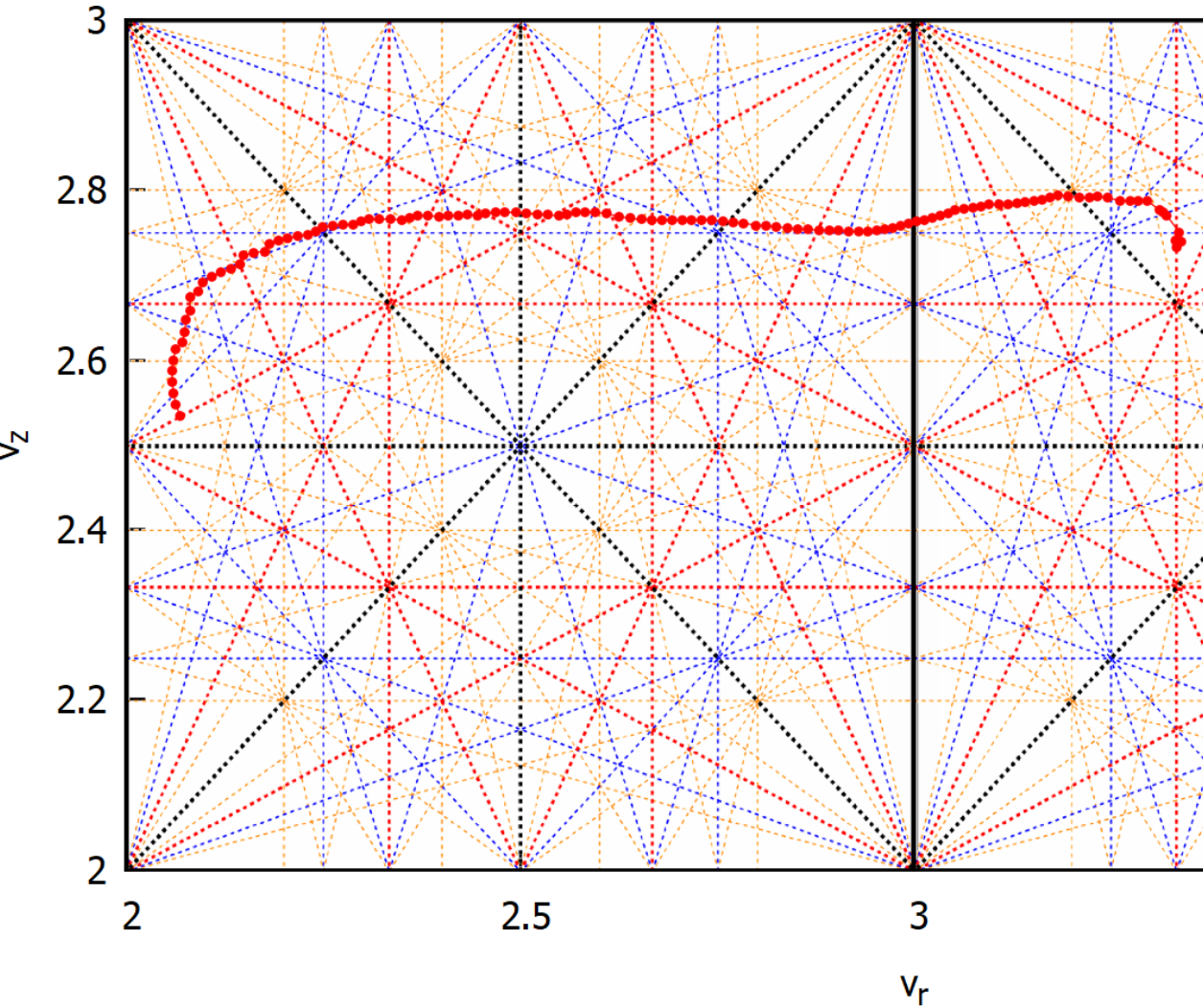

- Among these resonances, the first order resonance $\nu_r=3$, driven by third harmonic field B_3 , is the most sensitive.
- The other one is the $2\nu_r=5$ resonances



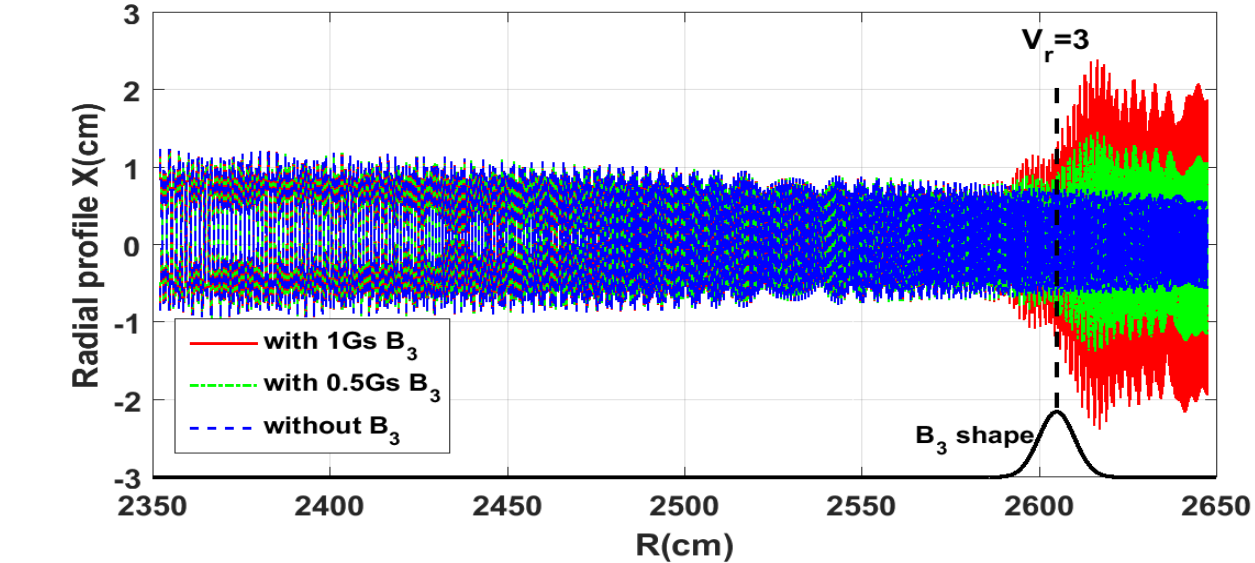
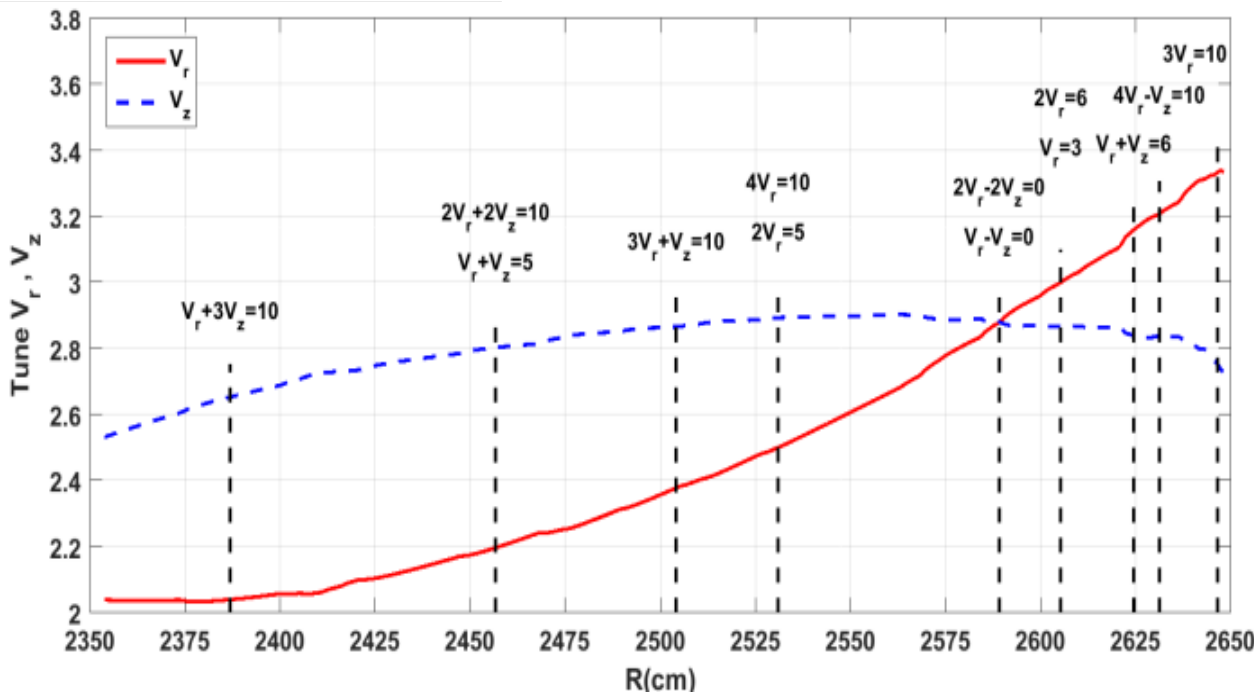
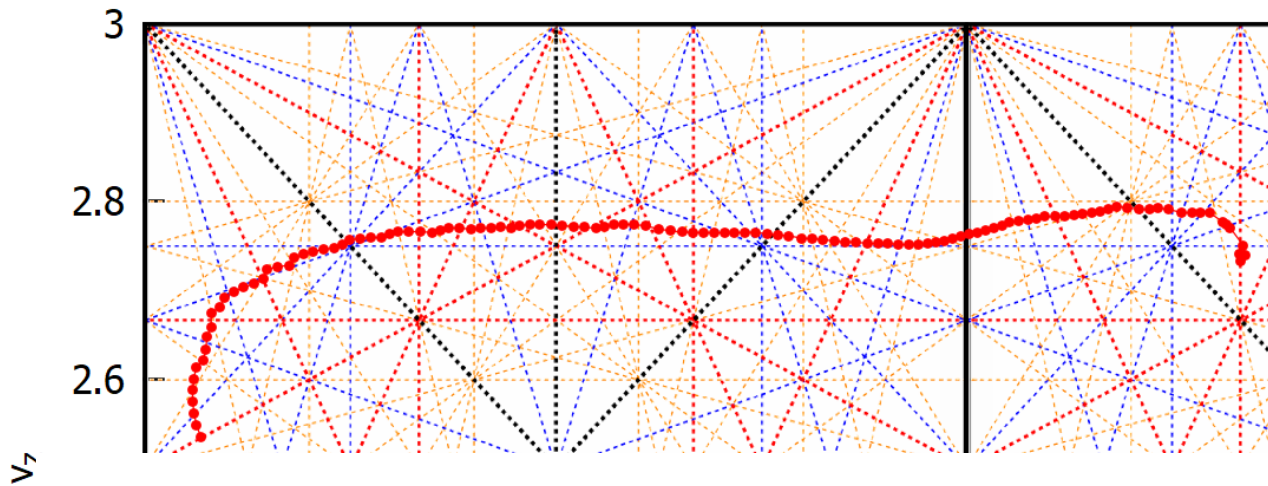

- Among these resonances, the first order resonance $\nu_r=3$, driven by third harmonic field B_3 , is the most sensitive.
- The other one is the $2\nu_r=5$ resonances

Resonance $\nu_r=3$

$B_3=1$ Gs More study needed

There is a risk due to resonance $\nu_r=3$. We expect that the energy gain per turn of 15 MeV will make the resonance crossing fast

Fundamental consideration for the **extraction**, emphasizing on the turn separation, are investigated preliminarily

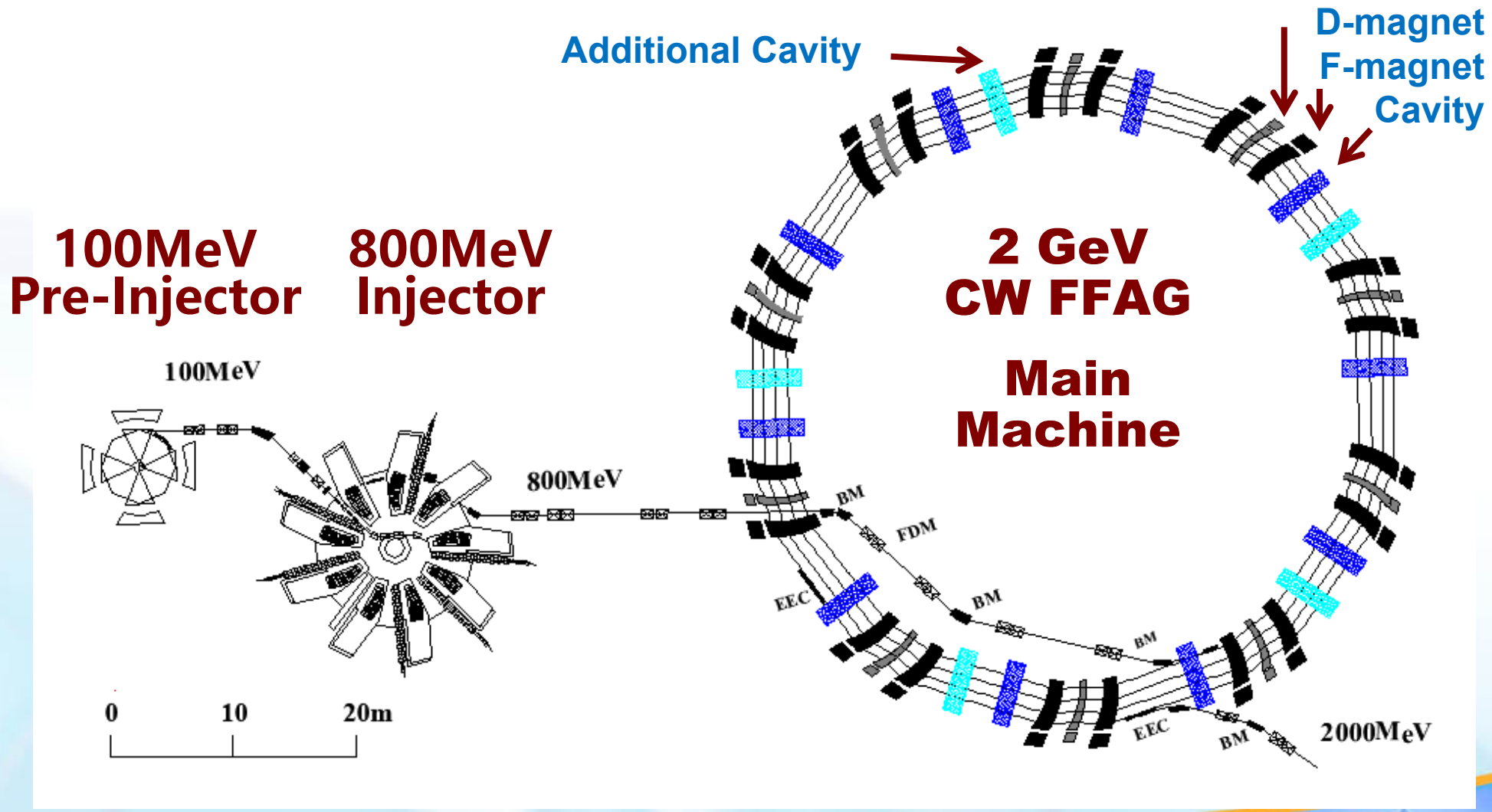

Goal: 2GeV, 3mA, 6MW CW Proton Beam

Fundamental consideration for the **extraction**, emphasizing on the turn separation

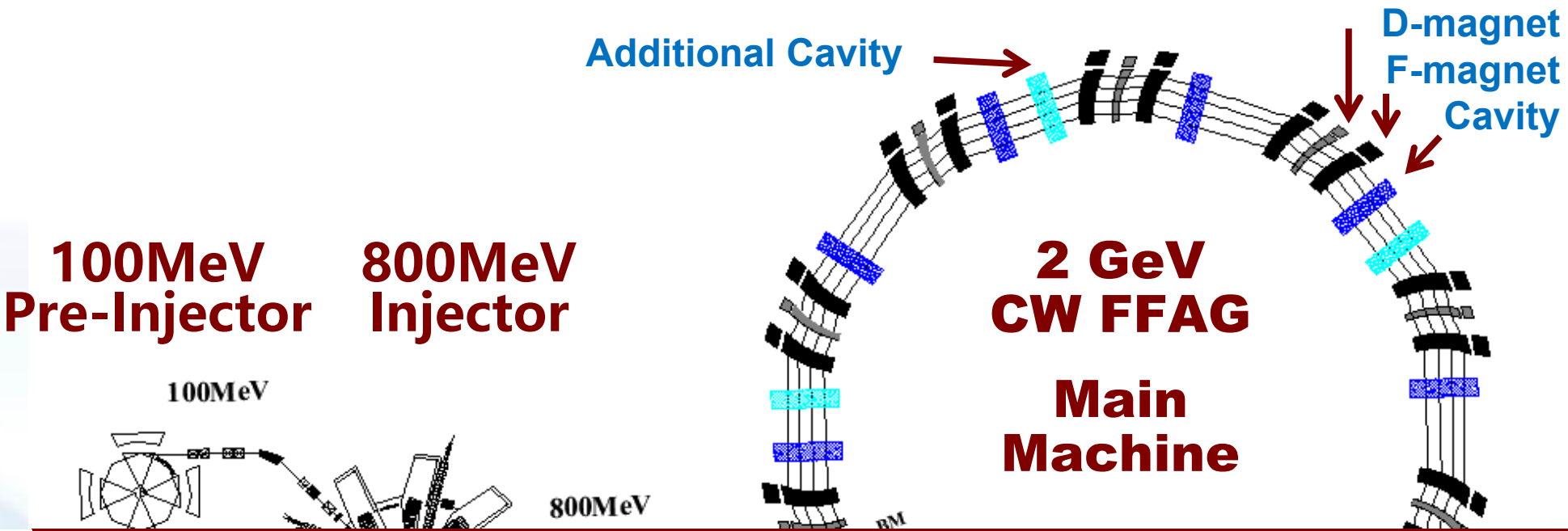

03

Five additional cavities can be added if needed, and hence increase the **turn separation to 15 mm**.

02

In the 2GeV machine, the **turn separation from 10MeV energy gain is about 10 mm**.

01

9.4 meters straight drift good for the beam injection and extraction

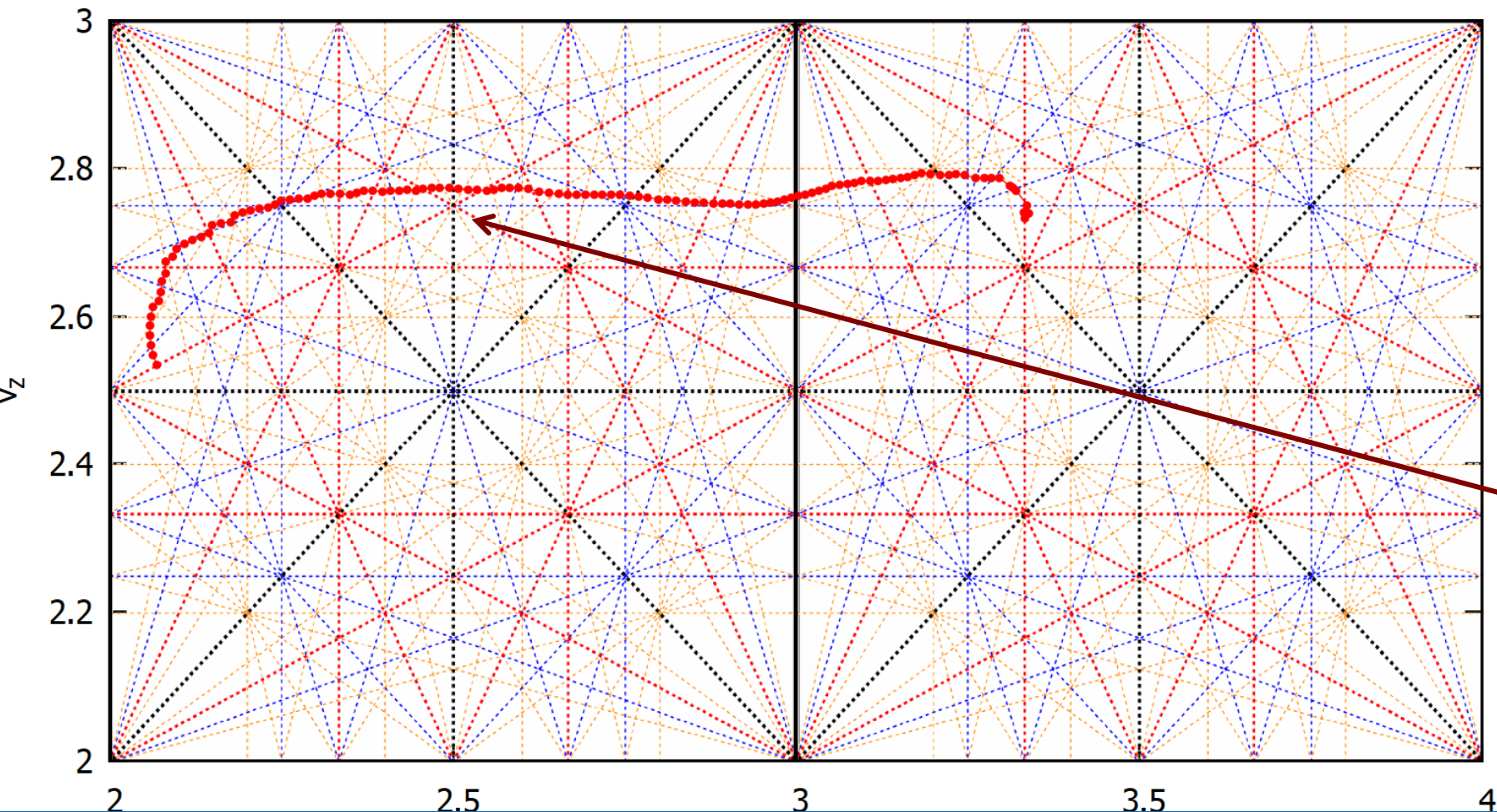

Resonance
 $\nu_r = 5/2 = 2.5$
Main Cavities: 10
Additional Cavities: 5

- 10 single gap accelerating cavities are arranged strictly in 10-fold symmetry.
- **In case the energy gain per turn of 10 MeV is not enough** for the extraction in the following detail design. **Five additional cavities** can be installed in five of the ten 9.5 m long straight drift sections, to increase the energy gain per turn from 10 MeV to 15 MeV.

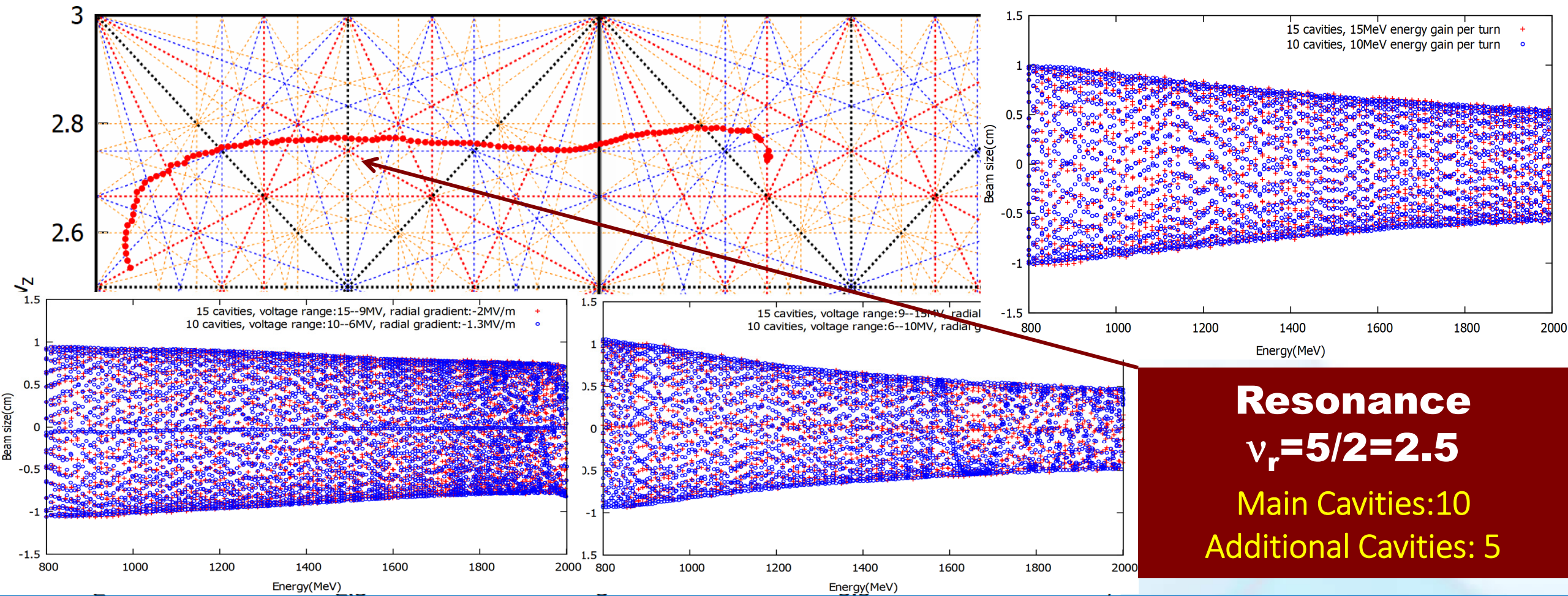

- 10 single gap accelerating cavities are arranged strictly in 10-fold symmetry.
- **In case the energy gain per turn of 10 MeV is not enough** for the extraction in the following detail design. **Five additional cavities** can be installed in five of the ten 9.5 m long straight drift sections, to increase the energy gain per turn from 10 MeV to 15 MeV.

$$\Delta r = \Delta r_0 + \Delta x \sin(2\pi n v_r \theta + \varphi_0) + x \Delta \sin(2\pi n v_r \theta + \varphi_0)$$

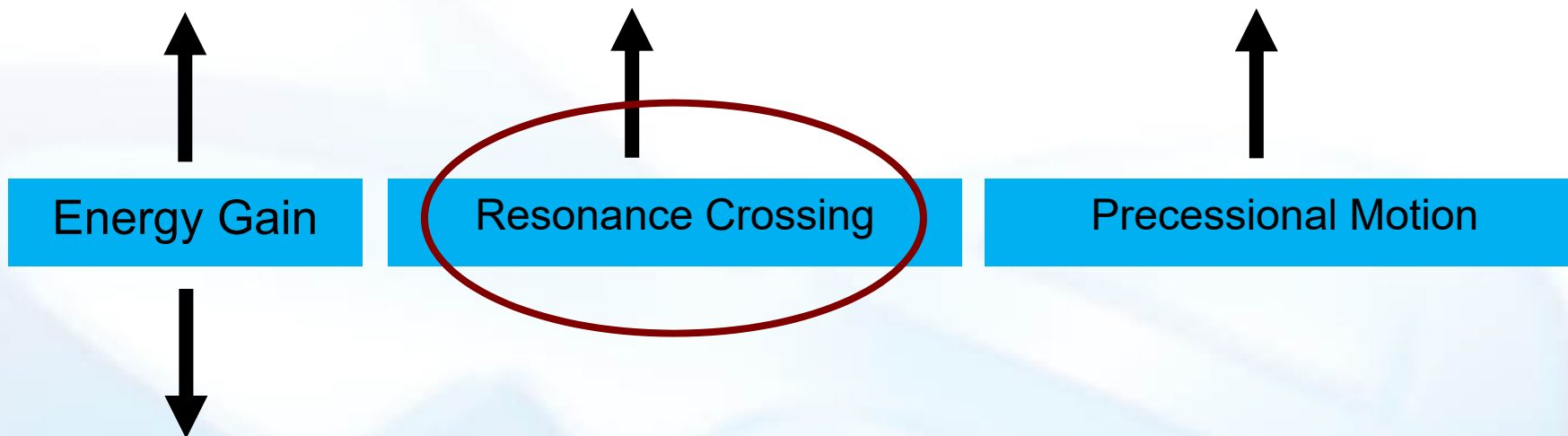

Initially, 10 Cavities is adopted to obtain **10 MeV** energy gain and the turn separation is about **10mm**.



Fundamental consideration for the **extraction**, emphasizing on the turn separation

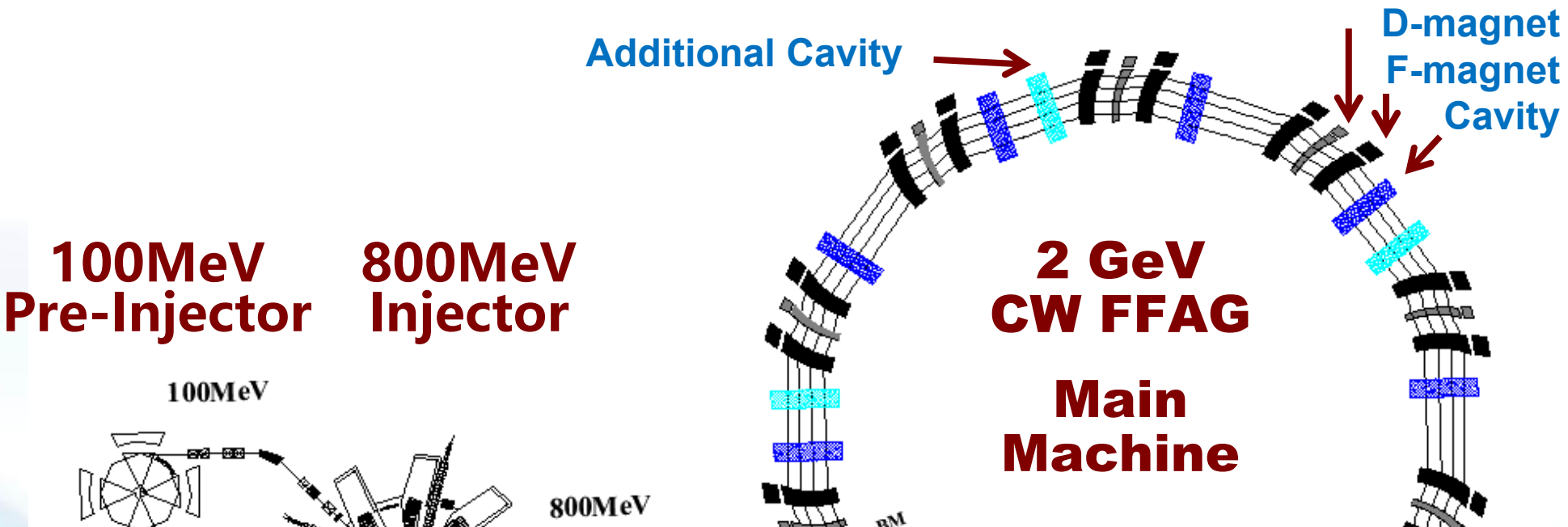

03

Five additional cavities can be added if needed, and hence increase the **turn separation to 15 mm**.

02

In the 2GeV machine, the **turn separation from 10MeV energy gain is about 10 mm**.

01

9.4 meters straight drift good for the beam injection and extraction

Fundamental consideration for the extraction,

100MeV Pre-Injector

800MeV Injector

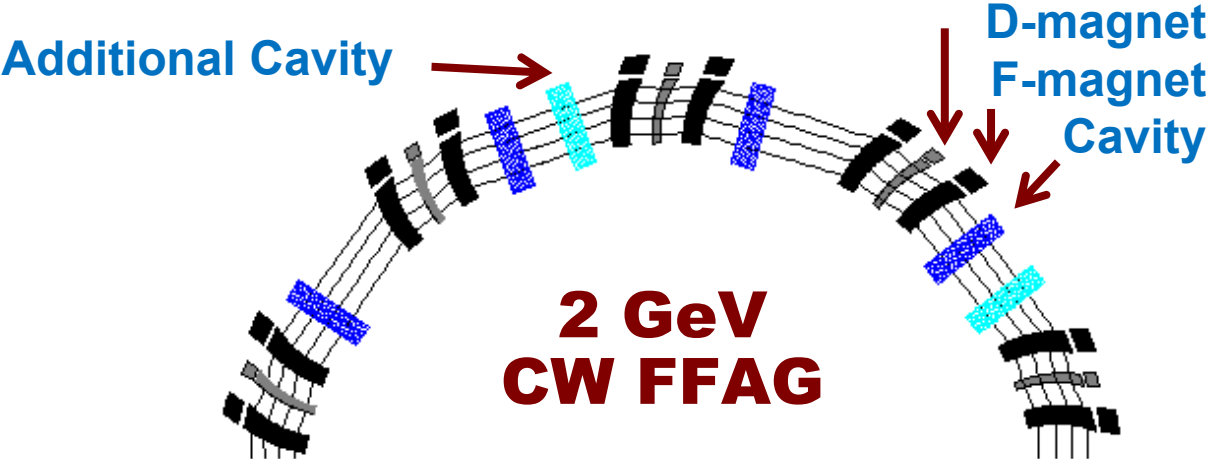

04

Resonance Crossing

03

Five additional cavities can be added if needed, and hence increase the turn separation to 15 mm.

02

In the 2GeV machine, the turn separation from 10MeV energy gain is about 10 mm.

01

9.4 meters straight drift good for the beam injection and extraction

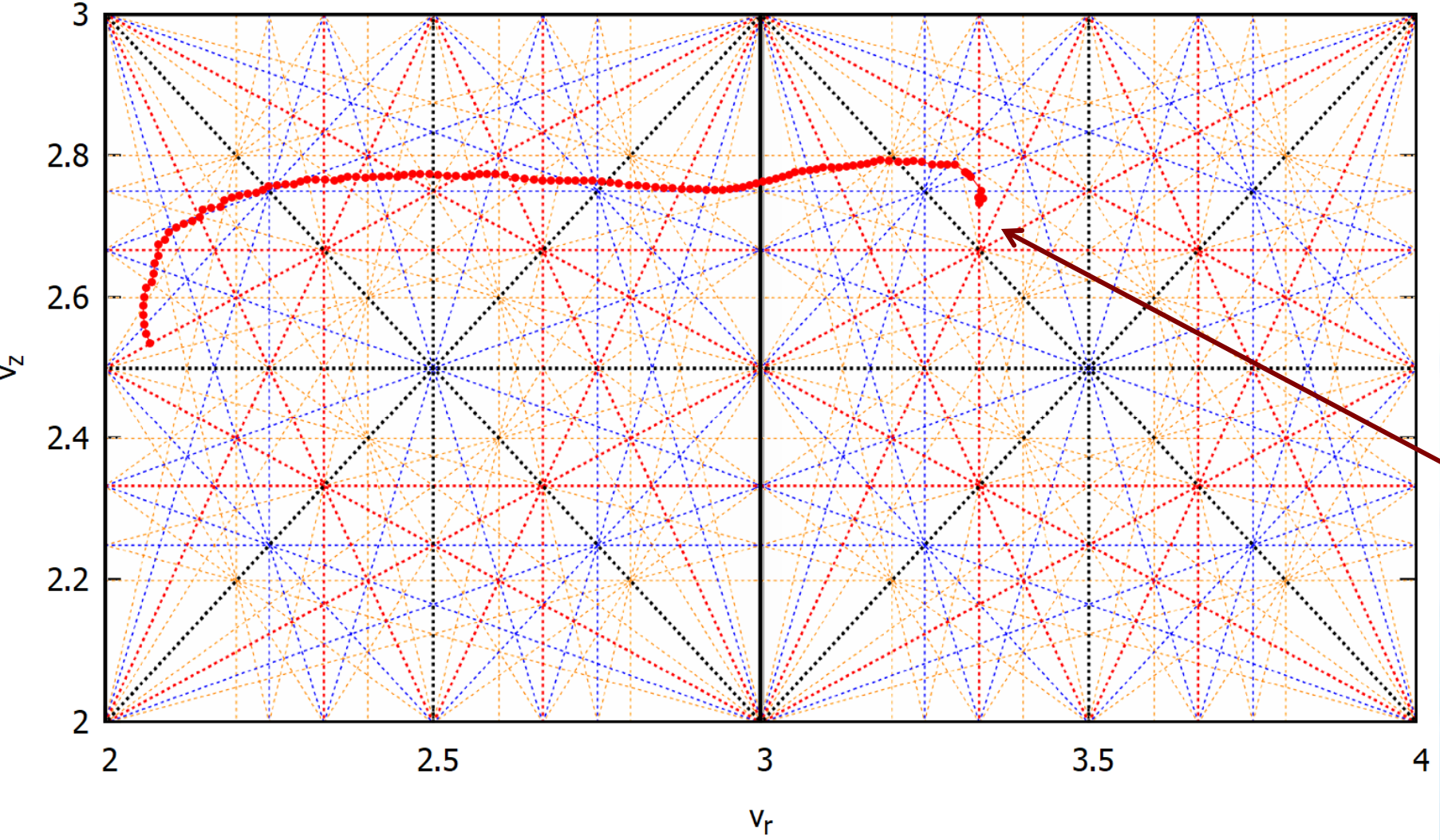

Resonance
 $3 \cdot v_r = 10$
By 10th harmonics



2 GeV CW FFAG

- the beam keeps stay near the $3\nu_r=10$ resonance for a long time, expecting to get larger turn separation.

Resonance
 $3 \cdot \nu_r = 10$
By 10th harmonics

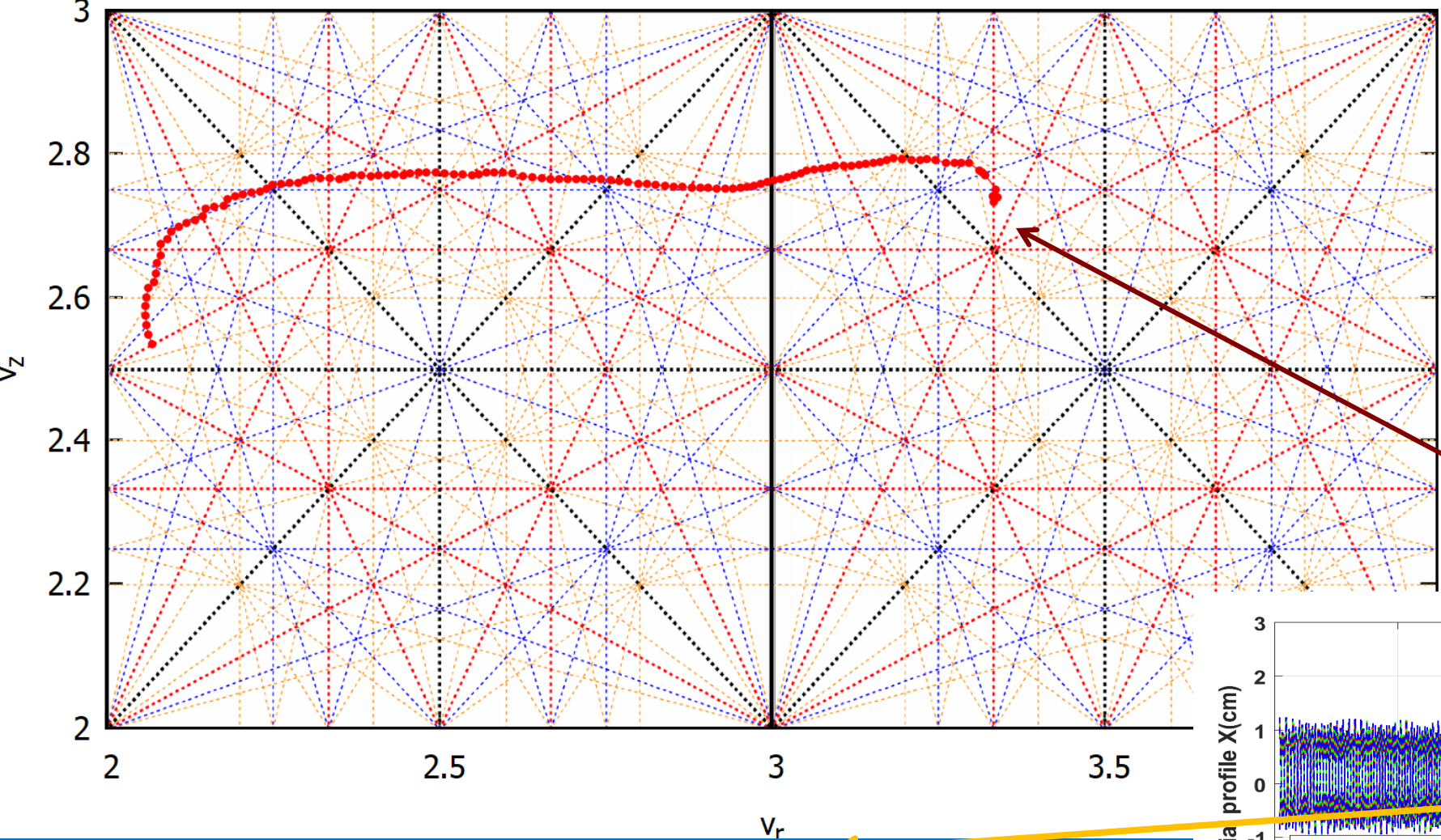

This resonance bring little oscillation growth in radial direction, maybe due to the high order, may not helpful to increase the turn separation.

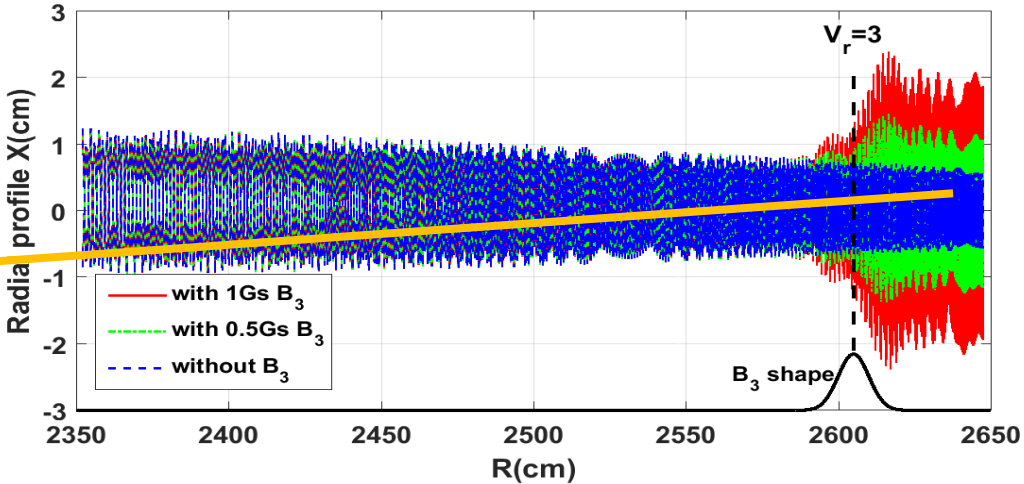

$$\Delta r = \Delta r_0 + \Delta x \sin(2\pi n v_r \theta + \varphi_0) + x \Delta \sin(2\pi n v_r \theta + \varphi_0)$$

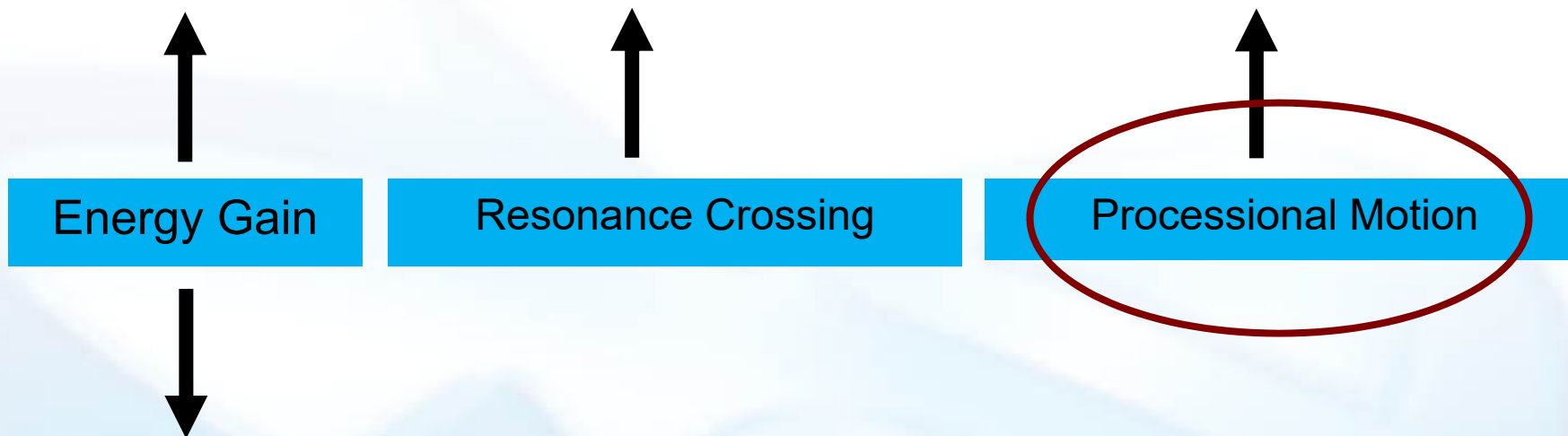

Initially, 10 Cavities is adopted to obtain **10 MeV** energy gain and the turn separation is about **10mm**.



$$\Delta r = \Delta r_0 + \Delta x \sin(2\pi n v_r \theta + \phi_0) + x \Delta \sin(2\pi n v_r \theta + \phi_0)$$

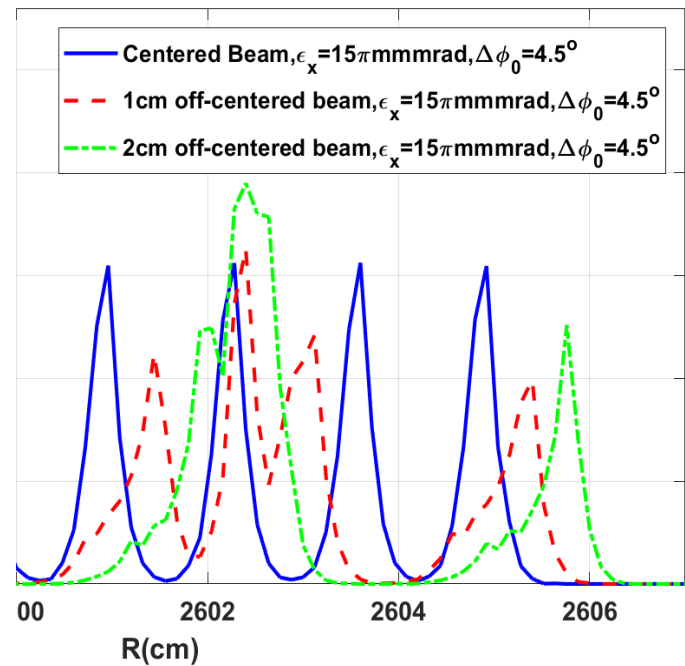
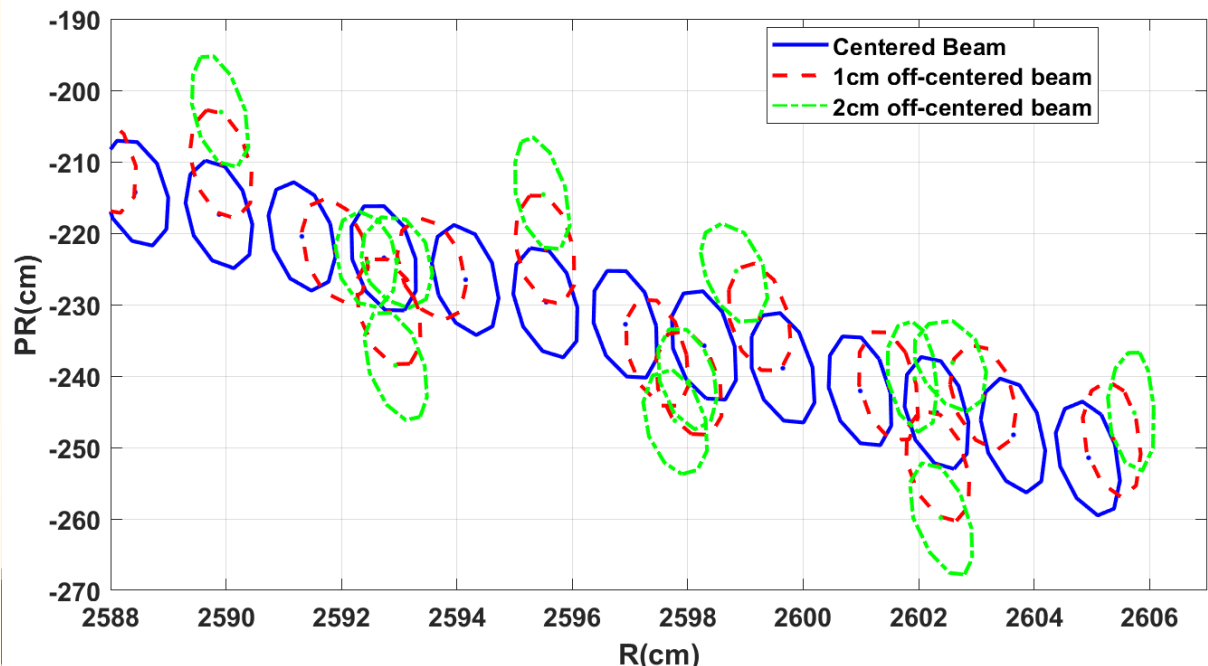
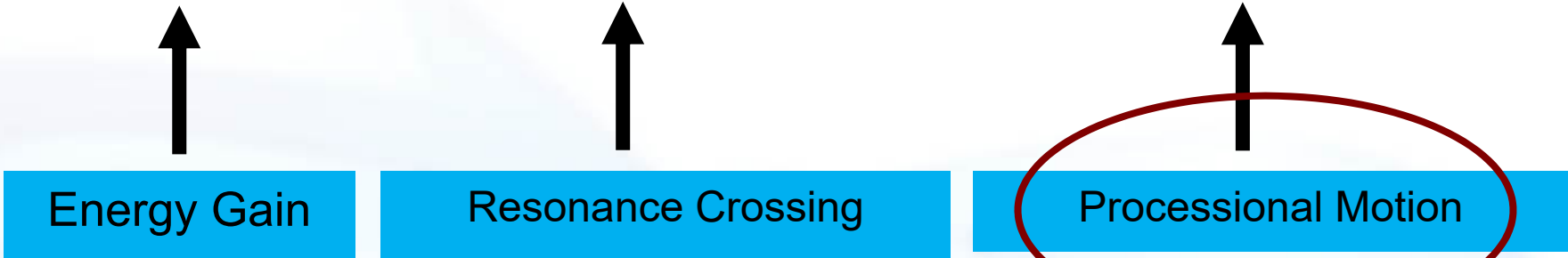

Precessional motion seems to work. 1cm off center injection
10 mm => 22 mm

Fundamental consideration

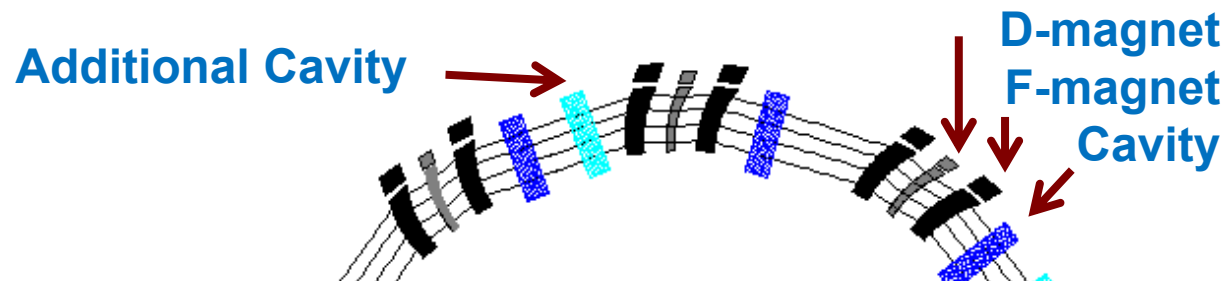

05

Precession seems to work. **10 mm off center injection** increase the turn separation from **10 mm to 22 mm**

04

Resonance Crossing

03

Five additional cavities can be added if needed, and hence increase the **turn separation to 15 mm.**

02

In the 2GeV machine, the **turn separation** from **10MeV** energy gain is about **10 mm.**

01

9.4 meters straight drift good for the beam injection and extraction

Beam Intensity Estimation

From the PSI's experience, the scaling law shows

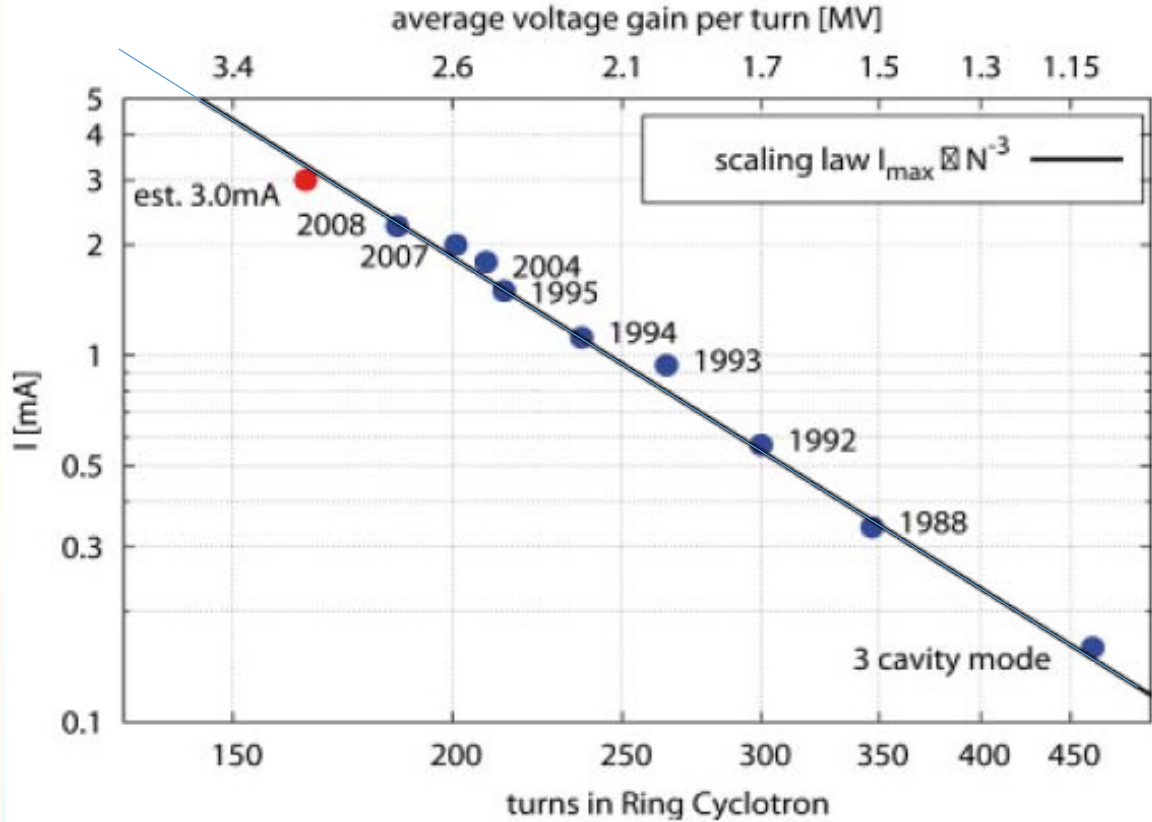

Beam Intensity Estimation
 From the PSI's experience, the scaling law shows

Tune Shift Estimation
 By the space charge of 3mA and 6mA cw beam

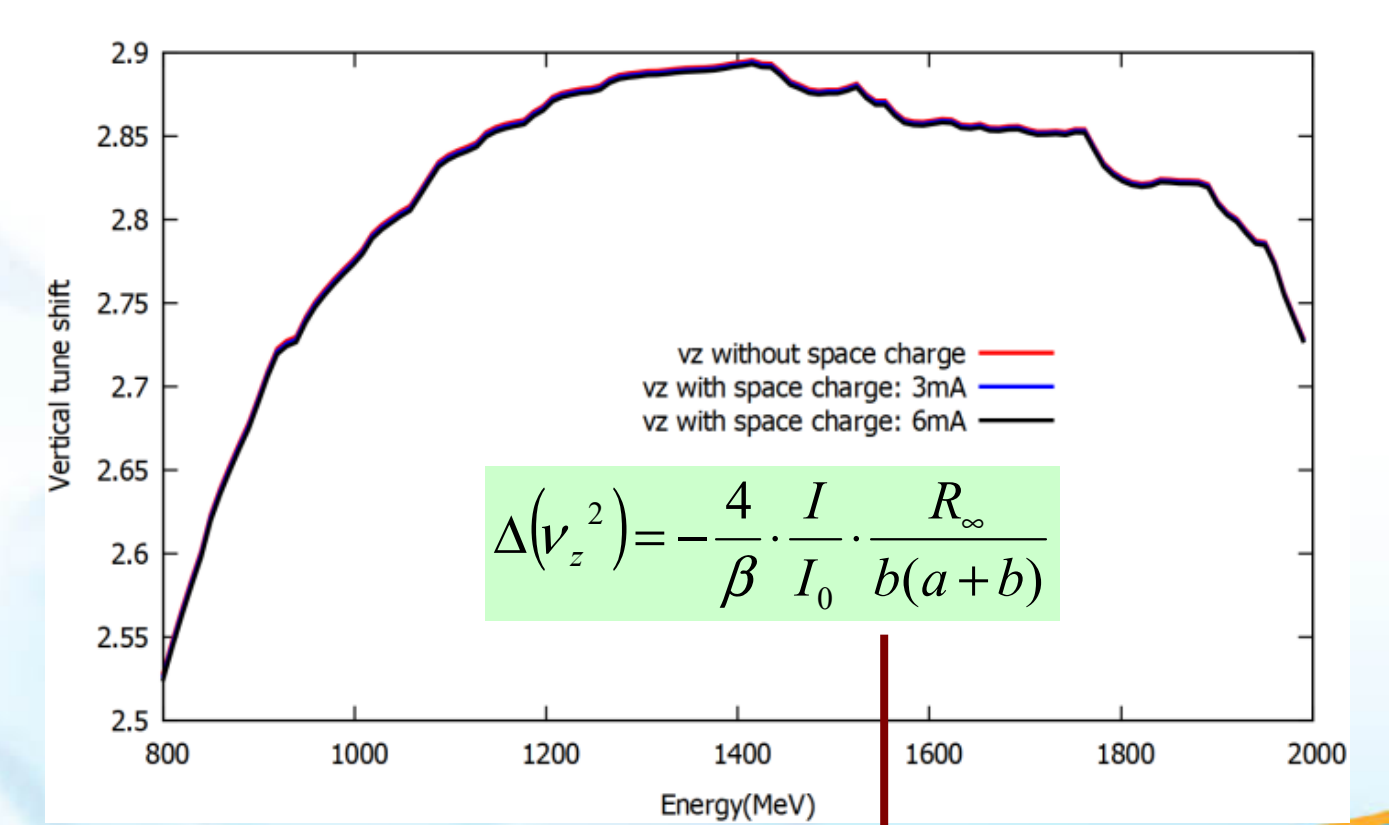
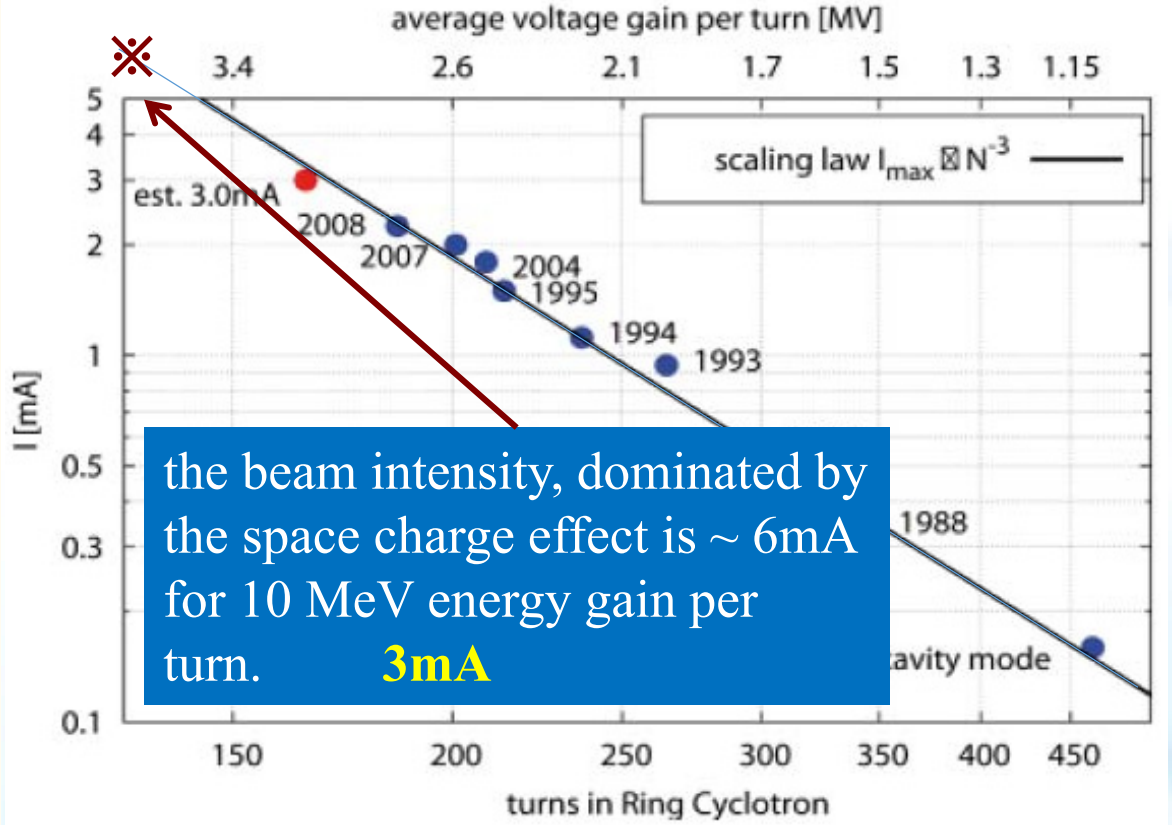

Magnet
Design and
R & D for
1:4
HTS
D-magnet

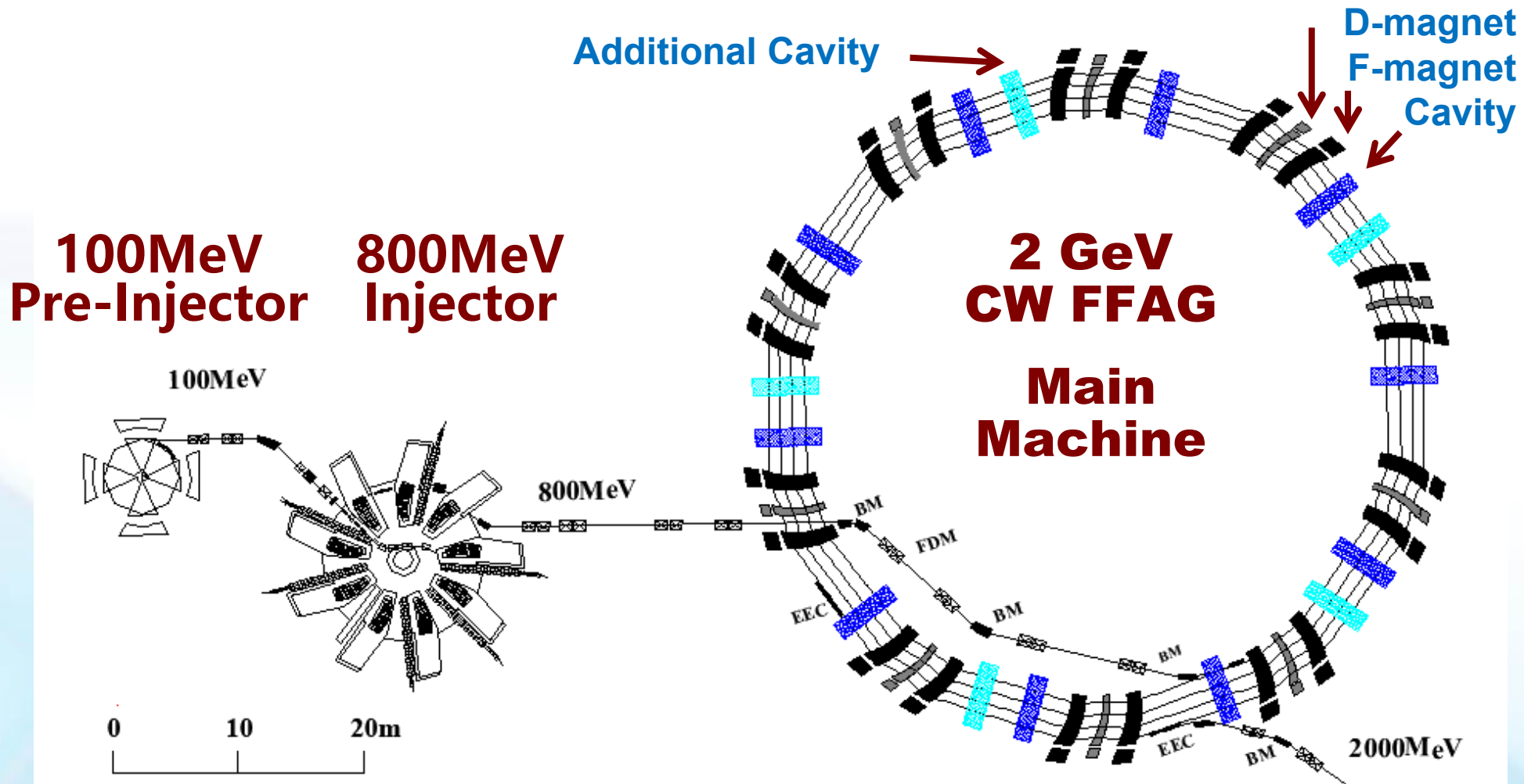

Goal: 2 GeV, 3 mA, 6 MW CW Proton Beam

2 GeV CW FFAG

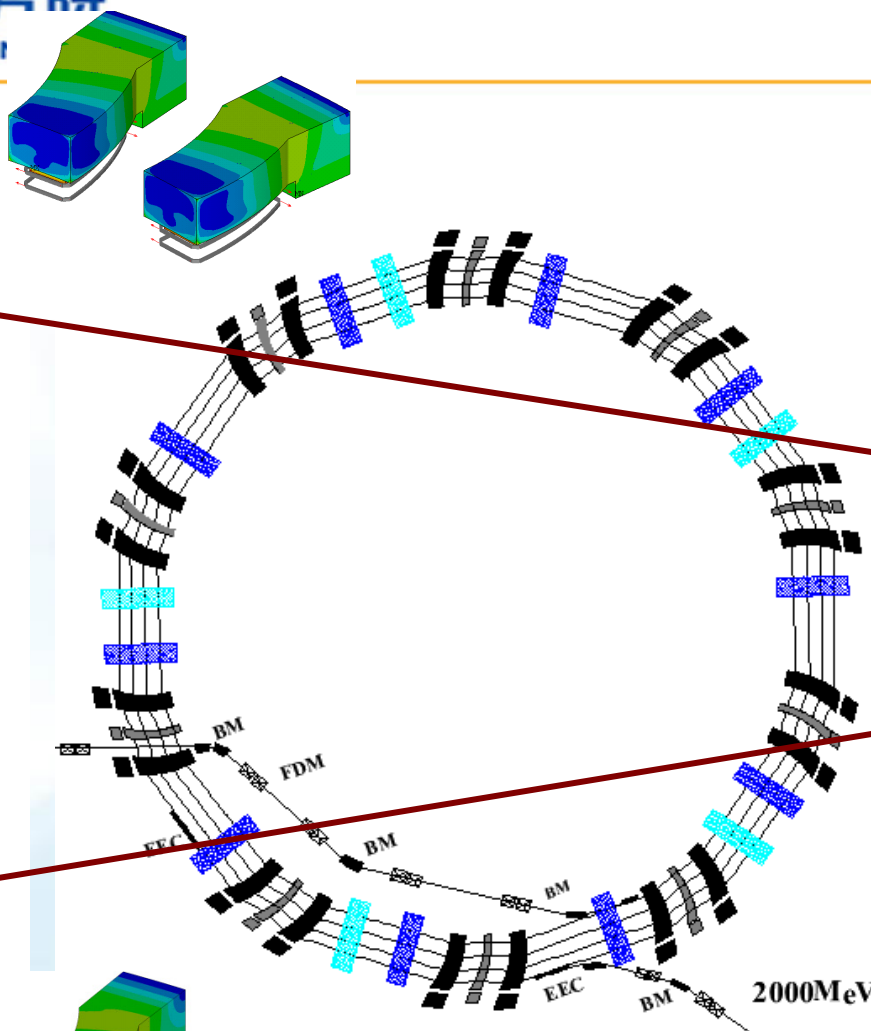
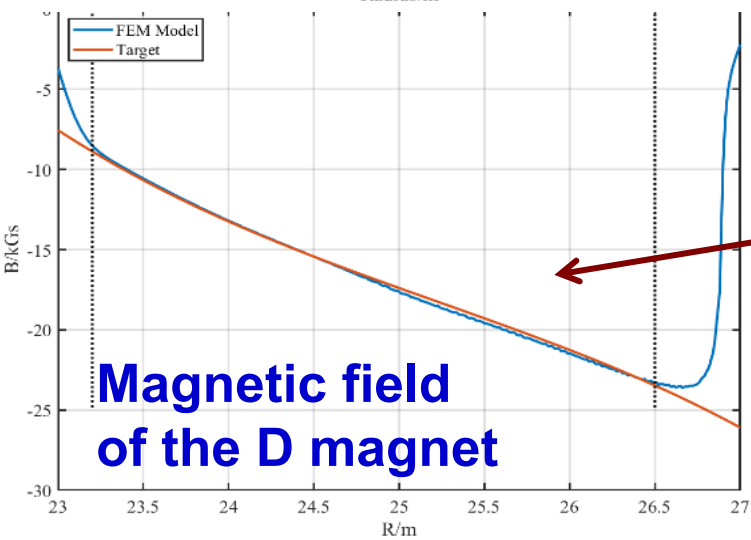
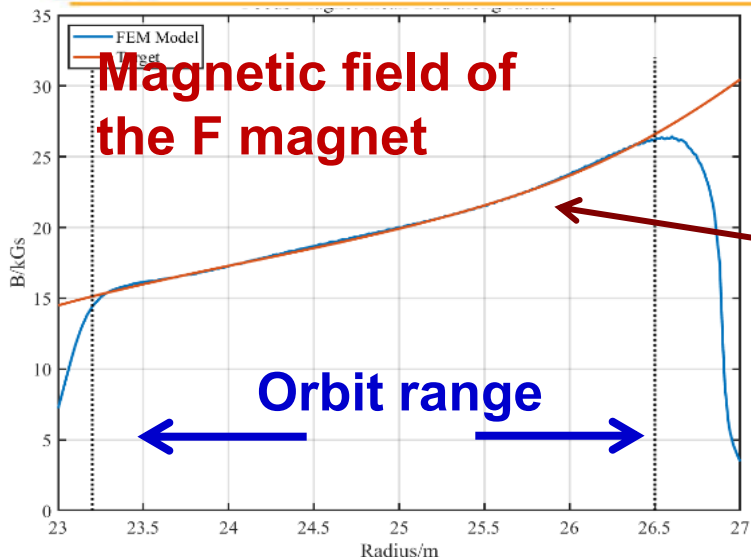

$$B_f = 0.4221 \cdot (r - 23.5)^3 - 1.7247 \cdot (r - 23.5)^2 + 4.7565 \cdot (r - 23.5) + 14.8348$$

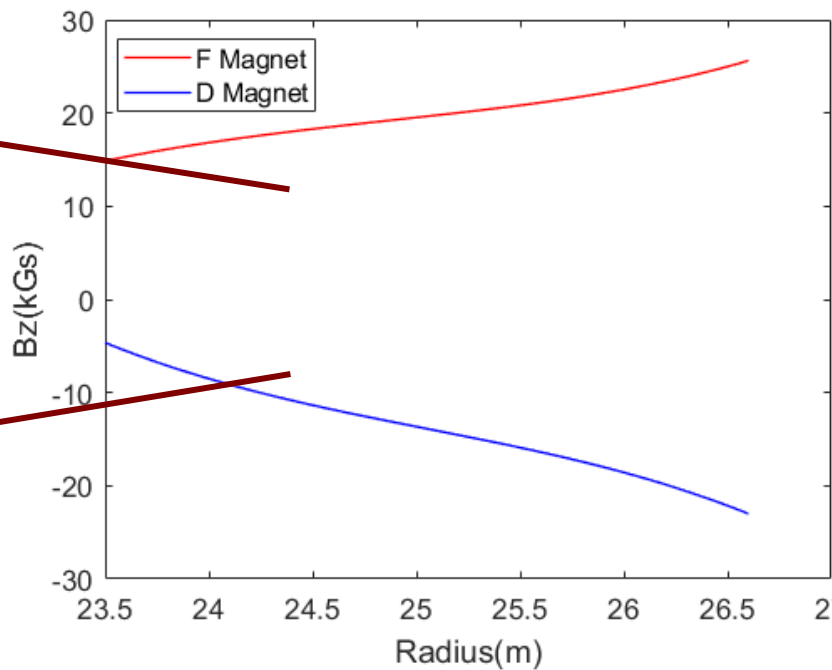

$$B_d = -0.6386 \cdot (r - 23.5)^3 + 2.9921 \cdot (r - 23.5)^2 - 9.0592 \cdot (r - 23.5) - 4.6466$$

After obtaining the analytical magnetic field and the basic geometry of the magnets, e.g. the spiral angle, then the magnet design is initiated, to match the field distribution between the FEM and the analytical model

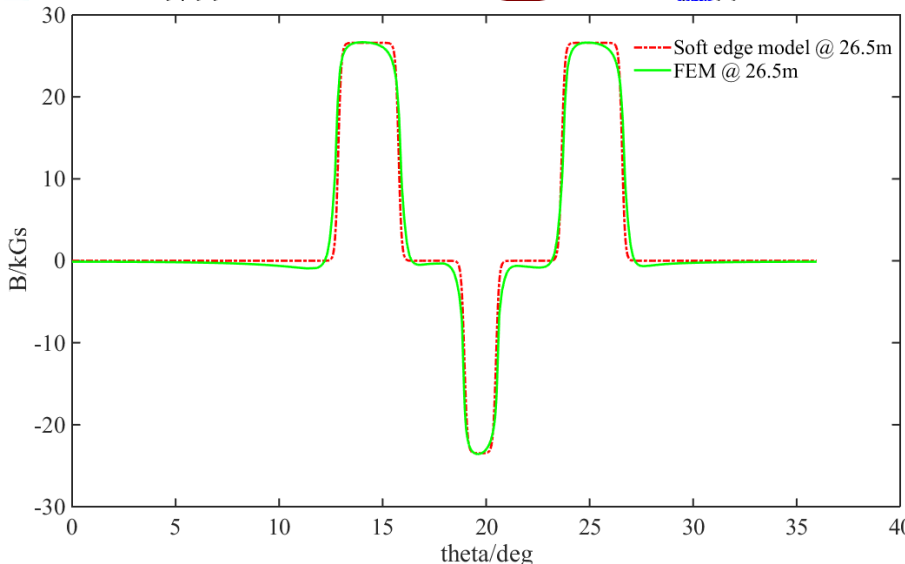
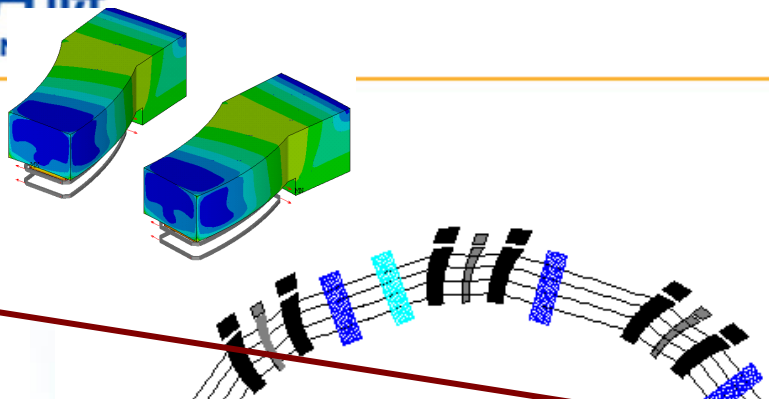
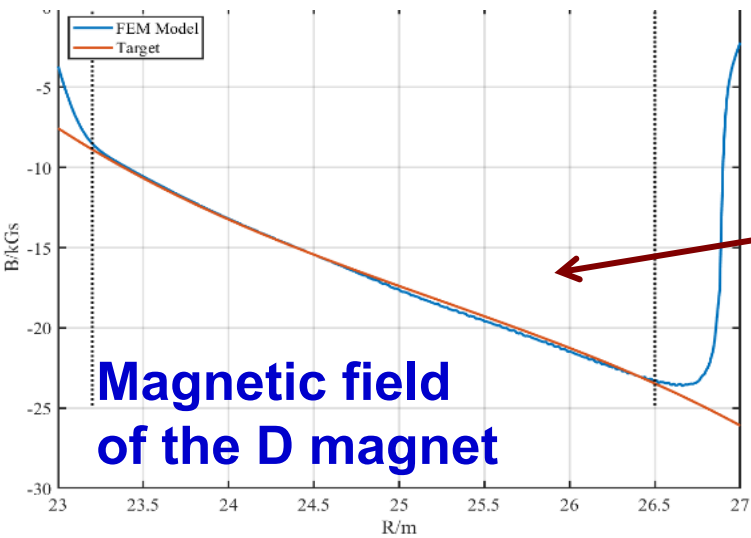
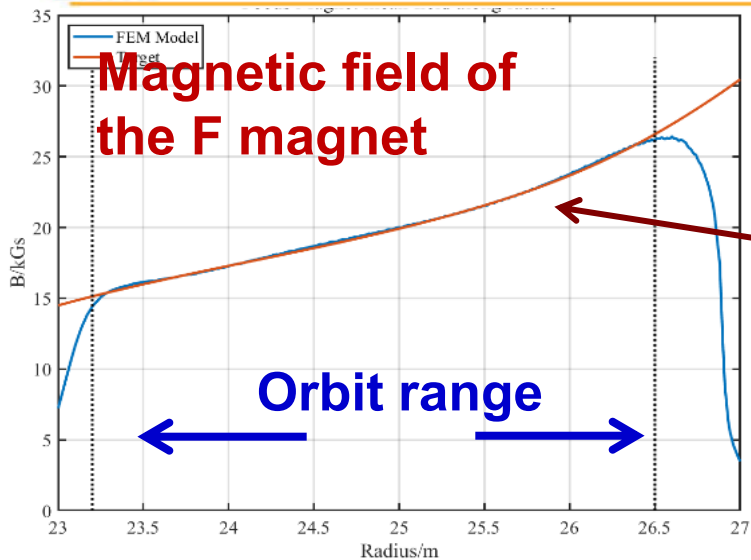

$$B_f = 0.4221 \cdot (r - 23.5)^3 - 1.7247 \cdot (r - 23.5)^2 + 4.7565 \cdot (r - 23.5) + 14.8348$$

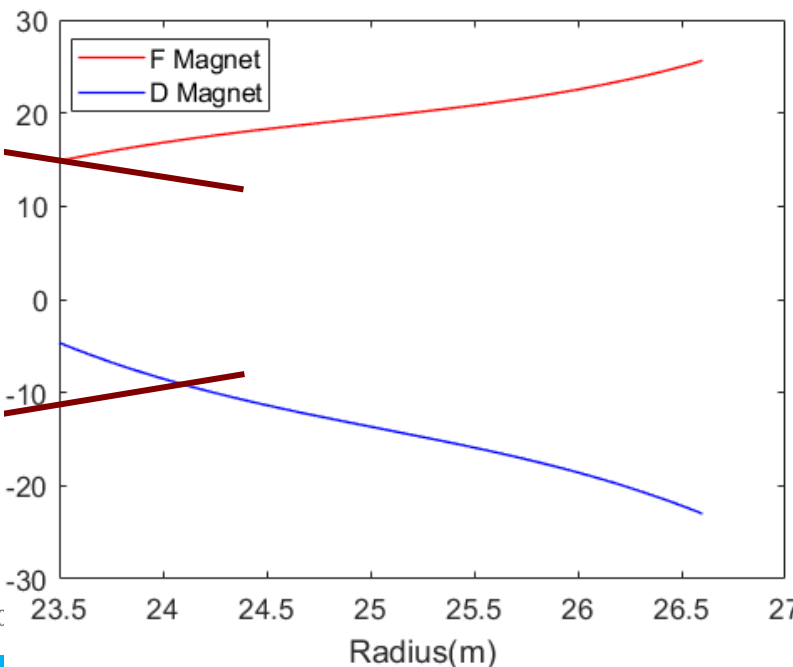

$$B_d = -0.6386 \cdot (r - 23.5)^3 + 2.9921 \cdot (r - 23.5)^2 - 9.0592 \cdot (r - 23.5) - 4.6466$$

After obtaining the analytical magnetic field and the basic geometry of the magnets, e.g. the spiral angle, then the magnet design is initiated, to match the field distribution between the FEM and the analytical model

Size and weight

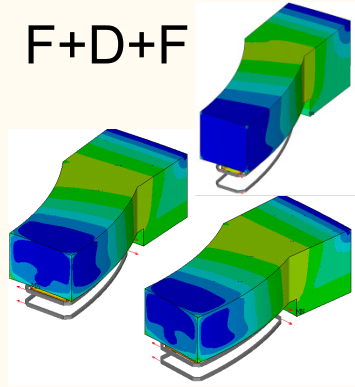

	Length/Diam. (m)	Weight (ton)	Magnetic field (T)
F Bend	~5.4	~386	1.5~2.7
D Bend	~5.4	~266	-1.0~-2.4
CYC-100	6.2	435	0.3~1.36

The weight and dimension of each F / D magnet is equivalent to the main magnet of CYCIAE-100.



100MeV:
435 ton

Magnet key tech: manufacture, mapping & shimming large range pole profile

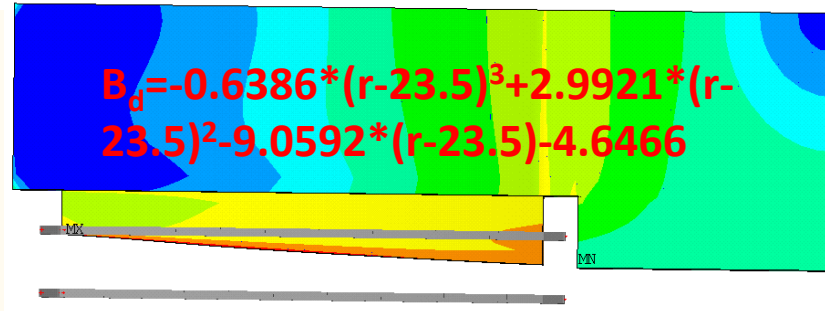
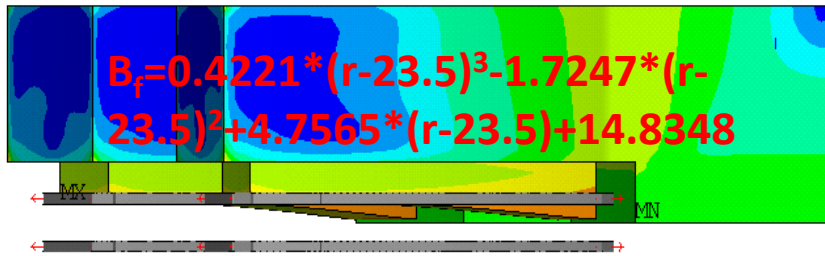

Curved pole profile of CW FFAG

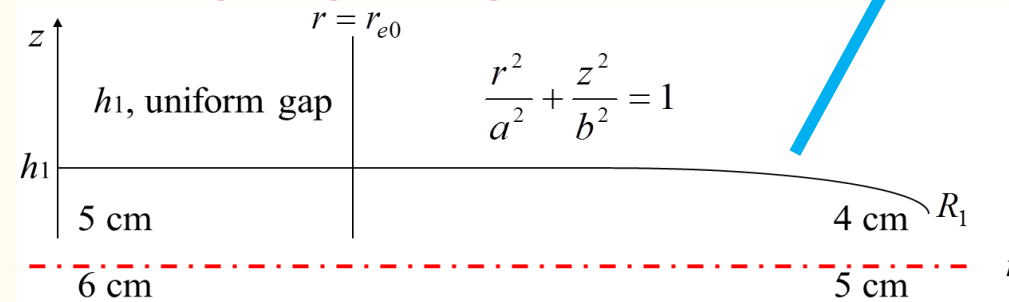

Elliptical pole profile of CYCIAE-100 magnet

The large field varying along radius requires a large range of pole gap varying. Considering successful use of elliptical gap in 100 MeV cyclotron, the 3rd order B_f , B_d , $n=3$ will be used in the magnet design.

$$g_{k(k=d,f)} = a_{k,0} + \sum_{i=1}^n a_{k,i} r^i$$

The iron magnet of 2GeV FFAG could benefit a lot from the design and construction experience of the room temperature 100 MeV H⁻ cyclotron CYCIAE-100.

Why High Temperature Superconducting (HTS) coils?

Smaller size than Copper coil magnets, radiation resistant compared to LTS magnets & low power consumption.

	Room temperature coil	HTS coil	LTS coil
Radius of FFAG ring	~34m	~27 m	~18m
Radiation resistance	Yes	Yes	No
Power consumption	Very Large	Low , easier to remove heat@30K	Medium , need more cooling power to remove heat@4.2K

HTS magnet design

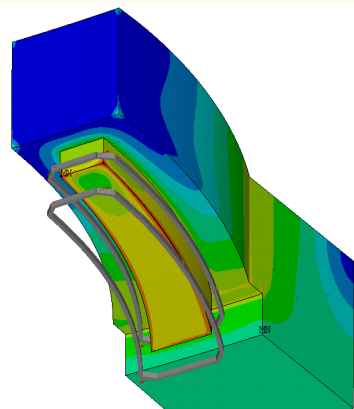

1/4 Scale HTS magnet R&D

A 1/4 scale of the D magnet with the same curvature and similar magnetic field distribution in radial direction will be built. Before that, some elementary technologies will be experimentally studied on smaller scale HTS pancake windings. Study on HTS coil winding and fixing, quench detection, protection, etc.

FRIB's Experience in similar project

B_{max}~2.6 T, compatible to FRIB^[1], using REBCO HTS wire, which has high current density, is superstable, and easy to handle^[2].

- [1] S.A. Kahn, et al. Proceedings of PAC2013, Pasadena, USA
- [2] J. V. Nugteren, Proc. of MT-25, Amsterdam, The Netherlands, 2017.

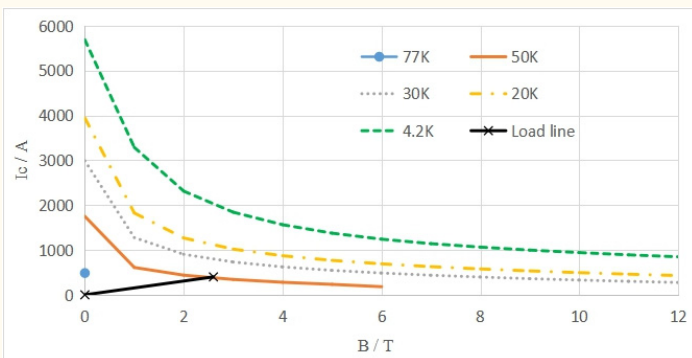

I=400 A @ 2.6 T, 30 K, ~50% of Ic, large temperature margin of ~20 K, a thermal stable design, crucial for stable operation in high power accelerators.

Low temperature Helium gas cooling design demonstrated by FRIB[3].

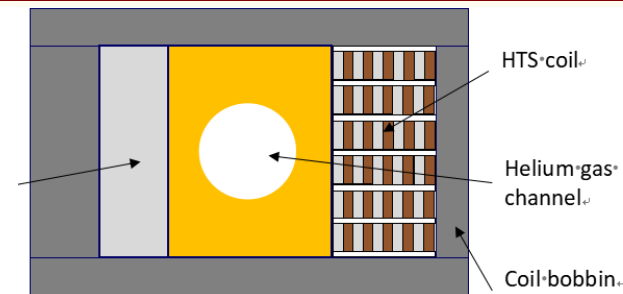

[3] R. Johnson et al. <https://science.energy.gov/>

RF System
Design and
R & D for
1:3
Cavity
manufacture

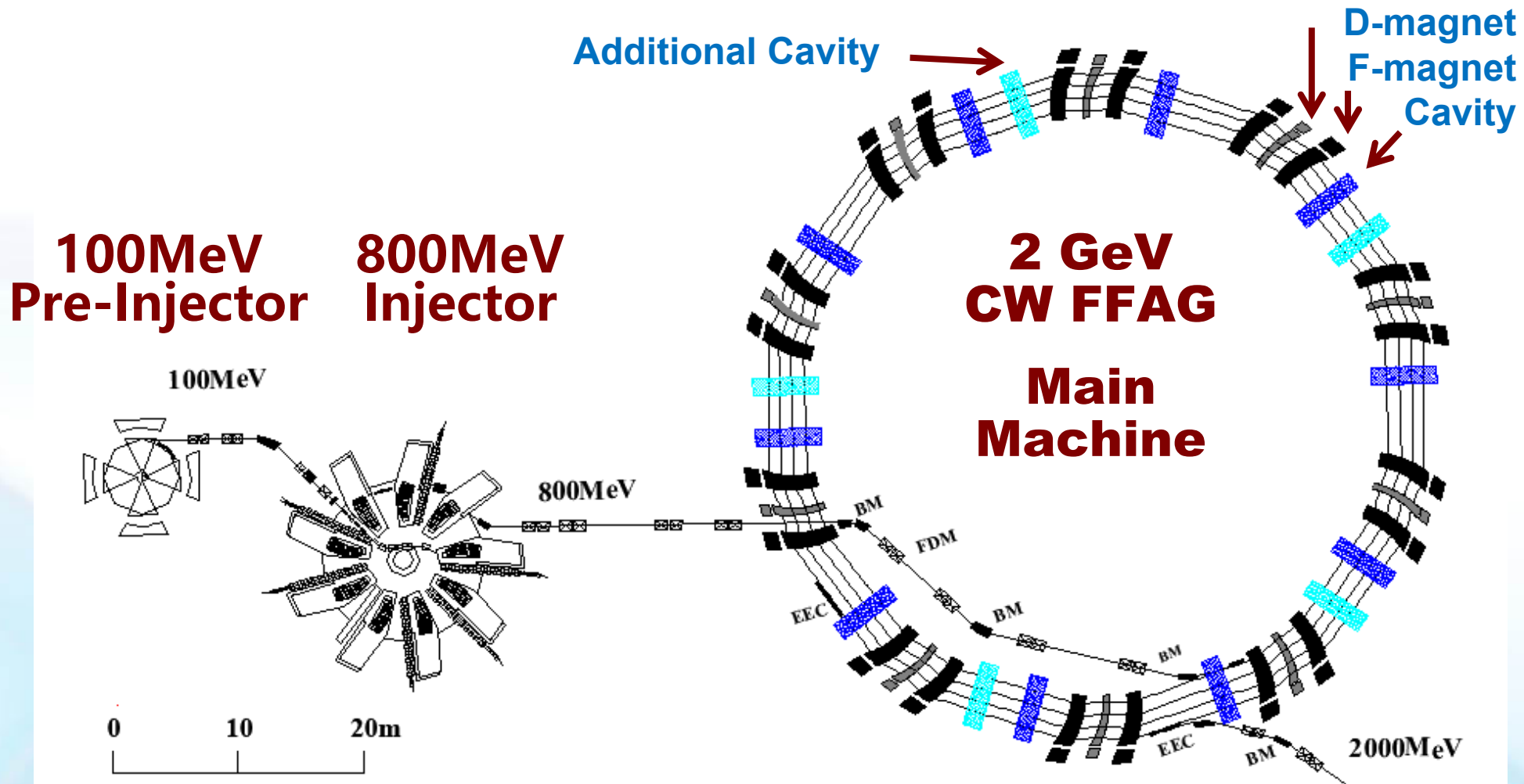

Goal: 2GeV, 3mA, 6MW CW Proton Beam

Preliminary Design of RF System for 2GeV FFAG (Phase distribution & Amplifier considerations)

The RF system includes all the hardware through which energy flows from the AC line to the RF cavities, and it is comprised of ten modules evenly spaced on the circumference of the accelerator. The RF system will start up from the self-excitation mode and then change to the drive mode for the beam acceleration under the precise control of a fully digital Low-level RF controller.

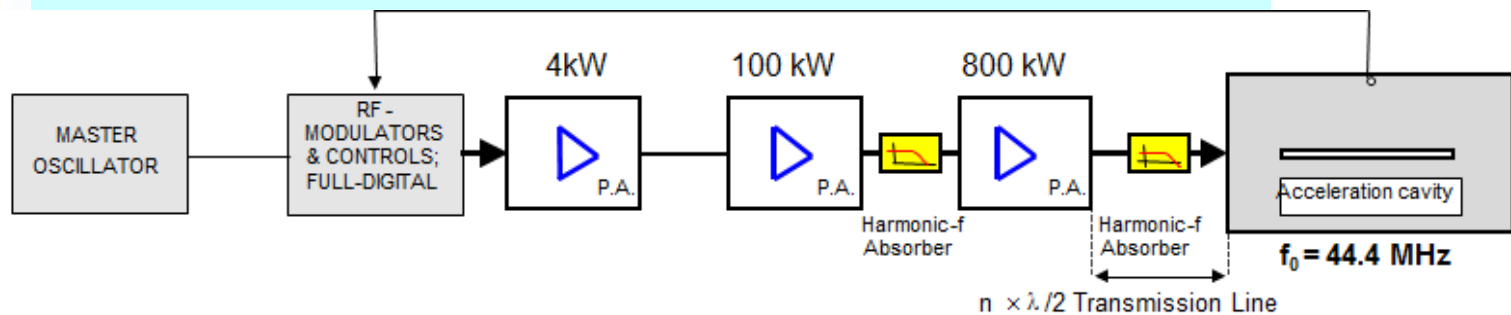
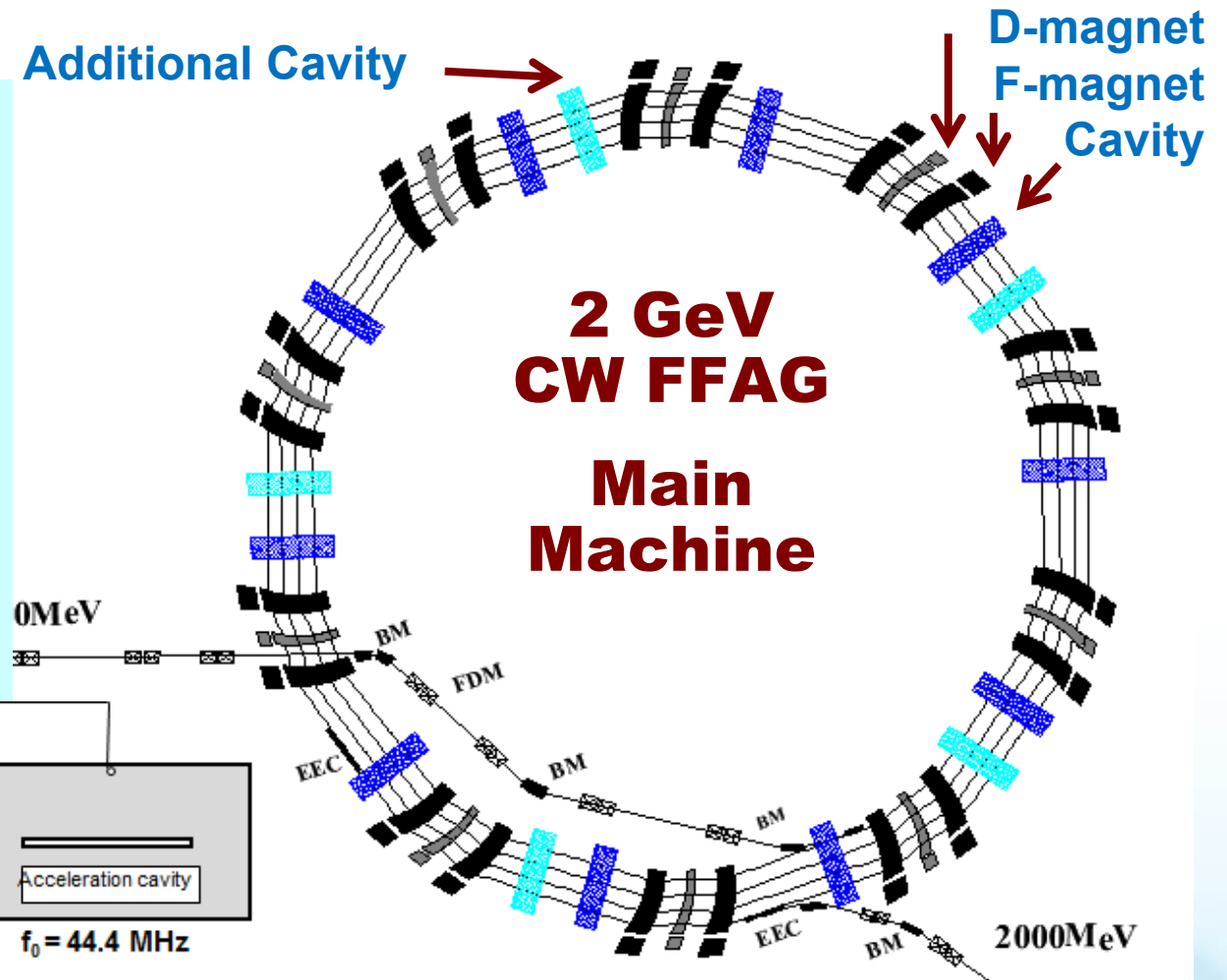

Goal: 2GeV, 3mA, 6MW CW Proton Beam

Preliminary Design of RF System for 2GeV FFAG (Cavities)

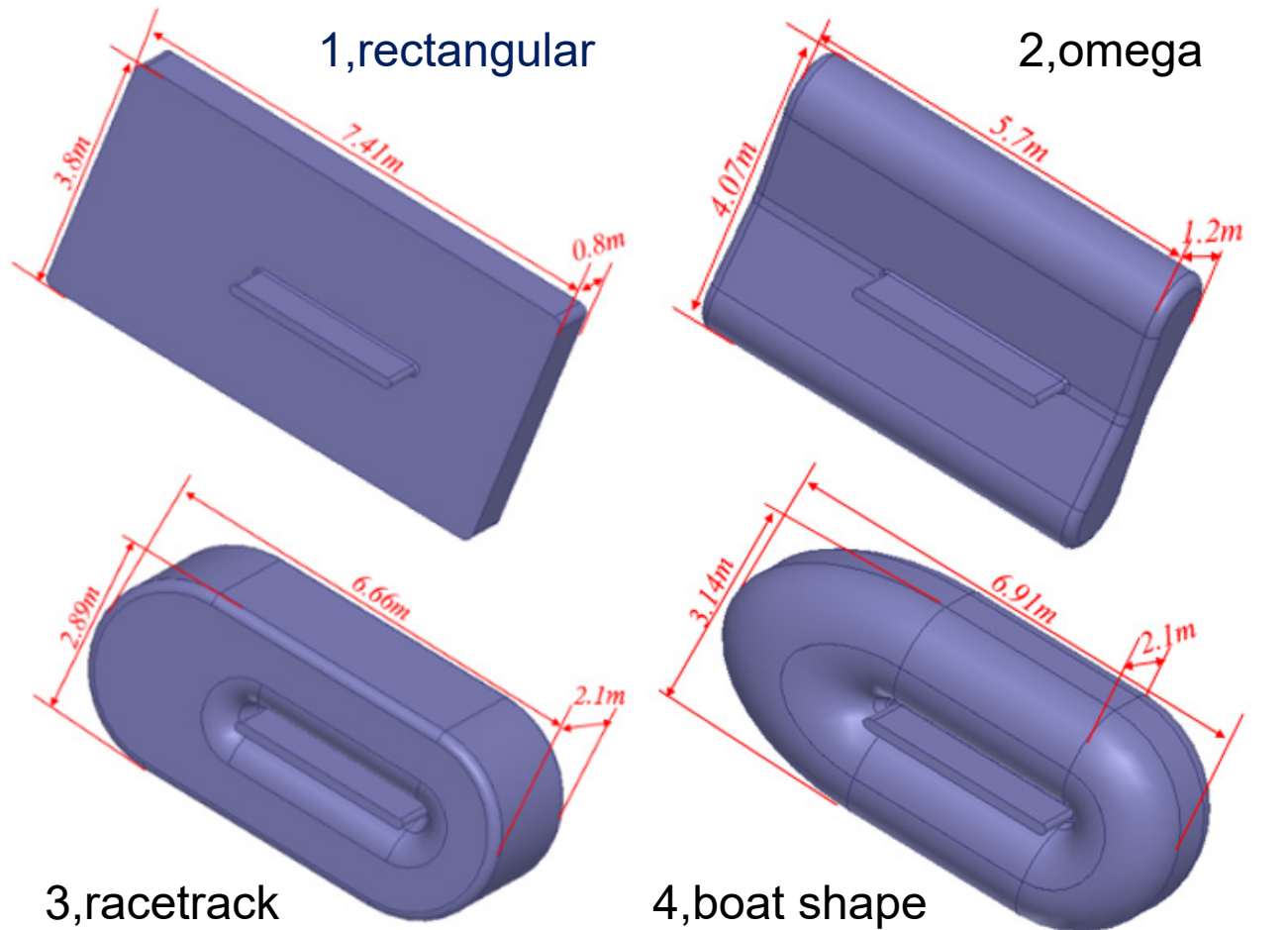

44.4 MHz waveguide-type cavities



Preliminary Design of RF System for 2GeV FFAG (Cavities)

Preliminary design of 2GeV FFAG boat-shaped cavity

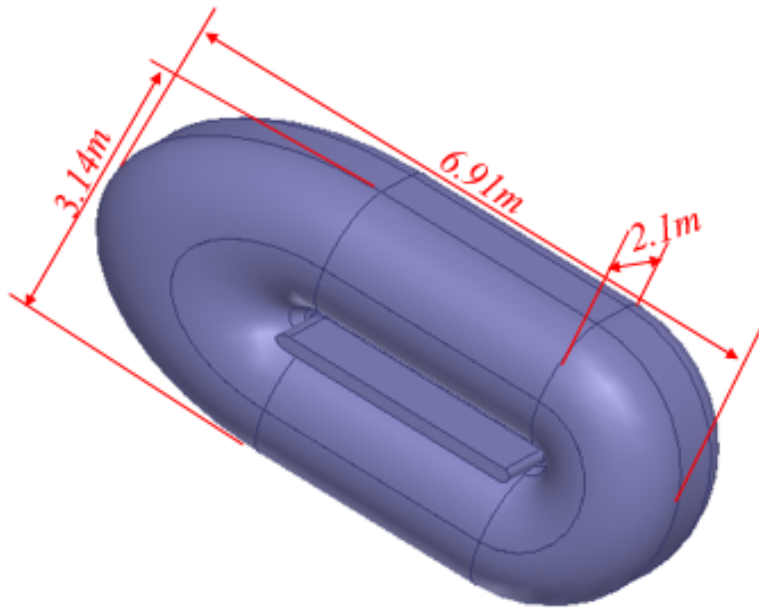

Benefit from Ring Cyclotron's RF Cavity 0.85 MV

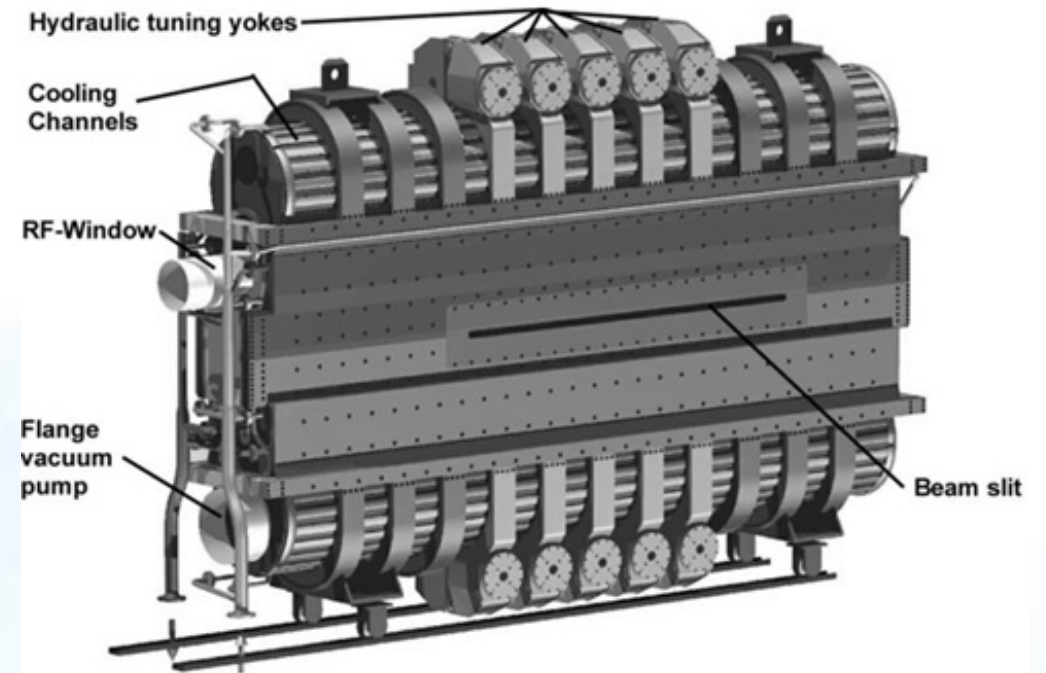

Resonance frequency	Q-value
44.40MHz	92100
RF power@ 2MV W/O Beam loading	
~200kW	

Resonance frequency		Q-value	
Calculated	Measured	Calculated	Measured
51.040 MHz	50.993 MHz	46054	45090

$L \times W \times H = 6.09m \times 2.10m \times 3.44m$
Bigger Cavity, Higher Q Value



Preliminary Design of RF System for 2GeV FFAG (Cavities)

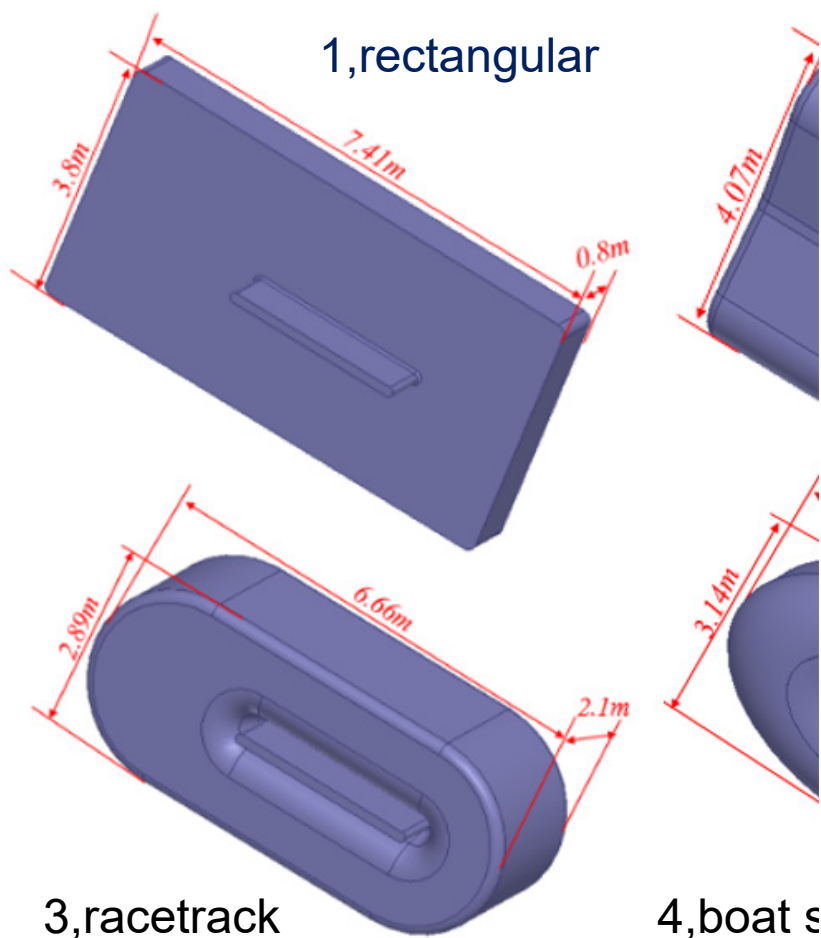

Item	Rectangular	Omega	Racetrack	Boat
Frequency(MHz)	44.42	44.41	44.38	44.40
Operating Mode	TM110	TM110	TM110	TM110
Quality Factor	58497	74673	85832	92100
Shunt Impedance(Max, MΩ)	5.38	10.08	19.29	20.14
Shunt Impedance(Min, MΩ)	2.43	2.15	10.41	10.95
Power Dissipation(kW@2MV)	743	397	207	199
Acceleration Gap Length(m)	2.8	2.8	2.8	2.85
Acceleration Gap Height(m)	0.15	0.15	0.15	0.15
Acceleration Gap Width(m)	0.8	0.8	0.8	0.8
Has it been built before?	Yes, multiple	Yes, PSI ring	Not known	Not known
Mechanical design challenge	Low	High	Medium	High
Tuning Difficulty	Low	Difficult	Medium	Difficult

44.4 MHz waveguide-ty



Preliminary Design of RF System for 2GeV FFAG (Cavities)

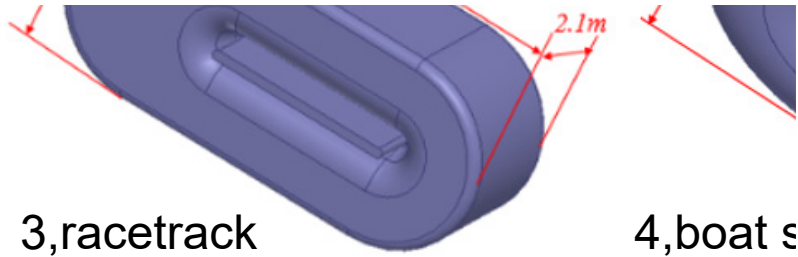
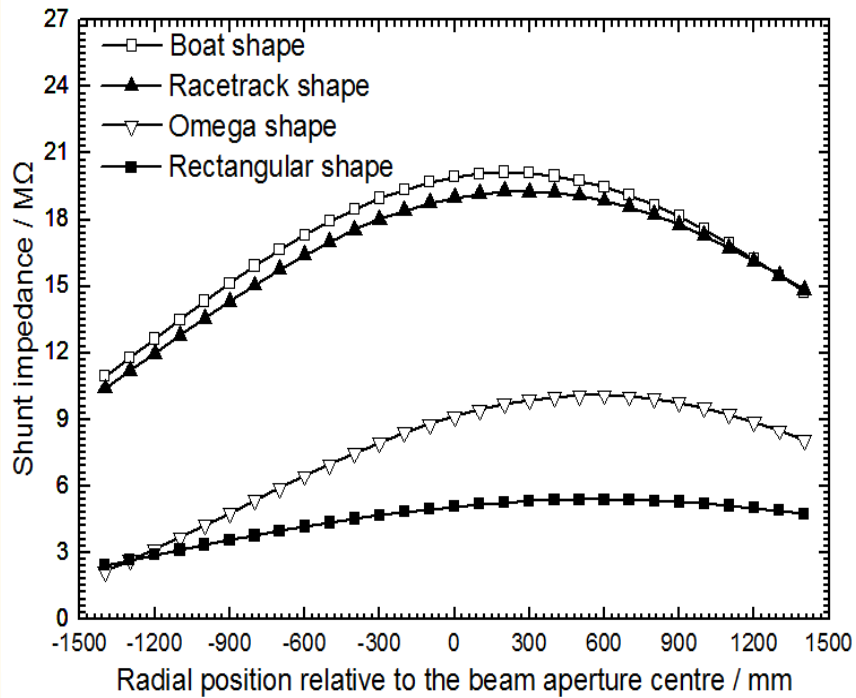

Item	Rectangular	Omega	Racetrack	Boat
Frequency(MHz)	44.42	44.41	44.38	44.40
Operating Mode	TM110	TM110	TM110	TM110
Quality Factor	58497	74673	85832	92100
Shunt Impedance(Max, MΩ)	5.38	10.08	19.29	20.14
Shunt Impedance(Min, MΩ)	2.43	2.15	10.41	10.95
Power Dissipation(kW@2MV)	743	397	207	199
Acceleration Gap Length(m)	2.8	2.8	2.8	2.85
Acceleration Gap Height(m)	0.15	0.15	0.15	0.15
Acceleration Gap Width(m)	0.8	0.8	0.8	0.8
Has it been built before?	Yes, multiple	Yes, PSI ring	Not known	Not known
Mechanical design challenge	Low	High	Medium	High
Tuning Difficulty	Low	Difficult	Medium	Difficult

44.4 MHz waveguide-ty



General Design, and R & D activities are conducted for a 2 GeV isochronous FFAG recently

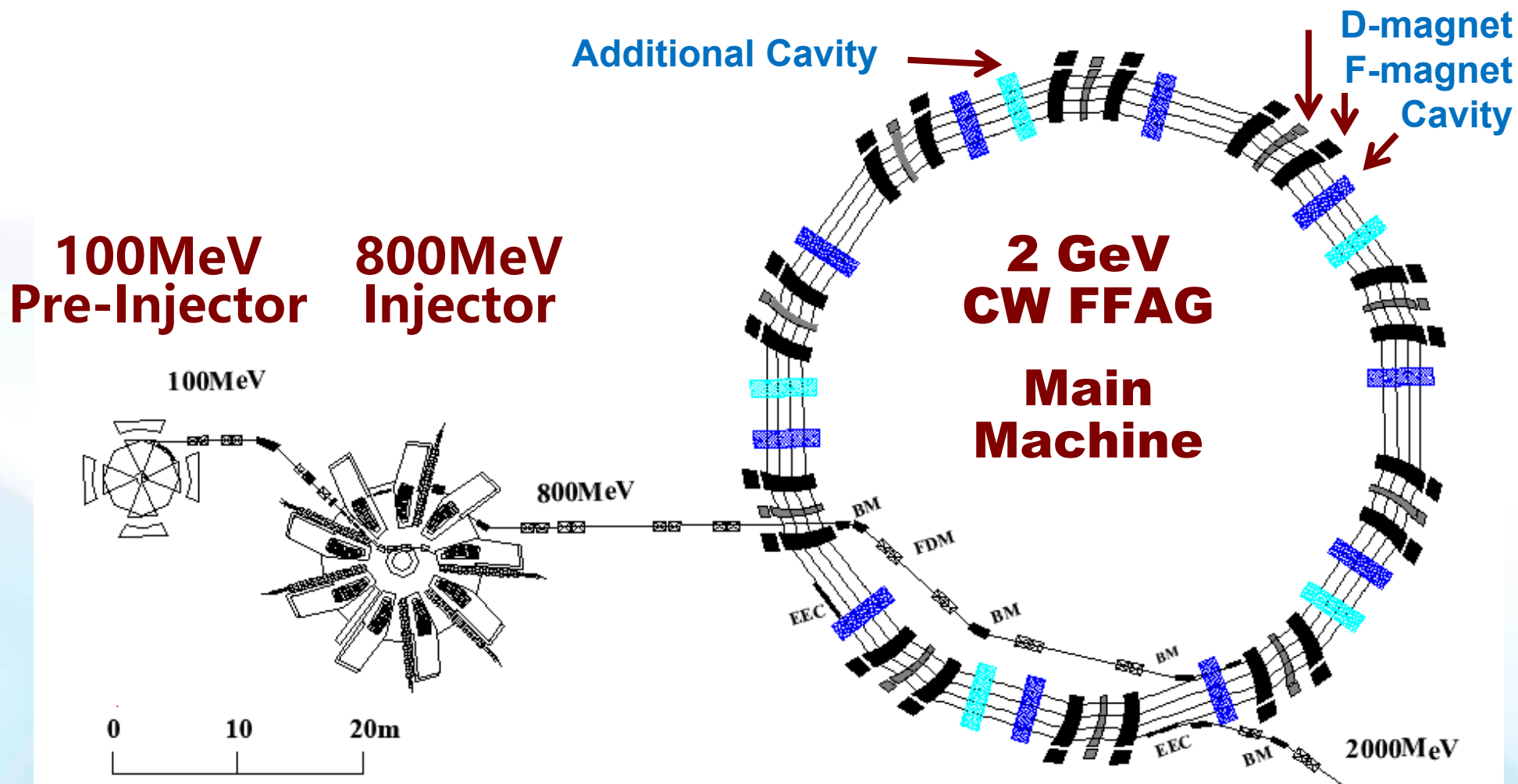

Goal: 2GeV, 3mA, 6MW CW Proton Beam

General Design, and R & D activities are conducted for a 2 GeV isochronous FFAG recently

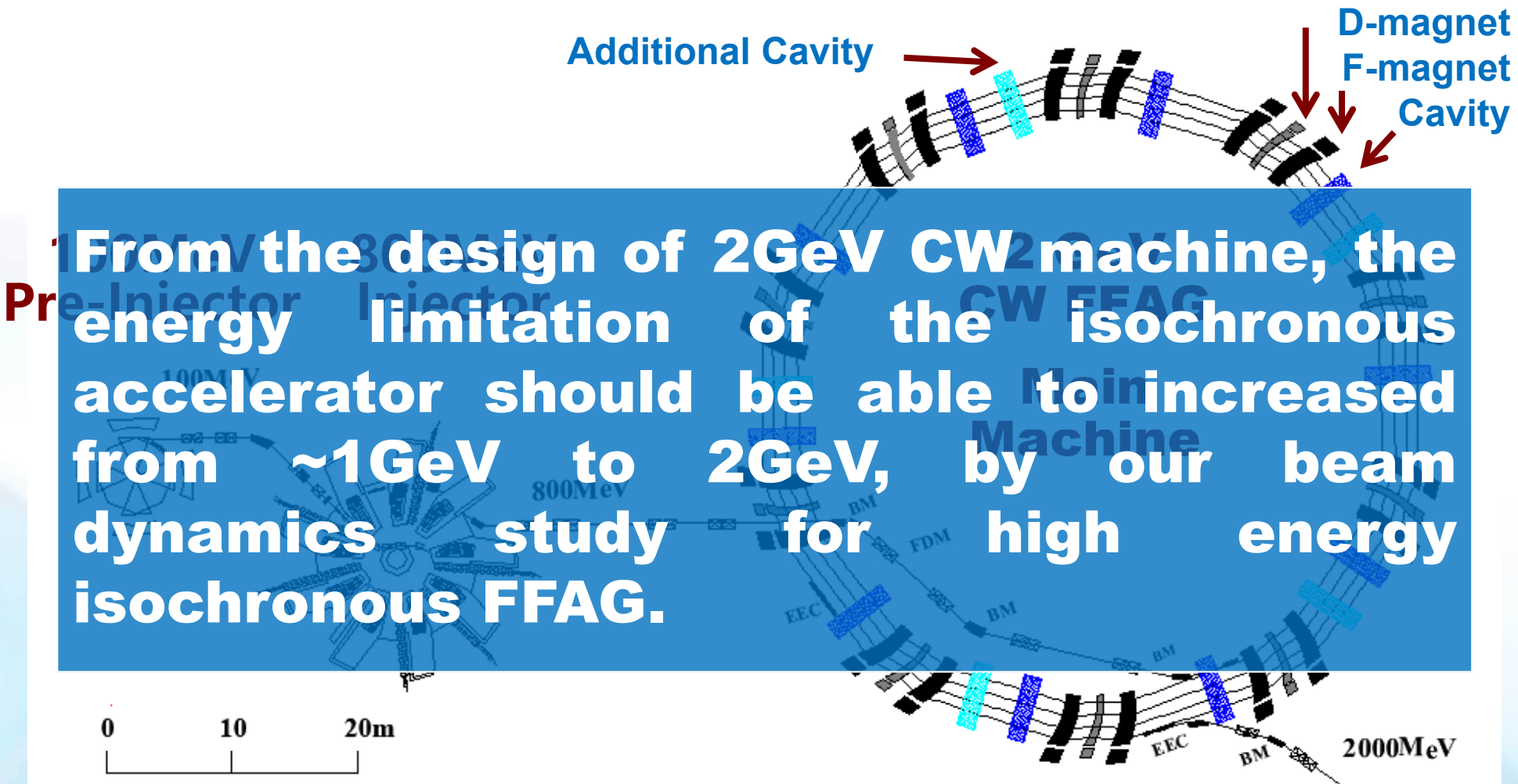

From the design of 2 GeV CW machine, the energy limitation of the isochronous accelerator should be able to increased from ~1 GeV to 2 GeV, by our beam dynamics study for high energy isochronous FFAG.

Goal: 2 GeV, 3 mA, 6 MW CW Proton Beam

ACKNOWLEDGEMENTS

- We would like to extend our cordial gratitude to experts from TRIUMF, PSI, INFN-LNS and the international cyclotron community for their long-term support,
- and the recent email discussion with Dr Calabretta and Dr Rao about the beam physics for the 2GeV machine.



THANK YOU



中國原子能科學研究院
CHINA INSTITUTE OF ATOMIC ENERGY

中核集團

一壆一器

宋朝C厅
SONG HALL C

