

Multi-beamline Operation at SACLA

Toru HARA, Takahiro INAGAKI, Kazuaki TOGAWA, Ryota KINJO,
Hideki TAKEBA, Chikara KONDO, Yuji OTAKE, Hitoshi TANAKA

RIKEN SPring-8 Center

Kenji FUKAMI

JASRI

For broad spectral tunability

- Beamlines of long wavelengths branch off from the middle of LINAC.

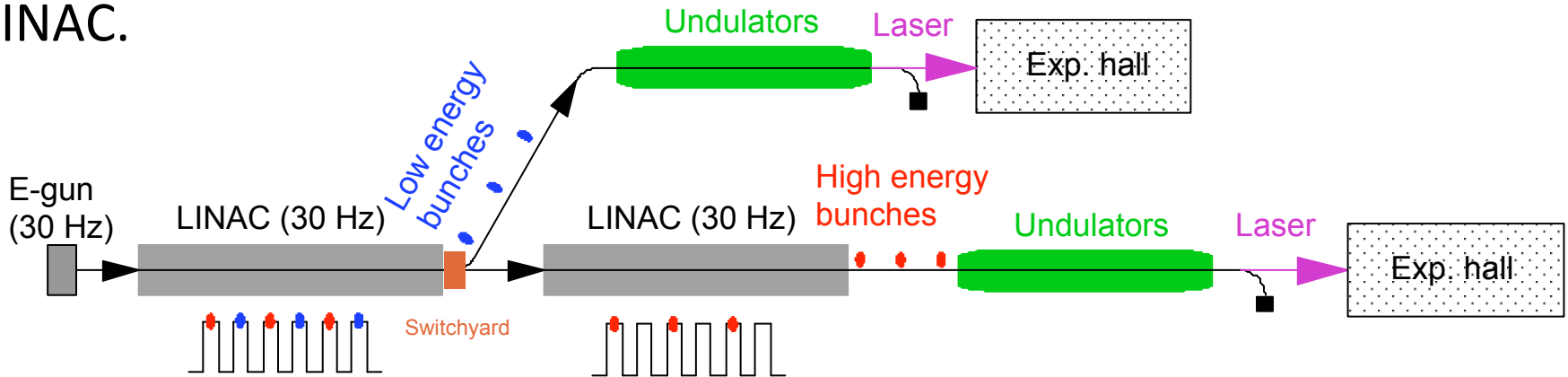

- Multi-energy operation of LINAC.

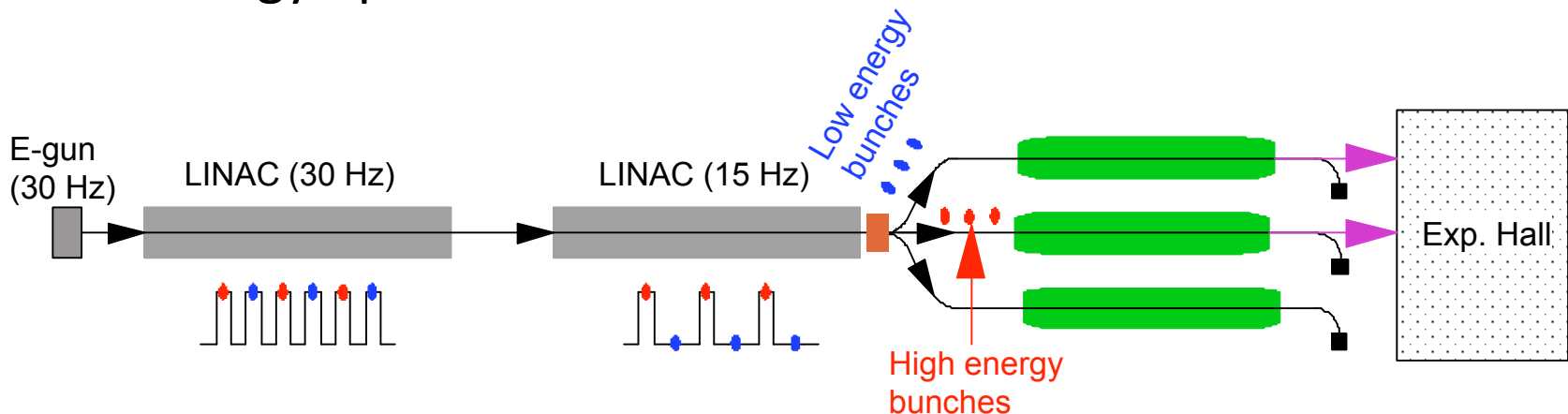

SACLA facility

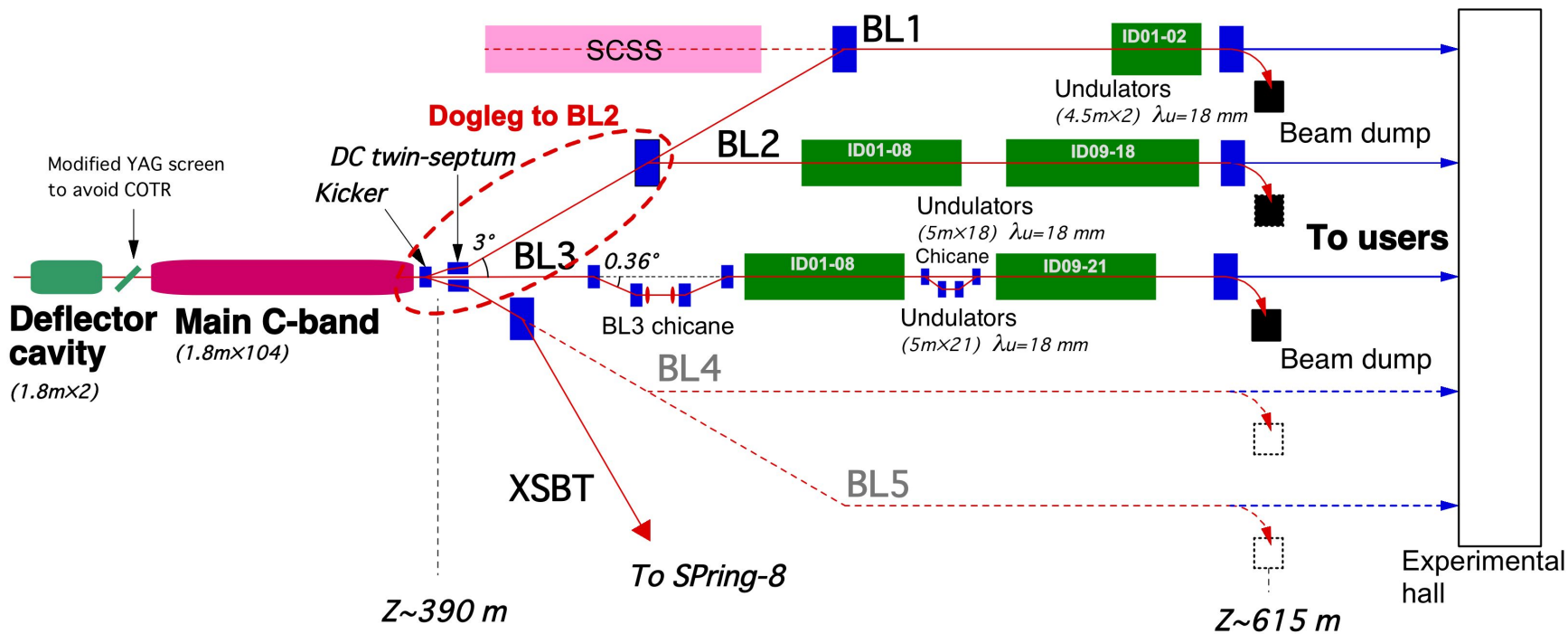
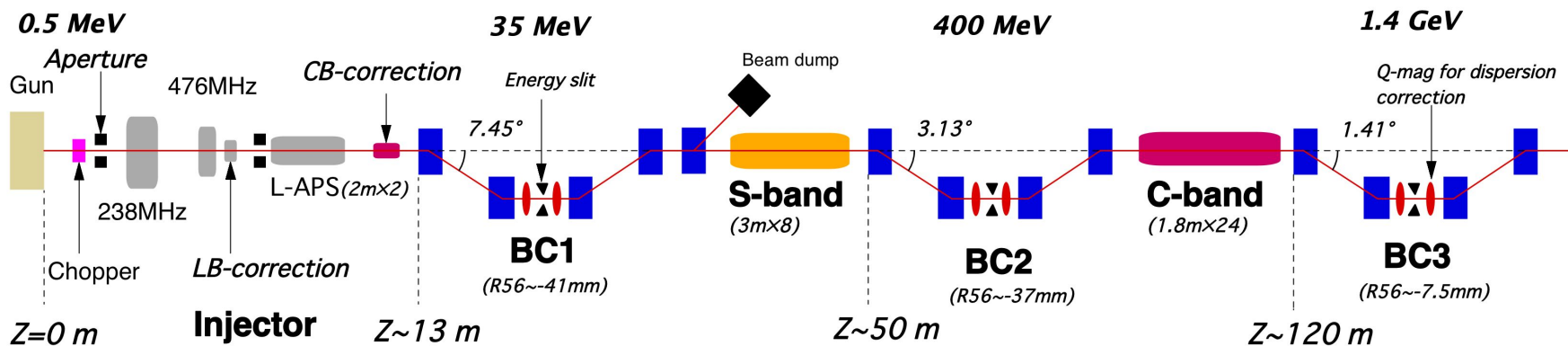

Beamline switchyard

- DC bending magnet was replaced by kicker and DC twin-septum magnets in January 2015.
- Small kick angle for the kicker to relax the stability requirement (target angle error is $0.1 \mu\text{rad}$ (p-p) corresponding to 1×10^{-5} (p-p) stability).

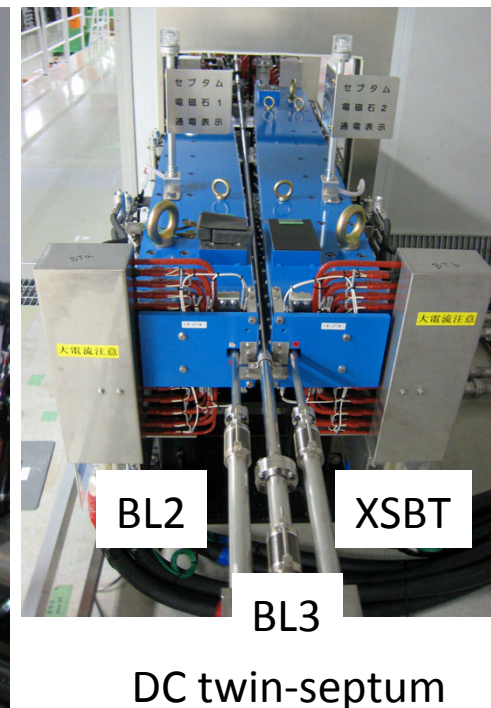

Example of a switching pattern

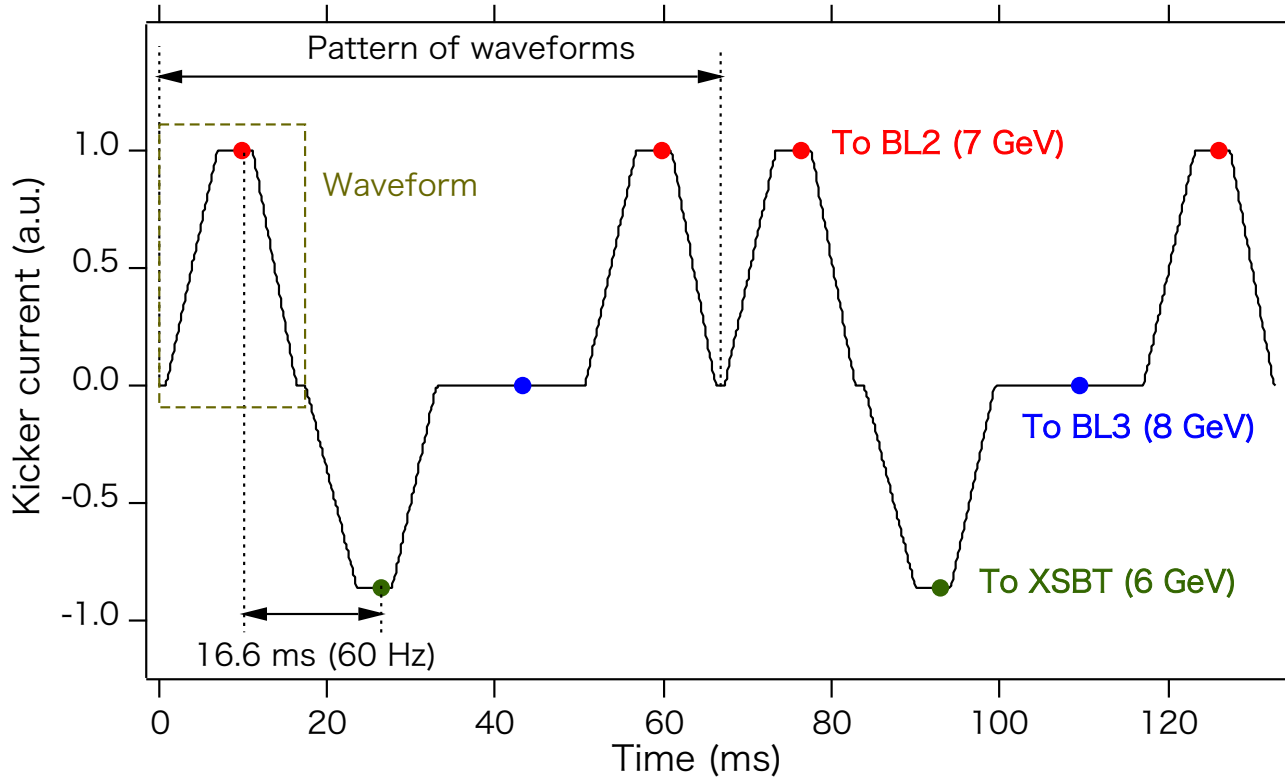

- The power supply of the kicker is a non-resonant type.
- The kicker is driven by trapezoidal waveforms with arbitrary polarity and amplitude.

Stability of kicker pulses

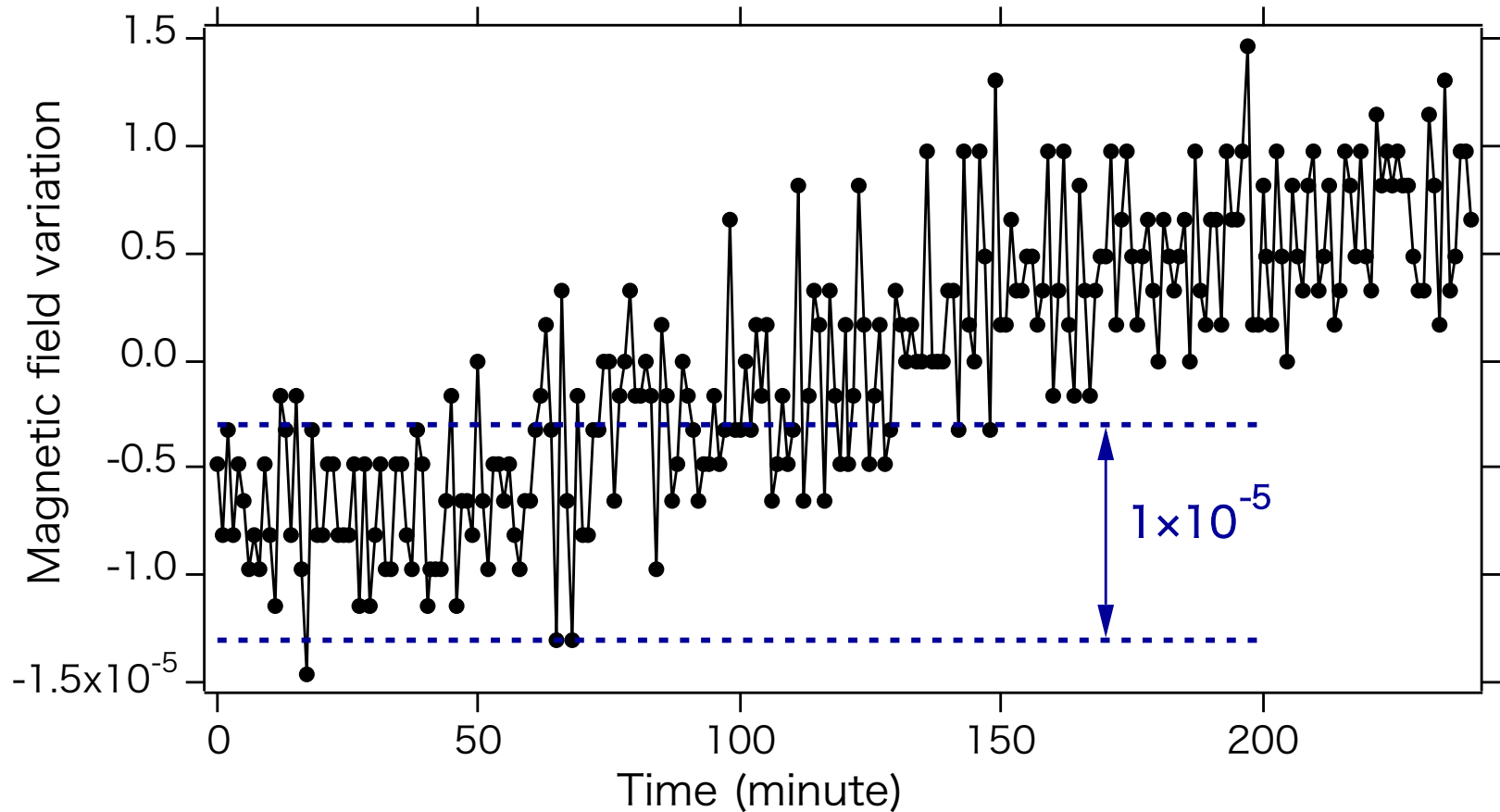

- Sampling interval 1 min, a full horizontal scale 4 hours.
- Slow drift is corrected by a beam orbit feedback.

BL2 dogleg

Since 3° is divided unequally between the kicker and septum, DBA lattice can not be applied to cancel CSR effects.

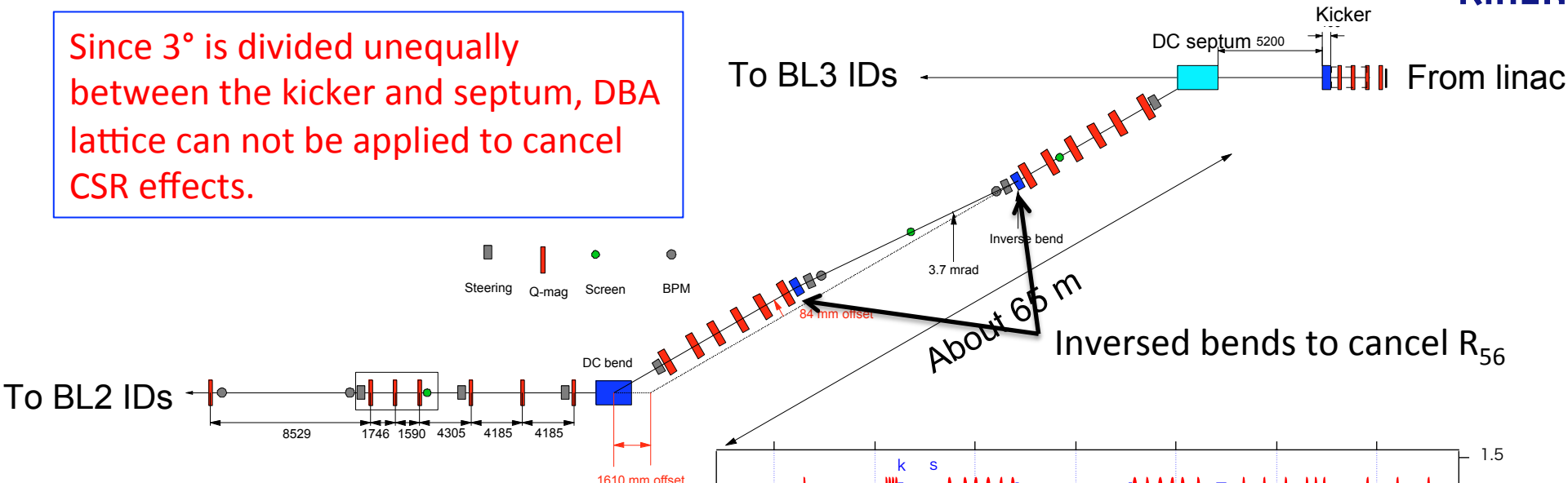

R_{56} of dogleg:
 DC switching magnet 1.6 mm,
 kicker + septum without correction 4.0 mm,
 kicker + septum with correction 0.07 ± 0.4 mm.

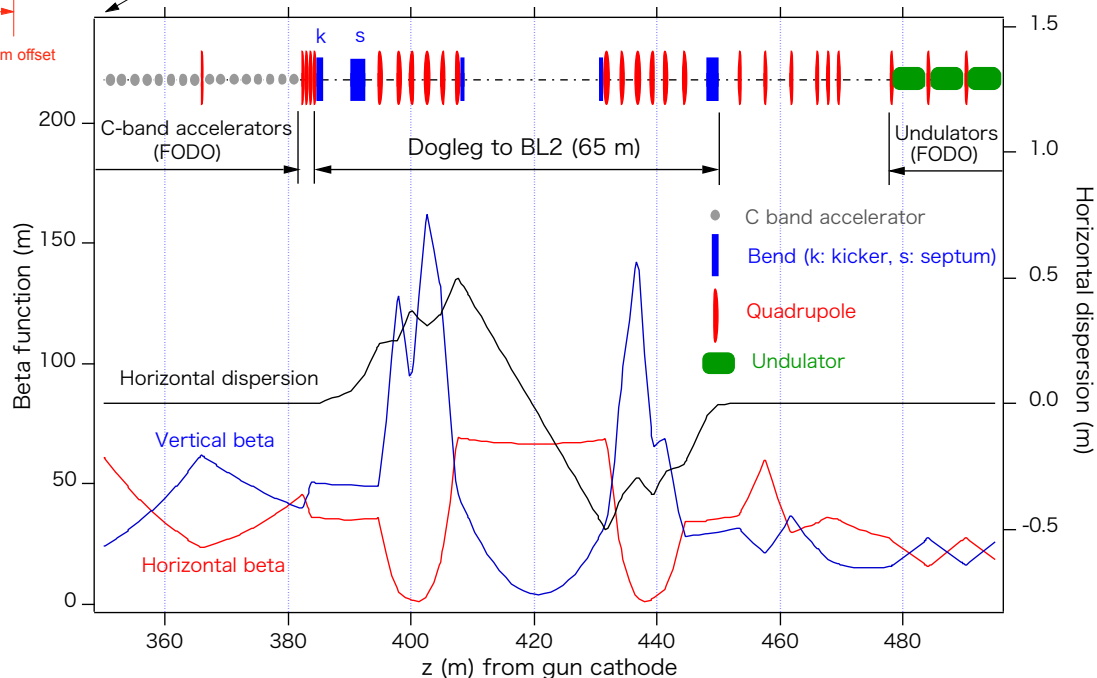

CSR effects at the BL2 dogleg

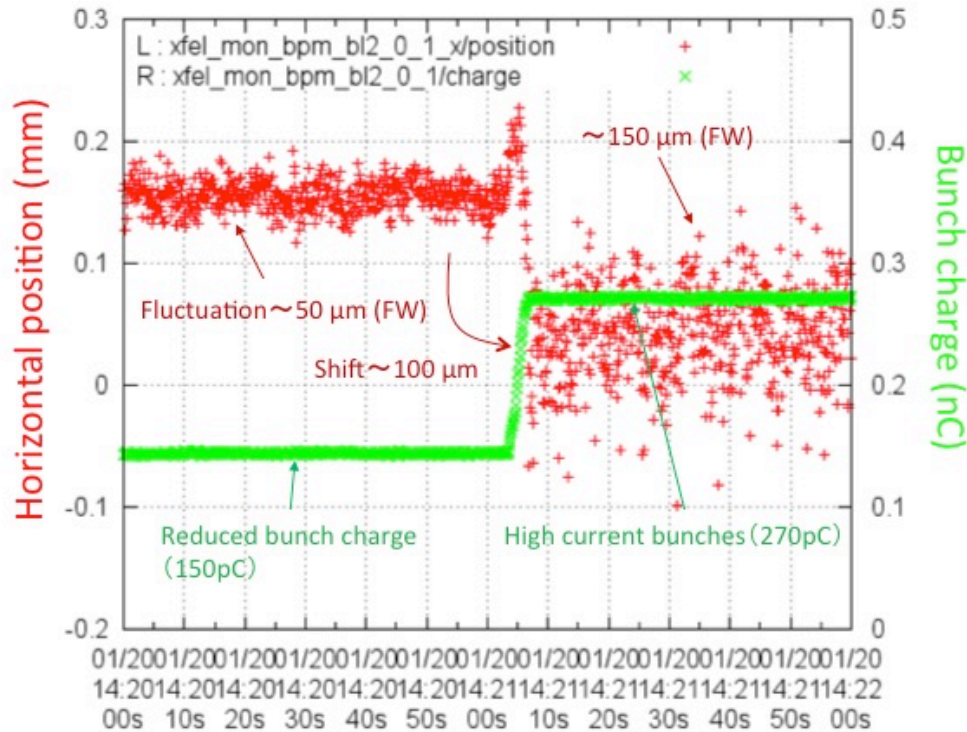

Horizontal orbit fluctuation after the dogleg.

- Lasing can be obtained for 10 kA bunches, but with large intensity fluctuation and small pulse energy around $30 \mu\text{J}$.
- Transverse beam profiles are horizontally diffused after the dogleg.
- Pulse energy maximized at 100-150 μJ with 1 kA bunches.

	Horizontal (pm-rad)	Vertical (pm-rad)
BL2 high current (10 kA)	16.3	0.74
BL2 low current (1 kA)	2.7	0.64
BL3 high current (10 kA)	1.4	0.27
BL3 low current (1 kA)	0.83	0.24

Emittance beam size is 33 pm-rad assuming 7.8 GeV and $0.5 \mu\text{m-rad}$ (norm. emit.).

Electron bunch profiles of SACLA

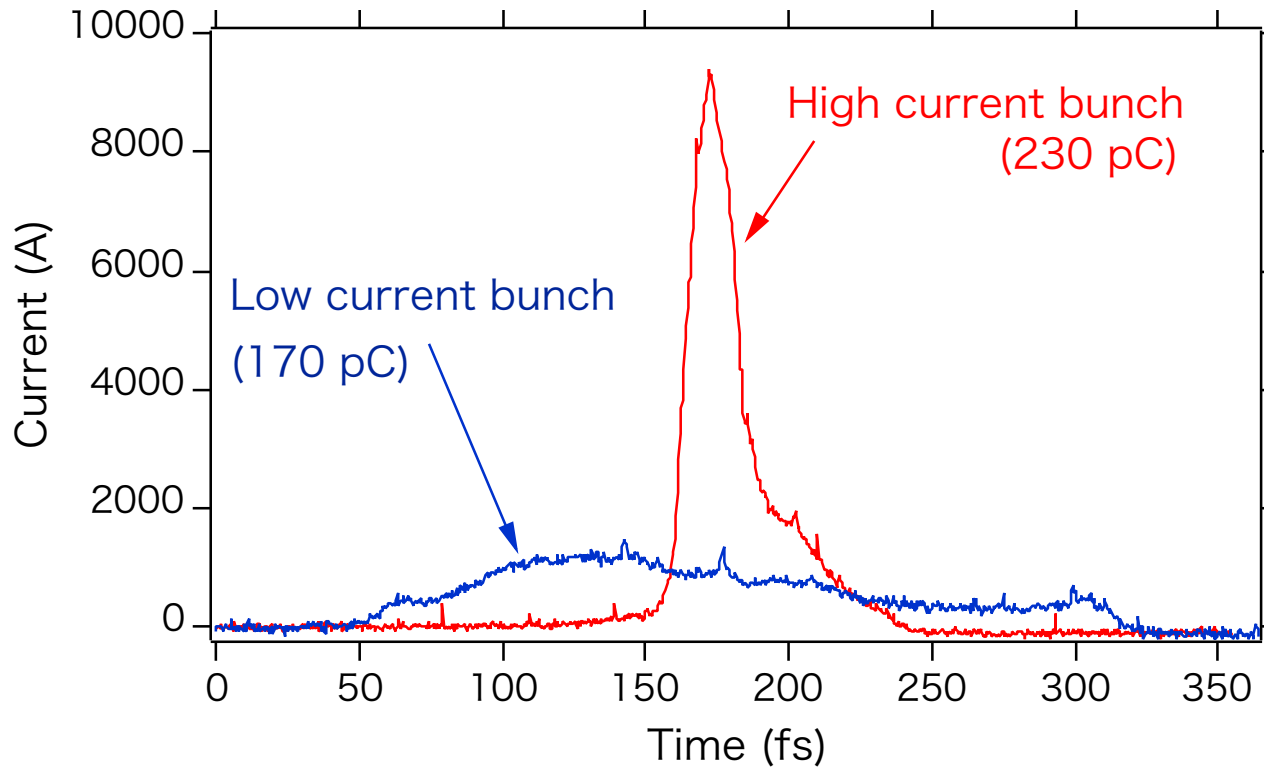

- Longitudinal electron bunch profiles measured by a C-band RF deflector including a beam size.
- High current bunch used for the normal operation of SACLA BL3, ~10 kA.
- Low current bunch obtained after the parameter optimization for BL2, ~1 kA.

Multi-beamline operation

Electron beam energy 7.8 GeV, peak current 1.2 kA, repetition 30 Hz

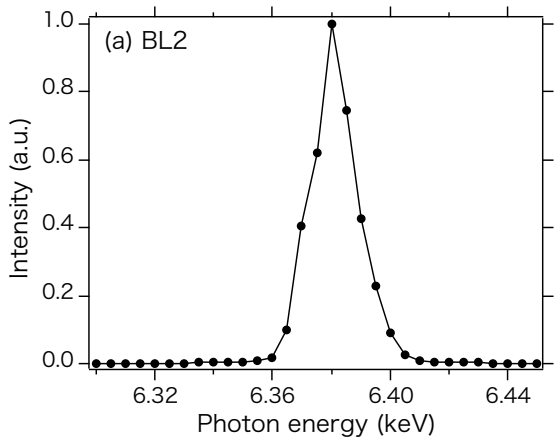

BL2
 7.8 GeV
 6.38 keV
 15 Hz
 K=2.85

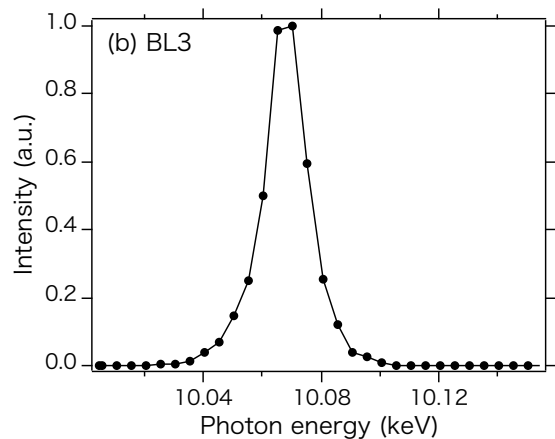
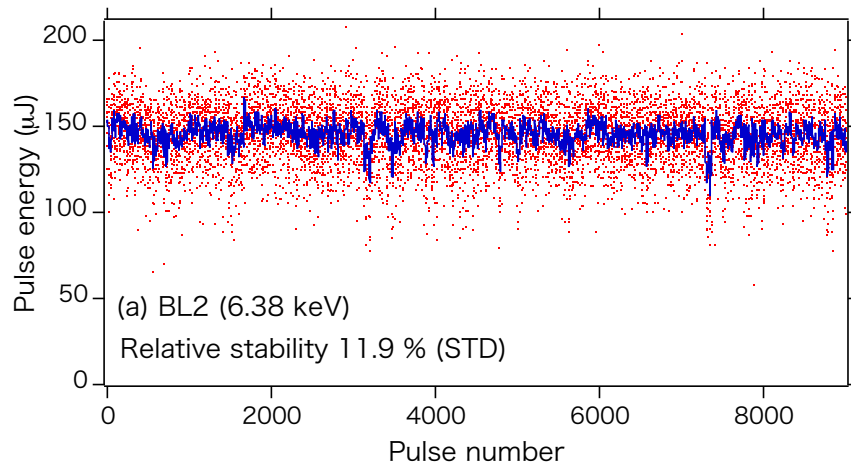

BL3
 7.8 GeV
 10.07 keV
 15 Hz
 K=2.1

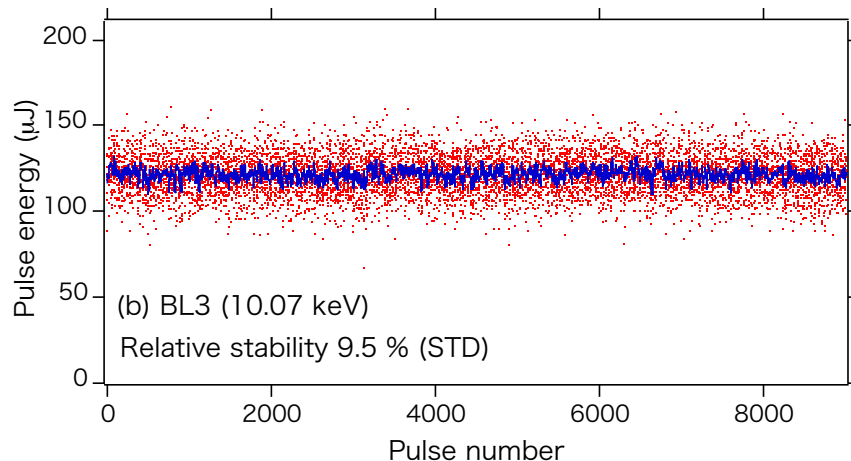

Full horizontal scale is 10 mins.

Multi-beamline operation

Electron beam energy 7.8 GeV, peak current 1.2 kA, repetition 30 Hz

BL2
7.8 GeV
6.38 keV
15 Hz
K=2.85

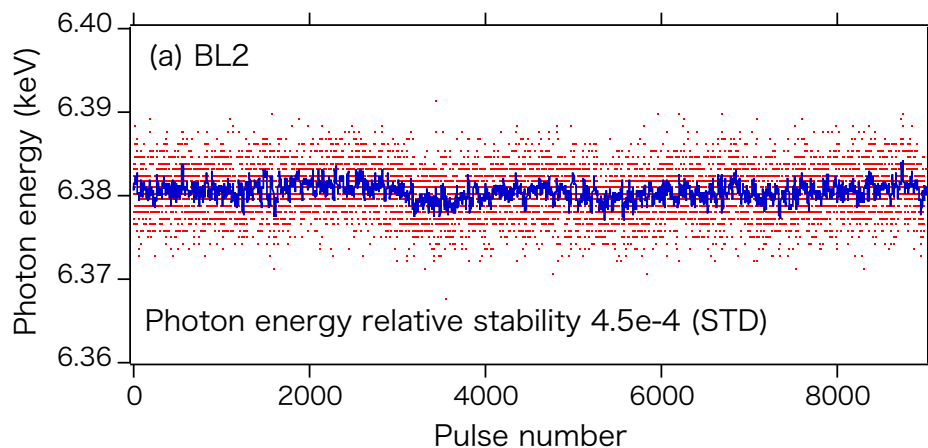

Full horizontal scale
is 10 mins.

BL3
7.8 GeV
10.07 keV
15 Hz
K=2.1

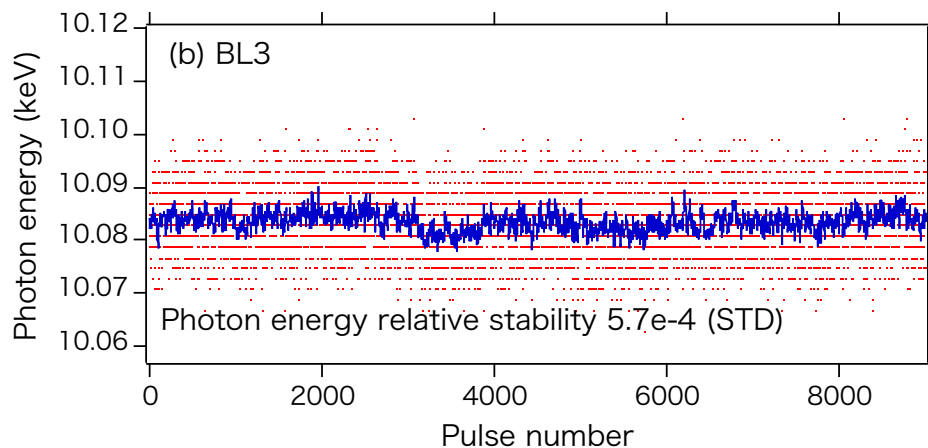

Stabilities of the central wavelengths are about 5×10^{-4} (STD).

Multi-energy acceleration for broad tunability

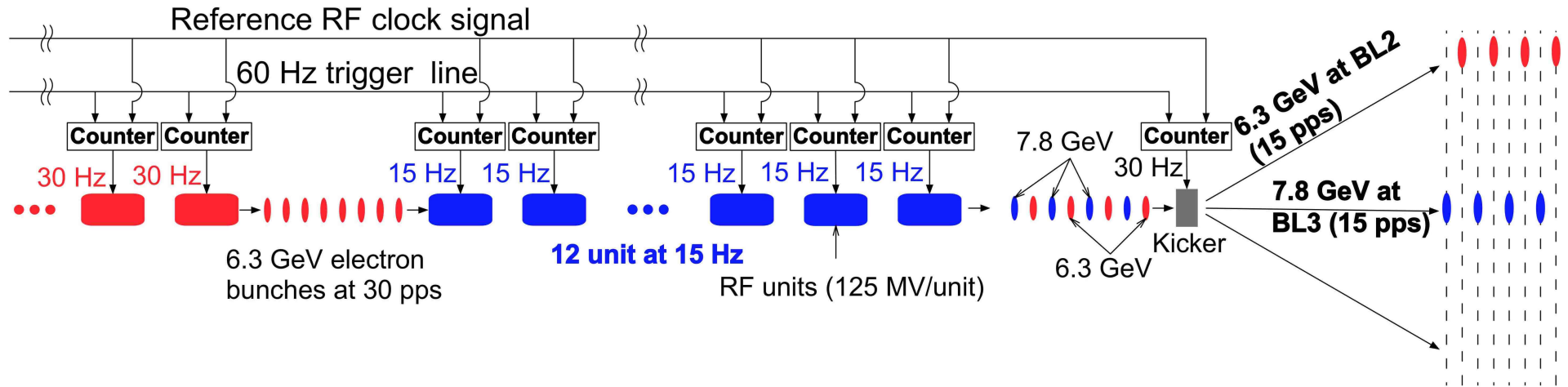

- There are 52 klystrons (104 accelerator structures) downstream of BC3 for crest acceleration. In the demonstration, 12 C-band klystrons are operated at 15 Hz to lower the beam energy for BL2.
- The beam energy of BL2 decreases from 7.8 GeV to 6.3 GeV. The spectral range is extended toward lower photon energies at BL2.

Multi-energy electron bunches

Peak current 1.2 kA, repetition 30 Hz

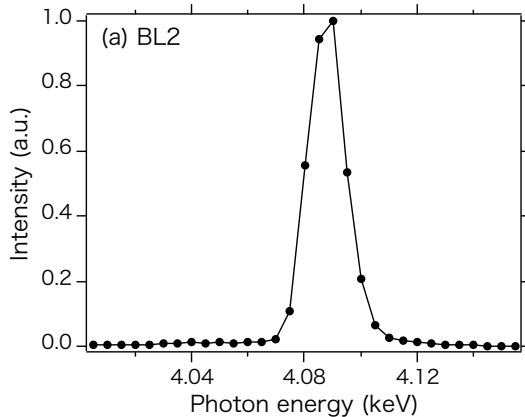

BL2
 6.3 GeV
 4.09 keV
 15 Hz
 K=2.85

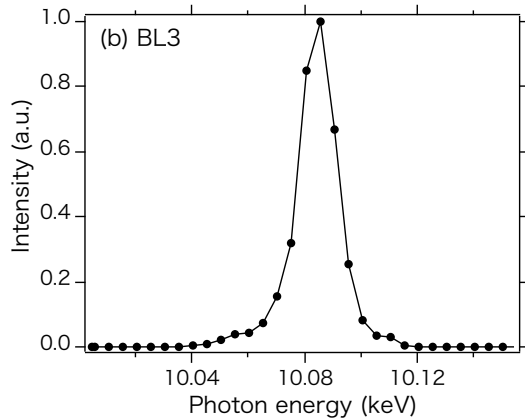

BL3
 7.8 GeV
 10.09 keV
 15 Hz
 K=2.1

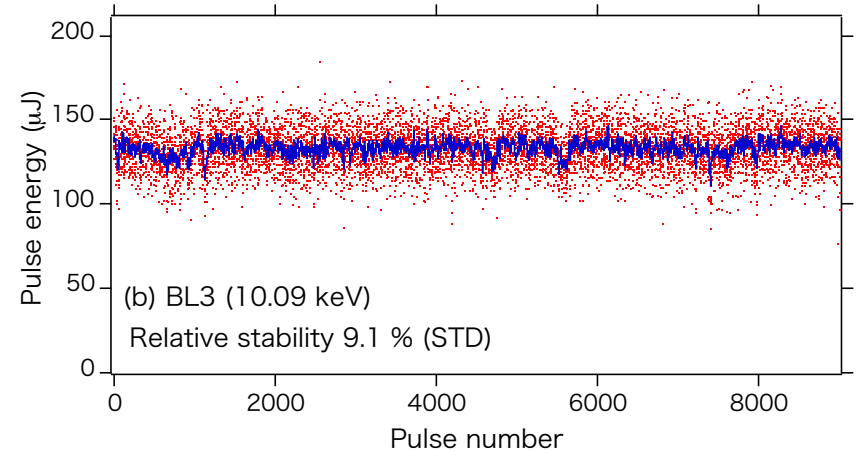
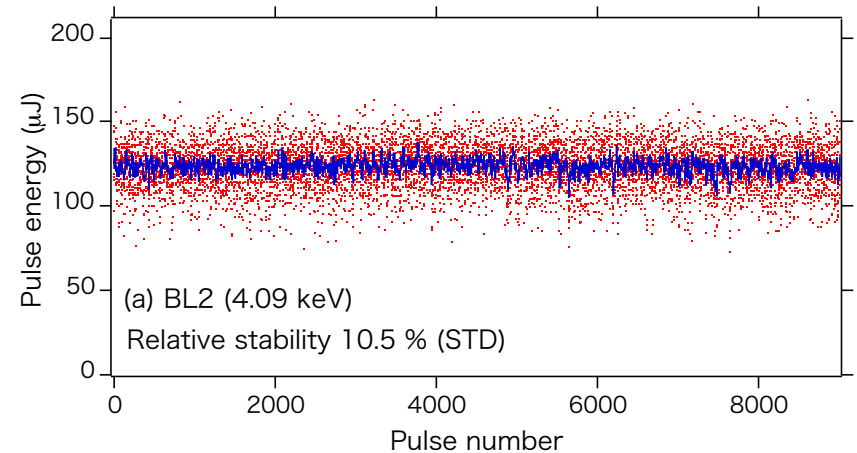

By reducing the beam energy of BL2 from 7.8 GeV to 6.3 GeV, the photon energy decreases from 6.38 keV to 4.09 keV at BL2.

Summary

- 30 Hz electron bunches are alternately deflected to two undulator beamlines, and stable lasing is successfully obtained at both beamlines.
- CSR effects at the dogleg currently limit the peak current to around 1 kA. Rearrangement of the beam optics is under consideration.
- Multi-energy operation of the linear accelerator has been demonstrated. It allows the optimization of the beam energies for the wavelengths of individual users in the multi-beamline operation.